

BLUE-MASTER®
by *celesa*



BROCAS
PARA METAL

BROCAS HELICOIDAIS COM CABO CILINDRICO DIN 338



- 10 U. Ø 0,20 - Ø 10,50 mm
- 6 U. Ø 10,60 - Ø 14 mm
- 1 U. Ø 14,10 - Ø 20 mm
- 1 U. BC9-BC99
BC7-BC98-BC42



		BTX	TTX	BC51	BC95	BC55	BC57	BC50	BC7	BC98	BC42
MATERIAL		HSSCo 5%	HSS	HSSCo 5%	HSSCo 5%	HSSCo 5%	HSSCo 5%	HSSCo 5%	PMD	PMD	MD
AFIAÇÃO											
ÂNGULO PONTA		135°	135°	135°	130°	135°	135°	118°	118°	135°	135°
HÉLICE		38° "5"	38° "5"	30° "N"	Ø ≥ 3	38° "5"	38° "5"	38° "N"	30° "N"	30° "N"	35° "N"
ACABAMENTO		DOURADO	TiAlSiN	TiAlN	DOURADO OX	BRILHANTE	TiAlN	TiAlN	BRILHANTE	BRILHANTE	BRILHANTE
APLICAÇÃO		120 Kg/mm²	80 Kg/mm²	ALTA PRODUÇÃO	INOX	INOX	INOX	INOX Plus	FUNDAÇÃO	70 HRc	ALTA PRODUÇÃO
Ø mm	L1 x L2	€	€	€	€	€	€	€	€	€	€
0,20	19 x 2,50										
0,25	19 x 3										
0,30	19 x 3										
0,35	19 x 4										
0,40	20 x 5										
0,45	20 x 5										
0,50	22 x 6										16,43
0,55	24 x 7										
0,60	24 x 7										
0,65	26 x 8										
0,70	28 x 9										
0,75	28 x 9										
0,80	30 x 10										
0,85	30 x 10										
0,90	32 x 11										
0,95	32 x 11										
1,00	34 x 12			3,58	3,22	4,26	6,08				10,34
1,05	34 x 12										
1,10	36 x 14										10,56
1,15	36 x 14										
1,19	3/64"										
1,20	38 x 16					5,63	5,83				10,97
1,25	38 x 16										
1,30	38 x 16										11,31
1,35	40 x 18										
1,40	40 x 18										11,38
1,45	40 x 18										
1,50	40 x 18			3,62	3,07	4,14	6,07				11,52
1,55	43 x 20										

Rosa Brocas Metal

Ø 0,20-1,5mm

BROCAS HELICOIDAIS COM CABO CILINDRICO DIN 338

Brocas Metal

Cinza

Rosso

**DIN
338**

		BC2	BC82	BC02	BC9	BC5	BC99	BC58	BC16	BC66	BC15	BC18
MATERIAL		HSS	HSS	HSS-G	HSS	HSSCo 5%	HSSCo 5%	HSSCo 8%	HSS	HSS	HSS	HSS
AFIAÇÃO												
ÂNGULO PONTA		118°	118°	118°	118°	135°	135°	135°	135°	118°	118°	118°
HÉLICE		30° "N"	30° "N"	30° "N"	30° "N"	30° "N"	30° "N"	30° "N"	40° "W"	15° "H"	30° "N"	30° "N"
ACABAMENTO		OX	BRILHANTE	DOURADO OX	OX	DOURADO	DOURADO	DOURADO	BRILHANTE	BRILHANTE	OX	TiN
APLICAÇÃO												
Ø mm	L1 x L2	€	€	€	€	€	€	€	€	€	€	€
1,59	1/16"	1,66				3,04						
1,60	43 x 20	1,81	1,81			3,27						2,49
1,65	43 x 20	1,81	1,81									
1,70	43 x 20	1,81	1,81			3,27						2,48
1,75	46 x 22	1,63	1,63			3,18		4,70	2,82	4,57		2,39
1,80	46 x 22	1,62	1,62			3,19						2,34
1,85	46 x 22	1,62	1,62									
1,90	46 x 22	1,62	1,62			3,19						2,34
1,95	48 x 24	1,62										
1,98	5/64"	1,47				2,98						
2,00	49 x 24	1,38	1,38	1,46		2,63		3,89	2,46	2,87	3,87	2,20
2,05	49 x 24	1,41	1,41									
2,10	49 x 24	1,41	1,41			3,10						2,18
2,15	53 x 27	1,41										
2,20	53 x 27	1,41	1,41			3,10						2,17
2,25	53 x 27	1,30	1,30	1,45		2,95		4,70	2,80	3,13		2,11
2,30	53 x 27	1,62	1,62			3,10						2,32
2,35	53 x 27	1,63	1,63									
2,38	3/32"	1,55				2,93						
2,40	57 x 30	1,62	1,62			3,10						2,32
2,45	57 x 30	1,62										
2,50	57 x 30	1,37	1,37	1,53		2,41		3,89	2,30	2,71	3,87	2,18
2,55	57 x 30	1,66	1,66									
2,60	57 x 30	1,66	1,66			2,98						2,33
2,65	57 x 30	1,66										
2,70	61 x 33	1,66	1,66	1,86		2,98						2,33
2,75	61 x 33	1,45	1,45	1,59		2,95		4,70	2,80	3,67		2,27
2,78	7/64"	1,59				2,85						
2,80	61 x 33	1,66	1,66	1,86		2,99						2,33

BROCAS HELICOIDAIS COM CABO CILINDRICO DIN 338



- 10 U.** Ø 0,20 - Ø 10,50 mm
- 6 U.** Ø 10,60 - Ø 14 mm
- 1 U.** Ø 14,10 - Ø 20 mm
- 1 U.** BC9-BC99
BC7-BC98-BC42



		BTX	TTX	BC51	BC95	BC55	BC57	BC50	BC7	BC98	BC42
MATERIAL		HSSCo 5%	HSS	HSSCo 5%	HSSCo 5%	HSSCo 5%	HSSCo 5%	HSSCo 5%	PMD	PMD	MD
AFIAÇÃO											
ÂNGULO PONTA		135°	135°	135°	130°	135°	135°	118°	118°	135°	135°
HÉLICE											
ACABAMENTO		DOURADO	TiAlSiN	TiAlN	DOURADO OX	BRILHANTE	TiAlN	TiAlN	BRILHANTE	BRILHANTE	BRILHANTE
APLICAÇÃO											
Ø mm	L1 x L2	€	€	€	€	€	€	€	€	€	€
1,59	1/16"										
1,60	43 x 20					4,70					11,90
1,65	43 x 20						3,99				
1,70	43 x 20										12,31
1,75	46 x 22				3,07						
1,80	46 x 22					4,19	5,97				12,37
1,85	46 x 22										
1,90	46 x 22					4,58					12,62
1,95	48 x 24										
1,98	5/64"										
2,00	49 x 24			3,77	3,07	4,11	6,09	5,17	20,75		14,28
2,05	49 x 24										
2,10	49 x 24					4,30			22,32		20,03
2,15	53 x 27										
2,20	53 x 27					4,35	6,45		22,32		21,54
2,25	53 x 27				3,07				22,32		
2,30	53 x 27					4,25			22,32		21,54
2,35	53 x 27										
2,38	3/32"										
2,40	57 x 30					4,36			22,32		21,92
2,45	57 x 30										
2,50	57 x 30			3,49	2,87	3,84	5,65	5,24	20,75		17,30
2,55	57 x 30										
2,60	57 x 30					4,68			22,32		27,05
2,65	57 x 30										
2,70	61 x 33					4,45			21,26		27,05
2,75	61 x 33			3,69	2,87				22,32		
2,78	7/64"										
2,80	61 x 33					4,82	9,23		22,32		27,05

Rosa

Brocas Metal

Ø 1,59-2,80mm

BROCAS HELICOIDAIS COM CABO CILINDRICO DIN 338

Brocas Metal

Cinza

Rosso

**DIN
338**

		BC2	BC82	BC02	BC9	BC5	BC99	BC58	BC16	BC66	BC15	BC18
MATERIAL		HSS	HSS	HSS-G	HSS	HSSCo 5%	HSSCo 5%	HSSCo 8%	HSS	HSS	HSS	HSS
AFIAÇÃO												
ÂNGULO PONTA		118°	118°	118°	118°	135°	135°	135°	135°	118°	118°	118°
HÉLICE												
ACABAMENTO		OX	BRILHANTE	DOURADO OX	OX	DOURADO	DOURADO	DOURADO	BRILHANTE	BRILHANTE	OX	TiN
APLICAÇÃO												
Ø mm	L1 x L2	€	€	€	€	€	€	€	€	€	€	€
2,85	61 x 33	1,68										
2,90	61 x 33	1,66	1,66			2,98						2,33
2,95	61 x 33	1,66										
3,00	61 x 33	1,25	1,25	1,37		2,36		3,76	2,27	3,01	3,36	2,06
3,05	65 x 36	1,61										
3,10	65 x 36	1,45	1,45	1,58		2,86		5,03				2,61
3,15	65 x 36	1,61										
3,17	1/8"	1,39				2,72						
3,20	65 x 36	1,45	1,45	1,58		2,86		5,03	2,80			2,61
3,25	65 x 36	1,45	1,45	1,58		2,86		4,62	2,80	3,67		2,61
3,30	65 x 36	1,45	1,45	1,58		2,86		5,03	2,80			2,61
3,35	65 x 36	1,86										
3,40	70 x 39	1,86	1,86	2,06		2,99						2,80
3,45	70 x 39	1,87										
3,50	70 x 39	1,41	1,41	1,58		2,85		4,53	2,74	3,21	4,00	2,58
3,55	70 x 39	1,94										
3,57	9/64"	1,82				3,42						
3,60	70 x 39	1,94	1,94	2,16		3,59						2,81
3,65	70 x 39	1,94										
3,70	70 x 39	1,94	1,94	2,16		3,59						2,82
3,75	70 x 39	1,62	1,62	1,86		3,38		5,49	3,27	4,78		2,72
3,80	75 x 43	1,99	1,99	2,27		3,59						2,86
3,85	75 x 43	1,99										
3,90	75 x 43	1,99	1,99	2,27		3,59						2,85
3,95	75 x 43	1,99										
3,97	5/32"	1,88				3,42						
4,00	75 x 43	1,58	1,58	1,78		3,04		4,91	2,95	3,49	4,37	2,69
4,05	75 x 43	1,99										
4,10	75 x 43	1,78	1,78	1,99		3,38		6,05	3,21			2,79

BROCAS HELICOIDAIS COM CABO CILINDRICO DIN 338



- 10 U. Ø 0,20 - Ø 10,50 mm
- 6 U. Ø 10,60 - Ø 14 mm
- 1 U. Ø 14,10 - Ø 20 mm
- 1 U. BC9-BC99
BC7-BC98-BC42



		BTX	TTX	BC51	BC95	BC55	BC57	BC50	BC7	BC98	BC42
MATERIAL		HSSCo 5%	HSS	HSSCo 5%	HSSCo 5%	HSSCo 5%	HSSCo 5%	HSSCo 5%	PMD	PMD	MD
AFIAÇÃO											
ÂNGULO PONTA		135°	135°	135°	130°	135°	135°	118°	118°	135°	135°
HÉLICE		38° "5"	38° "5"	30° "N"	Ø ≥ 3	38° "5"	38° "5"	38° "N"	30° "N"	30° "N"	35° "N"
ACABAMENTO		DOURADO	TiAlSiN	TiAlN	DOURADO OX	BRILHANTE	TiAlN	TiAlN	BRILHANTE	BRILHANTE	BRILHANTE
APLICAÇÃO		120 Kg/mm²	80 Kg/mm²	ALTA PRODUÇÃO	INOX	INOX	INOX	INOX Plus	FUNDAÇÃO	70 Hrc	ALTA PRODUÇÃO
Ø mm	L1 x L2	€	€	€	€	€	€	€	€	€	€
2,85	61 x 33										
2,90	61 x 33					4,86			22,32		27,05
2,95	61 x 33										
3,00	61 x 33	2,02	1,92	3,44	2,82	3,73	5,60	5,78	20,64	15,48	20,75
3,05	65 x 36										
3,10	65 x 36					4,50	6,88		21,13		27,30
3,15	65 x 36										
3,17	1/8"										
3,20	65 x 36	2,48	2,36		3,45	4,50	6,93		20,73		27,30
3,25	65 x 36				3,46				21,34		
3,30	65 x 36	2,48	2,36	4,36	3,46	4,50	6,89	7,01	20,94	17,52	24,00
3,35	65 x 36										
3,40	70 x 39					5,24			21,34		29,94
3,45	70 x 39										
3,50	70 x 39	2,47	2,35	4,32	3,40	4,54	6,84	6,20	20,24	16,17	23,67
3,55	70 x 39										
3,57	9/64"										
3,60	70 x 39					5,24			21,13	17,52	31,37
3,65	70 x 39										
3,70	70 x 39					5,24			21,73		31,37
3,75	70 x 39				3,70				21,73		
3,80	75 x 43					5,98	9,94		21,73		32,90
3,85	75 x 43										
3,90	75 x 43					5,72			21,73		32,90
3,95	75 x 43										
3,97	5/32"										
4,00	75 x 43	2,49	2,37	4,46	3,70	4,88	7,21	7,03	20,63	15,74	26,63
4,05	75 x 43										
4,10	75 x 43					5,40	7,77		20,87		34,21

BROCAS HELICOIDAIS COM CABO CILINDRICO DIN 338

Brocas Metal

Cinza

Rosso

**DIN
338**

		BC2	BC82	BC02	BC9	BC5	BC99	BC58	BC16	BC66	BC15	BC18
MATERIAL		HSS	HSS	HSS-G	HSS	HSSCo 5%	HSSCo 5%	HSSCo 8%	HSS	HSS	HSS	HSS
AFIAÇÃO												
ÂNGULO PONTA		118°	118°	118°	118°	135°	135°	135°	135°	118°	118°	118°
HÉLICE		30° "N"	30° "N"	30° "N"	30° "N"	30° "N"	30° "N"	30° "N"	40° "W"	15° "H"	30° "N"	30° "N"
ACABAMENTO		OX	BRILHANTE	DOURADO OX	OX	DOURADO	DOURADO	DOURADO	BRILHANTE	BRILHANTE	OX	TiN
APLICAÇÃO												
Ø mm	L1 x L2	€	€	€	€	€	€	€	€	€	€	€
4,15	75 x 43	1,99										
4,20	75 x 43	1,78	1,78	1,99		3,38		6,05	3,21			2,79
4,25	75 x 43	1,78	1,78	1,99		3,38		5,49	3,74	5,18		2,79
4,30	80 x 47	2,36	2,36	2,68		3,59						3,10
4,35	80 x 47	2,34										
4,37	11/64"	2,21				3,42						
4,40	80 x 47	2,36	2,36	2,68		3,59						3,10
4,45	80 x 47	2,36										
4,50	80 x 47	1,86	1,86	2,02		3,48		5,49	3,30	4,26	4,53	2,82
4,55	80 x 47	2,38										
4,60	80 x 47	2,38	2,38			4,00						3,11
4,65	80 x 47	2,38										
4,70	80 x 47	2,38	2,38	2,68		4,00						3,11
4,75	80 x 47	2,11	2,11	2,39		3,80		6,06	4,21	6,27		3,00
4,76	3/16"	2,02				3,55						
4,80	86 x 52	2,68	2,68	2,93		4,03		6,68				3,30
4,85	86 x 52	2,59										
4,90	86 x 52	2,59	2,59	2,86		4,03						3,25
4,95	86 x 52	2,61										
5,00	86 x 52	1,98	1,98	2,20		3,65		5,88	3,53	4,62	4,92	2,88
5,05	86 x 52	2,69	2,69									
5,10	86 x 52	2,68	2,68	2,96		4,37		7,20	4,08		6,83	3,29
5,15	86 x 52	2,69										
5,16	13/64"	2,56				3,76						
5,20	86 x 52	2,68	2,68	2,96		4,37		7,20				3,30
5,25	86 x 52	2,50	2,50	2,84		4,31		6,90	5,03	7,02		3,28
5,30	86 x 52	3,33	3,33	3,68		4,37						3,73
5,35	93 x 57	3,32										
5,40	93 x 57	3,33	3,33			4,37						3,73

BROCAS HELICOIDAIS COM CABO CILINDRICO DIN 338



- 10 U. Ø 0,20 - Ø 10,50 mm
- 6 U. Ø 10,60 - Ø 14 mm
- 1 U. Ø 14,10 - Ø 20 mm
- 1 U. BC9-BC99
BC7-BC98-BC42



		BTX	TTX	BC51	BC95	BC55	BC57	BC50	BC7	BC98	BC42
MATERIAL		HSSCo 5%	HSS	HSSCo 5%	HSSCo 5%	HSSCo 5%	HSSCo 5%	HSSCo 5%	PMD	PMD	MD
AFIAÇÃO											
ÂNGULO PONTA		135°	135°	135°	130°	135°	135°	118°	118°	135°	135°
HÉLICE		38° "S"	38° "S"	30° "N"	Ø ≥ 3	38° "S"	38° "S"	38° "N"	30° "N"	30° "N"	35° "N"
ACABAMENTO		DOURADO	TiAlSiN	TiAlN	DOURADO OX	BRILHANTE	TiAlN	TiAlN	BRILHANTE	BRILHANTE	BRILHANTE
APLICAÇÃO		120 Kg/mm²	80 Kg/mm²	ALTA PRODUÇÃO	INOX	INOX	INOX	INOX Plus	FUNDAÇÃO	70 HRc	ALTA PRODUÇÃO
Ø mm	L1 x L2	€	€	€	€	€	€	€	€	€	€
4,15	75 x 43										
4,20	75 x 43	2,98	2,82	4,69	4,12	5,37	7,75	8,66	20,87	18,33	32,58
4,25	75 x 43			4,69					22,73		
4,30	80 x 47					5,73			22,73	18,33	40,72
4,35	80 x 47										
4,37	11/64"										
4,40	80 x 47					5,73			22,73	18,33	41,53
4,45	80 x 47										
4,50	80 x 47	3,05	2,89	4,73	4,12	5,56	7,92	8,12	20,48	15,13	32,56
4,55	80 x 47										
4,60	80 x 47					6,92			21,90		40,50
4,65	80 x 47										
4,70	80 x 47					6,43			21,28		40,50
4,75	80 x 47				4,27				22,73		
4,76	3/16"										
4,80	86 x 52					6,43	8,79		21,90		41,54
4,85	86 x 52										
4,90	86 x 52					7,09			22,73		41,54
4,95	86 x 52										
5,00	86 x 52	4,11	3,91	4,84	4,40	5,80	8,14	8,55	21,01	14,82	36,11
5,05	86 x 52										
5,10	86 x 52					6,93	9,23		22,46	18,14	47,10
5,15	86 x 52										
5,16	13/64"										
5,20	86 x 52					6,89	9,30		22,36		47,10
5,25	86 x 52				5,58				23,90		
5,30	86 x 52					6,93			23,90		47,10
5,35	93 x 57										
5,40	93 x 57					8,97			23,90		53,32

Rosa

Brocas Metal

Ø 4,15-5,40mm

BROCAS HELICOIDAIS COM CABO CILINDRICO DIN 338

Brocas Metal

Cinza

Rosso

**DIN
338**

		BC2	BC82	BC02	BC9	BC5	BC99	BC58	BC16	BC66	BC15	BC18
MATERIAL		HSS	HSS	HSS-G	HSS	HSSCo 5%	HSSCo 5%	HSSCo 8%	HSS	HSS	HSS	HSS
AFIAÇÃO												
ÂNGULO PONTA		118°	118°	118°	118°	135°	135°	135°	135°	118°	118°	118°
HÉLICE		30° "N"	30° "N"	30° "N"	30° "N"	30° "N"	30° "N"	30° "N"	40° "W"	15° "H"	30° "N"	30° "N"
ACABAMENTO		OX	BRILHANTE	DOURADO OX	OX	DOURADO	DOURADO	DOURADO	BRILHANTE	BRILHANTE	OX	TiN
APLICAÇÃO												
Ø mm	L1 x L2	€	€	€	€	€	€	€	€	€	€	€
5,45	93 x 57	3,33										
5,50	93 x 57	2,61	2,61	2,93		4,62		7,43	4,47	5,65	6,50	3,33
5,55	93 x 57	3,52										
5,56	7/32"	3,35				5,22						
5,60	93 x 57	3,53	3,53	3,91		5,49		9,16				3,88
5,65	93 x 57	3,52										
5,70	93 x 57	3,53	3,53	3,91		5,49		9,16				3,88
5,75	93 x 57	3,41	3,41	3,81		5,21		8,30	6,17	8,59		3,84
5,80	93 x 57	3,32	3,32	3,74		5,49		9,16				3,73
5,85	93 x 57	3,33										
5,90	93 x 57	3,32	3,32	3,74		5,49						3,73
5,95	15/64"	3,14				5,71						
6,00	93 x 57	2,72	2,72	3,02		4,97		7,90	4,73	6,08	6,73	3,38
6,05	101 x 63	3,86										
6,10	101 x 63	3,86	3,86	4,36		6,16						6,80
6,15	101 x 63	3,86										
6,20	101 x 63	3,86	3,86	4,36		6,16						6,80
6,25	101 x 63	3,65	3,65	4,08		5,81		9,25	6,17	8,59		6,80
6,30	101 x 63	4,07	4,07			6,16						6,89
6,35	1/4"	2,90				5,85						
6,40	101 x 63	4,19	4,19			6,17						6,99
6,45	101 x 63	4,09										
6,50	101 x 63	3,15	3,15	3,56		5,95		9,22	5,51	6,77	7,82	6,48
6,55	101 x 63	5,09										
6,60	101 x 63	5,06	5,06			7,40						7,54
6,65	101 x 63	5,09										
6,70	101 x 63	5,08	5,08	5,67		7,40		11,81				7,54
6,75	109 x 69	3,82	3,82	4,31		6,94		10,78	7,43	10,36		6,93
6,80	109 x 69	3,82	3,82	4,31		6,94		11,81	6,48			6,94

BROCAS HELICOIDAIS COM CABO CILINDRICO DIN 338



10 U. Ø 0,20 - Ø 10,50 mm

6 U. Ø 10,60 - Ø 14 mm

3 U. Ø 14,10 - Ø 20 mm

BC9-BC99
BC7-BC98-BC42



	BTX	TTX	BC51	BC95	BC55	BC57	BC50	BC7	BC98	BC42	
MATERIAL	HSSCo 5%	HSS	HSSCo 5%	HSSCo 5%	HSSCo 5%	HSSCo 5%	HSSCo 5%	PMD	PMD	MD	
AFIAÇÃO											
ÂNGULO PONTA	135°	135°	135°	130°	135°	135°	118°	118°	135°	135°	
HÉLICE	38° "5"	38° "5"	30° "N"	Ø ≥ 3	38° "5"	38° "5"	38° "N"	30° "N"	30° "N"	35° "N"	
ACABAMENTO	DOURADO	TiAlSiN	TiAlN	DOURADO OX	BRILHANTE	TiAlN	TiAlN	BRILHANTE	BRILHANTE	BRILHANTE	
APLICAÇÃO	120 Kg/mm²	80 Kg/mm²	ALTA PRODUÇÃO	INOX	INOX	INOX	INOX Plus	FUNDAÇÃO	70 Hrc	ALTA PRODUÇÃO	
Ø mm	L1 x L2	€	€	€	€	€	€	€	€	€	
5,45	93 x 57										
5,50	93 x 57	5,21	4,94	5,47	5,58	7,36	10,44	22,01	15,80	42,15	
5,55	93 x 57										
5,56	7/32"										
5,60	93 x 57					8,79		23,39		56,01	
5,65	93 x 57										
5,70	93 x 57					10,10		23,37		56,01	
5,75	93 x 57			5,93	8,31			24,99			
5,80	93 x 57				8,79	11,14		23,37		56,01	
5,85	93 x 57										
5,90	93 x 57				8,79			24,99		56,01	
5,95	15/64"										
6,00	93 x 57	5,54	5,26	5,67	5,93	7,89	10,23	11,59	22,79	16,84	47,82
6,05	101 x 63										
6,10	101 x 63				6,25	10,96		26,97		69,37	
6,15	101 x 63										
6,20	101 x 63					9,74	16,06	26,97		69,37	
6,25	101 x 63				6,75			26,97		69,37	
6,30	101 x 63					10,96		26,97		69,37	
6,35	1/4"										
6,40	101 x 63					10,96		26,97		69,37	
6,45	101 x 63										
6,50	101 x 63	6,47	6,15	10,55	6,93	9,45	15,77	13,80	25,46	17,16	59,38
6,55	101 x 63										
6,60	101 x 63					12,40		27,81		86,24	
6,65	101 x 63										
6,70	101 x 63					12,40		27,81		86,24	
6,75	109 x 69			11,06	8,06			27,81			
6,80	109 x 69	7,54	7,15	11,06	8,06	11,00	17,35	27,81	20,54	69,62	

Brocas Metal

Rosa

Ø 5,45-6,80mm

BROCAS HELICOIDAIS COM CABO CILINDRICO DIN 338

Brocas Metal

Cinza

Rosso

**DIN
338**

		BC2	BC82	BC02	BC9	BC5	BC99	BC58	BC16	BC66	BC15	BC18
MATERIAL		HSS	HSS	HSS-G	HSS	HSSCo 5%	HSSCo 5%	HSSCo 8%	HSS	HSS	HSS	HSS
AFIAÇÃO												
ÂNGULO PONTA		118°	118°	118°	118°	135°	135°	135°	135°	118°	118°	118°
HÉLICE		30° "N"	30° "N"	30° "N"	30° "N"	30° "N"	30° "N"	30° "N"	40° "W"	15° "H"	30° "N"	30° "N"
ACABAMENTO		OX	BRILHANTE	DOURADO OX	OX	DOURADO	DOURADO	DOURADO	BRILHANTE	BRILHANTE	OX	TiN
APLICAÇÃO				Plus					Al	LATÃO		PRODUÇÃO
Ø mm	L1 x L2	€	€	€	€	€	€	€	€	€	€	€
6,85	109 x 69	5,64										
6,90	109 x 69	5,65	5,65			7,40						7,86
6,95	109 x 69	5,65										
7,00	109 x 69	3,82	3,82	4,31		6,52		9,65	6,03	7,19	9,55	6,94
7,05	109 x 69	5,94										
7,10	109 x 69	5,93	5,93			9,42						8,14
7,14	9/32"	5,68				8,89						
7,15	109 x 69	5,95										
7,20	109 x 69	5,93	5,93			9,42				10,02		8,14
7,25	109 x 69	4,89	4,89	5,44		8,84		13,12	9,83	13,58		7,60
7,30	109 x 69	5,94	5,94			9,45						8,14
7,35	109 x 69	5,93										
7,40	109 x 69	5,94	5,94	6,65		9,45						8,14
7,45	109 x 69	6,09										
7,50	109 x 69	4,07	4,07	4,54		6,95		10,30	6,45	8,40	10,02	7,10
7,54	19/64"	6,63				10,76						
7,55	117 x 75	7,05										
7,60	117 x 75	6,99	6,99			11,36						8,94
7,65	117 x 75	7,05										
7,70	117 x 75	6,99	6,99			11,33						8,94
7,75	117 x 75	5,40	5,40	6,04		10,70		15,90	12,49	18,12		8,04
7,80	117 x 75	7,10	7,10	7,98		11,33						8,96
7,85	117 x 75	7,11										
7,90	117 x 75	7,10	7,10	7,98		11,39						8,96
7,94	5/16"	6,08				10,74						
7,95	117 x 75	7,10										
8,00	117 x 75	4,64	4,64	5,21		8,16		12,50	7,51	8,93	11,47	7,43
8,05	117 x 75	7,25										
8,10	117 x 75	7,25	7,25			10,86						9,81

BROCAS HELICOIDAIS COM CABO CILINDRICO DIN 338



- 10 U. Ø 0,20 - Ø 10,50 mm
- 6 U. Ø 10,60 - Ø 14 mm
- 1 U. Ø 14,10 - Ø 20 mm
- 1 U. BC9-BC99
BC7-BC98-BC42



		BTX	TTX	BC51	BC95	BC55	BC57	BC50	BC7	BC98	BC42
MATERIAL		HSSCo 5%	HSS	HSSCo 5%	HSSCo 5%	HSSCo 5%	HSSCo 5%	HSSCo 5%	PMD	PMD	MD
AFIAÇÃO											
ÂNGULO PONTA		135°	135°	135°	130°	135°	135°	118°	118°	135°	135°
HÉLICE		38° "5"	38° "5"	30° "N"	Ø ≥ 3	38° "5"	38° "5"	38° "N"	30° "N"	30° "N"	35° "N"
ACABAMENTO		DOURADO	TiAlSiN	TiAlN	DOURADO OX	BRILHANTE	TiAlN	TiAlN	BRILHANTE	BRILHANTE	BRILHANTE
APLICAÇÃO		120 Kg/mm²	80 Kg/mm²	ALTA PRODUÇÃO	INOX	INOX	INOX	INOX Plus	FUNDAÇÃO	70 Hrc	ALTA PRODUÇÃO
Ø mm	L1 x L2	€	€	€	€	€	€	€	€	€	€
6,85	109 x 69					12,52			27,81	20,54	86,24
6,90	109 x 69										
6,95	109 x 69										
7,00	109 x 69	7,08	6,73	11,13	7,58	10,25	16,85	16,22	27,74	19,21	69,15
7,05	109 x 69										
7,10	109 x 69					15,16			29,16	22,13	98,64
7,14	9/32"										
7,15	109 x 69										
7,20	109 x 69					14,52	20,95		29,16		98,64
7,25	109 x 69				8,04				29,16		
7,30	109 x 69					15,45			29,16		98,64
7,35	109 x 69										
7,40	109 x 69					15,45			29,16		98,64
7,45	109 x 69										
7,50	109 x 69	7,52	7,14	11,44	8,04	10,96	17,57	18,67	28,64	20,18	73,86
7,54	19/64"										
7,55	117 x 75										
7,60	117 x 75					15,89			31,32		98,64
7,65	117 x 75										
7,70	117 x 75					17,69			31,32		98,64
7,75	117 x 75				8,81				31,32		
7,80	117 x 75					17,69	24,92		31,32		98,64
7,85	117 x 75										
7,90	117 x 75					17,69			31,32		98,64
7,94	5/16"										
7,95	117 x 75										
8,00	117 x 75	8,81	8,36	12,12	9,43	12,85	19,39	19,73	29,17	22,55	84,35
8,05	117 x 75										
8,10	117 x 75					18,63			33,46		114,74

Rosa

Brocas Metal

Ø 6,85-8,10mm

BROCAS HELICOIDAIS COM CABO CILINDRICO DIN 338



- 10 U. Ø 0,20 - Ø 10,50 mm
- 6 U. Ø 10,60 - Ø 14 mm
- 1 U. Ø 14,10 - Ø 20 mm
- 1 U. BC9-BC99
BC7-BC98-BC42



		BTX	TTX	BC51	BC95	BC55	BC57	BC50	BC7	BC98	BC42
MATERIAL		HSSCo 5%	HSS	HSSCo 5%	HSSCo 5%	HSSCo 5%	HSSCo 5%	HSSCo 5%	PMD	PMD	MD
AFIAÇÃO											
ÂNGULO PONTA		135°	135°	135°	130°	135°	135°	118°	118°	135°	135°
HÉLICE		38° "5"	38° "5"	30° "N"	Ø ≥ 3	38° "5"	38° "5"	38° "N"	30° "N"	30° "N"	35° "N"
ACABAMENTO		DOURADO	TiAlSiN	TiAlN	DOURADO OX	BRILHANTE	TiAlN	TiAlN	BRILHANTE	BRILHANTE	BRILHANTE
APLICAÇÃO		120 Kg/mm²	80 Kg/mm²	ALTA PRODUÇÃO	INOX	INOX	INOX	INOX Plus	FUNDAÇÃO	70 HRc	ALTA PRODUÇÃO
Ø mm	L1 x L2	€	€	€	€	€	€	€	€	€	€
8,15	117 x 75										
8,20	117 x 75					17,37	25,07		33,46		114,74
8,25	117 x 75				9,63				33,46		
8,30	117 x 75					18,46			33,46		114,74
8,33	21/64"										
8,35	117 x 75										
8,40	117 x 75					18,46			33,46		114,74
8,45	117 x 75										
8,50	117 x 75	9,19	8,72	13,58	9,83	13,32	21,07	24,17	31,98	22,55	99,76
8,55	125 x 81										
8,60	125 x 81					18,81			35,93	27,27	133,01
8,65	125 x 81										
8,70	125 x 81					21,89			35,93		133,01
8,73	11/32"										
8,75	125 x 81				11,70				35,93		
8,80	125 x 81					21,40	29,02		35,93		133,01
8,85	125 x 81										
8,90	125 x 81					21,89			35,93		133,01
8,95	125 x 81										
9,00	125 x 81	11,70	11,12	15,03	12,54	17,00	24,78	25,67	31,92	24,45	110,28
9,05	125 x 81										
9,10	125 x 81				12,62	26,93			38,85		146,12
9,13	23/64"										
9,15	125 x 81										
9,20	125 x 81				12,62	26,93	31,27		38,85		146,12
9,25	125 x 81				12,62				38,85		
9,30	125 x 81				12,62	26,93			38,85		146,12
9,35	125 x 81										
9,40	125 x 81					26,93			38,85		146,12
9,45	125 x 81										

Rosa

Brocas Metal

Ø 8,15-9,45mm

BROCAS HELICOIDAIS COM CABO CILINDRICO DIN 338

Brocas Metal

Cinza

Rosso

**DIN
338**

		BC2	BC82	BC02	BC9	BC5	BC99	BC58	BC16	BC66	BC15	BC18
MATERIAL		HSS	HSS	HSS-G	HSS	HSSCo 5%	HSSCo 5%	HSSCo 8%	HSS	HSS	HSS	HSS
AFIAÇÃO												
ÂNGULO PONTA		118°	118°	118°	118°	135°	135°	135°	135°	118°	118°	118°
HÉLICE		30° "N"	30° "N"	30° "N"	30° "N"	30° "N"	30° "N"	30° "N"	40° "W"	15° "H"	30° "N"	30° "N"
ACABAMENTO		OX	BRILHANTE	DOURADO OX	OX	DOURADO	DOURADO	DOURADO	BRILHANTE	BRILHANTE	OX	TiN
APLICAÇÃO												
Ø mm	L1 x L2	€	€	€	€	€	€	€	€	€	€	€
9,50	125 x 81	6,66	6,66	7,45		11,17		17,18	10,38	12,89	16,42	9,46
9,52	3/8"	6,26				10,64						
9,55	133 x 87	11,51										
9,60	133 x 87	11,36	11,36			17,97						12,58
9,65	133 x 87	11,51										
9,70	133 x 87	11,36	11,36			17,97						12,47
9,75	133 x 87	8,29	8,29	9,39		16,93		26,16	16,97	28,85		10,71
9,80	133 x 87	11,12	11,12			17,97						12,39
9,85	133 x 87	11,24										
9,90	133 x 87	11,24	11,24	12,65		17,97						12,39
9,92	25/64"	10,71				16,97						
9,95	133 x 87	11,23										
10,00	133 x 87	7,18	7,18	8,02	12,08	12,34		18,97	11,48	13,39	17,70	9,80
10,10	133 x 87	9,59	9,59	10,79		20,67						
10,20	133 x 87	8,94	8,94	10,01		17,43		34,31				17,20
10,25	133 x 87	9,98	9,98	12,39	15,92	21,32		34,31	18,85	32,89		17,46
10,30	133 x 87	11,19	11,19	12,50		20,72						
10,32	13/32"	10,71				19,64						
10,40	133 x 87	11,19	11,19			20,67						
10,50	133 x 87	8,92	8,92	9,98	13,52	17,44	26,51	27,91	15,32	16,09	24,19	16,34
10,60	133 x 87	12,33	12,33			24,04						
10,70	142 x 94	12,33	12,33			24,04						
10,72	27/64"	10,98				23,56						
10,75	142 x 94	11,53	11,53	12,75	18,00	24,98		39,92	22,04	30,03		18,01
10,80	142 x 94	13,68	13,68			24,04						
10,90	142 x 94	13,68	13,68			24,09						
11,00	142 x 94	10,41	10,41	11,68	15,32	19,26	28,33	30,78	16,63	17,91	27,73	17,26
11,10	142 x 94	13,96	13,96			27,43						
11,11	7 / 16"	13,28				25,87						
11,20	142 x 94	13,96	13,96			27,43						

BROCAS HELICOIDAIS COM CABO CILINDRICO DIN 338



- 10 U. Ø 0,20 - Ø 10,50 mm
- 6 U. Ø 10,60 - Ø 14 mm
- 1 U. Ø 14,10 - Ø 20 mm
- 1 U. BC9-BC99
BC7-BC98-BC42



		BTX	TTX	BC51	BC95	BC55	BC57	BC50	BC7	BC98	BC42
MATERIAL		HSSCo 5%	HSS	HSSCo 5%	HSSCo 5%	HSSCo 5%	HSSCo 5%	HSSCo 5%	PMD	PMD	MD
AFIAÇÃO											
ÂNGULO PONTA		135°	135°	135°	130°	135°	135°	118°	118°	135°	135°
HÉLICE		38° "5"	38° "5"	30° "N"	Ø ≥ 3	38° "5"	38° "5"	38° "N"	30° "N"	30° "N"	35° "N"
ACABAMENTO		DOURADO	TiAlSiN	TiAlN	DOURADO OX	BRILHANTE	TiAlN	TiAlN	BRILHANTE	BRILHANTE	BRILHANTE
APLICAÇÃO		120 Kg/mm²	80 Kg/mm²	ALTA PRODUÇÃO	INOX	INOX	INOX	INOX Plus	FUNDAÇÃO	70 Hrc	ALTA PRODUÇÃO
Ø mm	L1 x L2	€	€	€	€	€	€	€	€	€	€
9,50	125 x 81	12,12	11,52	15,26	12,98	17,65	25,20	29,10	34,81	26,67	122,61
9,52	3/8"										
9,55	133 x 87										
9,60	133 x 87					26,93			41,66		154,97
9,65	133 x 87										
9,70	133 x 87					26,93			41,66		154,97
9,75	133 x 87								41,66		
9,80	133 x 87					26,80	34,53		41,66		154,97
9,85	133 x 87										
9,90	133 x 87					29,10			41,66		154,97
9,92	25/64"										
9,95	133 x 87										
10,00	133 x 87	13,34	12,66	16,01	14,28	19,46	27,11	32,08	34,90	27,37	132,55
10,10	133 x 87								46,67		
10,20	133 x 87	17,99	17,10	27,58	19,27	29,10	43,78	37,35	44,96	35,42	153,23
10,25	133 x 87				19,28				46,67		
10,30	133 x 87								46,67	35,42	
10,32	13/32"										
10,40	133 x 87								46,67		
10,50	133 x 87	18,00	17,11	27,55	19,28	27,57	43,08	37,88	41,70	35,15	146,86
10,60	133 x 87								49,64		
10,70	142 x 94								49,64		
10,72	27/64"										
10,75	142 x 94				21,17				49,64		
10,80	142 x 94					38,74			49,64		
10,90	142 x 94								49,64		
11,00	142 x 94	19,88	18,88	28,72	21,27	30,49	45,63	40,24	44,81	35,30	174,88
11,10	142 x 94				23,95				53,17		
11,11	7 / 16"										
11,20	142 x 94				23,95	47,03			53,17		

Brocas Metal
Rosa

Ø 9,50-11,20mm

BROCAS HELICOIDAIS COM CABO CILINDRICO DIN 338

Brocas Metal

Cinza

Rosca

**DIN
338**

		BC2	BC82	BC02	BC9	BC5	BC99	BC58	BC16	BC66	BC15	BC18
MATERIAL		HSS	HSS	HSS-G	HSS	HSSCo 5%	HSSCo 5%	HSSCo 8%	HSS	HSS	HSS	HSS
AFIAÇÃO												
ÂNGULO PONTA		118°	118°	118°	118°	135°	135°	135°	135°	118°	118°	118°
HÉLICE		30° "N"	30° "N"	30° "N"	30° "N"	30° "N"	30° "N"	30° "N"	40° "N"	15° "H"	30° "N"	30° "N"
ACABAMENTO		OX	BRILHANTE	DOURADO OX	OX	DOURADO	DOURADO	DOURADO	BRILHANTE	BRILHANTE	OX	TiN
APLICAÇÃO				Plus					Al	LATÃO		PRODUÇÃO
Ø mm	L1 x L2	€	€	€	€	€	€	€	€	€	€	€
11,25	142 x 94	11,83	11,83	13,72	19,04	28,45		46,82	29,02	39,55		18,17
11,30	142 x 94	13,68	13,68			27,41						
11,40	142 x 94	13,68	13,68			27,43						
11,50	142 x 94	11,12	11,12	12,49	16,17	23,04	30,63	39,37	19,66	21,53	32,78	17,75
11,51	29/64"	10,59				21,85						
11,60	142 x 94	13,68	13,68			28,31						
11,70	142 x 94	13,68	13,68			28,31						
11,75	142 x 94	11,83	11,83	14,13	20,74	29,42		50,38	28,47	39,55		18,17
11,80	142 x 94	14,99	14,99			28,31						
11,90	151 x 101	14,99	14,99			28,31						
11,91	15/32"	14,27				26,83						
12,00	151 x 101	12,38	12,38	13,95	17,70	24,57	32,84	42,19	21,08	23,32	32,96	18,53
12,10	151 x 101	17,45	17,45			32,90						
12,20	151 x 101	17,45	17,45			32,90						
12,25	151 x 101	15,42	15,42	17,31	22,52	34,04		60,14	39,57	53,91		23,20
12,30	151 x 101	16,43	16,43			32,90						
12,40	151 x 101	16,43	16,43			32,90						
12,50	151 x 101	13,63	13,63	15,27	19,20	30,01	39,96	52,93	23,45	26,45	40,17	22,01
12,60	151 x 101	17,04	17,04			34,20						
12,70	1/2"	15,08				32,57						
12,75	151 x 101	15,15	15,15	17,30	23,21	35,54		62,81	43,67	59,87		23,02
12,80	151 x 101	19,01	19,01			34,20						
12,90	151 x 101	19,01	19,01			34,20						
13,00	151 x 101	14,12	14,12	15,73	19,73	30,70	42,17	53,67	23,79	28,45	41,58	22,35
13,10	151 x 101	19,46	19,46									
13,20	151 x 101	19,46	19,46									
13,25	160 x 108	22,20	22,20		28,22	42,50						
13,30	160 x 108	30,13	30,13									
13,40	160 x 108	30,13	30,13									
13,49	17/32"	19,06				32,23						

BROCAS HELICOIDAIS COM CABO CILINDRICO DIN 338



- 10 U. Ø 0,20 - Ø 10,50 mm
- 6 U. Ø 10,60 - Ø 14 mm
- 1 U. Ø 14,10 - Ø 20 mm
- 1 U. BC9-BC99
BC7-BC98-BC42



	BTX	TTX	BC51	BC95	BC55	BC57	BC50	BC7	BC98	BC42	
MATERIAL	HSSCo 5%	HSS	HSSCo 5%	HSSCo 5%	HSSCo 5%	HSSCo 5%	HSSCo 5%	PMD	PMD	MD	
AFIAÇÃO											
ÂNGULO PONTA	135°	135°	135°	130°	135°	135°	118°	118°	135°	135°	
HÉLICE	38° "S"	38° "S"	30° "N"	Ø ≥ 3	38° "S"	38° "S"	38° "N"	30° "N"	30° "N"	35° "N"	
ACABAMENTO	DOURADO	TiAlSiN	TiAlN	DOURADO OX	BRILHANTE	TiAlN	TiAlN	BRILHANTE	BRILHANTE	BRILHANTE	
APLICAÇÃO	120 Kg/mm²	80 Kg/mm²	ALTA PRODUÇÃO	INOX	INOX	INOX	INOX Plus	FUNDAÇÃO	70 Hrc	ALTA PRODUÇÃO	
Ø mm	L1 x L2		€	€	€	€	€	€	€	€	
11,25	142 x 94				23,95				53,17		
11,30	142 x 94				23,95				53,17		
11,40	142 x 94							53,17			
11,50	142 x 94	22,88	21,73	30,50	24,49	36,31	51,32	46,15	51,50	40,57	193,19
11,51	29/64"										
11,60	142 x 94							58,62	44,50		
11,70	142 x 94							58,62			
11,75	142 x 94				25,86			58,62			
11,80	142 x 94					48,51		58,62			
11,90	151 x 101							58,62			
11,91	15/32"										
12,00	151 x 101	24,53	23,30	31,55	26,25	38,74	53,95	48,08	51,23	40,38	230,19
12,10	151 x 101							61,73	46,84		
12,20	151 x 101							61,73			
12,25	151 x 101							61,73			
12,30	151 x 101							61,73			
12,40	151 x 101							61,73			
12,50	151 x 101	29,93	28,45	39,00	32,04	48,57	58,32	54,41	61,43		314,51
12,60	151 x 101							65,21			
12,70	1/2"							65,21			
12,75	151 x 101							65,21			
12,80	151 x 101							65,21			
12,90	151 x 101							65,21			
13,00	151 x 101	30,37	28,85	39,57	32,52	49,92	67,38	58,57	61,32		248,91
13,10	151 x 101										
13,20	151 x 101										
13,25	160 x 108										
13,30	160 x 108										
13,40	160 x 108										
13,49	17/32"										

Brocas Metal

Rosa

Ø 11,25-13,49mm

BROCAS HELICOIDAIS COM CABO CILINDRICO DIN 338

Brocas Metal

Cinza

Rosso

**DIN
338**

		BC2	BC82	BC02	BC9	BC5	BC99	BC58	BC16	BC66	BC15	BC18
MATERIAL		HSS	HSS	HSS-G	HSS	HSSCo 5%	HSSCo 5%	HSSCo 8%	HSS	HSS	HSS	HSS
AFIAÇÃO												
ÂNGULO PONTA		118°	118°	118°	118°	135°	135°	135°	135°	118°	118°	118°
HÉLICE												
ACABAMENTO		OX	BRILHANTE	DOURADO OX	OX	DOURADO	DOURADO	DOURADO	BRILHANTE	BRILHANTE	OX	TiN
APLICAÇÃO				<i>Plus</i>								
Ø mm	L1 x L2	€	€	€	€	€	€	€	€	€	€	€
13,50	160 x 108	20,01	20,01	22,45	26,32	33,84	44,78	59,16				27,26
13,60	160 x 108	30,13	30,13									
13,70	160 x 108	30,13	30,13									
13,75	160 x 108	22,45	22,45		30,26	42,50						
13,80	160 x 108	28,72	28,72									
13,89	35/64"	27,48				38,05						
13,90	160 x 108	28,84	28,84									
14,00	160 x 108	21,43	21,43	24,03	27,95	33,44	47,08	58,48				28,17
14,10	169 x 114	30,74										
14,20	169 x 114	30,74										
14,25	169 x 114	25,14	25,14		32,31	55,80						
14,29	9/16"	29,78				42,08						
14,30	169 x 114	31,27										
14,40	169 x 114	31,27										
14,50	169 x 114	23,15	23,15		30,22	47,44	63,18	82,92				29,21
14,60	169 x 114	31,85										
14,68	37/64"	23,94				53,15						
14,70	169 x 114	31,85										
14,75	169 x 114	25,14	25,14		37,11	55,80						
14,80	169 x 114	30,69										
14,90	169 x 114	30,69										
15,00	169 x 114	23,36	23,36	26,17	30,51	48,15	65,98	84,16				29,48
15,08	19/32"	22,25				45,86						
15,25	178 x 120	34,22			38,68	77,03						
15,48	39/64"	33,09				73,36						
15,50	178 x 120	27,36	27,36		35,24	55,69	73,63	97,31				32,06
15,75	178 x 120	34,75			40,08	77,01						
15,88	5/8"	27,08				55,06						
16,00	178 x 120	28,44	28,44		36,52	57,80	75,85	101,15				32,69
16,25	184 x 125	51,10			47,02							

BROCAS HELICOIDAIS COM CABO CILINDRICO DIN 338



10 U. Ø 0,20 - Ø 10,50 mm

6 U. Ø 10,60 - Ø 14 mm

1 U. Ø 14,10 - Ø 20 mm

1 U. BC9-BC99
BC7-BC98-BC42



	BTX	TTX	BC51	BC95	BC55	BC57	BC50	BC7	BC98	BC42
MATERIAL	HSSCo 5%	HSS	HSSCo 5%	HSSCo 5%	HSSCo 5%	HSSCo 5%	HSSCo 5%	PMD	PMD	MD
AFIAÇÃO										
ÂNGULO PONTA	135°	135°	135°	130°	135°	135°	118°	118°	135°	135°
HÉLICE	38° "5"	38° "5"	30° "N"	Ø ≥ 3	38° "5"	38° "5"	38° "N"	30° "N"	30° "N"	35° "N"
ACABAMENTO	DOURADO	TiAlSiN	TiAlN	DOURADO OX	BRILHANTE	TiAlN	TiAlN	BRILHANTE	BRILHANTE	BRILHANTE
APLICAÇÃO	120 Kg/mm²	80 Kg/mm²	ALTA PRODUÇÃO	INOX	INOX	INOX	INOX Plus	FUNDAÇÃO	70 HRC	ALTA PRODUÇÃO
Ø mm	L1 x L2	€	€	€	€	€	€	€	€	€
13,50	160 x 108							70,19		
13,60	160 x 108									
13,70	160 x 108									
13,75	160 x 108									
13,80	160 x 108									
13,89	35/64"									
13,90	160 x 108									
14,00	160 x 108							71,38		
14,10	169 x 114									
14,20	169 x 114									
14,25	169 x 114									
14,29	9/16"									
14,30	169 x 114									
14,40	169 x 114									
14,50	169 x 114							79,71		
14,60	169 x 114									
14,68	37/64"									
14,70	169 x 114									
14,75	169 x 114									
14,80	169 x 114									
14,90	169 x 114									
15,00	169 x 114							81,72		
15,08	19/32"									
15,25	178 x 120									
15,48	39/64"									
15,50	178 x 120							99,26		
15,75	178 x 120									
15,88	5/8"									
16,00	178 x 120							94,28		
16,25	184 x 125									

BROCAS HELICOIDAIS COM CABO CILINDRICO DIN 338

Brocas Metal

Cinza

Rosso

**DIN
338**

		BC2	BC82	BC02	BC9	BC5	BC99	BC58	BC16	BC66	BC15	BC18
MATERIAL		HSS	HSS	HSS-G	HSS	HSSCo 5%	HSSCo 5%	HSSCo 8%	HSS	HSS	HSS	HSS
AFIAÇÃO												
ÂNGULO PONTA		118°	118°	118°	118°	135°	135°	135°	135°	118°	118°	118°
HÉLICE												
ACABAMENTO		OX	BRILHANTE	DOURADO OX	OX	DOURADO	DOURADO	DOURADO	BRILHANTE	BRILHANTE	OX	TiN
APLICAÇÃO				<i>Plus</i>					Al	LATÃO		PRODUÇÃO
Ø mm	L1 x L2	€	€	€	€	€	€	€	€	€	€	€
16,50	184 x 125	33,09	33,09		40,91	66,00	86,48					
16,75	184 x 125	53,53			46,12							
17,00	184 x 125	33,14	33,14		40,91	66,00	87,05					
17,25	191 x 130	55,54			51,94							
17,50	191 x 130	37,98	37,98		46,56	73,12	95,82					
17,75	191 x 130	61,51			54,79							
18,00	191 x 130	40,23	40,23		49,08	79,66	104,99					
18,25	198 x 135	60,34			66,86							
18,50	198 x 135	44,61	44,61		54,16	87,98	117,15					
18,75	198 x 135	62,01			61,85							
19,00	198 x 135	44,61	44,61		54,16	87,98	116,14					
19,25	205 x 140	81,03			66,02							
19,50	205 x 140	47,98	47,98		58,77	97,58	128,69					
19,75	205 x 140	78,88			73,94							
20,00	205 x 140	54,48	54,48		70,34	104,72	137,87					
20,50	205 x 140				81,59		148,50					
21,00	205 x 140				74,49		150,54					
21,50	209 x 140				86,62		165,65					
22,00	209 x 140				82,35		168,11					
22,50	214 x 140				88,10		179,80					
23,00	214 x 140				90,19		184,26					
23,50	220 x 145				100,12		204,54					
24,00	220 x 145				98,99		207,58					
24,50	225 x 150				106,65		223,65					
25,00	225 x 150				108,25		222,63					
26,00	243 x 157				129,85		323,98					
27,00	243 x 157				139,46		332,70					
28,00	253 x 167				144,28		366,53					
29,00	253 x 167				169,38		394,21					
30,00	258 x 171				178,06		408,02					

BROCAS HELICOIDAIS COM CABO CILINDRICO DIN 338



10 U. Ø 0,20 - Ø 10,50 mm

6 U. Ø 10,60 - Ø 14 mm

1 U. Ø 14,10 - Ø 20 mm

BC9-BC99
BC7-BC98-BC42



BTX TTX BC51 BC95 BC55 BC57 BC50 BC7 BC98 BC42

	BTX	TTX	BC51	BC95	BC55	BC57	BC50	BC7	BC98	BC42
MATERIAL	HSSCo 5%	HSS	HSSCo 5%	HSSCo 5%	HSSCo 5%	HSSCo 5%	HSSCo 5%	PMD	PMD	MD
AFIAÇÃO										
ÂNGULO PONTA	135°	135°	135°	130°	135°	135°	118°	118°	135°	135°
HÉLICE	38° "5"	38° "5"	30° "N"	Ø ≥ 3	38° "5"	38° "5"	38° "N"	30° "N"	30° "N"	35° "N"
ACABAMENTO	DOURADO	TiAlSiN	TiAlN	DOURADO OX	BRILHANTE	TiAlN	TiAlN	BRILHANTE	BRILHANTE	BRILHANTE
APLICAÇÃO	120 Kg/mm²	80 Kg/mm²	ALTA PRODUÇÃO	INOX	INOX	INOX	INOX Plus	FUNDAÇÃO	70 Hrc	ALTA PRODUÇÃO
Ø mm	L1 x L2	€	€	€	€	€	€	€	€	€
16,50	184 x 125							137,82		
16,75	184 x 125									
17,00	184 x 125							103,50		
17,25	191 x 130									
17,50	191 x 130							154,54		
17,75	191 x 130									
18,00	191 x 130							113,83		
18,25	198 x 135									
18,50	198 x 135							184,24		
18,75	198 x 135									
19,00	198 x 135							138,34		
19,25	205 x 140									
19,50	205 x 140							209,68		
19,75	205 x 140									
20,00	205 x 140							157,45		
20,50	205 x 140									
21,00	205 x 140									
21,50	209 x 140									
22,00	209 x 140									
22,50	214 x 140									
23,00	214 x 140									
23,50	220 x 145									
24,00	220 x 145									
24,50	225 x 150									
25,00	225 x 150									
26,00	243 x 157									
27,00	243 x 157									
28,00	253 x 167									
29,00	253 x 167									
30,00	258 x 171									

BROCAS MICROMÉTRICAS DE METAL DURO E REFRIGERAÇÃO INTERIOR DIN6537K/DIN6537L

Brocas Metal

NEW

Ref. BC84
Ref. BC97

MD

TOL D₁
m7TOL D₂
h6

TiAlN

HARDOX
450

3xD



5xD

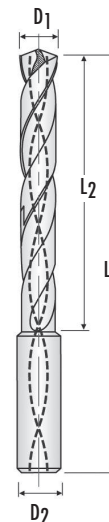

Broca especial para HARDOX 450

BC84

DIN 6537K	D ₁ mm	D ₂ mm	L ₁ mm	L ₂ mm	€
BC840100	1,00	3	47	6,0	52,37
BC840110	1,10	3	47	6,6	52,37
BC840120	1,20	3	47	7,2	55,67
BC840130	1,30	3	47	7,8	55,67
BC840140	1,40	3	47	8,4	55,67
BC840150	1,50	3	47	9,0	55,67
BC840160	1,60	3	47	9,6	58,71
BC840170	1,70	3	47	10,2	58,71
BC840180	1,80	3	52	10,8	58,71
BC840190	1,90	3	52	11,4	58,71
BC840200	2,00	4	59	12,0	66,44
BC840210	2,10	4	59	12,6	66,44
BC840220	2,20	4	59	13,2	66,44
BC840230	2,30	4	59	13,8	66,44
BC840240	2,40	4	59	14,4	71,62
BC840250	2,50	4	59	15,0	71,62
BC840260	2,60	4	59	15,6	71,62
BC840270	2,70	4	59	16,2	71,62
BC840280	2,80	4	59	16,8	74,15
BC840290	2,90	4	59	17,4	74,15

BC97

DIN 6537L	D ₁ mm	D ₂ mm	L ₁ mm	L ₂ mm	€
BC970100	1,00	3	47	8,0	53,11
BC970110	1,10	3	47	8,8	55,67
BC970120	1,20	3	52	10,8	58,71
BC970130	1,30	3	52	11,7	60,76
BC970140	1,40	3	52	12,6	60,76
BC970150	1,50	3	52	13,5	60,76
BC970160	1,60	3	52	14,4	66,44
BC970170	1,70	3	52	15,3	66,44
BC970180	1,80	3	52	16,2	66,44
BC970190	1,90	3	52	17,1	66,44
BC970200	2,00	4	63	18,0	74,15
BC970210	2,10	4	63	18,9	74,15
BC970220	2,20	4	63	19,8	74,15
BC970230	2,30	4	63	20,7	75,46
BC970240	2,40	4	63	21,6	77,99
BC970250	2,50	4	63	22,5	77,99
BC970260	2,60	4	67	23,4	80,52
BC970270	2,70	4	67	24,3	80,52
BC970280	2,80	4	67	25,2	83,14
BC970290	2,90	4	67	26,1	83,14

BROCAS DE METAL DURO E REFRIGERAÇÃO INTERIOR DIN6537K

Ref. BC84
Ref. BC83

3xD

DIN 6537K

MD

TOL D1 m7

TOL D2 h6



30° "N"





TiAIN

HARDOX 450



ALTA PRODUÇÃO

Broca especial para HARDOX 450

BC84						BC83		BC84						BC83	
	D1 mm	D2 mm	L1 mm	L2 mm	€		€		D1 mm	D2 mm	L1 mm	L2 mm	€		€
BC840300	3,00	6	62	20	49,57	BC830300	87,80	BC840940	9,4	10	89	47	66,90	BC830940	116,83
BC840310	3,10	6	62	20	49,57	BC830310	87,80	BC840950	9,5	10	89	47	66,90	BC830950	116,83
BC840320	3,20	6	62	20	49,57	BC830320	87,80	BC840960	9,6	10	89	47	66,90	BC830960	116,83
BC840340	3,40	6	62	20	49,57	BC830300	87,80	BC840970	9,7	10	89	47	66,90	BC830970	116,83
BC840350	3,50	6	62	20	49,57	BC830350	87,80	BC840980	9,8	10	89	47	66,90	BC830980	116,83
BC840380	3,80	6	66	24	49,57	BC830380	87,80	BC840990	9,9	10	89	47	66,90	BC830990	116,83
BC840400	4,00	6	66	24	49,57	BC830400	87,80	BC841000	10,0	10	89	47	66,90	BC831000	116,83
BC840420	4,20	6	66	24	49,57	BC830420	87,80	BC841020	10,2	12	102	55	100,34	BC831020	166,96
BC840425	4,25	6	66	24	49,57	BC830425	87,80	BC841040	10,4	12	102	55	100,34	BC831040	166,96
BC840440	4,40	6	66	24	49,54	BC830440	87,80	BC841050	10,5	12	102	55	100,34	BC831050	166,96
BC840450	4,50	6	66	24	49,57	BC830450	87,80	BC841060	10,6	12	102	55	100,34	BC831060	166,96
BC840470	4,70	6	66	24	49,57	BC830470	87,80	BC841070	10,7	12	102	55	100,34	BC831070	166,96
BC840480	4,80	6	66	28	49,57	BC830480	87,80	BC841080	10,8	12	102	55	100,34	BC831080	166,96
BC840490	4,90	6	66	28	49,57	BC830490	87,80	BC841100	11,0	12	102	55	100,34	BC831100	166,96
BC840500	5,00	6	66	28	49,57	BC830500	87,80	BC841110	11,1	12	102	55	100,34	BC831110	166,96
BC840520	5,20	6	66	28	49,57	BC830520	87,80	BC841120	11,2	12	102	55	100,34	BC831120	166,96
BC840550	5,50	6	66	28	49,57	BC830550	87,80	BC841130	11,3	12	102	55	100,34	BC831130	166,96
BC840560	5,60	6	66	28	49,57	BC830560	87,80	BC841150	11,5	12	102	55	100,34	BC831150	166,96
BC840570	5,70	6	66	28	49,57	BC830570	87,80	BC841170	11,7	12	102	55	100,34	BC831170	166,96
BC840580	5,80	6	66	28	49,57	BC830580	87,80	BC841180	11,8	12	102	55	100,34	BC831180	166,96
BC840590	5,90	6	66	28	49,57	BC830590	87,80	BC841200	12,0	12	102	55	100,34	BC831200	166,96
BC840600	6,00	6	66	28	49,57	BC830600	87,80	BC841210	12,1	14	107	60	133,80	BC831210	232,31
BC840610	6,10	8	79	34	58,05	BC830610	104,30	BC841230	12,3	14	107	60	133,80	BC831230	232,31
BC840620	6,20	8	79	34	58,05	BC830620	104,30	BC841240	12,4	14	107	60	133,80	BC831240	232,31
BC840630	6,30	8	79	34	58,05	BC830630	104,30	BC841250	12,5	14	107	60	133,80	BC831250	232,31
BC840650	6,50	8	79	34	58,05	BC830650	104,30	BC841270	12,7	14	107	60	133,80	BC831270	232,31
BC840660	6,60	8	79	34	58,05	BC830660	104,30	BC841280	12,8	14	107	60	133,80	BC831280	232,31
BC840670	6,70	8	79	34	58,05	BC830670	104,30	BC841300	13,0	14	107	60	133,80	BC831300	232,31
BC840680	6,80	8	79	34	58,05	BC830680	104,30	BC841310	13,1	14	107	60	133,80	BC831310	232,31
BC840690	6,90	8	79	34	58,05	BC830690	104,30	BC841330	13,3	14	107	60	133,80	BC831330	232,31
BC840700	7,00	8	79	34	58,05	BC830700	104,30	BC841350	13,5	14	107	60	133,80	BC831350	232,31
BC840710	7,10	8	79	41	58,05	BC830710	104,30	BC841370	13,7	14	107	60	133,80	BC831370	232,31
BC840740	7,40	8	79	41	58,05	BC830740	104,30	BC841380	13,8	14	107	60	133,80	BC831380	232,31
BC840750	7,50	8	79	41	58,05	BC830750	104,30	BC841400	14,0	14	107	60	133,80	BC831400	232,31
BC840780	7,80	8	79	41	58,05	BC830780	104,30	BC841450	14,5	16	115	65	167,53	BC831450	287,49
BC840790	7,90	8	79	41	58,05	BC830790	104,30	BC841470	14,7	16	115	65	167,53	BC831470	287,49
BC840800	8,00	8	79	41	58,05	BC830800	104,30	BC841480	14,8	16	115	65	167,53	BC831480	287,49
BC840810	8,10	10	89	47	66,90	BC830810	116,83	BC841500	15,0	16	115	65	167,53	BC831500	287,49
BC840820	8,20	10	89	47	66,90	BC830820	116,83	BC841550	15,5	16	115	65	167,53	BC831550	287,49
BC840830	8,30	10	89	47	66,90	BC830830	116,83	BC841600	16,0	16	115	65	167,53	BC831600	287,49
BC840840	8,40	10	89	47	66,90	BC830840	116,83	BC841650	16,5	18	123	73	256,09	BC831650	453,30
BC840850	8,50	10	89	47	66,90	BC830850	116,83	BC841700	17,0	18	123	73	256,09	BC831700	453,30
BC840860	8,60	10	89	47	66,90	BC830860	116,83	BC841750	17,5	18	123	73	256,09	BC831750	453,30
BC840870	8,70	10	89	47	66,90	BC830870	116,83	BC841800	18,0	18	123	73	256,09	BC831800	453,30
BC840880	8,80	10	89	47	66,90	BC830880	116,83	BC841850	18,5	20	131	79	312,68	BC831850	498,14
BC840890	8,90	10	89	47	66,90	BC830890	116,83	BC841900	19,0	20	131	79	312,68	BC831900	498,14
BC840900	9,00	10	89	47	66,90	BC830900	116,83	BC841950	19,5	20	131	79	312,68	BC831950	498,14
BC840910	9,10	10	89	47	66,90	BC830910	116,83	BC842000	20,0	20	131	79	312,68	BC832000	498,14
BC840930	9,30	10	89	47	66,90	BC830930	116,83								



Rosa

Brocas Metal

BROCAS DE METAL DURO E REFRIGERAÇÃO INTERIOR DIN6537L
5xD

 Ref. BC97
 Ref. BC89

**DIN
6537L**
MD
**TOL D1
m7**
**TOL D2
h6**

TiAIN
**HARDOX
450**

Broca especial para HARDOX 450



BC97

BC89

BC97						BC89		BC97						BC89	
	D1 mm	D2 mm	L1 mm	L2 mm	€		€		D1 mm	D2 mm	L1 mm	L2 mm	€		€
BC970300	3,0	6	66	28	57,57	BC890300	99,25	BC970900	9,0	10	103	61	81,94	BC890900	129,25
BC970310	3,1	6	66	28	57,57	BC890310	99,25	BC970910	9,1	10	103	61	81,94	BC890910	129,25
BC970320	3,2	6	66	28	57,57	BC890320	99,25	BC970920	9,2	10	103	61	81,94	BC890920	129,25
BC970340	3,4	6	66	28	57,57	BC890340	99,25	BC970930	9,3	10	103	61	81,94	BC890930	129,25
BC970350	3,5	6	66	28	57,57	BC890350	99,25	BC970940	9,4	10	103	61	81,94	BC890940	129,25
BC970360	3,6	6	66	28	57,57	BC890360	99,25	BC970950	9,5	10	103	61	81,94	BC890950	129,25
BC970380	3,8	6	74	36	57,57	BC890380	99,25	BC970960	9,6	10	103	61	81,94	BC890960	129,25
BC970390	3,9	6	74	36	57,57	BC890390	99,25	BC970970	9,7	10	103	61	81,94	BC890970	129,25
BC970400	4,0	6	74	36	57,57	BC890400	99,25	BC970980	9,8	10	103	61	81,94	BC890980	129,25
BC970420	4,2	6	74	36	57,57	BC890420	99,25	BC970990	9,9	10	103	61	81,94	BC890990	129,25
BC970440	4,4	6	74	36	57,57	BC890440	99,25	BC971000	10,0	10	103	61	81,94	BC891000	129,25
BC970450	4,5	6	74	36	57,57	BC890450	99,25	BC971010	10,1	12	118	71	117,96	BC891010	184,04
BC970460	4,6	6	74	36	57,57	BC890460	99,25	BC971020	10,2	12	118	71	117,96	BC891020	184,04
BC970470	4,7	6	74	36	57,57	BC890470	99,25	BC971040	10,4	12	118	71	117,96	BC891040	184,04
BC970480	4,8	6	82	44	57,57	BC890480	99,25	BC971050	10,5	12	118	71	117,96	BC891050	184,04
BC970490	4,9	6	82	44	57,57	BC890490	99,25	BC971060	10,6	12	118	71	117,96	BC891060	184,04
BC970500	5,0	6	82	44	57,57	BC890500	99,25	BC971070	10,7	12	118	71	117,96	BC891070	184,04
BC970520	5,2	6	82	44	57,57	BC890520	99,25	BC971080	10,8	12	118	71	117,96	BC891080	184,04
BC970530	5,3	6	82	44	57,57	BC890530	99,25	BC971100	11,0	12	118	71	117,96	BC891100	184,04
BC970540	5,4	6	82	44	57,57	BC890540	99,25	BC971110	11,1	12	118	71	117,96	BC891110	184,04
BC970550	5,5	6	82	44	57,57	BC890550	99,25	BC971120	11,2	12	118	71	117,96	BC891120	184,04
BC970560	5,6	6	82	44	57,57	BC890560	99,25	BC971130	11,3	12	118	71	117,96	BC891130	184,04
BC970570	5,7	6	82	44	57,57	BC890570	99,25	BC971140	11,4	12	118	71	117,96	BC891140	184,04
BC970580	5,8	6	82	44	57,57	BC890580	99,25	BC971150	11,5	12	118	71	117,96	BC891150	184,04
BC970590	5,9	6	82	44	57,57	BC890590	99,25	BC971160	11,5	12	118	71	117,96	BC891160	184,04
BC970600	6,0	6	82	44	57,57	BC890600	99,25	BC971170	11,5	12	118	71	117,96	BC891170	184,04
BC970610	6,1	8	91	53	63,06	BC890610	111,20	BC971180	11,8	12	118	71	117,96	BC891180	184,04
BC970620	6,2	8	91	53	63,06	BC890620	111,20	BC971200	12,0	12	118	71	117,96	BC891200	184,04
BC970630	6,3	8	91	53	63,06	BC890630	111,20	BC971210	12,1	14	124	77	155,06	BC891210	249,97
BC970640	6,4	8	91	53	63,06	BC890640	111,20	BC971230	12,3	14	124	77	155,06	BC891230	249,97
BC970650	6,5	8	91	53	63,06	BC890650	111,20	BC971240	12,4	14	124	77	155,06	BC891240	249,97
BC970660	6,6	8	91	53	63,06	BC890660	111,20	BC971250	12,5	14	124	77	155,06	BC891250	249,97
BC970670	6,7	8	91	53	63,06	BC890670	111,20	BC971270	12,7	14	124	77	155,06	BC891270	249,97
BC970680	6,8	8	91	53	63,06	BC890680	111,20	BC971300	13,0	14	124	77	155,06	BC891300	249,97
BC970690	6,9	8	91	53	63,06	BC890690	111,20	BC971310	13,1	14	124	77	155,06	BC891310	249,97
BC970700	7,0	8	91	53	63,06	BC890700	111,20	BC971330	13,3	14	124	77	155,06	BC891330	249,97
BC970710	7,1	8	91	53	63,06	BC890710	111,20	BC971350	13,5	14	124	77	155,06	BC891350	249,97
BC970720	7,2	8	91	53	63,06	BC890720	111,20	BC971370	13,7	14	124	77	155,06	BC891370	249,97
BC970730	7,3	8	91	53	63,06	BC890730	111,20	BC971380	13,8	14	124	77	155,06	BC891380	249,97
BC970740	7,4	8	91	53	63,06	BC890740	111,20	BC971400	14,0	14	124	77	155,06	BC891400	249,97
BC970750	7,5	8	91	53	63,06	BC890750	111,20	BC971450	14,5	16	133	83	194,38	BC891450	313,48
BC970760	7,6	8	91	53	63,06	BC890760	111,20	BC971470	14,7	16	133	83	194,38	BC891470	313,48
BC970770	7,7	8	91	53	63,06	BC890770	111,20	BC971480	14,8	16	133	83	194,38	BC891480	313,48
BC970780	7,8	8	91	53	63,06	BC890780	111,20	BC971500	15,0	16	133	83	194,38	BC891500	313,48
BC970790	7,9	8	91	53	63,06	BC890790	111,20	BC971550	15,5	16	133	83	194,38	BC891550	313,48
BC970800	8,0	8	91	53	63,06	BC890800	111,20	BC971580	15,8	16	133	83	194,38	BC891580	313,48
BC970810	8,1	10	103	61	81,94	BC890810	129,25	BC971600	16,0	16	133	83	194,38	BC891600	313,48
BC970830	8,3	10	103	61	81,94	BC890830	129,25	BC971650	16,5	18	143	93	323,79	BC891650	494,93
BC970840	8,4	10	103	61	81,94	BC890840	129,25	BC971700	17,0	18	143	93	323,79	BC891700	494,93
BC970850	8,5	10	103	61	81,94	BC890850	129,25	BC971750	17,5	18	143	93	323,79	BC891750	494,93
BC970860	8,6	10	103	61	81,94	BC890860	129,25	BC971800	18,0	18	143	93	323,79	BC891800	494,93
BC970870	8,7	10	103	61	81,94	BC890870	129,25	BC971850	18,5	20	153	101	353,91	BC891850	540,99
BC970880	8,8	10	103	61	81,94	BC890880	129,25	BC971900	19,0	20	153	101	353,91	BC891900	540,99
BC970890	8,9	10	103	61	81,94	BC890890	129,25	BC971950	19,5	20	153	101	353,91	BC891950	540,99
								BC972000	20,0	20	153	101	353,91	BC892000	540,99

BROCA DE METAL DURO E REFRIGERAÇÃO INTERIOR DIN6537L

Ref. BC96

7xD

MD

**TOL D1
m7**

**TOL D2
h6**



TiAIN

**HARDOX
450**



Broca especial para HARDOX 450

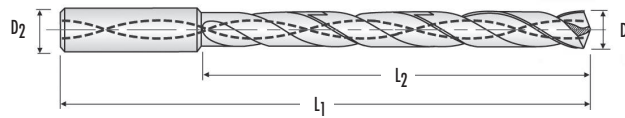

BC96					
	D1 mm	D2 mm	L1 mm	L2 mm	€
BC960300	3,00	6	72	34	187,74
BC960320	3,20	6	72	34	187,74
BC960350	3,50	6	72	34	187,74
BC960380	3,80	6	81	43	187,74
BC960400	4,00	6	81	43	187,74
BC960420	4,20	6	81	43	187,74
BC960450	4,50	6	81	43	187,74
BC960480	4,80	6	95	57	187,74
BC960500	5,00	6	95	57	187,74
BC960520	5,20	6	95	57	187,74
BC960550	5,50	6	95	57	187,74
BC960560	5,60	6	95	57	187,74
BC960570	5,70	6	95	57	187,74
BC960580	5,80	6	95	57	187,74
BC960590	5,90	6	95	57	187,74
BC960600	6,00	6	95	57	187,74
BC960610	6,10	8	114	76	204,52
BC960620	6,20	8	114	76	204,52
BC960630	6,30	8	114	76	204,52
BC960650	6,50	8	114	76	204,52
BC960660	6,60	8	114	76	204,52
BC960680	6,80	8	114	76	204,52
BC960690	6,90	8	114	76	204,52
BC960700	7,00	8	114	76	204,52
BC960710	7,10	8	114	76	204,52
BC960740	7,40	8	114	76	204,52
BC960750	7,50	8	114	76	204,52
BC960780	7,80	8	114	76	204,52
BC960800	8,00	8	114	76	204,52
BC960810	8,10	10	142	95	276,93
BC960840	8,40	10	142	95	276,93
BC960850	8,50	10	142	95	276,93
BC960860	8,60	10	142	95	276,93
BC960870	8,70	10	142	95	276,93
BC960880	8,80	10	142	95	276,93
BC960900	9,00	10	131	87	276,93
BC960930	9,30	10	142	95	276,93
BC960950	9,50	10	142	95	276,93
BC960960	9,60	10	142	95	276,93
BC960980	9,80	10	142	95	276,93
BC961000	10,00	10	142	95	276,93
BC961020	10,20	12	162	114	365,08
BC961040	10,40	12	162	114	365,08
BC961050	10,50	12	162	114	365,08
BC961060	10,60	12	162	114	365,08
BC961080	10,80	12	162	114	365,08
BC961100	11,00	12	162	114	365,08
BC961120	11,20	12	162	114	365,08
BC961150	11,50	12	162	114	365,08
BC961180	11,80	12	162	114	365,08
BC961200	12,00	12	162	114	365,08



BROCA DE METAL DURO E REFRIGERAÇÃO INTERIOR DIN6537L

Ref. BXX

12xD
**DIN
6537L**
MD
**TOL D1
m7**
**TOL D2
h6**

TiAIN
**HARDOX
450**

Broca especial para HARDOX 450

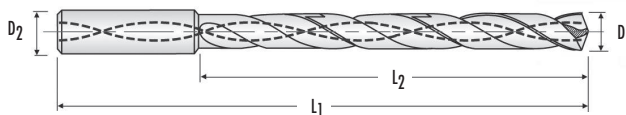

BXX					
	D1 mm	D2 mm	L1 mm	L2 mm	€
BXX0300	3,0	6	92	54	206,08
BXX0320	3,2	6	92	54	206,08
BXX0330	3,3	6	92	54	206,08
BXX0350	3,5	6	92	54	206,08
BXX0370	3,7	6	92	54	206,08
BXX0380	3,8	6	102	64	206,08
BXX0390	3,9	6	102	64	206,08
BXX0400	4,0	6	102	64	206,08
BXX0420	4,2	6	102	64	206,08
BXX0430	4,3	6	102	64	206,08
BXX0440	4,4	6	102	64	219,84
BXX0450	4,5	6	102	64	219,84
BXX0460	4,6	6	102	64	219,84
BXX0470	4,7	6	102	64	219,84
BXX0480	4,8	6	116	78	219,84
BXX0490	4,9	6	116	78	219,84
BXX0500	5,0	6	116	78	219,84
BXX0510	5,1	6	116	78	219,84
BXX0520	5,2	6	116	78	219,84
BXX0530	5,3	6	116	78	219,84
BXX0540	5,4	6	116	78	219,84
BXX0550	5,5	6	116	78	219,84
BXX0560	5,6	6	116	78	219,84
BXX0570	5,7	6	116	78	219,84
BXX0580	5,8	6	116	78	219,84
BXX0590	5,9	6	116	78	219,84
BXX0600	6,0	6	116	78	219,84
BXX0610	6,1	8	146	108	269,31
BXX0620	6,2	8	146	108	269,31
BXX0650	6,5	8	146	108	269,31
BXX0660	6,6	8	146	108	269,31
BXX0670	6,7	8	146	108	269,31
BXX0680	6,8	8	146	108	285,77
BXX0690	6,9	8	146	108	285,77
BXX0700	7,0	8	146	108	285,77

BXX					
	D1 mm	D2 mm	L1 mm	L2 mm	€
BXX0740	7,4	8	146	108	285,77
BXX0750	7,5	8	146	108	285,77
BXX0770	7,7	8	146	108	285,77
BXX0780	7,8	8	146	108	315,42
BXX0800	8,0	8	146	108	319,58
BXX0820	8,2	10	162	120	357,27
BXX0850	8,5	10	162	120	357,27
BXX0880	8,8	10	162	120	357,27
BXX0900	9,0	10	162	120	357,27
BXX0950	9,5	10	162	120	357,27
BXX0980	9,8	10	162	120	357,27
BXX0990	9,9	10	162	120	357,27
BXX1000	10,0	10	162	120	357,27
BXX1010	10,1	12	204	156	500,15
BXX1020	10,2	12	204	156	500,15
BXX1030	10,3	12	204	156	500,15
BXX1050	10,5	12	204	156	500,15
BXX1080	10,8	12	204	156	500,15
BXX1100	11,0	12	204	156	500,15
BXX1120	11,2	12	204	156	500,15
BXX1140	11,4	12	204	156	500,15
BXX1150	11,5	12	204	156	500,15
BXX1180	11,8	12	204	156	500,15
BXX1200	12,0	12	204	156	500,15
BXX1250	12,5	14	230	182	654,04
BXX1280	12,8	14	230	182	654,04
BXX1300	13,0	14	230	182	654,04
BXX1350	13,5	14	230	182	654,04
BXX1380	13,8	14	230	182	654,04
BXX1400	14,0	14	230	182	654,04
BXX1450	14,5	16	260	208	851,85
BXX1500	15,0	16	260	208	851,85
BXX1550	15,5	16	260	208	851,85
BXX1600	16,0	16	260	208	851,85



BROCA DE METAL DURO E REFRIGERAÇÃO INTERIOR DIN6537L

Ref. BXL
Ref. BXXL

**DIN
6537L**

MD

**TOL D1
m7**

**TOL D2
h6**



TiAIN

**HARDOX
450**



Broca especial para HARDOX 450

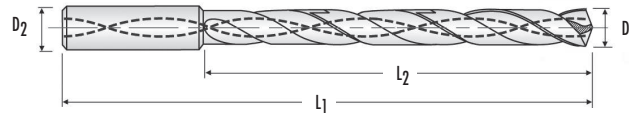

15xD

	D1 mm	D2 mm	L1 mm	L2 mm	BXL €
BXLO300	3,0	6	100	60	279,60
BXLO320	3,2	6	100	60	279,60
BXLO330	3,3	6	100	60	279,60
BXLO350	3,5	6	100	60	279,60
BXLO380	3,8	6	108	68	279,60
BXLO390	3,9	6	108	68	279,60
BXLO400	4,0	6	108	68	279,60
BXLO420	4,2	6	115	78	311,34
BXLO450	4,5	6	115	78	311,34
BXLO500	5,0	6	125	84	320,02
BXLO550	5,5	6	130	92	325,63
BXLO590	5,9	6	140	100	325,63
BXLO600	6,0	6	140	100	325,63
BXLO650	6,5	8	145	108	427,81
BXLO680	6,8	8	170	130	486,52
BXLO700	7,0	8	170	130	486,52
BXLO750	7,5	8	170	130	486,52
BXLO780	7,8	8	170	130	486,52
BXLO800	8,0	8	170	130	486,52
BXLO850	8,5	10	208	163	659,68
BXLO900	9,0	10	208	163	659,68
BXLO950	9,5	10	208	163	659,68
BXLO980	9,8	10	208	163	659,68
BXL1000	10,0	10	208	163	659,68
BXL1050	10,5	12	245	195	847,76
BXL1100	11,0	12	245	195	847,76
BXL1150	11,5	12	245	195	847,76
BXL1180	11,8	12	245	195	847,76
BXL1200	12,0	12	245	195	847,76
BXL1250	12,5	14	280	230	1.161,34
BXL1300	13,0	14	280	230	1.161,34
BXL1400	14,0	14	280	230	1.161,34
BXL1500	15,0	16	310	260	1.414,23

20xD

	D1 mm	D2 mm	L1 mm	L2 mm	BXXL €
BXXLO300	3,0	6	110	70	307,56
BXXLO350	3,5	6	136	96	307,56
BXXLO400	4,0	6	136	96	307,56
BXXLO450	4,5	6	158	118	342,47
BXXLO500	5,0	6	158	118	352,02
BXXLO510	5,1	6	180	140	358,19
BXXLO550	5,5	6	180	140	358,19
BXXLO600	6,0	6	180	140	358,19
BXXLO650	6,5	8	202	162	470,59
BXXLO700	7,0	8	202	162	535,17
BXXLO750	7,5	8	223	183	535,17
BXXLO800	8,0	8	223	183	535,17
BXXLO850	8,5	10	249	205	725,65
BXXLO900	9,0	10	249	205	725,65
BXXL1000	10,0	10	271	227	725,65



BXL

BXXL

BROCAS MICROMÉTRICAS COM CABO REFORÇADO

Brocas Metal

Rosa

Ref. BC30

HSS



5xD

BC30				
	D ₁ mm	L ₁ mm	L ₂ mm	€
BC300050	0,50	43	5	3,37
BC300060	0,60	43	7	3,37
BC300070	0,70	43	7	3,37
BC300075	0,75	43	7	3,37
BC300080	0,80	43	7	3,37
BC300090	0,90	43	7	3,37
BC300095	0,95	43	7	3,37
BC300100	1,00	43	7	3,37
BC300110	1,10	43	7	3,37
BC300120	1,20	43	10	3,37
BC300125	1,25	43	10	3,37
BC300130	1,30	43	10	3,37

BC30				
	D ₁ mm	L ₁ mm	L ₂ mm	€
BC300140	1,40	43	10	3,37
BC300150	1,50	43	10	3,37
BC300160	1,60	43	10	3,37
BC300170	1,70	43	10	3,37
BC300175	1,75	43	10	3,37
BC300180	1,80	43	10	3,37
BC300190	1,90	43	10	3,37
BC300200	2,00	43	10	3,37
BC300210	2,10	43	10	3,37
BC300220	2,20	43	10	3,37
BC300225	2,25	43	10	3,37
BC300235	2,35	43	10	3,37
BC300240	2,40	43	10	3,37



Ref. BC79

MDI

ALTA
PRODUÇÃO

5xD

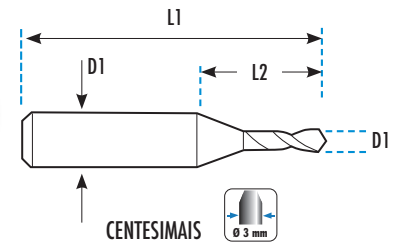

BC79				
	D ₁ mm	L ₁ mm	L ₂ mm	€
BC790025	0,25	38	5	28,84
BC790030	0,30	38	5	28,84
BC790035	0,35	38	5	28,84
BC790040	0,40	38	5	20,96
BC790045	0,45	38	5	20,96
BC790050	0,50	38	5	15,29
BC790055	0,55	38	5	15,29
BC790060	0,60	38	5	15,29
BC790065	0,65	38	5	13,80
BC790070	0,70	38	10	13,80
BC790075	0,75	38	10	13,80
BC790080	0,80	38	10	13,80
BC790085	0,85	38	10	13,80
BC790090	0,90	38	10	13,80
BC790095	0,95	38	10	13,80
BC790100	1,00	38	10	13,80
BC790105	1,05	38	10	13,80
BC790110	1,10	38	10	13,80
BC790115	1,15	38	10	13,80
BC790120	1,20	38	10	13,80
BC790125	1,25	38	10	13,80
BC790130	1,30	38	10	13,80
BC790135	1,35	38	10	13,80
BC790140	1,40	38	10	13,80
BC790145	1,45	38	10	13,80
BC790150	1,50	38	10	13,80
BC790155	1,55	38	10	13,80
BC790160	1,60	38	10	13,80
BC790165	1,65	38	10	17,33
BC790170	1,70	38	10	17,33

BC79				
	D ₁ mm	L ₁ mm	L ₂ mm	€
BC790175	1,75	38	10	17,33
BC790180	1,80	38	10	17,33
BC790185	1,85	38	10	17,33
BC790190	1,90	38	10	17,33
BC790195	1,95	38	10	17,33
BC790200	2,00	38	10	17,33
BC790205	2,05	38	10	17,33
BC790210	2,10	38	10	17,33
BC790215	2,15	38	10	17,33
BC790220	2,20	38	10	17,33
BC790225	2,25	38	10	17,33
BC790230	2,30	38	10	17,33
BC790235	2,35	38	10	17,33
BC790240	2,40	38	10	17,33
BC790245	2,45	38	10	17,33
BC790250	2,50	38	10	17,33
BC790255	2,55	38	10	17,33
BC790260	2,60	38	10	17,33
BC790265	2,65	38	10	17,33
BC790270	2,70	38	10	17,33
BC790275	2,75	38	10	17,33
BC790280	2,80	38	10	17,33
BC790285	2,85	38	10	17,33
BC790290	2,90	38	10	17,33
BC790295	2,95	38	10	17,33
BC790300	3,00	38	10	17,33
BC790305	3,05	38	10	17,33
BC790310	3,10	38	10	17,33
BC790315	3,15	38	10	17,33

BC79	
D ₁ mm	€
0,10 - 0,39	28,84
0,41 - 0,89	21,51
0,91 - 1,19	21,51
1,21 - 1,39	23,22
1,41 - 1,89	23,22
1,91 - 2,19	23,22
2,21 - 2,39	24,20
2,41 - 2,89	24,20
2,91 - 2,99	24,20



BROCA DE METAL DURO PARA AÇOS TEMPERADOS E BLINDADOS DE ALTA RESISTÊNCIA

Ref. BC85

**70
HRC**

MD

**TOL D1
h7**

**TOL D2
h6**



TiAIN

**HARDOX
600**



Broca especial para HARDOX 600

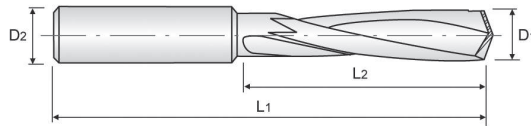

	BC85				
	D1 mm	D2 mm	L1 mm	L2 mm	€
BC850300	3,0	3	46	16	49,79
BC850330	3,3	4	48	18	57,14
BC850340	3,4	4	50	20	57,14
BC850350	3,5	4	50	20	57,14
BC850400	4,0	4	52	22	58,30
BC850420	4,2	6	65	25	82,78
BC850430	4,3	6	68	28	82,78
BC850440	4,4	6	68	28	82,78
BC850450	4,5	6	68	28	82,78
BC850500	5,0	6	72	32	82,78
BC850510	5,1	6	72	32	82,78
BC850520	5,2	6	72	32	82,78
BC850550	5,5	6	75	35	82,78
BC850600	6,0	6	75	35	82,78
BC850630	6,3	8	80	40	102,69*
BC850650	6,5	8	80	40	102,69
BC850680	6,8	8	85	45	102,69
BC850690	6,9	8	85	45	102,69
BC850700	7,0	8	85	45	102,69
BC850750	7,5	8	85	45	102,69
BC850800	8,0	8	98	50	102,69
BC850850	8,5	10	98	50	156,94
BC850860	8,6	10	105	57	156,94
BC850880	8,8	10	105	57	156,94
BC850900	9,0	10	105	57	156,94
BC850950	9,5	10	105	57	156,94
BC851000	10,0	10	111	63	156,94
BC851020	10,2	12	111	63	203,26
BC851030	10,3	12	111	63	238,49
BC851040	10,4	12	111	63	238,49
BC851050	10,5	12	111	63	238,49
BC851080	10,8	12	119	71	238,49
BC851100	11,0	12	119	71	238,49
BC851150	11,5	12	119	71	238,49
BC851200	12,0	12	119	71	238,49
BC851400	14,0	14	125	77	271,01

*Até o fim das existências.

FURAÇÃO DE PARAFUSOS E MACHOS QUEBRADOS

Parafuso quebrado

PASSO 1
Limpar a superfície

PASSO 2
Furar com a broca BC85

PASSO 3
Retirar os restos

PASSO 4 (Opcional)
Reparar a rosca com insertos

BROCA STEP CUT FÁCIL PERFURAÇÃO EM SUPERFÍCIES CURVADAS E INSTÁVEIS
**DIN
338**
HSS

Al

Cu-Ni-Zn

PVC

Ref. TK02

STEP CUT

Broca helicoidal HSS com geometria de ponta STEP CUT, corte escalonado.

NOVA Broca STEP CUT com geometria escalonada inovadora que facilita uma suave penetração.

Trabalhe com conforto, rapidez e precisão em superfícies curvas, instáveis ou inclinadas.

Maior precisão, devido à sua ponta centralizadora que evita o escorregamento no início da furação.

A geometria STEP CUT com corte escalonado gera furos mais centralizados, redondos e precisos.

O triplo plano de amarração ANTISLIP no cabo transmite a potência do berbequim de forma adequada.

Permite fazer furos passantes em aço, alumínio, cobre, níquel, zinco, PVC, fibra de vidro e madeira.

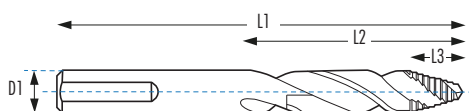

	TK02					
	D1 mm	L1 mm	L2 mm	L3 mm		€
TK020100	1,0	34	12	-	10	3,42
TK020150	1,5	40	18	-	10	3,52
TK020200	2,0	49	24	-	10	3,67
TK020250	2,5	57	30	1,6	10	4,27
TK020300	3,0	61	33	1,9	10	4,48
TK020320	3,2	65	36	2,1	10	5,36
TK020330	3,3	65	36	2,2	10	5,36
TK020350	3,5	70	39	2,1	10	5,36
TK020400	4,0	75	43	2,9	10	6,34
TK020410	4,1	75	43	3,0	10	6,97
TK020420	4,2	75	43	3,0	10	6,97
TK020450	4,5	80	47	3,3	10	6,97
TK020490	4,9	76	52	3,8	10	6,97
TK020500	5,0	76	52	3,9	10	7,87
TK020510	5,1	76	52	4,0	10	8,26
TK020520	5,2	76	52	4,2	10	8,26
TK020550	5,5	93	57	4,6	10	8,33
TK020600	6,0	93	57	5,3	10	9,08
TK020650	6,5	101	63	5,8	10	10,59
TK020680	6,8	109	69	5,9	10	11,57
TK020700	7,0	109	69	6,4	10	12,11
TK020750	7,5	109	69	6,9	10	14,16
TK020800	8,0	117	75	7,6	10	14,63
TK020850	8,5	117	75	8,2	10	17,36
TK020900	9,0	125	81	8,8	10	19,17
TK020950	9,5	125	81	9,3	10	20,68
TK021000	10,0	133	87	10,0	10	22,05
TK021020	10,2	133	87	9,9	10	23,33
TK021050	10,5	133	87	10,7	10	24,02
TK021100	11,0	142	94	11,3	6	26,52
TK021150	11,5	142	94	12,0	6	28,85
TK021200	12,0	151	101	12,6	6	31,48
TK021250	12,5	151	101	13,8	6	33,50
TK021300	13,0	151	101	14,7	6	36,11



BROCA STEP CUT FÁCIL PERFURAÇÃO EM SUPERFÍCIES CURVADAS E INSTÁVEIS

Ref. TK05

DIN 338

HSSCo 5%



INOX



FUNDIÇÃO



PVC



Brocas Metal

Rosa



STEP CUT

Broca helicoidal 5% HSSCo de Alto Desempenho STEP CUT, corte escalonado.
NOVA Broca STEP CUT com geometria escalonada inovadora que facilita uma suave penetração. Trabalhe com conforto, rapidez e precisão em superfícies curvas, instáveis ou inclinadas. Maior precisão, devido à sua ponta centralizadora que evita o escorregamento no início da furação. A geometria STEP CUT com corte escalonado gera furos mais centralizados, redondos e precisos. O triplo plano de amarração ANTISLIP no cabo transmite a potência do berbequim de forma adequada. Permite fazer furos passantes em aço inoxidável, fundição, cobre, níquel, zinco, PVC e fibra de vidro.

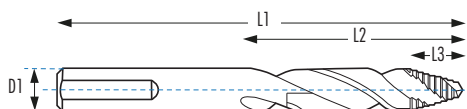

	D1 mm	L1 mm	L2 mm	L3 mm		TK05 €
TK050100	1,0	34	12	-	10	4,61
TK050150	1,5	40	18	-	10	4,76
TK050200	2,0	49	24	-	10	4,95
TK050250	2,5	57	30	1,6	10	5,77
TK050300	3,0	61	33	1,9	10	6,06
TK050350	3,5	70	39	2,1	10	7,23
TK050400	4,0	75	43	2,9	10	8,57
TK050450	4,5	80	47	3,3	10	9,41
TK050500	5,0	76	52	3,9	10	10,62
TK050550	5,5	93	57	4,6	10	11,25
TK050600	6,0	93	57	5,3	10	11,35
TK050650	6,5	101	63	5,8	10	13,24
TK050700	7,0	109	69	6,4	10	15,14
TK050750	7,5	109	69	6,9	10	17,71
TK050800	8,0	117	75	7,6	10	18,28
TK050850	8,5	117	75	8,2	10	21,70
TK050900	9,0	125	81	8,8	10	23,96
TK050950	9,5	125	81	9,3	10	25,85
TK051000	10,0	133	87	10,0	10	25,36
TK051050	10,5	133	87	10,7	10	27,61
TK051100	11,0	142	94	11,3	6	30,51
TK051150	11,5	142	94	12,0	6	33,18
TK051200	12,0	151	101	12,6	6	36,19
TK051250	12,5	151	101	13,8	6	38,51
TK051300	13,0	151	101	14,7	6	41,53



FERRAMENTAS STEP CUT FÁCIL PERFURAÇÃO EM SUPERFÍCIES CURVADAS E INSTÁVEIS

Brocas Metal

NEW

HSS

BROCAS MICROESCALONADAS HSS STEPCUT
NEW
STEP CUT

ESCALON 2 mm

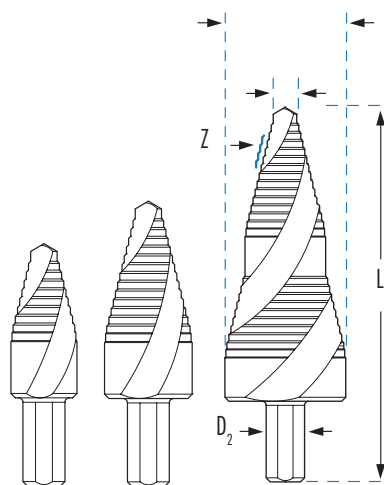

AV40BM37



AV40BM38



AV40BM36

	D mín. mm	D máx. mm	D2 mm	L1 mm	Z	Ø Z mm menor-maior	AV40BM	
							HSS	€
AV40BM37B	6,0	15,0	9,5	55	11	6-7-8-9-10-11-12-13-14-14,5-15		27,75
AV40BM38B	6,0	20,0	9,5	65	16	6-7-8-9-10-11-12-13-14-15-16-17-18-19-19,5-20		41,49
AV40BM36B	6,0	30,0	9,5	93	27	6-7-8-9-10-11-12-13-14-15-16-17-18-19-19,5-20-21-22-23-24-25-26-27-28-29-29,5-30		102,31

BROCA MACHO ESCAREADOR HSSCo STEP CUT

NEW

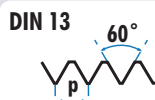

DIN 13

HSSCo
5%

BRILHANTE

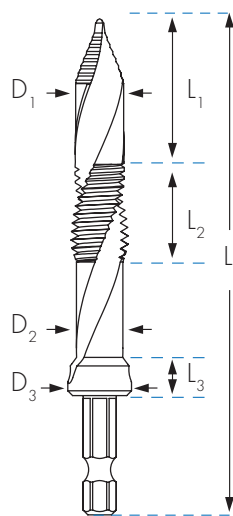
TOL
6H
D
CABO
FINO
STEP CUT

			L1 mm	L2 mm	L3 mm	L mm	D1 mm	D2 mm	D3 mm	MTKM	
										€	
M	3x0,50	D	7,5	6,0	6,0	52,0	2,5	2,2	7,3		28,21
M	4x0,70	D	10,0	8,4	6,0	56,4	3,3	3,0	7,3		28,21
M	5x0,80	D	13,0	9,5	6,0	63,5	4,2	3,7	7,3		29,44
M	6x1,00	D	15,0	12,0	6,0	68,0	5,0	4,5	7,3		30,66
M	8x1,25	D	20,0	15,0	6,0	81,0	6,8	6,3	9,4		42,38
M	10x1,50	D	25,0	18,0	6,0	89,0	8,5	8,0	11,4		51,14
M	12x1,75	D	30,0	21,0	8,0	104,0	10,3	9,8	13,4		56,36

BROCA QUADRADA PARA FURAR CANHOES DE SEGURANÇA

Ref. BCC06

MD

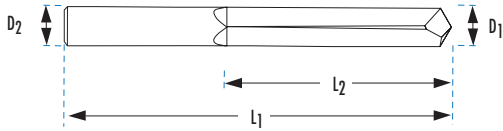

* Apta para furar os pivos "Anti-Drilling" de qualquer canhão de segurança.

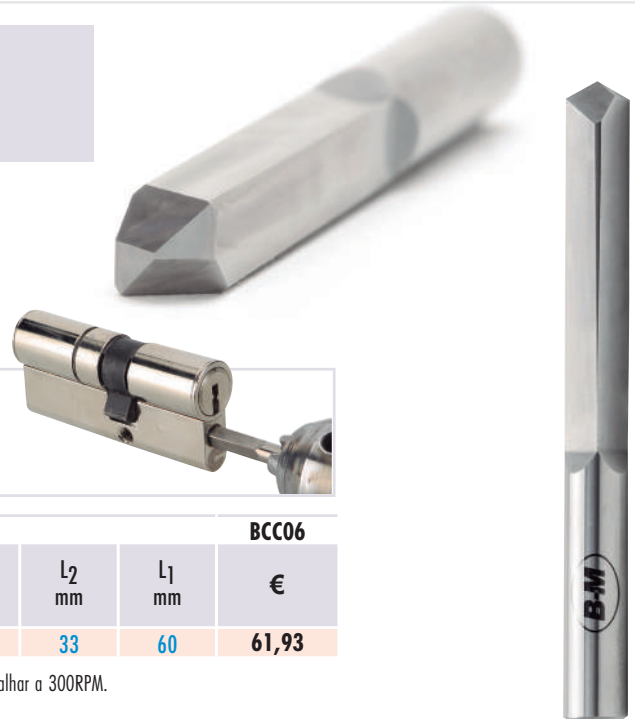

BCC06					€
	D1 mm	D2 mm	L2 mm	L1 mm	
BCC06X60MD	6	6	33	60	61,93

* Para furar os canhões com pivos "anti-drilling" trabalhar a 300RPM.

BROCA ANTI-FAÍSCA PARA TRABALHOS EM AMBIENTES EXPLOSIVOS (ATEX)

Ref. BACH

22 HRC

Cu-Be

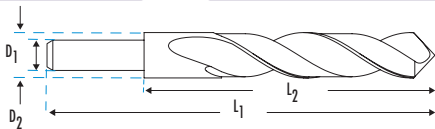

* Fabricada em cobre-berílio, conforme ao standar Q/ZBF-312.
 * Certificações e ficha de segurança disponíveis.
 * Apta para trabalhar em ambientes explosivos.

BACH					€
	D1 mm	D2 mm	L1 mm	L2 mm	
BACH0600	6,0	6,0	100	60	475,85
BACH0700	7,0	7,0	120	80	495,62
BACH0800	8,0	8,0	140	80	526,13
BACH0900	9,0	9,0	160	86	548,58
BACH1000	10,0	10,0	180	108	579,11
BACH1100	11,0	11,0	200	125	598,86
BACH1200	12,0	12,0	220	135	618,62
BACH1300	13,0	12,0	240	150	641,96
BACH1400	14,0	12,0	260	160	661,71
BACH1500	15,0	12,0	280	190	681,45
BACH1600	16,0	12,0	300	195	725,45
BACH1700	17,0	12,0	300	195	760,46
BACH1800	18,0	12,0	320	195	827,80
BACH1900	19,0	12,0	320	205	860,12
BACH2000	20,0	12,0	330	205	908,60

* Comprimentos especiais sob demanda.



Devido às suas características especiais de dureza e resistência (significativamente inferiores às que podem ser obtidas em ferramentas de aço), as ferramentas anti-faísca não podem ser garantidas contra qualquer deformação ou quebra. Apenas serão substituídas como garantia as brocas anti-faísca cuja dureza seja inferior a 35 HRC.

BROCA DELTABIT 3 NAVALHAS
3Z

Ref. BTT33

**DIN
338**
**HSSCo
5%**

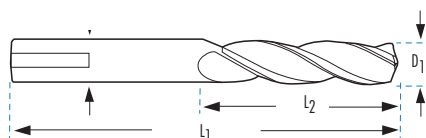
**TOL
H8**

- Maior precisão nos furos
- Buracos mais arredondados e alinhados
- Cabo com tripla face Anti-derrapante, maior aderência à bucha

BTT33

	D ₁ mm	L ₁ mm	L ₂ mm	€
BTT330300	3,0	61	33	2,63
BTT330330	3,3	65	36	3,40
BTT330350	3,5	70	39	3,40
BTT330400	4,0	75	43	3,99
BTT330420	4,2	75	43	4,92
BTT330450	4,5	80	47	4,92
BTT330500	5,0	86	52	5,62
BTT330550	5,5	93	57	6,98
BTT330600	6,0	93	57	8,06
BTT330650	6,5	101	63	9,27
BTT330680	6,8	109	69	10,67
BTT330700	7,0	109	69	10,67
BTT330750	7,5	109	69	12,17
BTT330800	8,0	117	75	14,55
BTT330850	8,5	117	75	16,19
BTT330900	9,0	125	81	18,78
BTT330950	9,5	125	81	20,45
BTT331000	10,0	133	87	23,04
BTT331020	10,2	133	87	25,66
BTT331050	10,5	133	87	25,66
BTT331100	11,0	142	94	29,54
BTT331150	11,5	142	94	31,95
BTT331200	12,0	151	101	36,96
BTT331250	12,5	151	101	39,55
BTT331300	13,0	151	101	42,14



BROCA ESPECIAL PARA FURAÇÃO DE HARDOX E CHAPA ANTI-DESGASTE

Ref. BHA

3xD

DIN 338

HSSCo 8%



135°

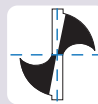

HARDTOP

HARDOX 400

HARDOX 450

HARDOX 600

Geometria especial da ponta, com Split Point e dupla faceta recortada.

O revestimento HARDTOP melhora o deslizamento das limalhas e evita a aderência na aresta de corte.

Melhora a resistência mecânica e protege a broca reduzindo o coeficiente de atrito.

O seu canal de baixa profundidade gera um núcleo reforçado que facilita a estabilidade da usinagem.

Máximo rendimento em materiais de alta resistência.

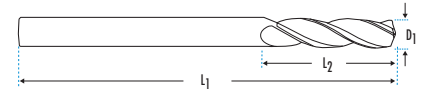

	BHA			
	D1 mm	L1 mm	L2 mm	€
BHA0100	1,0	34	6	12,02
BHA0150	1,5	40	9	12,02
BHA0200	2,0	49	12	12,49
BHA0250	2,5	57	14	12,73
BHA0300	3,0	61	16	12,84
BHA0320	3,2	65	18	13,67
BHA0330	3,3	65	18	13,67
BHA0350	3,5	70	20	13,67
BHA0400	4,0	75	22	14,52
BHA0420	4,2	75	22	18,93
BHA0450	4,5	80	24	18,93
BHA0500	5,0	86	26	17,94
BHA0550	5,5	93	28	24,24
BHA0600	6,0	93	28	22,71
BHA0650	6,5	101	31	26,18
BHA0680	6,8	109	34	30,41
BHA0700	7,0	109	34	28,03
BHA0750	7,5	109	34	33,57
BHA0800	8,0	117	37	36,50
BHA0850	8,5	117	37	36,50
BHA0900	9,0	125	40	43,70
BHA0950	9,5	125	40	49,33
BHA1000	10,0	133	43	47,85
BHA1020	10,2	133	43	55,67
BHA1050	10,5	133	43	60,13
BHA1100	11,0	142	47	62,57
BHA1150	11,5	142	47	70,45
BHA1200	12,0	151	51	65,62
BHA1250	12,5	151	51	86,20
BHA1300	13,0	151	51	93,94



Ângulo de ponta de 135°.
Oferece excelente centralização.

CHANFRO GUIA ESTREITO
Redução total do atrito fora da zona de corte.

HARDTOP

Aumenta o deslizamento da limanha na aresta de corte, evitando a sua aderência e facilitando o deslizamento rápido ao longo do canal de evacuação.

HSSCo 8%

AÇO M42 HSSCo 8%
Permite usinar materiais de alta resistência e dureza em altas temperaturas.

Norma dimensional DIN 338

vc (m/min)	BHA			
	Hardox® HiTuf	Hardox® 400	Hardox® 450	Hardox® 600
	11	8	6	4
Ø	f(mm/rev.)	f(mm/rev.)	f(mm/rev.)	f(mm/rev.)
2,5	0,035/1400	0,025/1000	0,015/770	0,005/500
3	0,04/1200	0,03/850	0,02/640	0,01/430
4	0,05/900	0,04/650	0,03/480	0,02/320
5	0,06/700	0,05/510	0,04/400	0,03/255
6	0,07/590	0,06/430	0,05/320	0,04/220
7	0,08/500	0,07/370	0,06/280	0,05/190
8	0,09/440	0,08/320	0,07/240	0,06/160
10	0,11/350	0,10/260	0,09/200	0,08/130
13	0,14/270	0,13/200	0,12/150	0,1/100

BROCAS HELICOIDAIS COM CABO CILINDRICO, SERIE LONGA E EXTRA-CURTA

Brocas Metal

Rosa

**DIN
340**

**DIN
1897**

		BC4	BC47	BC40	BC44	BC48	BC78										
MATERIAL		HSS	HSSCo 5%	HSS	HSSCo 5%	HSSCo 5%	PMD		BC3	BC31	BC37	BC33	BC35	BC77	BC43	BC17	BC38
AFIAÇÃO																	
ÂNGULO PONTA		118°	135°	118°	135°	135°	118°		135°	135°	135°	135°	118°	118°	135°	135°	135°
HÉLICE																	
ACABAMENTO		OX	DOURADO	TiN	BRILHANTE	TiAIN	BRILHANTE		OX	DOURADO	TiN	BRILHANTE	TiAIN	BRILHANTE	BRILHANTE	OX	DOURADO
APLICAÇÃO																	
Ø mm	L1 x L2	€	€	€	€	€	€	L1 x L2	€	€	€	€	€	€	€	€	€
0,50	32x13	6,94						23x5									
0,60	37x17	5,64						23x5									14,86
0,70	42x21	5,64						23x5									14,86
0,80	47x23	5,62						23x5									14,86
0,90	51x25	5,62						23x5									
1,00	56x33	5,68						26x6	1,44	2,47	3,00	4,18			10,39		
1,10	56x33	5,52						26x6	1,69								
1,20	60x37	5,52						26x6	1,69								
1,25	65x41	5,71						30x8	1,26	2,88	2,81						
1,30	65x41	5,52						30x8	1,69								
1,40	70x45	5,52						30x9	1,69								
1,50	70x45	4,06		5,30				30x9	1,26	2,34	2,81	5,10			11,90		
1,60	76x50	5,52			10,48			34x10	1,44	3,03	3,00						
1,70	76x50	5,51			10,52			36x11	1,67								
1,75	80x53	4,56						36x11	1,44	2,88	3,00						
1,80	80x53	4,40			9,96			36x11	1,44	3,03	3,00						
1,90	80x53	4,40			10,52			38x12	1,50								
2,00	85x56	2,90	5,84	4,32	9,27	11,69	36,36	38x12	1,24	2,34	2,79	4,48	5,38	21,09	9,55	2,35	
2,10	85x56	4,12			8,95			38x12	1,35	2,86	2,89				11,23		
2,20	90x59	4,12			9,57			40x13	1,35	2,86	2,89				11,23		
2,25	90x59	3,30						40x13	1,15	2,82	2,71						
2,30	90x59	3,98			9,25			40x13	1,35	2,86	2,89				11,23		
2,40	95x62	3,98			11,79			43x14	1,35	2,86	2,89				11,23		
2,50	95x62	3,01	5,45	4,27	8,69	10,86	36,01	43x14	1,05	1,98	2,61	3,92	5,04	21,09	10,59	2,34	
2,60	95x62	3,99			10,82			43x14	1,28	2,31	2,83			21,60	11,23		
2,70	100x66	3,99			9,73			46x16	1,28	2,32	2,83				14,75		

DIN 340		DIN 1897															
		BC4	BC47	BC40	BC44	BC48	BC78										
MATERIAL		HSS	HSSCo 5%	HSS	HSSCo 5%	HSSCo 5%	PMD										
AFIAÇÃO																	
ÂNGULO PONTA		118°	135°	118°	135°	135°	118°										
HÉLICE																	
ACABAMENTO		OX	DOURADO	TiN	BRILHANTE	TiAlN	BRILHANTE										
APLICAÇÃO																	
Ø mm	L1 x L2	€	€	€	€	€	€	L1 x L2	€	€	€	€	€	€	€	€	€
2,75	100x66	4,10						46x16	1,10	2,39	2,66						
2,80	100x66	3,99			10,82			46x16	1,29	2,32	2,84				14,75		
2,90	100x66	3,99			10,80			46x16	1,29	2,32	2,84				14,75		
3,00	100x66	2,78	5,45	4,10	8,64	10,95	32,34	46x16	1,10	1,98	2,66	3,76	4,89	19,15	13,39	2,05	
3,10	106x69	3,09	6,16	4,78	9,91	12,85		49x18	1,19	2,07	3,04	4,19			14,99	2,05	
3,20	106x69	3,09	6,17		9,94	12,77		49x18	1,19	2,07	3,04	4,19			14,99	2,05	
3,25	106x69	3,09	6,16	4,78				49x18	1,19	2,07	3,04			25,20		2,05	2,95
3,30	106x69	3,09			9,96	12,74		49x18	1,21	2,07	3,05	4,19	6,05		14,99	2,05	
3,40	112x73	4,00			12,61			52x20	1,35	2,55	3,19	4,06		25,20	16,12	2,30	
3,50	112x73	2,93	6,43	4,57	10,27	13,13	30,97	52x20	1,19	2,07	3,04	4,43	6,02	19,15	15,03	2,30	3,65
3,60	112x73	4,00			11,97			52x20	1,50	2,55	3,35	5,10			17,73		
3,70	112x73	4,00			12,41			52x20	1,50	2,55	3,35	5,10	6,73		17,73		
3,75	112x73	4,13	7,33	5,80				52x20	1,32	2,64	3,17					2,62	
3,80	119x78	4,96			14,91			55x22	1,50	2,55	3,35	5,11			19,07	2,52	
3,90	119x78	4,96	7,32		13,17			55x22	1,50	2,55	3,35	5,11			19,07		
4,00	119x78	3,17	6,63	4,84	10,54	13,47	32,09	55x22	1,32	2,34	3,17	4,90	6,27	19,11	17,82	2,33	3,74
4,10	119x78	4,14	7,44		11,69	14,50		55x22	1,57	2,79	3,42	5,34			20,02	2,52	
4,20	119x78	4,14	7,44		11,71	14,61		55x22	1,57	2,79	3,42	5,40	6,87	22,40	20,02	2,52	
4,25	119x78	4,14	7,30	5,80				55x22	1,57	2,79	3,42					2,52	
4,30	126x82	5,38		5,80	13,04	15,81		58x24	1,79	3,18	3,65	5,73			21,24		
4,40	126x82	5,38			13,58			58x24	1,79	3,18	3,65	5,92			21,24		
4,50	126x82	3,78	8,15	5,49	12,93	15,92	32,80	58x24	1,57	2,79	3,42	5,50	6,97	20,93	20,62	2,62	
4,60	126x82	5,34			17,46			58x24	2,03	3,34	3,88	6,60			21,24		
4,70	126x82	5,34			12,96			58x24	2,03	3,34	3,88	6,34			22,76		
4,75	126x82	5,58	8,18	7,25				58x24	1,74	3,10	3,59					4,21	
4,80	132x87	6,19	8,32		13,58			62x26	2,03	3,34	3,88	6,46			22,76		
4,90	132x87	6,19			18,83			62x26	2,03	3,34	3,88	6,60			22,76		
5,00	132x87	4,07	8,15	5,72	13,12	15,92	33,10	62x26	1,74	3,09	3,59	6,00	7,34	22,63	21,82	2,99	4,77
5,10	132x87	6,19	8,98		15,23	18,08		62x26	2,22	3,79	4,08	6,91		28,79	22,76	4,05	
5,20	132x87	6,19			15,27		35,91	62x26	2,21	3,76	4,07	7,12			29,48	4,05	
5,25	132x87	6,46	9,67	8,09				62x26	1,93	3,44	3,78					4,21	
5,30	132x87	6,74			15,86	18,72		62x26	2,24	3,76	4,09	7,29			29,48		
5,40	139x91	6,74			22,10			66x28	2,24	3,76	4,09	7,51			29,48		
5,50	139x91	5,36	11,20	6,99	17,71	20,56	35,92	66x28	1,93	3,44	3,78	7,13	8,55	27,05	28,61	3,61	
5,60	139x91	6,75			18,19			66x28	2,55	4,01	4,41	7,89			31,32		
5,70	139x91	6,75		8,64	14,45			66x28	2,58	4,01	4,43	8,15		30,05	31,32		
5,75	139x91	7,01	11,27	8,64				66x28	2,16	4,16	4,01					5,01	
5,80	139x91	7,41	11,26		18,54			66x28	2,55	4,01	4,41	7,90			31,32		
5,90	139x91	7,41			18,88			66x28	2,58	4,01	4,43	7,88			31,32		
6,00	139x91	4,94	11,20	6,56	17,79	20,72	35,89	66x28	2,20	3,91	4,06	7,61	8,97	29,57	31,87	4,07	
6,10	148x97	7,41			24,88			70x31	3,01	5,06	5,82	9,29		30,83	39,00		
6,20	148x97	7,41			23,24			70x31	3,01	5,06	5,82	9,15			39,00		
6,25	148x97	7,71		10,11				70x31	2,62	5,22	5,42						
6,30	148x97	7,50						70x31	3,01	5,06	5,82	9,50			39,00		
6,40	148x97	7,50						70x31	3,01	5,03	5,82	9,51			39,00		
6,50	148x97	6,37	12,86	10,74	20,53	28,07	38,63	70x31	2,61	4,67	7,56	9,17	13,68	30,91	37,50		
6,60	148x97	7,50						74x34	3,50	6,31	8,47	10,69			45,88		
6,70	148x97	7,50			19,29			74x34	3,50	6,31	8,47	10,69			45,88		
6,75	156x102	7,81	14,81	12,12				74x34	2,98	6,51	7,93						
6,80	156x102	7,77			23,84	31,53		74x34	3,04	6,49	8,00	10,51	16,88	39,00	45,88		
6,90	156x102	7,96						74x34	3,34					34,39	45,88		

BROCAS HELICOIDAIS COM CABO CILINDRICO, SERIE LONGA E EXTRA-CURTA

Brocas Metal

Rosa

**DIN
340**

**DIN
1897**

		BC4	BC47	BC40	BC44	BC48	BC78										
		HSS	HSSCo 5%	HSS	HSSCo 5%	HSSCo 5%	PMD										
		118°	135°	118°	135°	135°	118°										
		30° "N"	30° "N"	30° "N"	38° "5"	38° "5"	30° "N"										
		OX	DOURADO	TiN	BRILHANTE	TiAlN	BRILHANTE										
		70 Kg/mm ²	120 Kg/mm ²	PRODUÇÃO	INOX	INOX	FUNDIÇÃO										
		OX	DOURADO	TiN	BRILHANTE	TiAlN	BRILHANTE	BRILHANTE	BRILHANTE	OX	DOURADO						
		70 Kg/mm ²	120 Kg/mm ²	PRODUÇÃO	INOX	INOX Plus	FUNDIÇÃO	ALTA PRODUÇÃO	70 Kg/mm ²	120 Kg/mm ²							
Ø mm	L1 x L2	€	€	€	€	€	€	L1 x L2	€	€	€	€	€	€	€	€	
7,00	156x102	7,41	15,01	11,86	23,94	32,01	38,63	74x34	3,04	5,35	8,00	10,49	14,71	33,96	44,07	5,30	
7,10	156x102	7,96						74x34							55,89		
7,20	156x102	7,96			29,09			74x34	3,93						54,82		
7,25	156x102	8,30						74x34	3,44	6,97	8,39						
7,30	156x102	8,14			29,08			74x34		6,96					55,89		
7,40	156x102	8,14						74x34							55,89		
7,50	156x102	7,90	15,94	12,29	25,52	33,48	44,01	74x34	3,44	6,51	8,39	12,50	17,41	35,69	49,44		
7,60	165x109	8,14						79x37		7,54					61,87		
7,70	165x109	8,14						79x37		7,54					63,08		
7,75	165x109	8,46		11,92				79x37	3,79	7,54	8,76						
7,80	165x109	9,11			35,08			79x37	4,34	7,78	9,29	13,61	26,38		61,87		
7,90	165x109	9,11						79x37		7,78					61,87		
8,00	165x109	8,72	17,66	13,24	28,34	36,06	44,01	79x37	3,75	6,74	8,70	13,09	17,20	38,07	57,98	6,54	
8,10	165x109	9,11						79x37						42,34	75,44		
8,20	165x109	9,11			31,87			79x37							76,92		
8,25	165x109	9,46						79x37	4,51	8,88	9,47						
8,30	165x109	13,88						79x37							76,92		
8,40	165x109	14,00						79x37							76,92		
8,50	165x109	9,80	19,79	14,98	31,35	40,93	55,69	79x37	4,51	7,97	9,47	15,24	20,38	41,78	74,35		
8,60	175x115	14,00						84x40		9,65				43,38	81,86		
8,70	175x115	14,00						84x40							83,45		
8,75	175x115	14,54		15,30				84x40	4,92	9,64	9,89						
8,80	175x115	14,30			34,04			84x40							81,86		
8,90	175x115	14,30						84x40							83,45		
9,00	175x115	10,62	21,43	15,75	34,42	43,63	48,67	84x40	4,88	8,76	10,67	16,56	21,62	44,52	70,20		

BROCAS HELICOIDAIS COM CABO CILINDRICO, SERIE LONGA E EXTRA-CURTA

Brocas Metal

Rosa

DIN
340DIN
1897

		BC4	BC47	BC40	BC44	BC48	BC78			BC3	BC31	BC37	BC33	BC35	BC77	BC43	BC17	BC38
MATERIAL		HSS	HSSCo 5%	HSS	HSSCo 5%	HSSCo 5%	PMD		HSS	HSSCo 5%	HSS	HSSCo 5%	HSSCo 5%	PMD	MD	HSS	HSSCo 5%	
AFIAÇÃO																		
ÂNGULO PONTA		118°	135°	118°	135°	135°	118°		135°	135°	135°	135°	118°	118°	135°	135°	135°	
HÉLICE		30° "N"	30° "N"	30° "N"	38° "5"	38° "5"	30° "N"		30° "N"	30° "N"	30° "N"	38° "5"	38° "5"	30° "N"	35° "N"	30° "N"	30° "N"	
ACABAMENTO		OX	DOURADO	TiN	BRILHANTE	TiAlN	BRILHANTE		OX	DOURADO	TiN	BRILHANTE	TiAlN	BRILHANTE	BRILHANTE	OX	DOURADO	
APLICAÇÃO																		
Ø mm	L1 x L2	€	€	€	€	€	€	L1 x L2	€	€	€	€	€	€	€	€	€	€
14,00	214x140	28,69					100,99	107x54	15,23	27,06	30,11	50,06		95,68	194,64			
14,25	220x144	51,70																
14,50	220x144	33,56						111x56	17,53	37,54	32,41	63,35			318,61			
14,75	220x144	51,70																
15,00	220x144	32,49					109,79	111x56	20,05	38,12	34,94	59,96		118,22	209,10			
15,25	227x149	58,32																
15,50	227x149	48,20						115x58	24,15	44,08	39,04	69,31			383,52			
15,75	227x149	58,35																
16,00	227x149	37,81					135,85	115x58	24,15	45,71	39,04	70,55		137,13	259,90			
16,25	235x154	64,38																
16,50	235x154	44,74						119x60	28,41	52,28	48,25							
16,75	235x154	64,38																
17,00	235x154	44,94					173,13	119x60	28,41	52,28	48,25							
17,25	241x158	74,02																
17,50	241x158	66,40						123x62	31,64	57,91	51,48							
17,75	241x158	86,47																
18,00	241x158	46,84					181,15	123x62	31,64	63,09	54,79							
18,25	247x162	90,41																
18,50	247x162	72,54						127x64	35,26	69,66	58,40							
18,75	247x162	125,91																
19,00	247x162	58,74						127x64	35,26	69,66	58,40							
19,25	254x166	130,96																
19,50	254x166	112,95						131x66	42,26	77,26	68,71							
19,75	254x166	127,56																
20,00	254x166	65,91					251,29	131x66	42,26	82,79	68,71				653,21			

BROCAS HELICOIDAIS COM CABO CILINDRICO SERIE EXTRA-LONGA

DIN 1869 I/II/III



		BC8	BC88
MATERIAL		HSS	HSSCo 5%
AFIAÇÃO			
ÂNGULO PONTA		118°	135°
HÉLICE		30° "N"	38° "S"
ACABAMENTO		OX	BRILHANTE
APLICAÇÃO		70 Kg/mm²	INOX
Ø mm	L1 x L2	€	€
0,50	50x25	13,35	
0,60	60x30	13,35	
0,70	60x30	13,49	
0,70	80x50	15,30	
0,80	60x30	13,76	
0,80	80x50	15,56	
0,80	120x60	19,94	
1,00	80x50	16,10	
1,00	100x70	17,46	
1,00	150x75	18,91	
1,50	100x70	12,73	
1,50	140x100	14,10	
2,00	100x70	12,50	
2,00	125x85	13,54	18,53
2,00	150x100	16,74	
2,00	160x125		29,90
2,00	200x135		35,67
2,25	135x90		23,59
2,50	140x95	14,27	18,53
2,50	180x130		33,31
2,50	225x150		39,34
2,75	150x100		25,85
3,00	150x100	14,66	21,05
3,00	190x130	17,02	25,88
3,00	240x160		42,88
3,25	155x105		25,85
3,25	200x135		31,92
3,50	165x115	16,64	21,34
3,50	210x145	19,12	27,41
3,50	265x180	27,25	37,18
3,75	165x115		29,94
3,75	210x145		31,92
3,75	265x180		42,15
4,00	175x120	16,48	21,34
4,00	220x150	19,58	27,41
4,00	280x190	27,91	37,18
4,25	175x120		31,71
4,25	220x150	34,09	40,99
4,25	280x190		51,29
4,50	185x125	18,45	24,97
4,50	235x160	22,96	32,57
4,50	295x220	32,81	46,28

		BC8	BC88
Ø mm	L1 x L2	€	€
4,75	185x125		32,65
4,75	235x160		40,99
4,75	295x200		51,29
5,00	195x135	19,34	33,53
5,00	245x170	24,68	37,90
5,00	315x210	30,41	43,73
5,25	195x135		33,10
5,25	245x170		45,78
5,25	315x210		54,86
5,50	205x140	23,00	26,74
5,50	260x180	32,77	40,45
5,50	330x225	38,00	49,73
5,75	205x140	27,77	33,10
5,75	260x180	38,41	45,78
5,75	330x225	47,03	55,56
6,00	205x140	22,97	26,73
6,00	260x180	32,96	40,45
6,00	330x225	37,85	49,89
6,25	215x150		38,80
6,25	275x190		47,91
6,25	350x235		61,84
6,50	215x150	27,24	33,11
6,50	275x190	35,26	44,64
6,50	350x235	43,92	56,97
6,75	225x155		42,15
6,75	290x200		55,32
6,75	370x250		78,43
7,00	225x155	28,97	41,10
7,00	290x200	40,31	49,89
7,00	370x250	54,48	73,48
7,25	225x155		53,68
7,25	290x200		66,19
7,25	370x250		88,43
7,50	225x155	32,58	45,34
7,50	290x200	43,45	59,44
7,50	370x250	63,26	83,44
7,75	240x165		55,32
7,75	305x210		66,19
7,75	390x265		97,81
8,00	240x165	36,02	46,28
8,00	305x210	49,94	57,89
8,00	390x265	65,08	85,71
8,25	240x165		72,55
8,25	305x210		96,32
8,25	390x265		117,00
8,50	240x165	48,97	62,78
8,50	305x210	66,86	87,54
8,50	390x265	91,28	107,21
8,75	240x165		77,52
8,75	320x220		96,32
8,75	410x280		123,16

		BC8	BC88
Ø mm	L1 x L2	€	€
9,00	250x175	46,80	66,98
9,00	320x220	61,47	84,18
9,00	410x280	90,74	113,83
9,25	250x175		90,65
9,25	320x220		115,60
9,25	410x280		144,56
9,50	250x175	54,88	77,53
9,50	320x220	75,86	100,65
9,50	410x280	101,97	133,79
9,75	265x185		92,50
9,75	340x235		120,45
9,75	430x295		155,24
10,00	265x185	54,61	70,28
10,00	340x235	71,02	92,54
10,00	430x295	98,66	130,43
10,25	265x185		137,06
10,25	340x235		148,59
10,25	430x295		158,01
10,50	265x185	100,62	118,82
10,50	340x235	109,05	128,80
10,50	430x295	115,98	136,97
10,75	280x195		137,06
10,75	365x250		148,59
10,75	455x310		158,01
11,00	280x195	68,90	89,10
11,00	365x250	97,91	115,65
11,00	455x310	114,62	135,35
11,25	280x195		127,66
11,25	365x250		171,38
11,25	455x310		177,03
11,50	280x195	93,68	110,67
11,50	365x250	125,78	148,58
11,50	455x310	129,96	153,48
11,75	280x195		127,66
11,75	365x250		171,38
11,75	455x310		177,03
12,00	295x205	90,64	100,65
12,00	375x260	110,47	130,43
12,00	480x330	134,42	158,73
12,25	295x205		148,59
12,25	375x260		166,40
12,25	480x330		201,96
12,50	295x205	109,05	128,80
12,50	375x260	122,12	144,23
12,50	480x330	148,22	175,05
12,75	295x205		148,59
12,75	375x260		166,40
12,75	480x330		201,96
13,00	295x205	109,05	128,80
13,00	375x260	125,80	148,58
13,00	480x330	149,62	176,70

* Comprimentos especiais sob demanda.

BROCA HELICOIDAL PARA AERONAUTICA, SERIE EXTRA-LONGA

Brocas Metal

Rosa

Ref. BC08

HSS

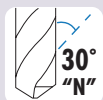
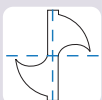

AIRCRAFT

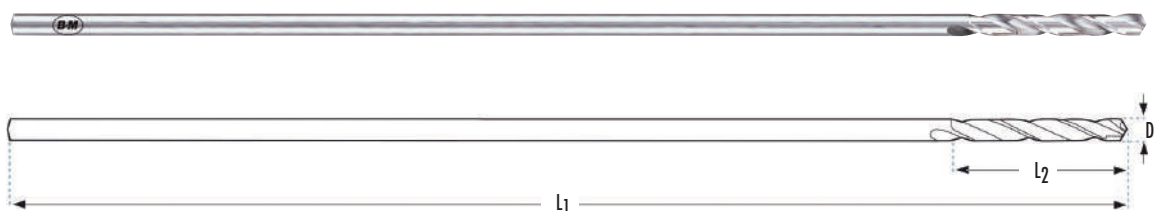

150 mm

				BC08
	D ₁ mm	L ₁ mm	L ₂ mm	€
BC080225150	2,25	150	25	14,82
BC080250150	2,50	150	25	14,31
BC080320150	3,20	150	26	14,28
BC080325150	3,25	150	36	14,07
BC080400150	4,00	150	43	14,55

300 mm

				BC08
	D ₁ mm	L ₁ mm	L ₂ mm	€
BC080225300	2,25	300	25	15,74
BC080250300	2,50	300	25	14,88
BC080320300	3,20	300	26	14,91
BC080325300	3,25	300	36	14,86
BC080400300	4,00	300	43	16,63

* Outros diâmetros disponíveis sob demanda.

BROCA DE METAL DURO HELICOIDAL PARA AERONÁUTICA, SÉRIE EXTRA-LONGA

Ref. BC08PMD

PMD

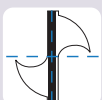
AIRCRAFT
MD

85°

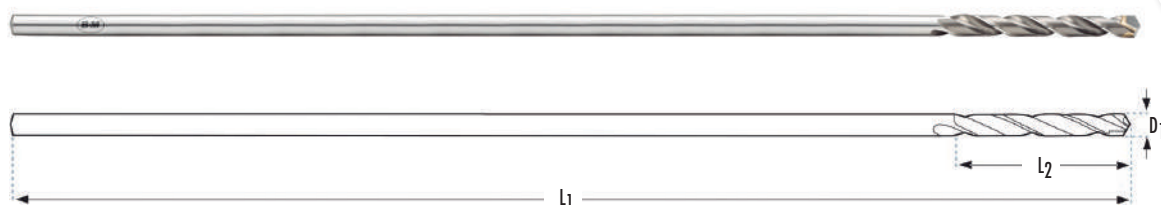

* Disponibilidade série Aircraft MD. Fabricação de medidas especiais sob demanda.

BROCAS DE CENTRAR

Ref. BC10
Ref. BC10Co
Ref. BC65

Ref. BC10I
Ref. BC10MD
Ref. BC10W

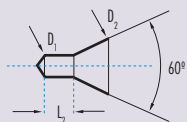

DIN
333A



DIN
333W

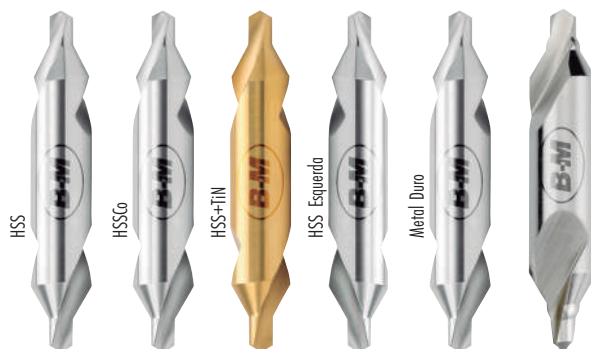
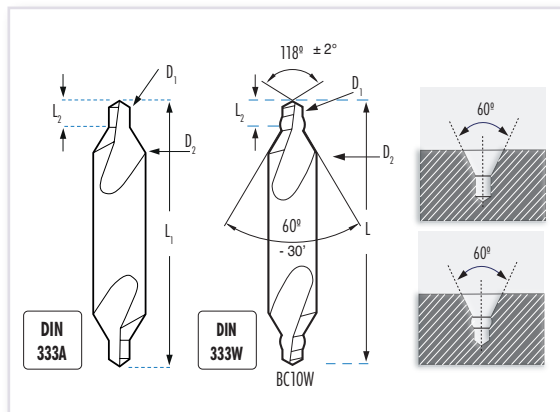

D1 x D2 mm	L1 x L2 mm	BC10	BC10Co	BC65	BC10I	BC10MD	BCW10
		HSS	HSSCo 5%	TiN	HSS	MD	HSS
		€	€	€	€	€	€
0,50 x 3,00	31 x 1	14,42		19,88			17,30
0,50 x 3,15*	25 x 1	8,47	9,21	14,10			10,16
0,63 x 3,15*	25 x 1	8,47		14,10		65,83	
0,80 x 3,15*	25 x 1	8,32	9,21	13,97			9,99
1,00 x 3,15	31 x 1	6,16	9,21	11,88		62,70	7,39
1,25 x 3,15	33 x 1	6,16	9,21	11,88		62,70	7,39
0,75 x 3,50	35 x 1	8,99	9,21	14,63			
1,00 x 4,00	35 x 1	7,74	9,21	13,41		70,29	9,28
1,25 x 4,00	35 x 1	6,54		12,69			7,85
1,50 x 5,00	40 x 2	7,45	9,91	14,32		71,71	8,94
1,60 x 4,00	37 x 2	6,16	9,21	12,34	11,12	66,96	7,39
1,60 x 5,00	40 x 2	6,51		13,40			7,81
2,00 x 5,00	42 x 2	6,62	9,91	13,51	11,95	76,30	7,95
2,00 x 6,00	45 x 2	7,45	10,44	14,79		81,35	8,94
2,00 x 6,30	45 x 2	6,68		14,54	12,68		8,84
2,50 x 6,30	47 x 3	7,36	11,01	14,72	13,28	86,94	8,84
2,50 x 8,00	50 x 3	8,12	11,01	15,43	14,66	102,42	9,74
3,00 x 8,00	50 x 3	8,13	11,61	15,46		102,42	9,75
3,15 x 8,00	52 x 4	8,10	12,10	15,43	14,63	97,55	9,71
3,00 x 10,00	55 x 4	10,57	16,05	18,34		121,54	12,68
3,15 x 10,00	56 x 4	9,58		20,10	17,28		11,49
4,00 x 10,00	59 x 5	11,24	16,05	20,82	20,29	121,54	13,48
4,00 x 12,00	63 x 5	18,16	25,30	26,87			21,79
4,00 x 12,50	63 x 5	13,08		26,87	23,63		21,79
5,00 x 12,00	63 x 5	18,16	25,30	26,87		196,88	21,79
5,00 x 12,50	66 x 6	19,70	26,44	28,49	35,59	202,99	23,64
5,00 x 14,00	69 x 6	31,21	34,94	40,82			37,45
5,00 x 16,00	71 x 6	31,21		37,15	56,36		37,45
6,30 x 16,00	74 x 8	26,96	37,84	37,15		324,26	32,35
6,30 x 18,00	77 x 8	47,51		60,50			57,02
6,30 x 20,00	80 x 8	47,51		60,50			61,77
8,00 x 20,00	81 x 27	52,04	103,55	75,17			62,44
8,00 x 25,00	100 x 10	113,49		144,34			
10,00 x 25,00	100 x 31	80,74	113,97	112,55			96,89
10,00 x 31,50	125 x 12	239,51		288,78			
12,50 x 31,50	125 x 33	192,06	249,61	243,72			



BROCAS DE CENTRAR

Brocas Metal

Rosa

 Ref. BC64
 Ref. BC68

**DIN
333A**
SERIE LONGA

Ref. BC62

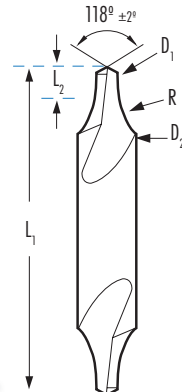
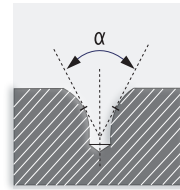
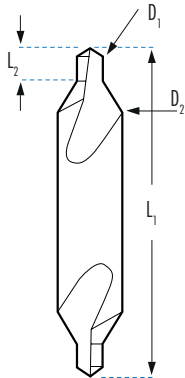
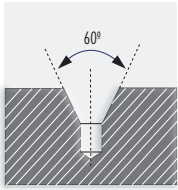
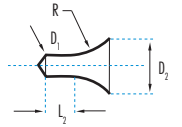
**DIN
333R**

D1 x D2 mm	L1 x L2 mm	BC64		BC68	
		HSS €	TiN €	HSS €	TiN €
1,00 x 4,00	60 x 1	21,10	32,00		
1,00 x 4,00	120 x 1	42,62	81,40		
1,50 x 5,00	60 x 2	21,53	32,41		
1,50 x 5,00	120 x 2	43,45	72,02		
2,00 x 5,00	200 x 2	88,86	159,07		
2,00 x 6,00	80 x 2	22,42	35,20		
2,00 x 6,00	120 x 2	33,96	71,18		
2,50 x 6,30	200 x 2	87,27	157,48		
2,50 x 8,00	80 x 3	27,28	45,77		
2,50 x 8,00	120 x 3	41,31	84,37		
3,00 x 8,00	80 x 4	27,28	45,77		
3,00 x 8,00	120 x 4	41,31	84,37		
3,15 x 8,00	200 x 4	82,50	152,72		
3,00 x 10,00	100 x 4	35,23	57,58		
3,00 x 10,00	120 x 4	42,67	95,50		
4,00 x 10,00	100 x 5	35,27	57,58		
4,00 x 10,00	120 x 5	42,73	95,50		
4,00 x 10,00	200 x 5	90,44	160,66		
4,00 x 12,00	100 x 5	47,50	85,96		
4,00 x 12,00	120 x 5	57,54	121,58		
5,00 x 14,00	120 x 6	80,57	146,54		

D1 x D2 mm	L1 x L2 mm	BC62		BC62MDI	
		HSS €	MD €	HSS €	MD €
0,50 x 3,00	31 x 2,3	10,12			
0,50 x 3,15	25 x 2,3	6,73	46,26		
0,80 x 3,15	25 x 2,6	6,73			
1,00 x 3,15	31 x 3,0	6,73	48,27		
1,25 x 3,15	31 x 3,3	6,73	48,27		
0,50 x 3,50	35 x 2,7	10,12			
0,75 x 3,50	35 x 2,8	6,73			
1,00 x 4,00	35 x 3,3	6,73			
1,25 x 4,00	35 x 3,7	6,73			
1,60 x 4,00	37 x 4,0	6,73	52,29		
1,50 x 5,00	40 x 4,5	7,36			
1,60 x 5,00	40 x 4,5	7,59			
2,00 x 5,00	42 x 5,0	7,32	62,34		
2,00 x 6,00	45 x 5,4	8,20			
2,00 x 6,30	45 x 6,0	8,49			
2,50 x 6,30	47 x 6,0	8,14	74,41		
2,50 x 8,00	50 x 7,0	8,94			
3,00 x 8,00	50 x 8,0	8,94			
3,15 x 8,00	52 x 8,0	8,94	90,50		
3,00 x 10,00	55 x 8,9	11,64			
3,15 x 10,00	56 x 9,0	11,64			
4,00 x 10,00	56 x 10,0	11,64	123,88		
4,00 x 12,00	63 x 10,7	18,39			
5,00 x 12,00	63 x 11,4	18,39			
4,00 x 12,50	63 x 11,0	19,41			
5,00 x 12,50	66 x 13,0	19,46	197,09		
5,00 x 14,00	69 x 12,8	25,09			
5,00 x 16,00	71 x 15,0	27,61			
6,30 x 16,00	74 x 17,0	27,95			
6,00 x 18,00	77 x 16,6	41,57			
6,30 x 20,00	80 x 19,0	49,55			
8,00 x 20,00	80 x 21,0	53,11			
10,00 x 25,00	100 x 26,0	87,98			
12,50 x 31,50	125 x 33,0	200,70			

BROCAS DE CENTRAR

Ref. BC63

DIN 333B

HSS

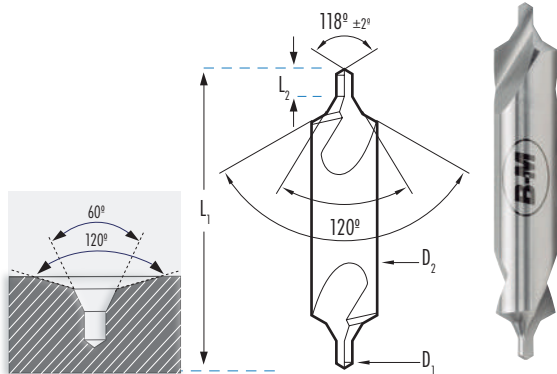
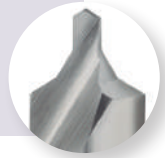

BC63

D1 x D2 mm	L1 x L2 mm	€
0,50 x 3,00	31,00 x 0,6	12,59
0,75 x 4,00	35,00 x 1,0	11,28
1,00 x 4,00	37,50 x 1,60	11,28
1,25 x 5,00	42,00 x 1,90	11,28
1,50 x 5,00	40,00 x 2,00	12,05
1,00 x 6,00	45,00 x 1,30	12,05
2,00 x 6,00	45,00 x 2,50	12,05
1,60 x 6,30	47,00 x 2,40	11,28
1,50 x 8,00	50,00 x 2,00	12,64
2,00 x 8,00	52,00 x 2,90	11,83
2,50 x 8,00	50,00 x 3,10	13,75
3,00 x 8,00	50,00 x 3,90	14,14
2,00 x 10,00	55,00 x 2,50	14,42
2,50 x 10,00	59,00 x 3,60	13,69
3,00 x 10,00	55,00 x 3,90	16,35
4,00 x 10,00	55,00 x 5,00	16,46
3,15 x 11,20	63,00 x 4,40	15,82
2,50 x 12,00	63,00 x 3,10	21,27
4,00 x 12,00	63,00 x 5,00	21,85
5,00 x 12,00	63,00 x 6,30	23,23
3,00 x 14,00	69,00 x 3,90	26,70
4,00 x 14,00	70,00 x 5,60	24,33
5,00 x 14,00	69,00 x 6,30	31,63
4,00 x 16,00	71,00 x 5,00	34,03
4,00 x 18,00	77,00 x 5,00	37,50
5,00 x 18,00	78,00 x 6,90	33,63
6,00 x 18,00	77,00 x 8,00	44,74
5,00 x 20,00	80,00 x 6,30	63,54
6,30 x 20,00	83,00 x 8,60	49,06
6,00 x 25,00	100,00 x 8,00	113,06
6,30 x 25,00	100,00 x 8,00	113,06
8,00 x 25,00	100,00 x 26,00	108,36
10,00 x 31,50	125,00 x 30,00	214,71

BROCAS PARA FAZER O PONTO

Ref. BC75
Ref. BI75
Ref. BC76

HSSCo 5%

TiAIN

DIN 1412A

D₂

TOL h6

Utilizadas para a centralização previa dos furos feitos com a broca. Prepara o furo da broca. Aumenta a velocidade de ataque ao perfurar.

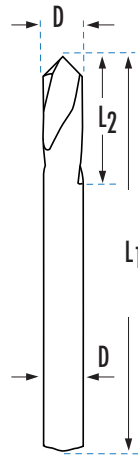

BC75 BI75 BC76 BH75

D mm	L1 x L2 mm	90°	90°	120°	142°
		€	€	€	€
2,0	49 x 8	19,11		19,11	
3,0	50 x 10	22,10	68,14	22,10	27,90
4,0	52 x 12	22,10	72,70	22,10	27,90
5,0	60 x 15	24,93	77,24	24,93	31,46
6,0	66 x 20	24,93	81,77	24,93	31,46
8,0	79 x 25	28,15	90,86	28,15	35,53
10,0	89 x 25	28,15	102,22	28,15	35,53
12,0	102 x 30	38,83	113,58	38,83	49,01
16,0	115 x 35	53,41		53,41	67,41
20,0	131 x 40	105,10		105,10	132,65

BROCA PARA FAZER O PONTO COM DUPLA PONTA

Ref. DP75

HSSCo 5%

TiAIN

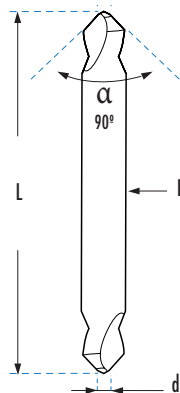
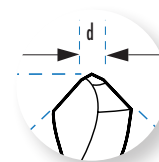

D x d mm	L mm	90°
		€
3,0 x 0,5	40	27,58
4,0 x 1,0	45	27,70
6,0 x 2,0	55	31,42
8,0 x 2,5	65	36,28
10,0 x 3,0	75	38,93
12,0 x 3,5	85	48,03
16,0 x 4,0	90	73,98
20,0 x 5,0	100	121,36



BROCAS PARA FAZER O PONTO

Utilizadas para a centralização previa dos furos feitos com a broca. Prepara o furo da broca. Aumenta a velocidade de ataque ao perfurar.

DIN
1412A

D2

TOL
h6
BROCA FAZER PONTO METAL DURO

 Ref. BC92
 Ref. BC93

MD
DIN
1412A
TOL
h6
DIN
6535HB

D mm	L1 x L2 mm	BC92		BC93	
		90° €	120° €	90° €	120° €
1,0	26 x 6	29,29			
1,5	32 x 9	29,73			
2,0	38 x 12	30,03			
3,0	45 x 12	30,46	31,33		
4,0	50 x 15	30,77	31,65		
5,0	50 x 18	36,66	37,70		
6,0	50 x 13	47,54	48,90		
8,0	60 x 23	66,93	68,83		
10,0	70 x 24	94,88	97,59		
12,0	70 x 24	122,50	126,00		
14,0	70 x 27	184,48	189,75		
16,0	75 x 29	225,44	219,00		
18,0	100 x 33	335,96	345,55		
20,0	100 x 35	397,83	388,31		

BROCA FAZER PONTO MULTITAREFA

Ref. BN75

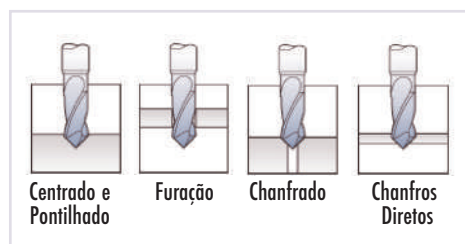
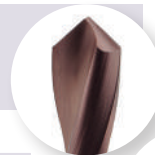
HSSCo
5%
120
Kg/mm²

	D mm	L1 x L2 mm	T* mm	BN75	
				90° €	
BN750300	3,0	50 x 6	0,3	32,64	
BN750400	4,0	52 x 8	0,4	35,39	
BN750500	5,0	60 x 10	0,5	38,43	
BN750600	6,0	66 x 12	0,6	41,19	
BN750800	8,0	79 x 14	0,8	49,72	
BN751000	10,0	89 x 16	1,0	59,48	
BN751200	12,0	102 x 18	1,2	77,79	
BN751400	14,0	115 x 21	1,4	109,81	
BN751600	16,0	115 x 24	1,6	122,01	



T*: espessura do núcleo

BROCAS PARA FAZER O PONTO SÉRIE LONGA

Ref. BL75

HSSCo
5%
TiAIN
90°

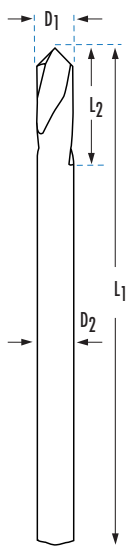

D1 mm	L1 x L2 mm	BL75	
		€	
3,0	80 x 10	45,43	
4,0	100 x 12	49,97	
5,0	120 x 15	54,52	
6,0	140 x 20	59,06	
8,0	140 x 25	65,87	
10,0	170 x 25	81,77	
12,0	170 x 30	99,95	
16,0	200 x 35	134,02	
20,0	200 x 40	170,36	

BROCAS PARA FAZER O PONTO COM CABO CÔNICO

Ref. BP11

HSSCo
5%
120
Kg/mm²
90°

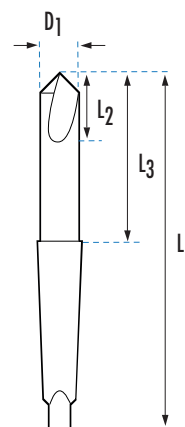
D1 mm	L1 mm	L2 mm	L3 mm	CM	BP11	
					€	
10,0	130	25	64	1	136,30	
12,0	130	30	64	1	147,65	
16,0	148	35	68	2	181,72	
20,0	148	40	68	2	227,16	
25,0	171	45	72	3	306,66	



BROCAS PARA PONTOS DE SOLDA

BROCA CURTA PARA MÁQUINAS PNEUMÁTICAS

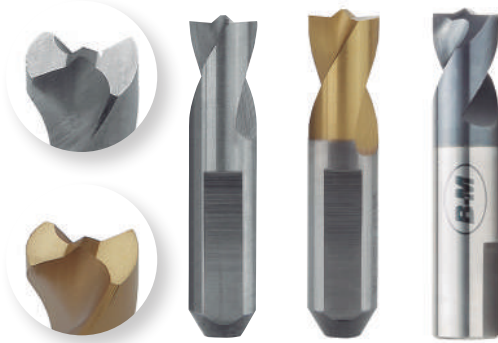

D1 mm	D2 mm	L1 x L2 mm	BC70	BC71	BC70MD*
			HSSCo 8%	HSSCo 8% TiN	MD TiAlN
			€	€	€
6,0	8,0	45 x 18	26,33	35,70	
6,5	6,5	40 x 18	27,45	40,88	66,97
8,0	8,0	38 x 18	21,58	35,70	
8,0	8,0	45 x 18	24,07	40,88	81,71
9,0	8,0	45 x 18	26,00	42,48	
10,0	8,0	45 x 18	28,49	48,19	

BROCA LONGA PARA MÁQUINAS ELETROPORTÁTEIS

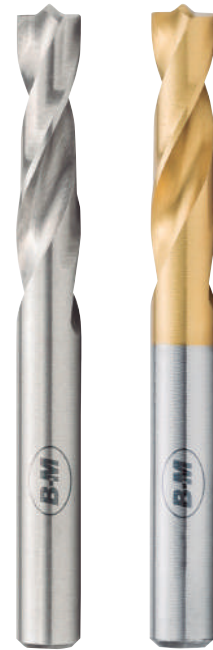

Ø mm	L1 x L2 mm	BC60	BC69
		HSSCo 5%	HSSCo 5% TiN
		€	€
6,0	66 x 26	13,02	22,84
7,0	74 x 34	18,67	29,73
8,0	79 x 36	17,26	32,21
10,0	89 x 44	21,31	34,02

* BROCA ESPECIAL BC70MD METAL DURO + TiAlN

- Broca especial para soldas ao boro.
- Usar com berbequim elétrico, não pneumático.
- 1200 RPM.
- Esforços de impulso altos.
- Sempre com "CUT-MAGIC".

CONJUNTO CORTADOR: ADAPTADOR, FRESA E PUNÇÃO



EBC70-1
24,80 €

FRESA CORTADORA: DE 9,5 mm



EBC70-2
17,93 €

PUNÇÃO GUIA



EBC70-3
1,09 €



EBC70

Composição:
1 Conjunto Cortador Ref. EBC70-1.
5 Fresas de 9,5 mm Ref. EBC70-2.
2 punções guia Ref. EBC70-3.
1 Broca Ref. BC60 Ø 8 mm.

112,46 €

BROCA LIMA-RASPA

PARA FURAR E CONTORNEAR EM MADEIRA, CHAPA METÁLICA E PLÁSTICO



* Broca especial para fabricantes de carroçarias.

Ø mm	L1 x L2 mm	BC80	BC81
		HSS	TiN
		€	€
6,0	90 x 60	18,16	28,51
8,0	90 x 60	23,36	36,49

BROCA-FRESA DE METAL DURO

Ref. BC91

MD

Utilizadas para furar, fresar e chanfrar.

50
HRC

Ti

INC

Ni

INOX

PVC

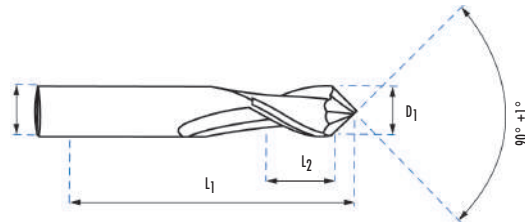
D2
TOL h6D1
TOL h9

BC91			
D1 mm	D2 mm	L1 x L2 mm	€
3,0	3,0	50 x 6	61,94
4,0	4,0	50 x 8	70,42
5,0	5,0	50 x 10	80,48
6,0	6,0	60 x 12	87,14
8,0	8,0	70 x 16	121,03
10,0	10,0	70 x 18	168,35
12,0	12,0	70 x 20	168,35
14,0	14,0	88 x 30	200,83
16,0	16,0	80 x 26	240,47
20,0	20,0	100 x 32	424,83

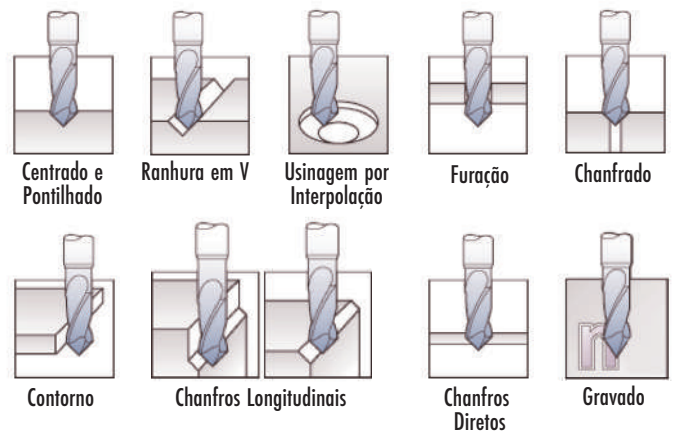

FLUOBROCAS PARA ROSCAGEM DE PAREDES FINAS

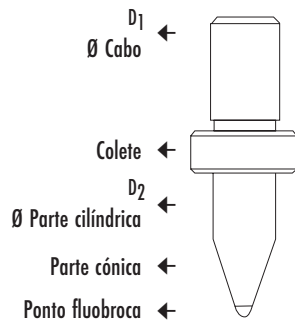
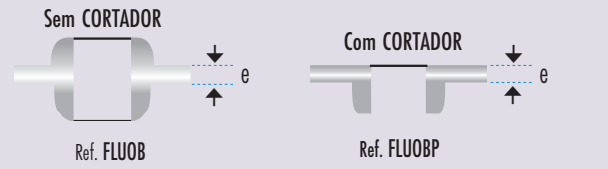

	e max. mm	D1 mm	D2 mm	R.P.M.	FLUOB		FLUOBP	
						€		€
M3x0,50	1,7	6	2,7	3000	FLUOBM03	138,52	FLUOBPM03	193,94
M4x0,70	1,7	6	3,7	2600	FLUOBM04	143,56	FLUOBPM04	200,99
M5x0,80	2,0	8	4,5	2500	FLUOBM05	149,94	FLUOBPM05	217,86
M6x1,00	2,0	8	5,3	2400	FLUOBM06	159,83	FLUOBPM06	232,19
M8x1,25	2,4	8	7,3	2200	FLUOBM08	197,18	FLUOBPM08	286,49
M10x1,50	2,6	10	9,2	2000	FLUOBM10	223,46	FLUOBPM10	324,67
M12x1,75	3,0	12	10,9	1800	FLUOBM12	239,60	FLUOBPM12	329,23
M16x2,00	3,4	16	14,8	1200	FLUOBM16	330,48	FLUOBPM16	422,10
M20x2,50	3,8	18	18,7	800	FLUOBM20	466,49	FLUOBPM20	595,04

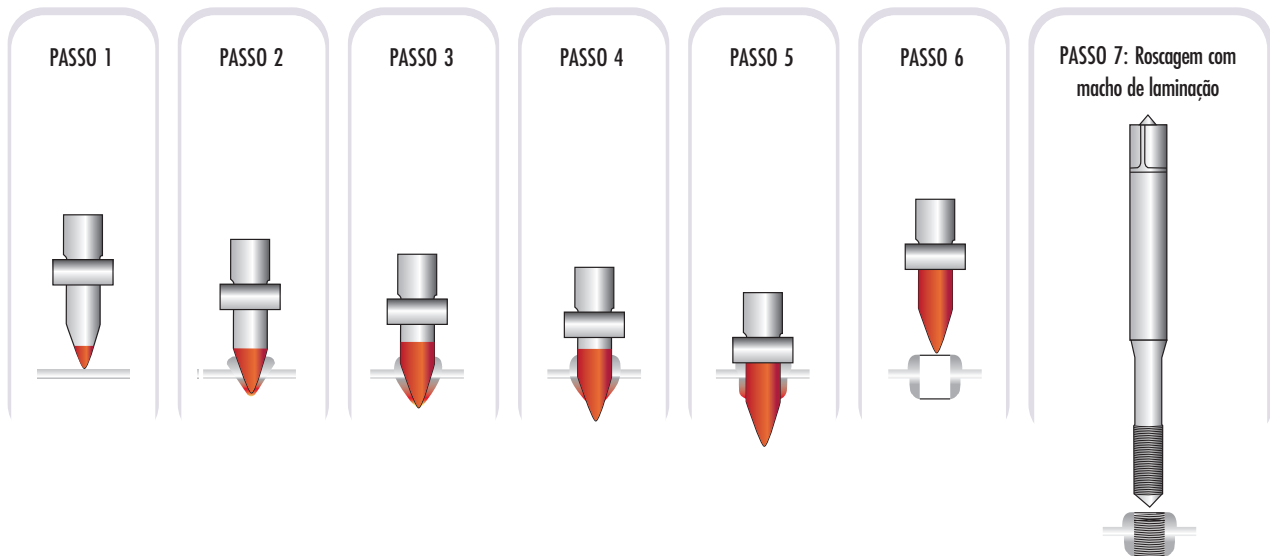

CUT MAGIC PASTY (250ml.e 750ml.)

			PASTY
		UNIDADE POR EMBALAGEM	€
ACPU00250	0,250 l.	1 Lata	28,92
ACPU00750	0,750 l.	1 Lata	43,76



Ref. ACPU00250

Ref. ACPU00750

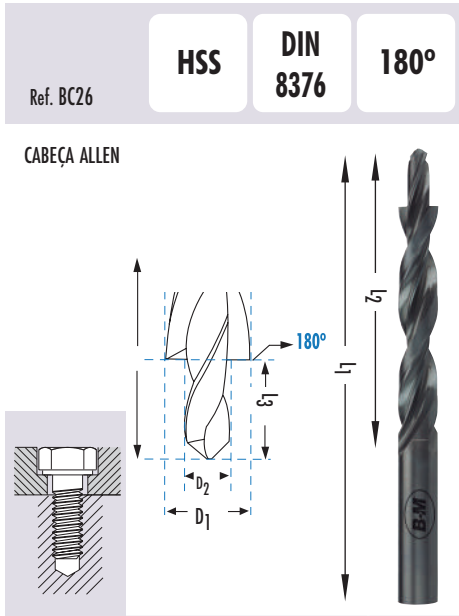
BROCAS BIDIAMETRAIS HSS
CABO CILÍNDRICO E CABO CÓNICO

BC26

	D2 mm	D1 mm	L1 x L2 mm	L3 mm	€
M3	3,4	6	93 x 57	9	61,86
M4	4,5	8	117 x 75	11	64,88
M5	5,5	10	133 x 87	13	77,11
M6	6,6	11	142 x 94	15	87,13
M8	9,0	15	169 x 114	19	107,05
M10	11,0	18	191 x 130	23	212,73



BC24

	D2 mm	D1 mm	L1 x L2 mm	L3 mm	€
M3	3,2	6,0	93 x 57	9	72,17
M4	4,3	8,0	117 x 75	11	75,69
M5	5,3	10,0	133 x 87	13	89,96
M6	6,4	11,5	142 x 94	15	102,77
M8	8,4	15,0	169 x 114	19	140,56
M10	10,5	19,0	198 x 135	23	217,04

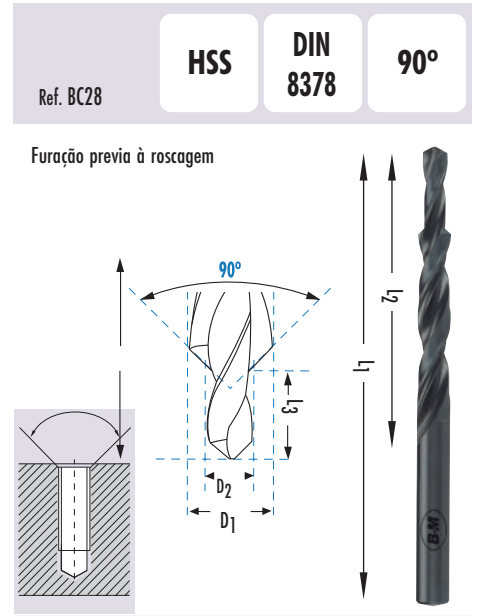

BC28

	D2 mm	D1 mm	L1 x L2 mm	L3 mm	€
M3	2,5	3,4	70 x 39	8,8	55,49
M4	3,3	4,5	80 x 47	11,8	59,70
M5	4,2	5,5	93 x 57	13,6	64,30
M6	5,0	6,6	101 x 63	16,5	73,17
M8	6,8	9,0	125 x 81	21,0	87,19
M10	8,5	11,0	142 x 94	25,5	101,70
M12	10,2	13,5	160 x 108	30,0	126,62

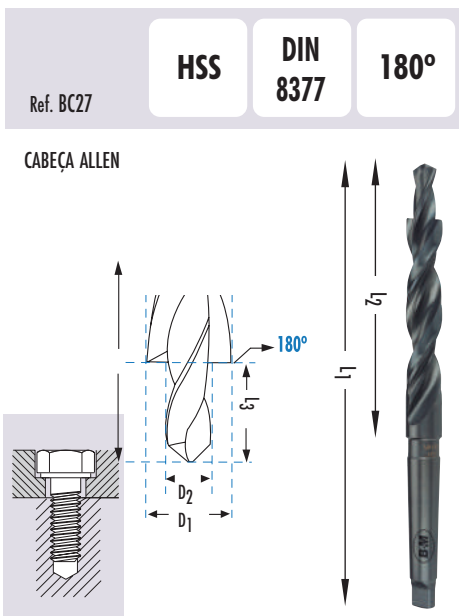

BC27

	D2 mm	D1 mm	L1 x L2 mm	L3 mm	CM	€
M6	6,6	11	175 x 94	15	1	155,02
M8	9,0	15	212 x 114	19	2	160,08
M10	11,0	18	228 x 130	23	2	180,49
M12	13,5	20	238 x 140	27	2	201,89
M14	15,5	24	281 x 160	31	3	286,29
M16	17,5	26	286 x 165	35	3	408,22
M18	20,0	30	296 x 175	39	3	456,48
M20	22,0	33	334 x 185	43	4	516,15

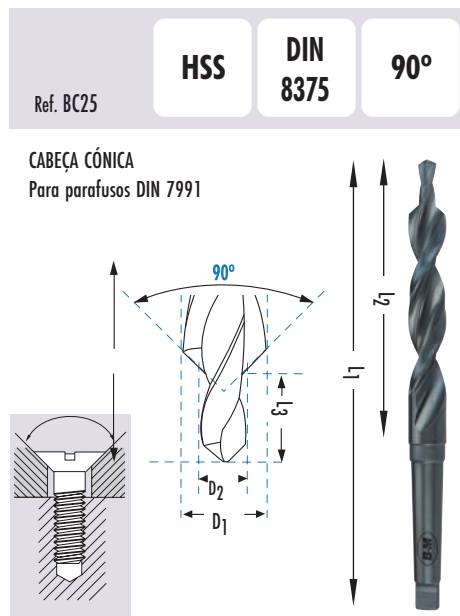

BC25

	D2 mm	D1 mm	L1 x L2 mm	L3 mm	CM	€
M5	5,5	11,0	175 x 94	13	1	154,86
M6	6,6	13,0	182 x 101	15	1	157,97
M8	9,0	17,2	228 x 130	19	2	188,27
M10	11,0	21,5	248 x 150	23	2	222,90

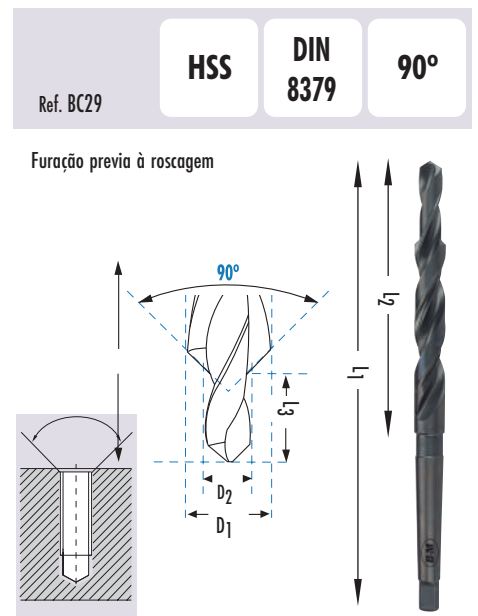

BC29

	D2 mm	D1 mm	L1 x L2 mm	L3 mm	CM	€
M8	6,8	9,0	162 x 81	21,0	1	142,03
M10	8,5	11,0	175 x 94	25,5	1	154,76
M12	10,2	13,5	189 x 108	30,0	1	182,79
M14	12,0	15,5	218 x 120	34,5	2	195,06
M16	14,0	17,5	228 x 130	38,5	2	210,51
M18	15,5	20,0	238 x 140	43,5	2	235,45
M20	17,5	22,0	248 x 150	47,5	2	284,69

BROCAS EXTRA-CURTAS ESCALONADAS

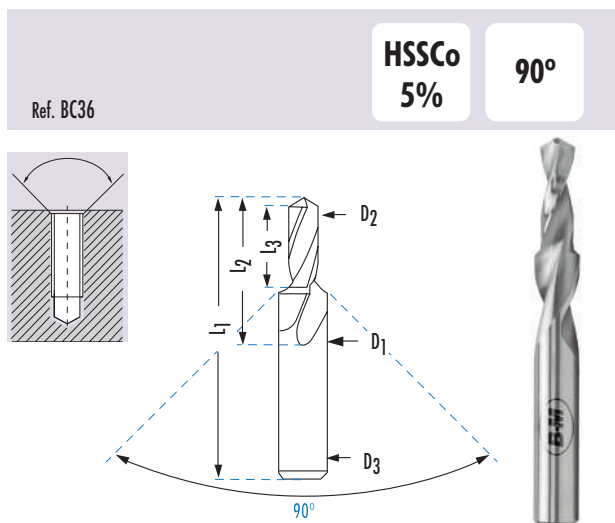

BC36

	D1 mm	D2 mm	D3 mm	L1 x L2 mm	L3 mm	€
M3	3,4	2,5	3,4	52 x 20	8	30,05
M4	4,5	3,3	4,5	58 x 24	11	31,47
M5	5,5	4,2	5,5	66 x 28	13	32,90
M6	6,6	5,0	6,6	70 x 31	16	35,75
M8	9,0	6,8	9,0	84 x 40	20	42,91
M10	11,0	8,5	11,0	95 x 47	24	56,50
M12	14,0	10,2	14,0	107 x 54	29	75,80
M14	16,0	12,0	16,0	115 x 56	32	193,08
M16	18,0	14,0	18,0	135 x 60	34	243,14

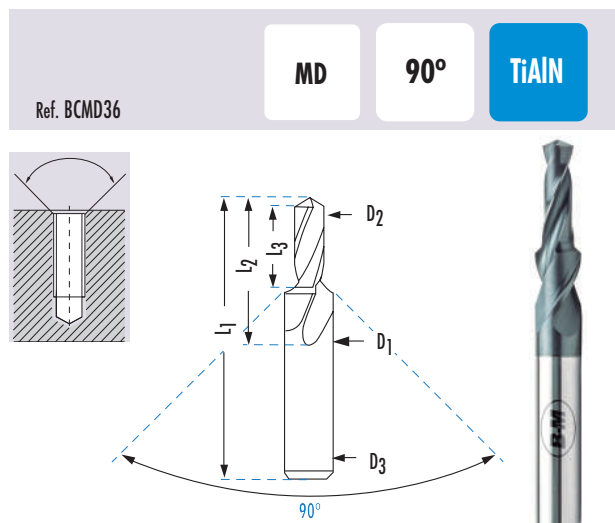

BCMD36

	D1 mm	D2 mm	D3 mm	L1 x L2 mm	L3 mm	€
M3	6,0	2,5	6,0	66 x 20	8,8	57,21
M4	6,0	3,3	6,0	66 x 24	11,4	66,74
M5	6,0	4,2	6,0	66 x 28	13,6	71,51
M6	8,0	5,0	8,0	79 x 31	16,5	83,44
M8	10,0	6,8	10,0	89 x 40	21,0	114,42
M10	12,0	8,5	12,0	102 x 47	25,5	154,94
M12	14,0	10,2	14,0	107 x 54	30,0	214,54

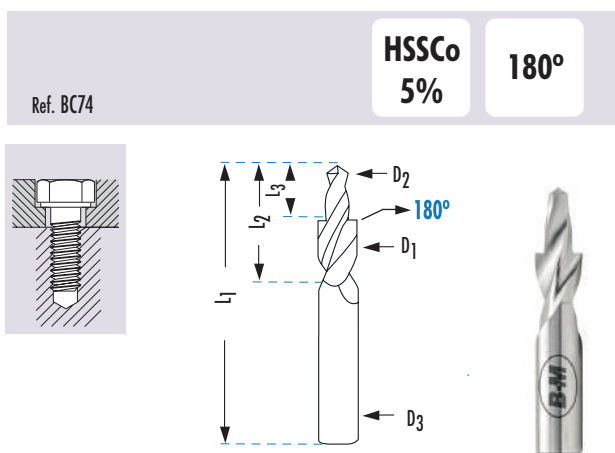

BC74

	D1 mm	D2 mm	D3 mm	L1 x L2 mm	L3 mm	€
M2	4,3	2,4	4,3	45 x 12	6	20,74
M3	6,0	3,4	6,0	45 x 18	9	21,09
M4	8,0	4,5	8,0	50 x 22	11	25,04
M5	10,0	5,5	10,0	55 x 26	13	27,89
M6	11,0	6,6	11,0	63 x 30	15	35,05
M8	15,0	9,0	12,5	100 x 34	19	65,80
M10	18,0	11,0	12,5	110 x 42	23	95,83
M12	20,0	14,0	12,5	110 x 34	28	125,86
M14	24,0	16,0	12,5	120 x 42	34	254,59

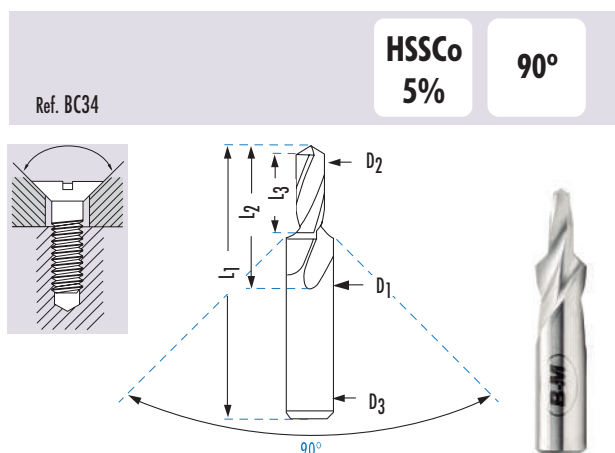

BC34

	D1 mm	D2 mm	D3 mm	L1 x L2 mm	L3 mm	€
M2	4,6	2,2	4,6	45 x 12	6	20,74
M3	6,5	3,2	6,5	45 x 18	9	21,09
M4	8,6	4,3	8,6	50 x 26	11	25,04
M5	10,4	5,3	10,4	55 x 30	13	27,89
M6	12,4	6,4	12,4	63 x 34	15	35,05
M8	16,4	8,4	12,5	100 x 42	19	65,80
M10	20,4	10,5	12,5	110 x 34	23	95,83
M12	25,0	13,0	12,5	120 x 42	28	254,59

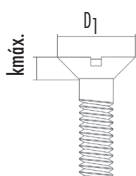

DIN 7991

	M2	M2.5	M3	M4	M5	M6	M8	M10	M12	M14	M16	M18	M20
Kmáx. D1	1,2	1,5	1,7	2,3	2,8	3,3	4,4	5,5	6,5	7	7,5	8	8,5
	4	5	6	8	10	12	16	20	24	27	30	33	36

BROCAS HELICOIDAIS COM CABO CÔNICO DIN 345
**DIN
345**

Para fazer furos maiores que Ø25 mm, é recomendável fazer um orifício anterior igual a um terço do diâmetro final a ser perfurado.
Exemplo; se você for usar uma broca de Ø30mm, faça um pré-furo de Ø10mm

			BC11	BC22	BC32	BC21	BC13
Ø mm	L1 x L2 mm	CM	€	€	€	€	€
10,75	175 x 94	1	40,87				
11,00	175 x 94	1	35,31	103,90		50,50	94,31
11,25	175 x 94	1	42,67				
11,50	175 x 94	1	37,12	108,19		51,82	94,31
11,75	175 x 94	1	42,68				
12,00	182 x 101	1	37,31	111,59		38,32	98,46
12,25	182 x 101	1	47,52				
12,50	182 x 101	1	39,93	116,81		53,46	98,66
12,75	182 x 101	1	47,53				
13,00	182 x 101	1	41,64	114,31	86,71	54,59	112,30
13,25	189 x 101	1	52,61				
13,50	189 x 101	1	43,94	149,73	104,78	56,33	111,99
13,75	189 x 101	1	52,61				
14,00	189 x 108	1	43,97	146,98	99,61	45,24	122,02
14,25	212 x 114	2	56,98				
14,50	212 x 114	2	49,49	162,65	122,24	75,56	122,00
14,75	212 x 114	2	56,96				
15,00	212 x 114	2	49,49	149,91	116,19	75,56	138,06
15,25	218 x 120	2	58,60				
15,50	218 x 120	2	50,94	165,75	119,92	77,78	147,02
15,75	218 x 120	2	58,60	204,42	149,89		
16,00	218 x 120	2	51,23	157,72	119,92	51,30	146,95
16,25	223 x 125	2	66,25				
16,50	223 x 125	2	57,90	167,47	127,27	79,35	147,41
16,75	223 x 125	2	66,25				
17,00	223 x 125	2	57,89	164,95	127,27	78,94	156,17
17,25	228 x 130	2	73,36				
17,50	228 x 130	2	64,02	174,90	134,63	85,05	155,97
17,75	228 x 130	2	73,36	238,52	179,86		
18,00	228 x 130	2	61,48	171,58	143,89	58,56	168,81
18,25	233 x 135	2	80,66				
18,50	233 x 135	2	70,47	188,28	149,43	87,13	197,30
18,75	233 x 135	2	81,19				
19,00	233 x 135	2	70,70	184,15	149,43	73,34	197,01
19,25	238 x 140	2	87,82				
19,50	238 x 140	2	76,46	212,80	156,79	93,36	221,25
19,75	238 x 140	2	88,43				
20,00	238 x 140	2	76,49	205,69	156,79	77,13	221,79
20,25	243 x 145	2	91,48				
20,50	243 x 145	2	79,28	236,91	182,62	94,77	225,36
20,75	243 x 145	2	91,48				
21,00	243 x 145	2	79,28	239,58	182,62	94,34	225,36
21,25	248 x 150	2	100,94				
21,50	248 x 150	2	87,43	269,90	199,22	99,81	245,73
21,75	248 x 150	2	100,94	349,01	249,03		
22,00	248 x 150	2	87,60	243,41	199,22	89,83	245,73
22,00*	265 x 150	3	119,07				
22,25	248 x 150	2	110,48				
22,50	253 x 155	2	95,86	301,87	210,28	108,68	246,11
22,75	253 x 155	2	110,48				
23,00	253 x 155	2	95,63	283,57	228,72	107,89	266,92
23,25	276 x 155	3	121,85				
23,50	276 x 155	3	106,13	301,28	275,75	130,01	266,75
23,75	281 x 160	3	122,00				
24,00	281 x 160	3	105,90	305,16	254,57	111,30	293,42

	BC11	BC22	BC32	BC21	BC13
MATERIAL	HSS	HSSCo 5%	HSSCo 5%	HSS	PMD
AFIAÇÃO					
ÂNGULO PONTA	118°	135°	135°	118°	118°
HÉLICE	30° "N"	30° "N"	38° "N"	30° "N"	30° "N"
ACABAMENTO	OX	OX	OX	TiN	BRILHANTE
APLICAÇÃO	70 Kg/mm²	120 Kg/mm²	INOX	PRODUÇÃO	FUNDAÇÃO

Cone reforçado, DIN 346, sob demanda.

BROCAS HELICOIDAIS COM CABO CÔNICO DIN 345

DIN 345



Para fazer furos maiores que Ø25 mm, é recomendável fazer um orifício anterior igual a um terço do diâmetro final a ser perfurado.
Exemplo: se você for usar uma broca de Ø30mm, faça um pré-furo de Ø10mm

			BC11	BC22	BC32	BC21	BC13							
Ø mm	L1 x L2 mm	CM	€	€	€	€	€	Ø mm	L1 x L2 mm	CM	€	€	€	€
31,00	301x180	3	191,53	449,13		207,93		31,00	301x180	3	191,53	449,13	207,93	
31,25	301x180	3	233,06					31,25	301x180	3	233,06			
31,50	301x180	3	201,41	689,91				31,50	301x180	3	201,41	689,91		
31,75	306x185	3	233,06		604,12			31,75	306x185	3	233,06		604,12	
32,00	334x185	4	201,75	519,57	483,28	217,56	559,55*	32,00	334x185	4	201,75	519,57	483,28	217,56
32,00	334x185	3	375,70					32,00	334x185	3	375,70			
32,25	334x185	4	272,02					32,25	334x185	4	272,02			
32,50	334x185	4	231,75					32,50	334x185	4	231,75			
32,75	334x185	4	272,02					32,75	334x185	4	272,02			
33,00	334x185	4	230,37	594,01		236,79	689,59*	33,00	334x185	4	230,37	594,01	236,79	689,59*
33,25	334x185	4	284,14					33,25	334x185	4	284,14			
33,50	334x185	4	251,32					33,50	334x185	4	251,32			
33,75	339x190	4	285,69					33,75	339x190	4	285,69			
34,00	339x190	4	250,55	669,29		336,48	690,75*	34,00	339x190	4	250,55	669,29	336,48	690,75*
34,25	339x190	4	312,21					34,25	339x190	4	312,21			
34,50	339x190	4	273,66					34,50	339x190	4	273,66			
34,75	339x190	4	312,21	727,66				34,75	339x190	4	312,21	727,66		
35,00	339x190	4	275,02	703,28	662,16	371,01		35,00	339x190	4	275,02	703,28	662,16	371,01
35,25	339x190	4	334,61					35,25	339x190	4	334,61			
35,50	339x190	4	293,58					35,50	339x190	4	293,58			
35,75	344x195	4	343,59					35,75	344x195	4	343,59			
36,00	344x195	4	294,30	755,59		385,08	1.109,34*	36,00	344x195	4	294,30	755,59	385,08	1.109,34*
36,25	344x195	4	361,12					36,25	344x195	4	361,12			
36,50	344x195	4	311,26					36,50	344x195	4	311,26			
36,75	344x195	4	361,07					36,75	344x195	4	361,07			
37,00	344x195	4	310,85	706,22		396,30	1.198,18*	37,00	344x195	4	310,85	706,22	396,30	1.198,18*
37,25	344x195	4	384,85					37,25	344x195	4	384,85			
37,50	344x195	4	387,17					37,50	344x195	4	387,17			
37,75	344x195	4	417,53					37,75	344x195	4	417,53			
38,00	349x200	4	326,47	815,02		407,63		38,00	349x200	4	326,47	815,02	407,63	
38,25	349x200	4	406,71					38,25	349x200	4	406,71			
38,50	349x200	4	347,40					38,50	349x200	4	347,40			
38,75	349x200	4	406,71					38,75	349x200	4	406,71			
39,00	349x200	4	347,69	833,98		422,89	1.324,94*	39,00	349x200	4	347,69	833,98	422,89	1.324,94*
39,25	349x200	4	409,09					39,25	349x200	4	409,09			
39,50	349x200	4	368,23					39,50	349x200	4	368,23			
39,75	349x200	4	409,09					39,75	349x200	4	409,09			
40,00	349x200	4	367,75	873,94		436,63	1.366,77*	40,00	349x200	4	367,75	873,94	436,63	1.366,77*
40,50	354x205	4	385,50					40,50	354x205	4	385,50			
41,00	354x205	4	385,98	918,69				41,00	354x205	4	385,98	918,69		
41,50	354x205	4	410,27					41,50	354x205	4	410,27			
42,00	354x205	4	409,43	961,94				42,00	354x205	4	409,43	961,94		
42,50	354x205	4	430,29					42,50	354x205	4	430,29			
43,00	359x210	4	430,30	1.008,64				43,00	359x210	4	430,30	1.008,64		
43,50	359x210	4	450,51					43,50	359x210	4	450,51			
44,00	359x210	4	450,79	1.047,33				44,00	359x210	4	450,79	1.047,33		
44,50	359x210	4	471,46					44,50	359x210	4	471,46			
45,00	359x210	4	471,82	1.095,28				45,00	359x210	4	471,82	1.095,28		
45,50	364x215	4	490,24					45,50	364x215	4	490,24			
46,00	364x215	4	488,18					46,00	364x215	4	488,18			
46,50	364x215	4	510,25					46,50	364x215	4	510,25			
47,00	364x215	4	510,01	1.183,45				47,00	364x215	4	510,01	1.183,45		
47,50	364x215	4	527,38					47,50	364x215	4	527,38			
48,00	369x220	4	527,01	1.233,05				48,00	369x220	4	527,01	1.233,05		
48,50	369x220	4	548,31					48,50	369x220	4	548,31			

Cone reforçado, DIN 346, sob demanda.

*Até o fim das existências.

Brocas Metal

Rosa Cinza

BROCA HELICOIDAL COM CABO CÓNICO DIN 345

Ref. BC11

**DIN
345**
HSS

OX

Brocas Metal

Cinza



BC11			
Ø mm	L1 x L2 mm	CM	€
49,00	369x220	4	546,01
49,50	369x220	4	563,18
50,00	369x220	4	569,22
50,50	369x220	4	815,08
51,00	412x225	5	667,49
51,50	412x225	5	894,63
52,00	412x225	5	713,37
52,50	412x225	5	916,41
53,00	412x225	5	764,01
53,50	412x225	5	958,63
54,00	417x230	5	840,75
54,50	417x230	5	949,03
55,00	417x230	5	832,30
56,00	417x230	5	936,50
57,00	422x235	5	994,89
58,00	422x235	5	1.003,40
59,00	422x235	5	1.033,53
60,00	422x235	5	978,36
61,00	427x240	5	1.147,56
62,00	427x240	5	1.195,22
63,00	427x240	5	1.264,00
64,00	432x245	5	1.333,61
65,00	432x245	5	1.276,93
66,00	432x245	5	1.439,68
67,00	432x245	5	1.486,10
68,00	437x250	5	1.524,65
69,00	437x250	5	1.572,05
70,00	437x250	5	1.419,57
71,00	437x250	5	1.638,94
72,00	442x255	5	1.672,89
73,00	442x255	5	1.716,68
74,00	442x255	5	1.766,91
75,00	442x255	5	1.664,38
76,00	447x260	5	1.959,80
77,00	514x260	6	2.103,11
78,00	514x260	6	2.144,21
79,00	514x260	6	2.187,42
80,00	514x260	6	2.753,24
81,00	519x265	6	3.032,29
82,00	519x265	6	3.108,06
83,00	519x265	6	3.167,67
84,00	519x265	6	3.234,92
85,00	519x265	6	3.314,83
86,00	524x270	6	3.387,20
87,00	524x270	6	3.459,14
88,00	524x270	6	3.548,03
89,00	524x270	6	3.616,71
90,00	524x270	6	3.720,22
91,00	529x275	6	3.923,75
92,00	529x275	6	3.946,37
93,00	529x275	6	4.087,10
94,00	529x275	6	4.170,16
95,00	529x275	6	4.255,85
96,00	534x280	6	4.396,03
97,00	534x280	6	4.432,91
98,00	534x280	6	4.531,80
99,00	534x280	6	4.613,75
100,00	534x280	6	4.701,77



Ref. EXPBC11MC

EXPOSITOR 15 BROCAS CABO CÓNICO

Cone Morse	14	15	16	17	18	DIN
nº 1	1	1	1	1	1	345
nº 2	19	20	21	22	23	
	1	1	1	1	1	
nº 3	24	25	26	28	30	
	1	1	1	1	1	

DIMENSÕES: Largo 280 x fundo 212/50 x altura 155 mm

1.337,18 €

SOBRETAXAS POR REBAIXAR CABOS CÓNICOS

nº 2-1

nº 2-0

nº 3-2

nº 3-1

nº 4-3

nº 4-2

€ LÍQUIDO

53,30

79,95

Cone reforçado, DIN 346, sob demanda.

BROCA CABO CÔNICO M42 (8%) COBALTO PARA FURAR MATERIAIS DUROS E RESISTENTES

Ref. BC73

HSSCo
8%



OX

HARDOX
450

BC73

	D1 mm	L1 mm	L2 mm	CM	€
BC731000	10,00	175	76	2	59,19
BC731020	10,20	175	76	2	59,19
BC731100	11,00	175	76	2	59,19
BC731200	12,00	179	81	2	64,83
BC731250	12,50	179	81	2	64,83
BC731300	13,00	179	81	2	64,83
BC731400	14,00	184	86	2	69,01
BC731450	14,50	187	89	2	69,92
BC731500	15,00	187	89	2	70,36
BC731550	15,50	187	89	2	79,93
BC731600	16,00	187	89	2	83,73
BC731650	16,50	190	92	2	87,59
BC731700	17,00	190	92	2	89,25
BC731800	18,00	190	92	2	90,59
BC731850	18,50	213	95	3	100,97
BC731900	19,00	213	95	3	102,94
BC732000	20,00	213	95	3	109,43
BC732100	21,00	219	102	3	119,18
BC732200	22,00	222	105	3	137,01
BC732400	24,00	222	105	3	147,61
BC732500	25,00	225	108	3	174,90
BC732600	26,00	270	124	4	207,25
BC732700	27,00	270	124	4	222,89
BC732800	28,00	270	124	4	231,43
BC733000	30,00	270	124	4	257,43
BC733200	32,00	280	133	4	299,61
BC733500	35,00	292	136	4	374,36
BC733600	36,00	292	146	4	393,74
BC734000	40,00	298	152	4	481,24
BC734500	45,00	298	152	4	654,48
BC735000	50,00	356	152	5	768,86
BC735500	55,00	360	156	5	913,46
BC736000	60,00	360	156	5	1.114,81

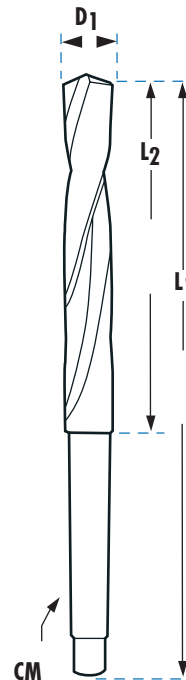

Broca especial para HARDOX 450



Para fazer furos maiores que Ø25 mm, é recomendável fazer um orifício anterior igual a um terço do diâmetro final a ser perfurado. Exemplo; se você for usar uma broca de Ø30mm, faça um pré-furo de Ø10mm

Ref. BC22...FT

DIN
345

HSSCo
5%

TiN



HARDOX
450

BC22...FT

	D1 mm	L1 mm	L2 mm	CM	€
BC221600FT	16,00	218	120	2	101,49
BC221800FT	18,00	228	130	2	110,40
BC222000FT	20,00	238	140	2	132,36
BC222200FT	22,00	248	150	2	156,63
BC222400FT	24,00	281	160	3	196,36
BC222500FT	25,00	281	160	3	205,71
BC222600FT	26,00	286	165	3	243,17
BC222800FT	28,00	291	170	3	299,00
BC223000FT	30,00	296	175	3	295,47
BC223200FT	32,00	334	185	4	334,33
BC223400FT	34,00	339	190	4	430,66
BC223600FT	36,00	344	195	4	486,19



- A melhor solução para fazer furos de grande diâmetro em materiais de alta dureza
- Afição especial para materiais muito duros, com corte corrigido e retocado do corte lateral da borda



Esta broca tem sido usada historicamente para a perfuração de trilhos ferroviários.

Broca especial para HARDOX 450

BROCAS HELICOIDAIS COM CABO CÓNICO SERIE LONGA
**DIN
341**

Ref. BC12



Ref. BC56



	BC12			BC56			BC12			BC56		
	Ø mm	L1 x L2	CM	Ø mm	L1 x L2	CM	Ø mm	L1 x L2	CM	Ø mm	L1 x L2	CM
MATERIAL	HSS			HSSCo 5%								
AFIAÇÃO												
ÂNGULO PONTA	118°			135°								
HÉLICE	30° "N"			38° "gr"								
ACABAMENTO	OX			OX								
APLICAÇÃO	70 Kg/mm ²			120 Kg/mm ²								
	Ø mm	L1 x L2	CM	€	€	€	€	€	€	€	€	€
5,00	155x74	1	25,67									
5,50	161x80	1	34,42									
6,00	161x80	1	27,30									
6,50	167x86	1	27,88									
7,00	174x93	1	29,60									
7,50	174x93	1	31,14									
8,00	181x100	1	31,67									
8,50	181x100	1	31,67									
9,00	188x107	1	34,94									
9,50	188x107	1	38,22									
10,00	197x116	1	39,36	82,60								
10,25	197x116	1	47,10									
10,50	197x116	1	40,94									
10,75	206x125	1	60,02									
11,00	206x125	1	39,36	90,43								
11,25	206x125	1	60,02									
11,50	206x125	1	39,36									
11,75	206x125	1	54,18									
12,00	215x134	1	42,09	101,71								
12,25	215x134	1	54,18									
12,50	215x134	1	43,18									
12,75	215x134	1	58,12									
13,00	215x134	1	43,18	106,39								
13,25	223x142	1	60,59									
13,50	223x142	1	47,06									
13,75	223x142	1	65,47									
14,00	223x142	1	48,65	122,32								
14,25	245x147	2	81,69									
14,50	245x147	2	61,21									
14,75	245x147	2	81,69									
15,00	245x147	2	61,21	142,04								
15,25	251x153	2	80,89									
15,50	251x153	2	60,07	147,82								
15,75	251x153	2	83,87									
16,00	251x153	2	62,29	147,82								
16,25	257x159	2	91,23									
16,50	257x159	2	67,72	156,54								
16,75	257x159	2	91,23									
17,00	257x159	2	67,72	156,54								
17,25	263x165	2	89,28									
17,50	263x165	2	71,97	165,21								
17,75	263x165	2	101,52									
18,00	263x165	2	75,37	176,82								
18,25	269x171	2	101,92									
18,50	269x171	2	81,80	184,04								
18,75	269x171	2	105,19									
19,00	269x171	2	79,53	184,04								
19,25	275x177	2	110,39									
19,50	275x177	2	89,39	191,88								
19,75	275x177	2	111,76									
20,00	275x177	2	85,27	191,88								
20,50	282x184	2	103,41	223,19								
21,00	282x184	2	97,83	223,19								
21,50	289x191	2	118,03	243,46								
22,00	289x191	2	111,36	243,46								
22,50	296x198	2	121,70	257,95								
23,00	296x198	2	111,43	278,26								
23,50	319x198	3	141,70	286,93								
24,00	327x206	3	143,03	313,04								
24,50	327x206	3	151,93	324,64								
25,00	327x206	3	143,01	304,35								
25,50	335x214	3	172,46									
26,00	335x214	3	150,77	359,42								
26,50	335x214	3	177,90									
27,00	343x222	3	162,75	394,18								
27,50	343x222	3	209,73									
28,00	343x222	3	185,76	405,77								
28,50	351x230	3	248,91									
29,00	351x230	3	203,41	440,58								
29,50	351x230	3	249,13									
30,00	351x230	3	208,62	463,76								
30,50	360x239	3	284,86									
31,00	360x239	3	263,46	521,73								
31,50	360x239	3	305,57									
32,00	397x248	4	264,51	579,70								
32,50	397x248	4	334,86									
33,00	397x248	4	281,86									
33,50	397x248	4	330,62									
34,00	406x257	4	343,08									
34,50	406x257	4	363,27									
35,00	406x257	4	345,15									
35,50	406x257	4	363,27									
36,00	416x267	4	397,14									
36,50	416x267	4	502,59									
37,00	416x267	4	427,76									
37,50	416x267	4	498,05									
38,00	426x277	4	447,82									
38,50	426x277	4	567,71									
39,00	426x277	4	465,27									
39,50	426x277	4	567,71									
40,00	426x277	4	503,21									
41,00	436x287	4	643,43									
42,00	436x287	4	671,13									
43,00	447x298	4	714,25									
44,00	447x298	4	725,13									
45,00	447x298	4	764,25									
46,00	459x310	4	804,15									
47,00	459x310	4	846,34									
48,00	470x321	4	884,65									
49,00	470x321	4	913,55									
50,00	470x321	4	945,82									
55,00	505x310	5	1.236,74									

BROCAS HELICOIDAIS COM CABO CÔNICO SERIE EXTRA-LONGA

DIN
1870
I/II

Ref. BC14



Ref. BC41



MATERIAL	BC14		BC41		BC14			BC41				
	HSS	HSSCo 5%	Ø mm	L1 x L2	CM	€	€	Ø mm	L1 x L2	CM	€	€
AFIAÇÃO			17,00	355x230	2	210,35	369,95	29,00	460x305	3	491,37	1.148,82
ÂNGULO PONTA			17,00	445x295	2	252,91	517,10	29,00	580x385	3	704,53	1.559,41
HÉLICE			17,50	370x245	2	231,46	416,08	29,50	460x305	3	508,74	1.315,21
ACABAMENTO			17,50	465x310	2	278,49	562,69	29,50	580x385	3	710,35	1.814,93
APLICAÇÃO			18,00	370x245	2	231,46	404,91	30,00	460x305	3	508,74	1.201,90
			18,00	465x310	2	278,49	533,62	30,00	580x385	3	710,35	1.621,10
			18,50	370x245	2	251,10	467,89	31,00	480x320	4	570,25	1.521,12
			18,50	465x310	2	300,99	638,46	31,00	610x410	4	757,32	
			19,00	370x245	2	250,97	466,79	32,00	505x320	4	596,25	
			19,00	465x310	2	300,99	595,98	32,00	635x410	4	794,62	
			19,50	385x260	2	268,04	522,03	33,00	505x320	4	649,71	
			19,50	490x325	2	325,73	668,48	33,00	635x410	4	879,68	
			20,00	385x260	2	267,99	512,89	34,00	530x340	4	704,50	
			20,00	490x325	2	325,73	668,13	34,00	665x430	4	912,81	
			20,50	385x260	2	303,49	682,64	35,00	530x340	4	725,62	
			20,50	490x325	2	364,44	786,02	35,00	665x430	4	991,93	
			21,00	385x260	2	303,49	626,95	36,00	530x340	4	782,83	
			21,00	490x325	2	364,44	778,87	36,00	665x430	4	1.041,59	
			21,50	405x270	2	323,66	738,43	37,00	530x340	4	802,63	
			21,50	515x345	2	391,11	922,37	37,00	665x430	4	1.157,31	
			22,00	405x270	2	323,66	669,58	38,00	555x360	4	875,53	
			22,00	515x345	2	391,11	899,15	38,00	695x460	4	1.225,52	
			22,50	405x270	2	368,82	786,02	39,00	555x360	4	912,49	
			22,50	515x345	2	441,52	976,21	39,00	695x460	4	1.283,99	
			23,00	405x270	2	368,82	766,59	40,00	555x360	4	961,93	
			23,00	515x345	2	441,52	922,37	40,00	695x460	4	1.224,74	
			23,50	425x270	3	405,24	960,65	41,00	555x360	4	1.082,33	
			23,50	535x345	3	491,37	1.171,69	41,00	695x460	4	1.392,06	
			24,00	440x290	3	405,24	877,18	42,00	555x360	4	1.117,99	
			24,00	555x365	3	491,37	1.073,38	42,00	695x460	4	1.486,30	
			24,50	440x290	3	419,96	1.036,44	43,00	585x385	4	1.165,88	
			24,50	555x365	3	517,86	1.231,92	43,00	735x490	4	1.516,55	
			25,00	440x290	3	419,96	924,40	44,00	585x385	4	1.220,93	
			25,00	555x365	3	517,86	1.101,78	44,00	735x490	4	1.569,85	
			25,50	440x290	3	434,07	1.102,86	45,00	585x385	4	1.257,63	
			25,50	555x365	3	572,06	1.436,19	45,00	735x490	4	1.642,97	
			26,00	440x290	3	434,07	999,46	46,00	585x385	4	1.296,07	
			26,00	555x365	3	572,06	1.292,33	46,00	735x490	4	1.716,42	
			26,50	440x290	3	444,51	1.119,90	47,00	585x385	4	1.404,05	
			26,50	555x365	3	590,23	1.541,97	47,00	735x490	4	1.800,68	
			27,00	460x305	3	444,51	1.038,81	48,00	605x405	4	1.404,66	
			27,00	580x385	3	590,23	1.367,92	48,00	765x510	4	1.905,42	
			27,50	460x305	3	474,18	1.218,40	49,00	605x405	4	1.447,43	
			27,50	580x385	3	638,52	1.632,81	49,00	765x510	4	1.977,95	
			28,00	460x305	3	474,18	1.100,50	50,00	605x405	4	1.490,03	
			28,00	580x385	3	638,52	1.486,55	50,00	765x510	4	2.029,66	
			28,50	460x305	3	491,37	1.292,69					
			28,50	580x385	3	704,53	1.700,52					

BROCA CABO CÔNICO HSS COM REFRIGERAÇÃO INTERIOR

Ref. BC87

 $\leq 10xD$
**DIN
341**
HSS

OX

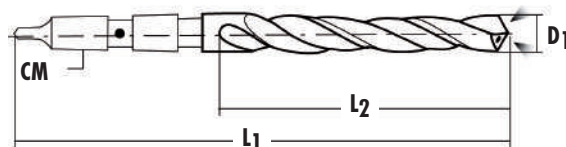
**AFIAÇÃO ESPECIAL 170°
COM PONTA GUIA
CENTRAGEM PRECISA**

BC87					
	D1 mm	L1 mm	L2 mm	CM	€
BC871000	10,0	268	116	3	507,50
BC871050	10,5	268	116	3	514,49
BC871100	11,0	278	125	3	514,49
BC871200	12,0	287	134	3	525,73
BC871300	13,0	287	134	3	525,73
BC871350	13,5	285	142	3	525,73
BC871400	14,0	285	142	3	525,73
BC871450	14,5	245	147	2	543,65*
BC871500	15,0	300	147	3	543,65
BC871550	15,5	251	153	2	561,92*
BC871600	16,0	306	153	3	561,92
BC871650	16,5	257	159	2	561,92*
BC871700	17,0	311	159	3	561,92
BC871750	17,5	318	165	3	597,72
BC871800	18,0	318	165	3	597,72
BC871900	19,0	324	171	3	616,10
BC872000	20,0	330	177	3	652,26
BC872100	21,0	343	184	3	688,74
BC872200	22,0	350	191	3	731,86

BC87					
	D1 mm	L1 mm	L2 mm	CM	€
BC872300	23,0	357	198	3	724,86
BC872400	24,0	365	206	3	724,86
BC872500	25,0	365	206	3	739,86
BC872600	26,0	373	214	3	815,73
BC872700	27,0	375	222	4	851,88
BC872800	28,0	375	222	4	934,95
BC872900	29,0	375	230	4	997,10
BC873000	30,0	375	230	4	1.065,75
BC873100	31,0	375	239	4	1.268,67
BC873200	32,0	375	248	4	1.268,67
BC873300	33,0	375	248	4	1.482,42
BC873400	34,0	375	257	4	1.482,42
BC873500	35,0	375	257	4	1.667,13
BC873600	36,0	375	257	4	1.667,13
BC873700	37,0	375	257	4	1.884,62
BC873800	38,0	375	277	4	1.884,62
BC873900	39,0	375	277	4	2.102,30
BC874000	40,0	375	277	4	2.102,30

*Até o fim das existências.

BROCAS EM ESTOJOS DE METAL E PLÁSTICO



Ref. PT6010

Plástico Azul

- Rígido, robusto e leve.
- Janela transparente.
- Plástico reforçado com borracha anti-choque.

P Referências iniciadas por "P"
São fornecidas em uma caixa de plástico

Ref. P6011



Ref. PP6010

Metal Clássico

- Caixa metálica alta resistência.

M



Ref. DC011



Ref. DC010

Ref. BC2



Ref. BC02



BC2		Ref.	Uds.		CONTEÚDO	€
DIN 338	HSS	D0010	19	M	Ø 1-10 x 0,50 mm	64,45
		D0011	25	M	Ø 1-13 x 0,50 mm	134,09
118°	118°	P6010	19	P	Ø 1-10 x 0,50 mm	64,45
		P6011	25	P	Ø 1-13 x 0,50 mm	134,09
Quartos		AD001	37	M	Ø 1-10 x 0,25 mm	175,59
		AD002	49	M	Ø 1-13 x 0,25 mm	315,15
Décimos		D0014	50	M	Ø 1-5,90 x 0,10 mm	119,62
		D0015	41	M	Ø 6-10 x 0,10 mm	311,41
		D0022	81	M	Ø 2-10 x 0,10 mm	549,38
Mídia + Previos		D0017	23	M	Ø 1-10 x 0,50 + Ø previos*	122,85
		D0035	29	M	Ø 1-13 x 0,50 + Ø previos*	203,06
Composições Adicionais		D0007	10	M	Ø 1-10 x 1 mm	52,45
		D0009	13	M	Ø 1,5-6,5x0,5 (+3,2 & 4,8) mm	24,90
		D0008	13	M	Ø 1-7 x 0,50 mm	25,91
		D0006	12	M	Ø 2-7 x 0,50 + 8 mm	47,56

BC02		Ref.	Uds.		CONTEÚDO	€
DIN 338	Plus	DP010	19	M	Ø 1-10 x 0,50 mm	72,86
		DP011	25	M	Ø 1-13 x 0,50 mm	150,74
118°	118°	PP6010	19	P	Ø 1-10 x 0,50 mm	72,86
		PP6011	25	P	Ø 1-13 x 0,50 mm	150,74
Quartos		ADP01	37	M	Ø 1-10 x 0,25 mm	210,39
		ADP02	49	M	Ø 1-13 x 0,25 mm	374,30
Décimos		Sob demanda	50	M	Ø 1-5,90 x 0,10 mm	
		Sob demanda	41	M	Ø 6-10 x 0,10 mm	
		Sob demanda	81	M	Ø 2-10 x 0,10 mm	
Mídia + Previos		DP017	23	M	Ø 1-10 x 0,50 + Ø previos*	123,02
		DP035	29	M	Ø 1-13 x 0,50 + Ø previos*	211,63
Composições Adicionais		DP007	10	M	Ø 1-10 x 1 mm	68,82
		DP009	13	M	Ø 1,5-6,5x0,5 (+3,2 & 4,8) mm	29,28
		DP008	13	M	Ø 1-7 x 0,50 mm	29,32
		DP006	12	M	Ø 2-7 x 0,50 + 8 mm	49,21

Ref. BC5



Ref. BC18



BC5		Ref.	Uds.		CONTEÚDO	€
DIN 338	HSSCo 5%	DC010	19	M	Ø 1-10 x 0,50 mm	107,70
		DC011	25	M	Ø 1-13 x 0,50 mm	252,58
135°	135°	PC6010	19	P	Ø 1-10 x 0,50 mm	107,70
		PC6011	25	P	Ø 1-13 x 0,50 mm	252,58
Quartos		ADC01	37	M	Ø 1-10 x 0,25 mm	253,93
		ADC02	49	M	Ø 1-13 x 0,25 mm	568,31
Décimos		DC014	50	M	Ø 1-5,90 x 0,10 mm	187,11
		DC015	41	M	Ø 6-10 x 0,10 mm	461,32
		DC022	81	M	Ø 2-10 x 0,10 mm	750,64
Mídia + Previos		DC017	23	M	Ø 1-10 x 0,50 + Ø previos*	172,41
		DC035	29	M	Ø 1-13 x 0,50 + Ø previos*	330,31
Composições Adicionais		DC007	10	M	Ø 1-10 x 1 mm	89,62
		DC009	13	M	Ø 1,5-6,5x0,5 (+3,2 & 4,8) mm	43,64
		DC008	13	M	Ø 1-7 x 0,50 mm	45,72
		DC006	12	M	Ø 2-7 x 0,50 + 8 mm	68,54

BC18		Ref.	Uds.		CONTEÚDO	€
HSS	TIN	DT010	19	M	Ø 1-10 x 0,50 mm	95,13
		DT011	25	M	Ø 1-13 x 0,50 mm	208,09
118°	118°	PT6010	19	P	Ø 1-10 x 0,50 mm	95,13
		PT6011	25	P	Ø 1-13 x 0,50 mm	208,09
Quartos		ADT01	37	M	Ø 1-10 x 0,25 mm	216,82
		ADT02	49	M	Ø 1-13 x 0,25 mm	442,93
Décimos		Sob demanda	50	M	Ø 1-5,90 x 0,10 mm	
		Sob demanda	41	M	Ø 6-10 x 0,10 mm	
		Sob demanda	81	M	Ø 2-10 x 0,10 mm	
Mídia + Previos		Sob demanda	23	M	Ø 1-10 x 0,50 + Ø previos*	
		Sob demanda	29	M	Ø 1-13 x 0,50 + Ø previos*	
Composições Adicionais		DT007	10	M	Ø 1-10 x 1 mm	74,44
		DT009	13	M	Ø 1,5-6,5x0,5 (+3,2 & 4,8) mm	38,93
		DT008	13	M	Ø 1-7 x 0,50 mm	42,57
		DT006	12	M	Ø 2-7 x 0,50 + 8 mm	62,29

* Previos: de M3 a M12 (Ø3,30 - Ø4,20 - Ø6,80 - Ø10,20).

BROCAS EM ESTOJOS DE METAL E PLÁSTICO

Brocas Metal

Cinza

Rosa

Metal Clássico

- Caixa metálica alta resistência.

M

Plástico Azul

- Rígido, robusto e leve.
- Janela transparente.
- Plástico reforçado com borracha anti-choque.

P Referências iniciadas por "P"
 São fornecidos em uma caixa de plástico

Ref. PTTX011

Ref. BC95



Ref. BC58



BC95		Ref.	Uds.		CONTEÚDO	€
HSSCo 5%		DC9510	19	M	Ø 1-10 x 0,50 mm	122,78
		DC9511	25	M	Ø 1-13 x 0,50 mm	277,54
		PC9510	19	P	Ø 1-10 x 0,50 mm	122,78
		PC9511	25	P	Ø 1-13 x 0,50 mm	277,54

BC58		Ref.	Uds.		CONTEÚDO	€
DIN 338	HSSCo 8%	DC810	19	M	Ø 1-10 x 0,50 mm	155,84
		DC811	25	M	Ø 1-13 x 0,50 mm	367,65
		ADC81	37	M	Ø 1-10 x 0,25 mm	359,11
		ADC82	49	M	Ø 1-13 x 0,25 mm	842,65

Ref. BC82



BC82		Ref.	Uds.		CONTEÚDO	€
DIN 338	HSS	D8210	19	M	Ø 1-10 x 0,50 mm	64,81
		D8211	25	M	Ø 1-13 x 0,50 mm	134,09

Quartos		Ref.	Uds.		CONTEÚDO	€
		DC817	23	M	Ø 1-10 x 0,50 + Ø previos*	231,25
		DC835	29	M	Ø 1-10 x 0,50 + Ø previos*	454,71
Mídia + Previos		DC806	12	M	Ø 2-7 x 0,50 + 8 mm	90,32
Composições Adicionais		DC807	10	M	Ø 1-10 x 1 mm	113,51

Ref. BTX



BTX		Ref.	Uds.		CONTEÚDO	€
Ø ≥ 3	HSSCo 5%	PTX010	19	P	Ø 1-10 x 0,50 mm	118,13
		PTX011	25	P	Ø 1-13 x 0,50 mm	259,84

Ref. TTX



TTX		Ref.	Uds.		CONTEÚDO	€
Ø ≥ 3	HSS	PTTX010	19	P	Ø 1-10 x 0,50 mm	106,31
		PTTX011	25	P	Ø 1-13 x 0,50 mm	233,86
	TiAlSiN					

Ref. TK02



TK02		Ref.	Uds.		CONTEÚDO	€
DIN 338	HSS	TK02010	19	P	Ø 1-10 x 0,50 mm	198,38
Ø ≥ 4		TK02011	25	P	Ø 1-13 x 0,50 mm	353,91

Ref. TK05



TK05		Ref.	Uds.		CONTEÚDO	€
DIN 338	HSSCo 5%	TK05010	19	P	Ø 1-10 x 0,50 mm	247,97
Ø ≥ 5		TK05011	25	P	Ø 1-13 x 0,50 mm	442,39

BROCAS EM ESTOJOS METÁLICOS (composições especiais)

BROCAS HSS PARA ALUMÍNIO

Ref. BC16



BC16		Ref.	Uds.		CONTEÚDO	€
DIN 338	HSS	D16010	19	M	Ø 1-10 x 0,50 mm	102,04
		D16011	25	M	Ø 1-13 x 0,50 mm	223,87

BROCAS HSSCo COM GEOMETRIA TIPO "S"

Ref. BC55



BC55		Ref.	Uds.		CONTEÚDO	€
DIN 338	HSSCo 5%	D55010	18	M	Ø 1,50-10 x 0,50 mm	208,50
		D55011	24	M	Ø 1,50-13 x 0,50 mm	474,79

PONTA DE METAL DURO PARA AÇOS REFORÇADOS, FUNDIÇÃO, ETC.

Ref. BC7



BC7		Ref.	Uds.		CONTEÚDO	€
DIN 338	PMD	DPMD010	17	M	Ø 2-10 x 0,50 mm	419,43
		DPMD011	23	M	Ø 2-13 x 0,50 mm	721,74

BROCAS DE METAL DURO INTEGRAL PARA MATERIAIS MUITO DUROS

Ref. BC42



BC42		Ref.	Uds.		CONTEÚDO	€
DIN 338	MD	D42010	17	M	Ø 2-10 x 0,50 mm	1.148,36
		D42011	23	M	Ø 2-13 x 0,50 mm	2.600,00

JOGOS DE BROCAS HSSCo 8%

Ref. BC50



BC50		Ref.	Uds.		CONTEÚDO	€
DIN 338	HSSCo 5%	D50010	19	M	Ø 1-10 x 0,50 mm	363,18
		D50011	25	M	Ø 1-13 x 0,50 mm	624,54

BROCAS COM CORTE EZQUERDA



Ref. BC15



BC15		Ref.	Uds.		CONTEÚDO	€
DIN 338	HSS	D0010I	19	M	Ø 1-10 x 0,50 mm	189,56
		D0011I	25	M	Ø 1-13 x 0,50 mm	399,56
		DR9312I	10	P	Ø 1-10 x 1 mm	94,23

ESTOJOS VAZIOS

Ref.	Uds.		CONTEÚDO	€
D0010V	19	M	Ø 1-10 x 0,50 mm	19,98
D0011V	25	M	Ø 1-13 x 0,50 mm	27,87
AD001V	37	M	Ø 1-10 x 0,25 mm	73,21
AD002V	49	M	Ø 1-13 x 0,25 mm	85,03
D0014V	50	M	Ø 1-5,9 x 0,10 mm	64,85
D0015V	41	M	Ø 6-10 x 0,10 mm	129,57
D0022V	81	M	Ø 2-10 x 0,10 mm	248,50
D0006V	12	M	Ø 2-7 x 0,50 + 8 mm	27,11
D0007V	10	M	Ø 1-10 x 1 mm	46,50
D0017V	23	M	Ø 1-10 x 0,50 mm + previos*	53,95
D0035V	29	M	Ø 1-13 x 0,50 mm + previos*	76,30
DE10V	19	M	Ø 1-10 x 0,50 mm	47,19
DE11V	25	M	Ø 1-13 x 0,50 mm	57,65

DIN 1897



BROCAS EM ESTOJOS DE METAL
BROCAS SERIE LONGA DIN 340

Ref. BC4



BC4		Ref.	Uds.	CONTEÚDO	€	
DIN 340	HSS	D0004	19	M	Ø 1-10 x 0,50 mm	111,36

Ref. BC47



BC47		Ref.	Uds.	CONTEÚDO	€	
DIN 340	HSSCo 5%	DC004	x17	M	Ø 2-10 x 0,50 mm	237,09

Ref. BC40



BC40		Ref.	Uds.	CONTEÚDO	€	
HSS	TiN	DT004	19	M	Ø 1-10 x 0,50 mm	171,55

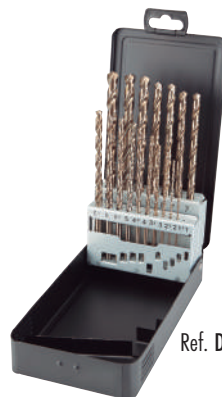

Ref. DC004



Ref. DT004

BROCAS SERIE EXTRA-CURTA

Ref. BC3



BC3		Ref.	Uds.	CONTEÚDO	€	
DIN 1897	HSS	D3010	19	M	Ø 1-10 x 0,50 mm	74,88
		D3011	25	M	Ø 1-13 x 0,50 mm	143,58

Ref. BC31



BC31		Ref.	Uds.	CONTEÚDO	€	
DIN 1897	HSSCo 5%	D3110	19	M	Ø 1-10 x 0,50 mm	112,26
		D3111	25	M	Ø 1-13 x 0,50 mm	235,88

Ref. BC33



BC33		Ref.	Uds.	CONTEÚDO	€	
DIN 1897	HSSCo 5%	D3310	19	M	Ø 1-10 x 0,50 mm	204,61
		D3311	25	M	Ø 1-13 x 0,50 mm	370,30

Ref. BC77



BC77		Ref.	Uds.	CONTEÚDO	€	
DIN 1897	PMD	D7710	17	M	Ø 2-10 x 0,50 mm	520,36
		D7711	23	M	Ø 2-13 x 0,50 mm	871,16

Ref. BC43



BC43		Ref.	Uds.	CONTEÚDO	€	
DIN 1897	MD	D4310	17	M	Ø 2-10 x 0,50 mm	774,09
		D4311	23	M	Ø 2-13 x 0,50 mm	1.645,87



Ref. D7710



Ref. D3110

BROCAS EM ESTOJOS DE PLÁSTICO



Ref. DP9314



Ref. DP9312



Ref. DP9313



Ref. DP9311

Ref. BC2



BC2		Ref.	Uds.	CONTEÚDO	€
DIN 338	HSS	DR9314	6	Ø 2 - 3 - 4 - 5 - 6 - 8 mm	18,76
		DR9312	10	Ø 1-10 x 1 mm	39,93
		DR9313	13	Ø 2-8 x 0,50 mm	39,62
		DR9311	19	Ø 1-10 x 0,50 mm	69,76

Ref. BC02



BC02		Ref.	Uds.	CONTEÚDO	€
DIN 338	Plus	DP9314	6	Ø 2 - 3 - 4 - 5 - 6 - 8 mm	19,77
		DP9312	10	Ø 1-10 x 1 mm	43,24
		DP9313	13	Ø 2-8 x 0,50 mm	42,25
		DP9311	19	Ø 1-10 x 0,50 mm	76,26

Ref. BC5



BC5		Ref.	Uds.	CONTEÚDO	€
DIN 338	HSSCo 5%	DC9314	6	Ø 2 - 3 - 4 - 5 - 6 - 8 mm	29,81
		DC9312	10	Ø 1-10 x 1 mm	63,93
		DC9313	13	Ø 2-8 x 0,50 mm	64,41
		DC9311	19	Ø 1-10 x 0,50 mm	114,28

Ref. BC18



BC18		Ref.	Uds.	CONTEÚDO	€
HSS	TiN	DT9314	6	Ø 2 - 3 - 4 - 5 - 6 - 8 mm	20,54
		DT9312	10	Ø 1-10 x 1 mm	43,74
		DT9313	13	Ø 2-8 x 0,50 mm	43,40
		DT9311	19	Ø 1-10 x 0,50 mm	76,41

Ref. BC82



BC82		Ref.	Uds.	CONTEÚDO	€
DIN 338	HSS	D829314	6	Ø 2 - 3 - 4 - 5 - 6 - 8 mm	17,76
		D829312	10	Ø 1-10 x 1 mm	37,79
		D829313	13	Ø 2-8 x 0,50 mm	37,49
		D829311	19	Ø 1-10 x 0,50 mm	66,02

Ref. BC58



BC58		Ref.	Uds.	CONTEÚDO	€
DIN 338	HSSCo 8%	D89314	6	Ø 2 - 3 - 4 - 5 - 6 - 8 mm	38,04
		D89312	10	Ø 1-10 x 1 mm	81,35
		D89313	13	Ø 2-8 x 0,50 mm	83,38
		D89311	19	Ø 1-10 x 0,50 mm	146,26

								€
BC95	HSSCo 5%	OX DOURADO			DC959314	6	Ø 2-3-4-5-6-8 mm	29,92
BTX		HSSCo 5%		DOURADO	PTX9314	6	Ø 2-3-4-5-6-8 mm	29,65
TTX		HSS		TiAlSiN	PTTX9314	6	Ø 2-3-4-5-6-8 mm	27,62
TK02	DIN 338	HSS			PTK029314	6	Ø 2-3-4-5-6-8 mm	48,83
TK05	DIN 338	HSSCo 5%			PTK059314	6	Ø 2-3-4-5-6-8 mm	61,04

Ref. BC95



Ref. BTX



Ref. TTX



Ref. TK02



Ref. TK05



BROCAS EM ESTOJOS DE PLÁSTICO
LATAS CLASSIFICADORAS DE PLÁSTICO COM 19 PEÇAS

					Ref.	Uds.	CONTEÚDO	€
BC2	DIN 338	HSS	118°		DR9380	19	Ø 1-10 x 0,50 mm	65,43
BC02	DIN 338	Plus	118°		DP9380	19	Ø 1-10 x 0,50 mm	73,34
BC5	DIN 338	HSSCo 5%	135°		DC9380	19	Ø 1-10 x 0,50 mm	109,08
BC18	TiN	HSS	118°		DT9380	19	Ø 1-10 x 0,50 mm	96,94
BC58	DIN 338	HSSCo 8%	135°		D89380	19	Ø 1-10 x 0,50 mm	148,35

Ref. BC2



Ref. BC02



Ref. BC5



Ref. BC18

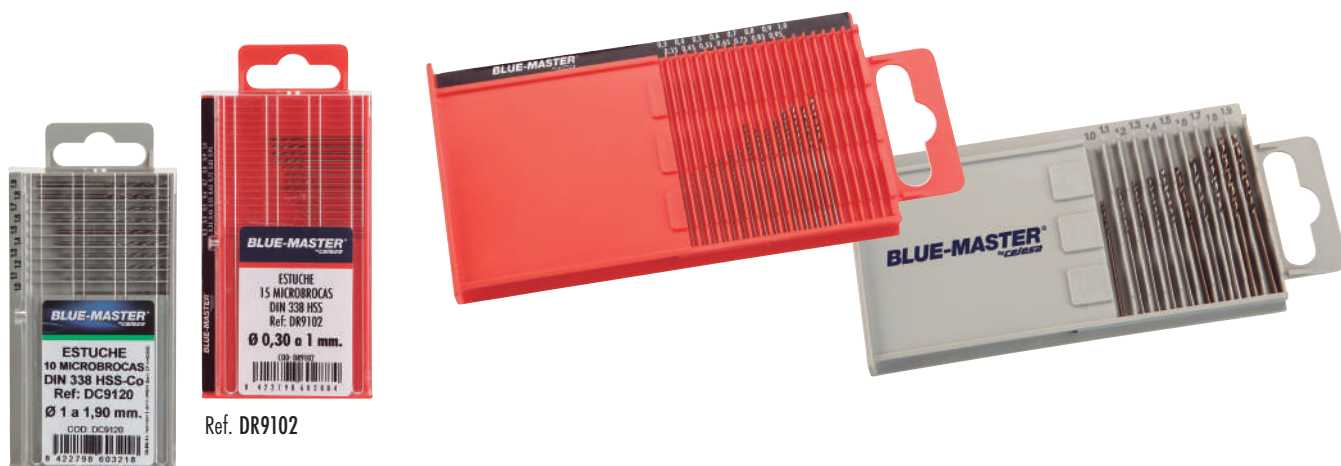

Ref. BC58

JOGOS DE BROCAS RETIFICADAS EM ESTOJOS DE PLÁSTICO MICRO-BROCAS, AEROMODELISMO E MARCHETARIA

Ref. DR9102

Ref. DC9120

				Ref.	Uds.	CONTEÚDO	€
DR9120	DIN 338	HSS		DR9120	10	Ø 1-1,90 x 0,10 mm	25,16
DC9120	DIN 338	HSSCo 5%		DC9120	10	Ø 1-1,90 x 0,10 mm	37,95
DR9102	DIN 338	HSS		DR9102	15	Ø 0,30 - 0,35 - 0,40 - 0,45 - 0,50 - 0,55 - 0,60 - 0,65 - 0,70 - 0,75 - 0,80 - 0,85 - 0,90 - 0,95 - 1	50,47

ESTOJOS DE PLÁSTICO MISTOS: HSS, WIDIA E MADEIRA

SERIE STANDARD

HSS		(Ref. BC2)	  	
PMD		(Ref. BW1)		
CV		(Ref. BM)		
REFERÊNCIA	EC9330		EC9331	EC9332
Nº BROCAS	8		9	9
QUALIDADE				
CONTEÚDO	Ø 4 - 5 - 6 - 8 mm x 2		Ø 4 - 6 - 8 mm x 3	Ø 5 - 6 - 8 mm x 3
P.V.P. €	24,08		25,66	26,16

*Até o fim das existências.

SERIE PROFESSIONAL

HSSCo 5%		(Ref. BC5)	   		
PMD		(Ref. BW6)			
HSS		(Ref. Bmpr)			
REFERÊNCIA	M9330		M9331	M9332	M9382
Nº BROCAS	8		9	9	18
QUALIDADE					
CONTEÚDO	Ø 4 - 5 - 6 - 8 mm x 2		Ø 4 - 6 - 8 mm x 3	Ø 5 - 6 - 8 mm x 3	Ø 3 - 4 - 5 - 6 - 8 - 10 mm x 3
P.V.P. €	41,60		40,85	41,68	81,50*

*Até o fim das existências.

SERIE EXTRA-PROFISSIONAL

HSSCo 5%		(Ref. BC5)	   		
PMD		(Ref. BW15)			
HSS		(Ref. Bmpr)			
REFERÊNCIA	P9330		P9331	P9332	P9382
Nº BROCAS	8		9	9	18
QUALIDADE					
CONTEÚDO	Ø 4 - 5 - 6 - 8 mm x 2		Ø 4 - 6 - 8 mm x 3	Ø 5 - 6 - 8 mm x 3	Ø 3 - 4 - 5 - 6 - 8 - 10 mm x 3
P.V.P. €	61,76*		56,36*	57,41*	114,71*

*Até o fim das existências.

ARMÁRIOS EXPOSITORES PARA APRESENTAÇÃO DE BROCAS CILÍNDRICAS DIN 338

Brocas Metal

Cinza

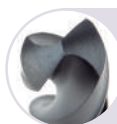
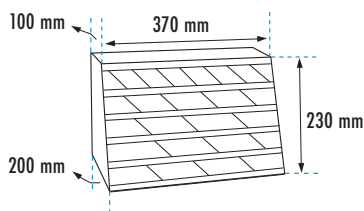

Ref. BC2

DIN 338

HSS



OX



HSS

CONTEÚDO 400 BROCAS

Brocas BC2

1,00	1,50	2,00	2,50	3,00	3,50	4,00	4,50	5,00	5,50	6,00	6,50	7,00
10	10	20	20	50	30	40	20	40	10	30	10	10
7,50	8,00	8,50	9,00	9,50	10,00	10,50	11,00	11,50	12,00	12,50	13,00	
10	20	10	10	10	10	5	5	5	5	5	5	

EXPBROCASBC2

1.287,80 €



Ref. BC02

DIN 338

HSS-G Plus



OX DOURADO



CONTEÚDO 316 BROCAS

Brocas BC02

1,00	1,50	2,00	2,50	3,00	3,50	4,00	4,50	5,00	5,50	6,00	6,50	7,00
10	10	20	10	20	10	30	10	30	10	30	10	10
7,50	8,00	8,50	9,00	9,50	10,00	10,50	11,00	11,50	12,00	12,50	13,00	
10	20	10	10	10	10	6	6	6	6	6	6	

EXPBROCASBC02

1.370,60 €

ARMÁRIOS EXPOSITORES PARA APRESENTAÇÃO DE BROCAS CILÍNDRICAS DIN 338



EXPBROCASBC5
1.782,40 €



Ref. BC5

DIN 338

HSSCo 5%



DOURADO

120 Kg/mm²



HSSCo 5%



CONTEÚDO 220 BROCAS

Brocas BC5

1,00 10	1,50 10	2,00 10	2,50 10	3,00 10	3,50 10	4,00 10	4,50 10	5,00 10	5,50 10	6,00 10	6,50 10	7,00 10
7,50 10	8,00 10	8,50 10	9,00 10	9,50 10	10,00 10	10,50 5	11,00 5	11,50 5	12,00 5	12,50 5	13,00 5	



Ref. BC18

DIN 338

HSS



TiN



HSS

TiN



CONTEÚDO 200 BROCAS

Brocas BC18

1,00 10	1,50 10	2,00 10	2,50 10	3,00 10	3,50 10	4,00 10	4,50 10	5,00 10	5,50 10	6,00 10	6,50 10	7,00 10
7,50 10	8,00 10	8,50 5	9,00 5	9,50 5	10,00 5	10,50 5	11,00 5	11,50 5	12,00 5	12,50 5	13,00 5	



EXPBROCASBC18
1.323,45 €

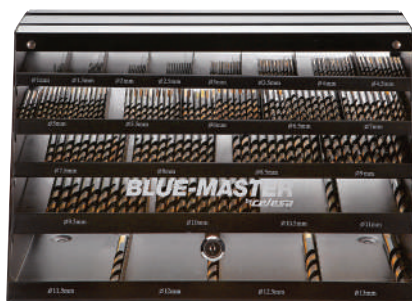

EXPBROCASBC95
1.145,60 €



Ref. BC95

DIN 338

HSSCo 5%



OX DOURADO

INOX



HSSCo 5%



CONTEÚDO 176 BROCAS

Brocas BC95

1,00 10	1,50 10	2,00 10	2,50 10	3,00 10	3,50 10	4,00 10	4,50 10	5,00 10	5,50 10	6,00 10	6,50 10	7,00 10
7,50 10	8,00 10	8,50 5	9,00 5	9,50 5	10,00 5	10,50 1	11,00 1	11,50 1	12,00 1	12,50 1	13,00 1	

ARMÁRIOS EXPOSITORES PARA APRESENTAÇÃO DE BROCAS CILÍNDRICAS DIN 338

Ref. BTX

**DIN
338**
**HSSCo
5%**

DOURADO

**HSSCo
5%**

CONTEÚDO 176 BROCAS

Brocas BC5 (Ø1-2,5mm) Brocas BTX (Ø3-13mm)

<u>1,00</u> 10	<u>1,50</u> 10	<u>2,00</u> 10	<u>2,50</u> 10	<u>3,00</u> 10	<u>3,50</u> 10	<u>4,00</u> 10	<u>4,50</u> 10	<u>5,00</u> 10	<u>5,50</u> 10	<u>6,00</u> 10	<u>6,50</u> 10	<u>7,00</u> 10
<u>7,50</u> 10	<u>8,00</u> 10	<u>8,50</u> 5	<u>9,00</u> 5	<u>9,50</u> 5	<u>10,00</u> 5	<u>10,50</u> 1	<u>11,00</u> 1	<u>11,50</u> 1	<u>12,00</u> 1	<u>12,50</u> 1	<u>13,00</u> 1	

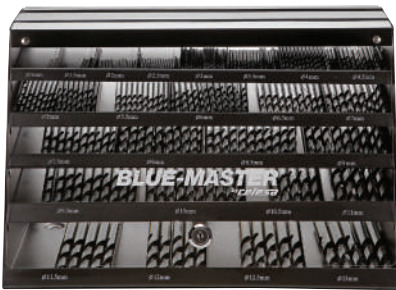
EXPBROCASBTX
103,90 €
EXPBROCASBTX
970,91 €

Ref. TK02

**DIN
338**
HSS

Al

Cu-Ni-Zn

PVC

STEP CUT

HSS

CONTEÚDO 176 BROCAS

Brocas TK02

<u>1,00</u> 10	<u>1,50</u> 10	<u>2,00</u> 10	<u>2,50</u> 10	<u>3,00</u> 10	<u>3,50</u> 10	<u>4,00</u> 10	<u>4,50</u> 10	<u>5,00</u> 10	<u>5,50</u> 10	<u>6,00</u> 10	<u>6,50</u> 10	<u>7,00</u> 10
<u>7,50</u> 10	<u>8,00</u> 10	<u>8,50</u> 5	<u>9,00</u> 5	<u>9,50</u> 5	<u>10,00</u> 5	<u>10,50</u> 1	<u>11,00</u> 1	<u>11,50</u> 1	<u>12,00</u> 1	<u>12,50</u> 1	<u>13,00</u> 1	

EXPBROCASTK02
1.724,78 €

Ref. TK05

**DIN
338**
**HSSCo
5%**

INOX

FUNDAÇÃO

Cu-Ni-Zn

PVC

STEP CUT

**HSSCo
5%**

CONTEÚDO 176 BROCAS

Brocas TK05

<u>1,00</u> 10	<u>1,50</u> 10	<u>2,00</u> 10	<u>2,50</u> 10	<u>3,00</u> 10	<u>3,50</u> 10	<u>4,00</u> 10	<u>4,50</u> 10	<u>5,00</u> 10	<u>5,50</u> 10	<u>6,00</u> 10	<u>6,50</u> 10	<u>7,00</u> 10
<u>7,50</u> 10	<u>8,00</u> 10	<u>8,50</u> 5	<u>9,00</u> 5	<u>9,50</u> 5	<u>10,00</u> 5	<u>10,50</u> 1	<u>11,00</u> 1	<u>11,50</u> 1	<u>12,00</u> 1	<u>12,50</u> 1	<u>13,00</u> 1	

EXPBROCASTK05
2.181,38 €

MALAS METÁLICAS DE BROCAS RETIFICADAS



DIN 338

125 BROCAS Ø 1-10 mm x 0,50

Ø	1	1,50	2	2,50	3	3,50	4	4,50
Cont.	10	5	10	5	10	5	10	5
	5	5,50	6	6,50	7	7,50	8	8,50
	10	5	10	5	5	5	5	5
	9	9,50	10	= 125 BROCAS				
	5	5	5					



REFERÊNCIA	BC2880	BC02880	BC5880	BC18880	M0880V
Nº BROCAS	125	125	125	125	250
QUALIDADE	HSS	Plus	HSSCo 5%	HSS TiN	
CONTEÚDO	Ø 1-10 x 0,50 S/DETALHE	Ø 1-10 x 0,50 S/DETALHE	Ø 1-10 x 0,50 S/DETALHE	Ø 1-10 x 0,50 S/DETALHE	ESTOJO VAZIO
P.V.P. €	410,78	460,47	679,99	563,93	159,26



DIN 338

155 BROCAS Ø 1-13 mm x 0,50

Ø	1	1,50	2	2,50	3	3,50	4	4,50	5
Cont.	10	5	10	5	10	5	10	5	10
	5,50	6	6,50	7	7,50	8	8,50	9	9,50
	5	10	5	5	5	5	5	5	5
	10	10,50	11	11,50	12	12,50	13	=155 BROCAS	
	5	5	5	5	5	5	5		



REFERÊNCIA	BC2881	BC02881	BC5881	BC18881	M0881V
Nº BROCAS	155	155	155	155	290
QUALIDADE	HSS	Plus	HSSCo 5%	HSS TiN	
CONTEÚDO	Ø 1-13 x 0,50 S/DETALHE	Ø 1-13 x 0,50 S/DETALHE	Ø 1-13 x 0,50 S/DETALHE	Ø 1-13 x 0,50 S/DETALHE	ESTOJO VAZIO
P.V.P. €	825,10	917,07	1.464,21	1.148,89	368,78

MALAS METÁLICAS DE BROCAS CÔNICAS DIN 345

DIN 345

HSS



(Brocas Ref. BC11)

REFERÊNCIA	MBC11-1	MBC11-2
Nº BROCAS	10	10
QUALIDADE	HSS	HSS
CONTEÚDO	Ø 14 - 15 - 16 - 17 - 18 - 19 - 20 - 21 - 22 - 23	Ø 14 - 16 - 18 - 20 - 22 - 24 - 25 - 26 - 28 - 30
P.V.P. €	722,49	1.007,94

TABELA DE CONSULTA DAS VELOCIDADES E AVANÇOS PARA BROCAS

			Diâmetro Ø (mm)											
			2	3	5	7	10	12	15	18	20	22	25	30
AÇO MOLE 70 kg/mm ² BC2	V/C 25 m/min	RPM	3979	2653	1592	1137	796	663	531	442	398	362	318	265
		mm / volta	0,04	0,06	0,08	0,15	0,20	0,26	0,30	0,33	0,34	0,35	0,35	0,39
		S (mm / min)	159	159	127	171	159	172	159	146	135	127	111	103
AÇO TRATADO 120 kg/mm ² BC5	V/C 13 m/min	RPM	2069	1379	828	591	414	345	276	230	207	188	166	138
		mm / volta	0,03	0,045	0,06	0,10	0,15	0,18	0,20	0,22	0,23	0,25	0,25	0,28
		S (mm / min)	62	62	50	59	62	60	55	51	48	47	41	39
INOXIDÁVEL BC50	V/C 11 m/min	RPM	1751	1167	700	500	350	292	233	195	175	159	140	117
		mm / volta	0,02	0,05	0,08	0,14	0,19	0,23	0,25	0,27	0,28	0,30	0,31	0,33
		S (mm / min)	35	58	56	70	67	67	58	53	49	48	43	39
ALUMÍNIO BC16	V/C 50 m/min	RPM	7958	5305	3183	2274	1592	1326	1061	884	796	723	637	531
		mm / volta	0,03	0,06	0,08	0,16	0,20	0,23	0,25	0,28	0,29	0,30	0,30	0,36
		S (mm / min)	239	318	255	364	318	305	265	248	231	217	191	191
TITÂNIO BC42	V/C 18 m/min	RPM	5570	3714	2228	1592	1114	928	743	619	557	506	446	371
		mm / volta	0,02	0,03	0,03	0,05	0,08	0,08	0,12	0,15				
		S (mm / min)	111	111	67	80	84	74	89	93				
FUNDIÇÃO BC7	V/C 25 m/min	RPM	3979	2653	1592	1137	796	663	531	442	398	362	318	265
		mm / volta	0,05	0,08	0,10	0,20	0,27	0,31	0,37	0,41	0,42	0,42	0,42	0,45
		S (mm / min)	199	199	159	227	215	206	196	181	167	152	134	119
LATÃO BC66	V/C 50 m/min	RPM	7958	5305	3183	2274	1592	1326	1061	884	796	723	637	531
		mm / volta	0,04	0,07	0,08	0,17	0,21	0,25	0,28	0,28	0,30	0,30	0,33	0,40
		S (mm / min)	318	345	239	387	334	332	297	248	239	217	210	212
PLÁSTICO FIBRA DE CARBONO BC7	V/C 12 m/min	RPM	1911	1274	764	546	382	318	255	212	191	174	153	127
		mm / volta	0,02	0,03	0,03	0,05	0,08	0,08	0,12	0,15				
		S (mm / min)	38	38	23	27	29	25	31	32				
LIGAS NI BC42	V/C 30 m/min	RPM	4775	3183	1910	1364	955	796	637	531	477	434	382	318
		mm / volta	0,015	0,02	0,02	0,03	0,04	0,06	0,07	0,08	0,11	0,12	0,15	
		S (mm / min)	72	64	42	34	38	48	45	42	53	52	57	
CIRCUITOS IMPRESSOS BC79	25	RPM	3979	-	-	-	-	-	-	-	-	-	-	

OBSERVAÇÕES:

- Conhecidos o diâmetro da broca e o material a furar, a velocidade e o avanço identificam-se rapidamente. Exemplo:

MATERIAL: ALUMÍNIO

RPM=2274

Ø de broca: 7 mm

S=364 mm/min

- Depois de fazer os primeiros furos é preciso ajustar tanto a velocidade como o avanço.

INFORMAÇÃO TÉCNICA SOBRE AS DIMENSÕES DE CONES MORSE

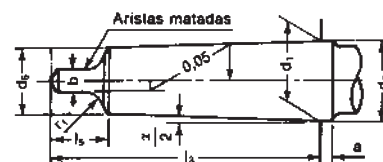

CONE MORSE	Afinamento	Ø 2	a	b h13	d ₁	d ₂ Ø maior =	d ₆ Ø maior =	d ₇ Dimen. máx.	l ₃ -1	l ₄ Dimen. máx.	l ₅ Dimen. máx.	r ₁	r ₂
0	1:19,212=0,05205	1°29' 27"	3,0	3,9	9,045	9,2	6,1	6,0	56,5	59,5	10,5	4	1,0
1	1:20,047=0,04988	1°25' 43"	3,5	5,2	12,065	12,2	9,0	8,7	62,0	65,5	13,5	5	1,2
2	1:20,020=0,04995	1°25' 50"	5,0	6,3	17,780	18,0	14,0	13,5	75,0	80,0	16,0	6	1,6
3	1:19,922=0,05020	1°26' 16"	5,0	7,0	23,825	24,1	19,1	18,5	94,0	99,0	20,0	7	2,0
4	1:19,254=0,05194	1°29' 15"	6,5	11,9	31,267	31,6	25,2	24,5	117,5	124,0	24,0	8	2,5
5	1:19,002=0,05263	1°30' 26"	6,5	15,9	44,399	44,7	36,5	35,7	149,5	156,0	29,0	10	3,0
6	1:19,180=0,05214	1°29' 36"	8,0	19,0	63,348	63,8	52,4	51,0	210,0	218,0	40,0	10	4,0