

BLUE-MASTER®
by *celesa*



PUNTE
PER METALLO

PUNTE ELICOIDALI CILINDRICHE DIN 338



10 U. Ø 0,20 - Ø 10,50 mm

6 U. Ø 10,60 - Ø 14 mm

1 U. Ø 14,10 - Ø 20 mm

1 U. BC9-BC99
BC7-BC98-BC42



	BTX	TTX	BC51	BC95	BC55	BC57	BC50	BC7	BC98	BC42
MATERIALE	HSSCo 5%	HSS	HSSCo 5%	HSSCo 5%	HSSCo 5%	HSSCo 5%	HSSCo 5%	PMD	PMD	MD
TIPO DI AFFILATURA										
ANGOLO DI TAGLIO	135°	135°	135°	130°	135°	135°	118°	118°	135°	135°
ELICA	38° "5"	38° "5"	30° "N"	Ø ≥ 3	38° "5"	38° "5"	38° "N"	30° "N"	30° "N"	35° "N"
FINITURA	DORATO	TiAlSiN	TiAlN	DORATO OX	BRILLANTE	TiAlN	TiAlN	BRILLANTE	BRILLANTE	BRILLANTE
APPLICAZIONE										
Ø mm	L1 x L2	€	€	€	€	€	€	€	€	€
0,20	19 x 2,50									
0,25	19 x 3									
0,30	19 x 3									
0,35	19 x 4									
0,40	20 x 5									
0,45	20 x 5									
0,50	22 x 6									13,53
0,55	24 x 7									
0,60	24 x 7									
0,65	26 x 8									
0,70	28 x 9									
0,75	28 x 9									
0,80	30 x 10									
0,85	30 x 10									
0,90	32 x 11									
0,95	32 x 11									
1,00	34 x 12		3,57	3,01	3,64	6,04				9,06
1,05	34 x 12									
1,10	36 x 14									9,12
1,15	36 x 14									
1,19	3/64"									
1,20	38 x 16				4,75	5,80				9,12
1,25	38 x 16									
1,30	38 x 16									9,12
1,35	40 x 18									
1,40	40 x 18									9,12
1,45	40 x 18									
1,50	40 x 18		3,37	2,86	2,96	6,03				9,28
1,55	43 x 20									

Punte Metallo

Rosa

Ø 0,20-1,5mm

PUNTE ELICOIDALI CILINDRICI DIN 338

Punte Metallo

Grigio

Rosso

**DIN
338**

		BC2	BC82	BC02	BC9	BC5	BC99	BC58	BC16	BC66	BC15	BC18
MATERIALE		HSS	HSS	HSS-G	HSS	HSSCo 5%	HSSCo 5%	HSSCo 8%	HSS	HSS	HSS	HSS
TIPO DI AFFILATURA												
ANGOLO DI TAGLIO		118°	118°	118°	118°	135°	135°	135°	135°	118°	118°	118°
ELICA		30° "N"	30° "N"	30° "N"	30° "N"	30° "N"	30° "N"	30° "N"	40° "W"	15° "H"	30° "N"	30° "N"
FINITURA		OX	BRILLANTE	DORATO OX	OX	DORATO	DORATO	DORATO	BRILLANTE	BRILLANTE	OX	TiN
APPLICAZIONE												
Ø mm	L1 x L2	€	€	€	€	€	€	€	€	€	€	€
1,59	1/16"	1,41				2,89						
1,60	43 x 20	1,56	1,56			2,79						2,33
1,65	43 x 20	1,56	1,56									
1,70	43 x 20	1,56	1,56			2,79						2,32
1,75	46 x 22	1,40	1,40			3,02		4,50	2,80	4,55		2,22
1,80	46 x 22	1,38	1,38			2,73						2,18
1,85	46 x 22	1,38	1,38									
1,90	46 x 22	1,38	1,38			3,04						2,18
1,95	48 x 24	1,38										
1,98	5/64"	1,27				3,03						
2,00	49 x 24	1,17	1,17	1,39		2,27		3,73	2,30	2,69	2,67	1,79
2,05	49 x 24	1,28	1,28									
2,10	49 x 24	1,28	1,28			3,14						2,19
2,15	53 x 27	1,28										
2,20	53 x 27	1,28	1,28			3,14						2,18
2,25	53 x 27	1,21	1,21	1,48		2,99		4,50	2,78	3,11		2,10
2,30	53 x 27	1,48	1,48			3,14						2,33
2,35	53 x 27	1,48	1,48									
2,38	3/32"	1,41				2,98						
2,40	57 x 30	1,48	1,48			3,14						2,33
2,45	57 x 30	1,48										
2,50	57 x 30	1,26	1,26	1,56		2,34		3,56	2,31	2,72	2,67	1,88
2,55	57 x 30	1,52	1,52									
2,60	57 x 30	1,52	1,52			3,03						2,32
2,65	57 x 30	1,52										
2,70	61 x 33	1,52	1,52	1,88		3,03						2,32
2,75	61 x 33	1,33	1,33	1,60		2,99		3,85	2,78	3,65		2,26
2,78	7/64"	1,44				2,89						
2,80	61 x 33	1,52	1,52	1,88		3,04						2,32

PUNTE ELICOIDALI CILINDRICI DIN 338



- 10 U. Ø 0,20 - Ø 10,50 mm
- 6 U. Ø 10,60 - Ø 14 mm
- 1 U. Ø 14,10 - Ø 20 mm
- BC9-BC99
BC7-BC98-BC42



		BTX	TTX	BC51	BC95	BC55	BC57	BC50	BC7	BC98	BC42
MATERIALE		HSSCo 5%	HSS	HSSCo 5%	HSSCo 5%	HSSCo 5%	HSSCo 5%	HSSCo 5%	PMD	PMD	MD
TIPO DI AFFILATURA											
ANGOLO DI TAGLIO		135°	135°	135°	130°	135°	135°	118°	118°	135°	135°
ELICA		38° "S"	38° "S"	30° "N"	Ø ≥ 3	38° "S"	38° "S"	38° "N"	30° "N"	30° "N"	35° "N"
FINITURA		DORATO	TiAlSiN	TiAlN	DORATO OX	BRILLANTE	TiAlN	TiAlN	BRILLANTE	BRILLANTE	BRILLANTE
APPLICAZIONE		120 Kg/mm²	80 Kg/mm²	ALTA PRODUZIONE	INOX	INOX	INOX	INOX Plus	GHISA	70 Hrc	ALTA PRODUZIONE
Ø mm	L1 x L2	€	€	€	€	€	€	€	€	€	€
1,59	1/16"										
1,60	43 x 20					3,09					9,84
1,65	43 x 20										
1,70	43 x 20					2,80					10,18
1,75	46 x 22				2,86						
1,80	46 x 22					2,96	5,95				10,56
1,85	46 x 22										
1,90	46 x 22					3,24					11,44
1,95	48 x 24										
1,98	5/64"										
2,00	49 x 24			3,52	2,86	3,12	5,68	6,02	19,11		11,76
2,05	49 x 24										
2,10	49 x 24					3,94			20,75		15,37
2,15	53 x 27										
2,20	53 x 27					3,75	6,42		20,75		16,51
2,25	53 x 27				2,86				20,75		
2,30	53 x 27					3,73			20,75		16,51
2,35	53 x 27										
2,38	3/32"										
2,40	57 x 30					4,50			20,75		16,82
2,45	57 x 30										
2,50	57 x 30			3,53	2,86	3,06	6,81	6,70	19,11		14,37
2,55	57 x 30										
2,60	57 x 30					3,37			20,75		20,74
2,65	57 x 30										
2,70	61 x 33										
2,75	61 x 33			3,67	2,86	3,01			20,75		20,74
2,78	7/64"								20,75		
2,80	61 x 33					3,13	8,56		20,75		20,74

Punte Metallo
Rosa

Ø 1,59-2,80mm

PUNTE ELICOIDALI CILINDRICI DIN 338

Punte Metallo

Grigio

Rosso

**DIN
338**

		BC2	BC82	BC02	BC9	BC5	BC99	BC58	BC16	BC66	BC15	BC18
MATERIALE		HSS	HSS	HSS-G	HSS	HSSCo 5%	HSSCo 5%	HSSCo 8%	HSS	HSS	HSS	HSS
TIPO DI AFFILATURA												
ANGOLO DI TAGLIO		118°	118°	118°	118°	135°	135°	135°	135°	118°	118°	118°
ELICA		30° "N"	30° "N"	30° "N"	30° "N"	30° "N"	30° "N"	30° "N"	40° "W"	15° "H"	30° "N"	30° "N"
FINITURA		OX	BRILLANTE	DORATO OX	OX	DORATO	DORATO	DORATO	BRILLANTE	BRILLANTE	OX	TiN
APPLICAZIONE				Plus					Al	OTTONE		PRODUZIONE
Ø mm	L1 x L2	€	€	€	€	€	€	€	€	€	€	€
2,85	61 x 33	1,53										
2,90	61 x 33	1,52	1,52			3,03						2,32
2,95	61 x 33	1,69										
3,00	61 x 33	1,27	1,27	1,39		2,28		3,44	2,28	2,99	2,38	1,79
3,05	65 x 36	1,66										
3,10	65 x 36	1,48	1,48	1,59		2,93		4,84				2,27
3,15	65 x 36	1,66										
3,17	1/8"	1,40				2,77						
3,20	65 x 36	1,48	1,48	1,59		2,90		4,84	2,78			2,27
3,25	65 x 36	1,48	1,48	1,59		2,93		4,44	2,78	3,65		2,58
3,30	65 x 36	1,48	1,48	1,59		2,90		4,84	2,78			2,27
3,35	65 x 36	1,88										
3,40	70 x 39	1,88	1,88	2,09		3,04						2,79
3,45	70 x 39	1,90										
3,50	70 x 39	1,43	1,43	1,59		2,90		4,36	2,73	3,24	2,95	2,32
3,55	70 x 39	1,98										
3,57	9/64"	1,85				3,47						
3,60	70 x 39	1,98	1,98	2,19		3,65						2,58
3,65	70 x 39	1,98										
3,70	70 x 39	1,98	1,98	2,19		3,65						2,58
3,75	70 x 39	1,66	1,66	1,88		3,46		5,27	3,40	4,75		2,73
3,80	75 x 43	2,03	2,03	2,31		3,65						2,59
3,85	75 x 43	2,04										
3,90	75 x 43	2,02	2,02	2,31		3,65						2,58
3,95	75 x 43	2,02										
3,97	5/32"	1,91				3,47						
4,00	75 x 43	1,59	1,59	1,83		3,09		4,71	2,96	3,48	3,00	2,50
4,05	75 x 43	2,02										
4,10	75 x 43	1,82	1,82	2,02		3,46		5,81	3,35			2,80

PUNTE ELICOIDALI CILINDRICI DIN 338



- 10 U.** Ø 0,20 - Ø 10,50 mm
- 6 U.** Ø 10,60 - Ø 14 mm
- 1 U.** Ø 14,10 - Ø 20 mm
- 1 U.** BC9-BC99
BC7-BC98-BC42



		BTX	TTX	BC51	BC95	BC55	BC57	BC50	BC7	BC98	BC42
MATERIALE		HSSCo 5%	HSS	HSSCo 5%	HSSCo 5%	HSSCo 5%	HSSCo 5%	HSSCo 5%	PMD	PMD	MD
TIPO DI AFFILATURA											
ANGOLO DI TAGLIO		135°	135°	135°	130°	135°	135°	118°	118°	135°	135°
ELICA		38° "S"	38° "S"	30° "N"	Ø ≥ 3	38° "S"	38° "S"	38° "N"	30° "N"	30° "N"	35° "N"
FINITURA		DORATO	TiAlSiN	TiAlN	DORATO OX	BRILLANTE	TiAlN	TiAlN	BRILLANTE	BRILLANTE	BRILLANTE
APPLICAZIONE											
Ø mm	L1 x L2	€	€	€	€	€	€	€	€	€	€
2,85	61 x 33										
2,90	61 x 33					3,16			20,75		20,74
2,95	61 x 33										
3,00	61 x 33	2,48	2,35	3,45	2,80	2,31	5,56	6,71	17,52	15,41	15,13
3,05	65 x 36										
3,10	65 x 36					2,38	6,84		19,84		20,18
3,15	65 x 36										
3,17	1/8"										
3,20	65 x 36	3,03	2,87		3,47	2,38	6,89		19,84		20,18
3,25	65 x 36				3,47				19,84		
3,30	65 x 36	3,04	2,88	4,32	3,48	2,84	6,92	8,15	19,84	17,43	18,07
3,35	65 x 36										
3,40	70 x 39					2,89			19,84		22,11
3,45	70 x 39										
3,50	70 x 39	2,98	2,83	4,35	3,38	3,00	6,87	7,81	18,29	16,08	18,98
3,55	70 x 39										
3,57	9/64"										
3,60	70 x 39					3,14			19,84	17,43	23,19
3,65	70 x 39										
3,70	70 x 39					3,04			19,84		23,19
3,75	70 x 39				3,68				19,84		
3,80	75 x 43					3,04	9,02		19,84		24,30
3,85	75 x 43										
3,90	75 x 43					3,11			19,84		24,30
3,95	75 x 43										
3,97	5/32"										
4,00	75 x 43	3,25	3,09	4,44	3,68	3,19	7,18	8,79	16,91	15,65	20,22
4,05	75 x 43										
4,10	75 x 43					3,27	7,73		20,75		24,67

Rosa
Punte Metallo

Ø 2,85-4,10mm

PUNTE ELICOIDALI CILINDRICI DIN 338

Punte Metallo

Grigio

Rosso

**DIN
338**

		BC2	BC82	BC02	BC9	BC5	BC99	BC58	BC16	BC66	BC15	BC18
MATERIALE		HSS	HSS	HSS-G	HSS	HSSCo 5%	HSSCo 5%	HSSCo 8%	HSS	HSS	HSS	HSS
TIPO DI AFFILATURA												
ANGOLO DI TAGLIO		118°	118°	118°	118°	135°	135°	135°	135°	118°	118°	118°
ELICA		30° "N"	30° "N"	30° "N"	30° "N"	30° "N"	30° "N"	30° "N"	40° "W"	15° "H"	30° "N"	30° "N"
FINITURA		OX	BRILLANTE	DORATO OX	OX	DORATO	DORATO	DORATO	BRILLANTE	BRILLANTE	OX	TiN
APPLICAZIONE												
Ø mm	L1 x L2	€	€	€	€	€	€	€	€	€	€	€
4,15	75 x 43	2,02										
4,20	75 x 43	1,82	1,82	2,02		3,46		5,81	3,35			2,80
4,25	75 x 43	1,82	1,82	2,03		3,46		5,27	3,73	5,20		2,80
4,30	80 x 47	2,40	2,40	2,72		3,65						2,97
4,35	80 x 47	2,36										
4,37	11/64"	2,26				3,47						
4,40	80 x 47	2,40	2,40	2,72		3,65						2,94
4,45	80 x 47	2,40										
4,50	80 x 47	1,88	1,88	2,05		3,56		5,27	3,29	4,28	3,47	2,81
4,55	80 x 47	2,43										
4,60	80 x 47	2,43	2,43			4,07						3,12
4,65	80 x 47	2,43										
4,70	80 x 47	2,45	2,45	2,72		4,07						3,12
4,75	80 x 47	2,06	2,06	2,45		3,86		5,82	4,18	5,84		3,01
4,76	3/16"	2,05				3,62						
4,80	86 x 52	2,72	2,72	2,97		4,08		6,42				3,31
4,85	86 x 52	2,64										
4,90	86 x 52	2,64	2,64	2,90		4,08						3,28
4,95	86 x 52	2,65										
5,00	86 x 52	1,98	1,98	2,25		3,72		5,65	3,51	4,66	3,94	2,86
5,05	86 x 52	2,73	2,73									
5,10	86 x 52	2,72	2,72	3,01		4,47		6,91	4,26		5,55	3,30
5,15	86 x 52	2,73										
5,16	13/64"	2,62				3,81						
5,20	86 x 52	2,72	2,72	3,01		4,47		6,91				3,29
5,25	86 x 52	2,55	2,55	2,88		4,38		6,64	5,01	6,97		3,27
5,30	86 x 52	3,38	3,38	3,74		4,45						3,71
5,35	93 x 57	3,37										
5,40	93 x 57	3,38	3,38			4,47						3,71

PUNTE ELICOIDALI CILINDRICI DIN 338



- 10 U.** Ø 0,20 - Ø 10,50 mm
- 6 U.** Ø 10,60 - Ø 14 mm
- 1 U.** Ø 14,10 - Ø 20 mm
- 1 U.** BC9-BC99
BC7-BC98-BC42

Punte Metallo
Rosa

		BTX	TTX	BC51	BC95	BC55	BC57	BC50	BC7	BC98	BC42
MATERIALE		HSSCo 5%	HSS	HSSCo 5%	HSSCo 5%	HSSCo 5%	HSSCo 5%	HSSCo 5%	PMD	PMD	MD
TIPO DI AFFILATURA											
ANGOLO DI TAGLIO		135°	135°	135°	130°	135°	135°	118°	118°	135°	135°
ELICA		38° "S"	38° "S"	30° "N"	Ø ≥ 3	38° "S"	38° "S"	38° "N"	30° "N"	30° "N"	35° "N"
FINITURA		DORATO	TiAlSiN	TiAlN	DORATO OX	BRILLANTE	TiAlN	TiAlN	BRILLANTE	BRILLANTE	BRILLANTE
APPLICAZIONE											
Ø mm	L1 x L2	€	€	€	€	€	€	€	€	€	€
4,15	75 x 43										
4,20	75 x 43	3,63	3,44	4,67	4,10	3,35	7,71	9,41	20,75	18,24	25,09
4,25	75 x 43			4,67					20,75		
4,30	80 x 47					3,49	8,24		20,75	18,24	33,05
4,35	80 x 47										
4,37	11/64"										
4,40	80 x 47					3,49			20,75	18,24	33,71
4,45	80 x 47										
4,50	80 x 47	3,63	3,44	4,75	4,10	3,56	7,89	9,05	17,29	15,05	27,76
4,55	80 x 47										
4,60	80 x 47					4,06			20,75		30,02
4,65	80 x 47										
4,70	80 x 47					4,06			20,75		30,02
4,75	80 x 47				4,22				20,75		
4,76	3/16"										
4,80	86 x 52					4,27	8,74		20,75		32,82
4,85	86 x 52										
4,90	86 x 52					4,27			20,75		32,82
4,95	86 x 52										
5,00	86 x 52	4,30	4,09	4,86	4,38	3,84	8,17	9,06	17,81	14,75	31,42
5,05	86 x 52										
5,10	86 x 52					4,18	9,17		21,79	18,05	36,86
5,15	86 x 52										
5,16	13/64"										
5,20	86 x 52					4,47	9,26		21,79		34,92
5,25	86 x 52				5,16				21,79		
5,30	86 x 52					4,43			21,79		34,92
5,35	93 x 57										
5,40	93 x 57					4,47			21,79		39,53

Ø 4,15-5,40mm

PUNTE ELICOIDALI CILINDRICI DIN 338

Punte Metallo

Grigio

Rosso

**DIN
338**

		BC2	BC82	BC02	BC9	BC5	BC99	BC58	BC16	BC66	BC15	BC18
MATERIALE		HSS	HSS	HSS-G	HSS	HSSCo 5%	HSSCo 5%	HSSCo 8%	HSS	HSS	HSS	HSS
TIPO DI AFFILATURA												
ANGOLO DI TAGLIO		118°	118°	118°	118°	135°	135°	135°	135°	118°	118°	118°
ELICA		30° "N"	30° "N"	30° "N"	30° "N"	30° "N"	30° "N"	30° "N"	40° "W"	15° "H"	30° "N"	30° "N"
FINITURA		OX	BRILLANTE	DORATO OX	OX	DORATO	DORATO	DORATO	BRILLANTE	BRILLANTE	OX	TiN
APPLICAZIONE												
Ø mm	L1 x L2	€	€	€	€	€	€	€	€	€	€	€
5,45	93 x 57	3,38										
5,50	93 x 57	2,65	2,65	2,97		4,71		7,12	4,48	5,62	5,07	3,31
5,55	93 x 57	3,59										
5,56	7/32"	3,41				5,31						
5,60	93 x 57	3,62	3,62	3,98		5,57		8,81				3,86
5,65	93 x 57	3,59										
5,70	93 x 57	3,62	3,62	3,98		5,57		8,81				3,86
5,75	93 x 57	3,46	3,46	3,87		5,30		7,97	6,14	7,60		3,83
5,80	93 x 57	3,37	3,37	3,82		5,57		8,81				3,71
5,85	93 x 57	3,38										
5,90	93 x 57	3,37	3,37	3,80		5,57						3,71
5,95	15/64"	3,19				5,80						
6,00	93 x 57	2,78	2,78	3,06		5,05		7,59	4,74	6,10	5,61	3,37
6,05	101 x 63	3,92										
6,10	101 x 63	3,92	3,92	4,44		6,25						6,11
6,15	101 x 63	3,92										
6,20	101 x 63	3,92	3,92	4,44		6,25						6,11
6,25	101 x 63	3,71	3,71	4,14		5,89		8,89	6,14	8,54		6,77
6,30	101 x 63	4,12	4,12			6,25						6,14
6,35	1/4"	2,96				5,95						
6,40	101 x 63	4,27	4,27			6,26						6,17
6,45	101 x 63	4,15										
6,50	101 x 63	3,20	3,20	3,64		6,05		8,87	5,53	6,80	7,01	5,77
6,55	101 x 63	5,20										
6,60	101 x 63	5,15	5,15			7,54						7,01
6,65	101 x 63	5,20										
6,70	101 x 63	5,19	5,19	5,76		7,54		11,35				7,01
6,75	109 x 69	3,90	3,90	4,39		7,07		10,37	7,40	9,17		6,89
6,80	109 x 69	3,90	3,90	4,39		7,07		11,35	6,50			6,90

PUNTE ELICOIDALI CILINDRICHE DIN 338



- 10 U. Ø 0,20 - Ø 10,50 mm
- 5 U. Ø 10,60 - Ø 14 mm
- 1 U. Ø 14,10 - Ø 20 mm
- 1 U. BC9-BC99
BC7-BC98-BC42

	BTX	TTX	BC51	BC95	BC55	BC57	BC50	BC7	BC98	BC42	
MATERIALE	HSSCo 5%	HSS	HSSCo 5%	HSSCo 5%	HSSCo 5%	HSSCo 5%	HSSCo 5%	PMD	PMD	MD	
TIPO DI AFFILATURA											
ANGOLO DI TAGLIO	135°	135°	135°	130°	135°	135°	118°	118°	135°	135°	
ELICA	38° "S"	38° "S"	30° "N"	Ø ≥ 3	38° "S"	38° "S"	38° "N"	30° "N"	30° "N"	35° "N"	
FINITURA	DORATO	TiAlSiN	TiAlN	DORATO OX	BRILLANTE	TiAlN	TiAlN	BRILLANTE	BRILLANTE	BRILLANTE	
APPLICAZIONE											
Ø mm	L1 x L2	€	€	€	€	€	€	€	€	€	
5,45	93 x 57										
5,50	93 x 57	5,45	5,17	5,50	5,55	5,57	9,67	10,10	19,01	15,72	35,93
5,55	93 x 57										
5,56	7/32"										
5,60	93 x 57					5,72		22,79		41,52	
5,65	93 x 57										
5,70	93 x 57					5,61		22,79		41,52	
5,75	93 x 57			5,73	5,67			22,79			
5,80	93 x 57				5,72	11,07		22,79		41,52	
5,85	93 x 57										
5,90	93 x 57				5,67			22,79		41,52	
5,95	15/64"										
6,00	93 x 57	5,80	5,50	5,63	5,90	5,85	10,18	10,78	20,25	16,74	39,56
6,05	101 x 63										
6,10	101 x 63				7,23	6,42		23,32		51,43	
6,15	101 x 63										
6,20	101 x 63					6,63	15,97	23,32		51,43	
6,25	101 x 63				6,89			23,32			
6,30	101 x 63					6,58		23,32		51,43	
6,35	1/4"										
6,40	101 x 63					6,58		23,32		51,43	
6,45	101 x 63										
6,50	101 x 63	6,77	6,43	10,51	6,89	6,58	15,70	12,70	20,64	17,07	49,37
6,55	101 x 63										
6,60	101 x 63					7,08		24,70		63,94	
6,65	101 x 63										
6,70	101 x 63					7,08		24,70		63,94	
6,75	109 x 69			11,12	7,78			24,70			
6,80	109 x 69	7,87	7,47	11,12	8,12	7,25	17,26	24,70	20,44	59,36	

Rosa
Punte Metallo

Ø 5,45-6,80mm

PUNTE ELICOIDALI CILINDRICI DIN 338

Punte Metallo

Grigio

Rosso

**DIN
338**

		BC2	BC82	BC02	BC9	BC5	BC99	BC58	BC16	BC66	BC15	BC18
MATERIALE		HSS	HSS	HSS-G	HSS	HSSCo 5%	HSSCo 5%	HSSCo 8%	HSS	HSS	HSS	HSS
TIPO DI AFFILATURA												
ANGOLO DI TAGLIO		118°	118°	118°	118°	135°	135°	135°	135°	118°	118°	118°
ELICA		30° "N"	30° "N"	30° "N"	30° "N"	30° "N"	30° "N"	30° "N"	40° "W"	15° "H"	30° "N"	30° "N"
FINITURA		OX	BRILLANTE	DORATO OX	OX	DORATO	DORATO	DORATO	BRILLANTE	BRILLANTE	OX	TiN
APPLICAZIONE												
Ø mm	L1 x L2	€	€	€	€	€	€	€	€	€	€	€
6,85	109 x 69	5,73										
6,90	109 x 69	5,74	5,74			7,54						7,07
6,95	109 x 69	5,74										
7,00	109 x 69	3,90	3,90	4,39		6,64		9,28	6,05	7,15	7,86	6,18
7,05	109 x 69	6,03										
7,10	109 x 69	6,02	6,02			9,58						8,10
7,14	9/32"	5,77				9,03						
7,15	109 x 69	6,04										
7,20	109 x 69	6,02	6,02			9,58					8,28	8,10
7,25	109 x 69	4,82	4,82	5,52		9,02		12,60	9,77	12,28		7,57
7,30	109 x 69	6,03	6,03			9,60						8,10
7,35	109 x 69	6,02										
7,40	109 x 69	6,03	6,03	6,77		9,60						8,10
7,45	109 x 69	6,21										
7,50	109 x 69	4,12	4,12	4,61		7,08		9,90	6,42	8,45	8,35	7,07
7,54	19/64"	6,74				10,95						
7,55	117 x 75	7,15										
7,60	117 x 75	7,11	7,11			11,55						8,38
7,65	117 x 75	7,15										
7,70	117 x 75	7,11	7,11			11,52						8,38
7,75	117 x 75	5,49	5,49	6,14		10,93		15,29	12,43	17,83		8,08
7,80	117 x 75	7,22	7,22	8,12		11,52						8,35
7,85	117 x 75	7,23										
7,90	117 x 75	7,22	7,22	8,12		11,58						8,35
7,94	5/16"	6,16				10,92						
7,95	117 x 75	7,22										
8,00	117 x 75	4,75	4,75	5,33		8,29		11,59	7,54	8,97	9,54	7,39
8,05	117 x 75	7,42										
8,10	117 x 75	7,42	7,42			11,07						9,75

PUNTE ELICOIDALI CILINDRICI DIN 338



	BTX	TTX	BC51	BC95	BC55	BC57	BC50	BC7	BC98	BC42	
MATERIALE	HSSCo 5%	HSS	HSSCo 5%	HSSCo 5%	HSSCo 5%	HSSCo 5%	HSSCo 5%	PMD	PMD	MD	
TIPO DI AFFILATURA											
ANGOLO DI TAGLIO	135°	135°	135°	130°	135°	135°	118°	118°	135°	135°	
ELICA	38° "S"	38° "S"	30° "N"	Ø ≥ 3	38° "S"	38° "S"	38° "N"	30° "N"	30° "N"	35° "N"	
FINITURA	DORATO	TiAlSiN	TiAlN	DORATO OX	BRILLANTE	TiAlN	TiAlN	BRILLANTE	BRILLANTE	BRILLANTE	
APPLICAZIONE											
Ø mm	L1 x L2	€	€	€	€	€	€	€	€	€	
6,85	109 x 69										
6,90	109 x 69					7,34		24,70	20,44	63,94	
6,95	109 x 69										
7,00	109 x 69	7,40	7,03	11,07	7,54	7,61	16,76	13,28	21,93	19,10	57,46
7,05	109 x 69										
7,10	109 x 69					7,97		26,62	22,01	73,12	
7,14	9/32"										
7,15	109 x 69										
7,20	109 x 69					8,03	20,03	26,62		73,12	
7,25	109 x 69				7,66			26,62			
7,30	109 x 69					8,35		26,62		73,12	
7,35	109 x 69										
7,40	109 x 69					8,48		26,62		73,12	
7,45	109 x 69										
7,50	109 x 69	7,85	7,45	11,37	8,00	8,46	17,48	14,75	23,07	20,06	62,97
7,54	19/64"										
7,55	117 x 75										
7,60	117 x 75					8,98		28,59		73,12	
7,65	117 x 75										
7,70	117 x 75					9,48		28,59		73,12	
7,75	117 x 75				9,23			28,59			
7,80	117 x 75					9,48	20,74	28,59		73,12	
7,85	117 x 75										
7,90	117 x 75					9,48		28,59		73,12	
7,94	5/16"										
7,95	117 x 75										
8,00	117 x 75	9,20	8,74	12,06	9,37	9,55	19,29	14,67	25,77	22,42	70,32
8,05	117 x 75										
8,10	117 x 75					9,57		30,53		85,08	

Punte Metallo
Rosa

Ø 6,85-8,10mm

PUNTE ELICOIDALI CILINDRICI DIN 338



- 10 U. Ø 0,20 - Ø 10,50 mm
- 6 U. Ø 10,60 - Ø 14 mm
- 1 U. Ø 14,10 - Ø 20 mm
- 1 U. BC9-BC99
BC7-BC98-BC42



	BTX	TTX	BC51	BC95	BC55	BC57	BC50	BC7	BC98	BC42	
MATERIALE	HSSCo 5%	HSS	HSSCo 5%	HSSCo 5%	HSSCo 5%	HSSCo 5%	HSSCo 5%	PMD	PMD	MD	
TIPO DI AFFILATURA											
ANGOLO DI TAGLIO	135°	135°	135°	130°	135°	135°	118°	118°	135°	135°	
ELICA	38° "S"	38° "S"	30° "N"	Ø ≥ 3	38° "S"	38° "S"	38° "N"	30° "N"	30° "N"	35° "N"	
FINITURA	DORATO	TiAlSiN	TiAlN	DORATO OX	BRILLANTE	TiAlN	TiAlN	BRILLANTE	BRILLANTE	BRILLANTE	
APPLICAZIONE											
Ø mm	L1 x L2	€	€	€	€	€	€	€	€	€	
8,15	117 x 75										
8,20	117 x 75					9,61	24,94			85,08	
8,25	117 x 75			9,58				30,53			
8,30	117 x 75				9,97			30,53		85,08	
8,33	21/64"										
8,35	117 x 75										
8,40	117 x 75				9,97			30,53		85,08	
8,45	117 x 75										
8,50	117 x 75	9,60	9,13	13,50	9,79	10,29	20,96	16,18	27,12	22,42	81,81
8,55	125 x 81										
8,60	125 x 81				11,44			32,78	27,13	109,56	
8,65	125 x 81										
8,70	125 x 81				11,49			32,78		109,56	
8,73	11/32"										
8,75	125 x 81			11,44				32,78			
8,80	125 x 81				11,85	27,49		32,78		109,56	
8,85	125 x 81										
8,90	125 x 81				11,83			32,78		109,56	
8,95	125 x 81										
9,00	125 x 81	12,24	11,62	14,95	12,46	12,24	24,67	17,90	29,41	24,32	88,92
9,05	125 x 81										
9,10	125 x 81				12,60	12,33		35,44		126,39	
9,13	23/64"										
9,15	125 x 81										
9,20	125 x 81				12,82	12,55	28,45		35,44	126,39	
9,25	125 x 81				12,91			35,44			
9,30	125 x 81				12,91	13,75		35,44		126,39	
9,35	125 x 81										
9,40	125 x 81					13,75		35,44		126,39	
9,45	125 x 81										

Rosa
Punte Metallo

Ø 8,15-9,45mm

PUNTE ELICOIDALI CILINDRICI DIN 338

Punte Metallo

Grigio

Rosso

**DIN
338**

		BC2	BC82	BC02	BC9	BC5	BC99	BC58	BC16	BC66	BC15	BC18
MATERIALE		HSS	HSS	HSS-G	HSS	HSSCo 5%	HSSCo 5%	HSSCo 8%	HSS	HSS	HSS	HSS
TIPO DI AFFILATURA												
ANGOLO DI TAGLIO		118°	118°	118°	118°	135°	135°	135°	135°	118°	118°	118°
ELICA		30° "N"	30° "N"	30° "N"	30° "N"	30° "N"	30° "N"	30° "N"	40° "W"	15° "H"	30° "N"	30° "N"
FINITURA		OX	BRILLANTE	DORATO OX	OX	DORATO	DORATO	DORATO	BRILLANTE	BRILLANTE	OX	TiN
APPLICAZIONE												
Ø mm	L1 x L2	€	€	€	€	€	€	€	€	€	€	€
9,50	125 x 81	6,80	6,80	7,57		11,34		15,93	10,33	12,81	13,38	9,49
9,52	3/8"	6,36				10,80						
9,55	133 x 87	11,69										
9,60	133 x 87	11,54	11,54			18,27						12,49
9,65	133 x 87	11,69										
9,70	133 x 87	11,54	11,54			18,27						12,54
9,75	133 x 87	8,42	8,42	9,54		17,19		24,25	16,38	21,94		10,66
9,80	133 x 87	11,31	11,31			18,27						12,32
9,85	133 x 87	11,42										
9,90	133 x 87	11,42	11,42	12,46		18,27						12,32
9,92	25/64"	10,89				17,23						
9,95	133 x 87	11,39										
10,00	133 x 87	7,29	7,29	8,15	12,27	12,55		17,60	11,43	13,33	14,71	9,86
10,10	133 x 87	9,79	9,79	10,96		21,00						
10,20	133 x 87	9,08	9,08	10,17		17,70		31,81				15,26
10,25	133 x 87	10,15	10,15	12,58	16,19	21,67		31,81	18,74	32,71		17,37
10,30	133 x 87	11,42	11,42	12,71		21,05						
10,32	13/32"	10,89				19,95						
10,40	133 x 87	11,42	11,42			21,00						
10,50	133 x 87	9,06	9,06	10,15	13,81	17,71	25,32	25,89	15,24	16,01	18,62	14,17
10,60	133 x 87	12,54	12,54			24,41						
10,70	142 x 94	12,54	12,54			24,41						
10,72	27/64"	11,15				23,93						
10,75	142 x 94	11,71	11,71	12,95	18,28	25,37		37,03	21,93	29,87		17,92
10,80	142 x 94	13,88	13,88			24,41						
10,90	142 x 94	13,88	13,88			24,47						
11,00	142 x 94	10,58	10,58	11,87	15,57	19,56	27,34	28,56	16,54	17,82	22,41	14,90
11,10	142 x 94	14,17	14,17			27,86						
11,11	7 / 16"	13,49				26,29						
11,20	142 x 94	14,17	14,17			27,86						

PUNTE ELICOIDALI CILINDRICI DIN 338



- 10 U.** Ø 0,20 - Ø 10,50 mm
- 6 U.** Ø 10,60 - Ø 14 mm
- 1 U.** Ø 14,10 - Ø 20 mm
- 1 U.** BC9-BC99
BC7-BC98-BC42



		BTX	TTX	BC51	BC95	BC55	BC57	BC50	BC7	BC98	BC42
MATERIALE		HSSCo 5%	HSS	HSSCo 5%	HSSCo 5%	HSSCo 5%	HSSCo 5%	HSSCo 5%	PMD	PMD	MD
TIPO DI AFFILATURA											
ANGOLO DI TAGLIO		135°	135°	135°	130°	135°	135°	118°	118°	135°	135°
ELICA		38° "5"	38° "5"	30° "N"	Ø ≥ 3	38° "5"	38° "5"	38° "N"	30° "N"	30° "N"	35° "N"
FINITURA		DORATO	TiAlSiN	TiAlN	DORATO OX	BRILLANTE	TiAlN	TiAlN	BRILLANTE	BRILLANTE	BRILLANTE
APPLICAZIONE				ALTA PRODUZIONE	INOX	INOX	INOX	INOX Plus	GHISA	70 HRC	ALTA PRODUZIONE
Ø mm	L1 x L2	€	€	€	€	€	€	€	€	€	€
9,50	125 x 81	12,65	12,02	15,17	12,91	13,38	25,32	18,94	32,07	26,54	104,16
9,52	3/8"										
9,55	133 x 87										
9,60	133 x 87					13,75			38,03		114,90
9,65	133 x 87										
9,70	133 x 87					14,57			38,03		114,90
9,75	133 x 87								38,03		
9,80	133 x 87					14,63	31,08		38,03		114,90
9,85	133 x 87										
9,90	133 x 87					14,42			38,03		114,90
9,92	25/64"										
9,95	133 x 87										
10,00	133 x 87	13,93	13,24	15,91	14,20	15,48	26,96	19,67	32,90	27,22	109,18
10,10	133 x 87								42,60		
10,20	133 x 87	18,80	17,85	27,43	19,17	16,17	38,15	26,05	42,60	35,24	130,67
10,25	133 x 87				19,18				42,60		
10,30	133 x 87								42,60	35,24	
10,32	13/32"										
10,40	133 x 87								42,60		
10,50	133 x 87	18,81	17,86	27,41	19,18	17,54	39,00	25,36	35,56	34,97	122,02
10,60	133 x 87								45,30		
10,70	142 x 94								45,30		
10,72	27/64"										
10,75	142 x 94				20,86				45,30		
10,80	142 x 94					18,04			45,30		
10,90	142 x 94								45,30		
11,00	142 x 94	20,76	19,72	28,56	21,17	19,41	41,45	28,06	40,31	35,11	149,10
11,10	142 x 94				21,89				48,51		
11,11	7 / 16"										
11,20	142 x 94				23,64	20,13			48,51		

Punte Metallo
Rosa

Ø 9,50-11,20mm

PUNTE ELICOIDALI CILINDRICI DIN 338

Punte Metallo

Grigio

Rosso

**DIN
338**

		BC2	BC82	BC02	BC9	BC5	BC99	BC58	BC16	BC66	BC15	BC18
MATERIALE		HSS	HSS	HSS-G	HSS	HSSCo 5%	HSSCo 5%	HSSCo 8%	HSS	HSS	HSS	HSS
TIPO DI AFFILATURA												
ANGOLO DI TAGLIO		118°	118°	118°	118°	135°	135°	135°	135°	118°	118°	118°
ELICA		30° "N"	30° "N"	30° "N"	30° "N"	30° "N"	30° "N"	30° "N"	40° "N"	15° "H"	30° "N"	30° "N"
FINITURA		OX	BRILLANTE	DORATO OX	OX	DORATO	DORATO	DORATO	BRILLANTE	BRILLANTE	OX	TiN
APPLICAZIONE												
Ø mm	L1 x L2	€	€	€	€	€	€	€	€	€	€	€
11,25	142 x 94	12,02	12,02	13,95	19,35	28,33		42,13	28,86	39,35		18,08
11,30	142 x 94	13,88	13,88			27,84						
11,40	142 x 94	13,88	13,88			27,86						
11,50	142 x 94	11,31	11,31	12,70	16,50	23,41	29,56	36,52	19,55	21,62	24,49	15,89
11,51	29/64"	10,76				22,20						
11,60	142 x 94	13,88	13,88			28,76						
11,70	142 x 94	13,88	13,88			28,76						
11,75	142 x 94	12,02	12,02	14,36	21,08	29,88		44,40	28,31	39,35		18,08
11,80	142 x 94	14,77	14,77			28,76						
11,90	151 x 101	14,77	14,77			28,76						
11,91	15/32"	14,49				27,26						
12,00	151 x 101	12,64	12,64	14,16	17,98	24,95	31,68	39,12	20,97	23,19	27,37	17,38
12,10	151 x 101	17,73	17,73			33,41						
12,20	151 x 101	17,73	17,73			33,41						
12,25	151 x 101	15,65	15,65	17,60	22,88	33,90		55,79	39,36	53,62		23,08
12,30	151 x 101	16,19	16,19			33,41						
12,40	151 x 101	16,19	16,19			33,41						
12,50	151 x 101	13,89	13,89	15,52	19,51	30,49	38,56	46,63	23,33	26,31	30,00	19,42
12,60	151 x 101	17,31	17,31			34,75						
12,70	1/2"	15,32				33,07						
12,75	151 x 101	15,39	15,39	17,58	23,58	36,09		52,42	43,45	59,55		22,90
12,80	151 x 101	19,31	19,31			34,75						
12,90	151 x 101	19,31	19,31			34,75						
13,00	151 x 101	14,34	14,34	15,99	20,04	31,20	40,26	49,77	23,67	28,29	30,58	20,75
13,10	151 x 101	19,77	19,77									
13,20	151 x 101	19,77	19,77									
13,25	160 x 108	22,55	22,55		28,66	43,18						
13,30	160 x 108	30,60	30,60									
13,40	160 x 108	30,60	30,60									
13,49	17/32"	19,36				32,74						

PUNTE ELICOIDALI CILINDRICHE DIN 338



- 10 U.** Ø 0,20 - Ø 10,50 mm
- 6 U.** Ø 10,60 - Ø 14 mm
- 1 U.** Ø 14,10 - Ø 20 mm
- 1 U.** BC9-BC99
BC7-BC98-BC42



	BTX	TTX	BC51	BC95	BC55	BC57	BC50	BC7	BC98	BC42
MATERIALE	HSSCo 5%	HSS	HSSCo 5%	HSSCo 5%	HSSCo 5%	HSSCo 5%	HSSCo 5%	PMD	PMD	MD
TIPO DI AFFILATURA										
ANGOLO DI TAGLIO	135°	135°	135°	130°	135°	135°	118°	118°	135°	135°
ELICA	38° "S"	38° "S"	30° "N"	Ø ≥ 3	38° "S"	38° "S"	38° "N"	30° "N"	30° "N"	35° "N"
FINITURA	DORATO	TiAlSiN	TiAlN	DORATO OX	BRILLANTE	TiAlN	TiAlN	BRILLANTE	BRILLANTE	BRILLANTE
APPLICAZIONE			ALTA PRODUZIONE	INOX	INOX	INOX	INOX Plus	GHISA	70 Hrc	ALTA PRODUZIONE
Ø mm	L1 x L2	€	€	€	€	€	€	€	€	€
11,25	142 x 94				23,80			48,51		
11,30	142 x 94				24,26			48,51		
11,40	142 x 94							48,51		
11,50	142 x 94	23,90	22,70	30,33	24,37	19,82	43,28	30,47	43,91	40,36
11,51	29/64"									167,25
11,60	142 x 94									
11,60	142 x 94							53,51	44,26	
11,70	142 x 94							53,51		
11,75	142 x 94				25,70			53,51		
11,80	142 x 94					21,86		53,51		
11,90	151 x 101							53,51		
11,91	15/32"									
12,00	151 x 101	25,63	24,34	31,38	26,12	23,19	48,60	30,83	46,11	40,16
12,10	151 x 101							56,32	46,60	202,81
12,20	151 x 101							56,32		
12,25	151 x 101							56,32		
12,30	151 x 101							56,32		
12,40	151 x 101							56,32		
12,50	151 x 101	31,27	29,71	38,79	29,11	26,97	51,94	34,90	52,39	241,92
12,60	151 x 101							59,50		
12,70	1/2"							59,50		
12,75	151 x 101							59,50		
12,80	151 x 101							59,50		
12,90	151 x 101							59,50		
13,00	151 x 101	31,73	30,14	39,38	29,54	27,72	51,46	36,47	58,09	224,01
13,10	151 x 101									
13,20	151 x 101									
13,25	160 x 108									
13,30	160 x 108									
13,40	160 x 108									
13,49	17/32"									

Punte Metallo
Rosa

Ø 11,25-13,49mm

PUNTE ELICOIDALI CILINDRICI DIN 338

Punte Metallo

Grigio

Rosso

**DIN
338**

		BC2	BC82	BC02	BC9	BC5	BC99	BC58	BC16	BC66	BC15	BC18
MATERIALE		HSS	HSS	HSS-G	HSS	HSSCo 5%	HSSCo 5%	HSSCo 8%	HSS	HSS	HSS	HSS
TIPO DI AFFILATURA												
ANGOLO DI TAGLIO		118°	118°	118°	118°	135°	135°	135°	135°	118°	118°	118°
ELICA		30° "N"	30° "N"	30° "N"	30° "N"	30° "N"	30° "N"	30° "N"	40° "W"	15° "H"	30° "N"	30° "N"
FINITURA		OX	BRILLANTE	DORATO OX	OX	DORATO	DORATO	DORATO	BRILLANTE	BRILLANTE	OX	TiN
APPLICAZIONE												
Ø mm	L1 x L2	€	€	€	€	€	€	€	€	€	€	€
13,50	160 x 108	20,33	20,33	22,81	26,74	34,37	45,95	54,87				27,13
13,60	160 x 108	30,60	30,60									
13,70	160 x 108	30,60	30,60									
13,75	160 x 108	22,81	22,81		30,74	43,18						
13,80	160 x 108	29,18	29,18									
13,89	35/64"	27,90				38,64						
13,90	160 x 108	29,30	29,30									
14,00	160 x 108	21,76	21,76	24,41	28,39	33,99	50,21	54,25				28,03
14,10	169 x 114	31,22										
14,20	169 x 114	31,22										
14,25	169 x 114	25,53	25,53		32,84	56,69						
14,29	9/16"	30,25				42,73						
14,30	169 x 114	31,77										
14,40	169 x 114	31,77										
14,50	169 x 114	23,51	23,51		30,70	48,19	64,19	76,91				29,06
14,60	169 x 114	32,34										
14,68	37/64"	24,32				53,99						
14,70	169 x 114	32,34										
14,75	169 x 114	25,53	25,53		37,70	56,69						
14,80	169 x 114	31,18										
14,90	169 x 114	31,18										
15,00	169 x 114	23,73	23,73	26,58	30,99	48,91	67,03	78,05				29,32
15,08	19/32"	22,61				46,59						
15,25	178 x 120	34,94			39,29	78,26						
15,48	39/64"	33,63				74,52						
15,50	178 x 120	27,80	27,80		35,79	56,57	74,80	90,26				30,92
15,75	178 x 120	35,31			40,72	75,89						
15,88	5/8"	27,51				55,93						
16,00	178 x 120	28,87	28,87		37,11	58,72	77,04	93,82				32,53
16,25	184 x 125	51,91			47,75							

PUNTE ELICOIDALI CILINDRICHE DIN 338



- 10 U. Ø 0,20 - Ø 10,50 mm
- 6 U. Ø 10,60 - Ø 14 mm
- 1 U. Ø 14,10 - Ø 20 mm
- 1 U. BC9-BC99
BC7-BC98-BC42



	BTX	TTX	BC51	BC95	BC55	BC57	BC50	BC7	BC98	BC42
MATERIALE	HSSCo 5%	HSS	HSSCo 5%	HSSCo 5%	HSSCo 5%	HSSCo 5%	HSSCo 5%	PMD	PMD	MD
TIPO DI AFFILATURA										
ANGOLO DI TAGLIO	135°	135°	135°	130°	135°	135°	118°	118°	135°	135°
ELICA	38° "S"	38° "S"	30° "N"	Ø ≥ 3	38° "S"	38° "S"	38° "N"	30° "N"	30° "N"	35° "N"
FINITURA	DORATO	TiAlSiN	TiAlN	DORATO OX	BRILLANTE	TiAlN	TiAlN	BRILLANTE	BRILLANTE	BRILLANTE
APPLICAZIONE	120 Kg/mm²	80 Kg/mm²	ALTA PRODUZIONE	INOX	INOX	INOX	INOX Plus	GHISA	70 HRc	ALTA PRODUZIONE
Ø mm	L1 x L2	€	€	€	€	€	€	€	€	€
13,50	160 x 108							64,06		
13,60	160 x 108									
13,70	160 x 108									
13,75	160 x 108									
13,80	160 x 108									
13,89	35/64"									
13,90	160 x 108									
14,00	160 x 108							67,61		
14,10	169 x 114									
14,20	169 x 114									
14,25	169 x 114									
14,29	9/16"									
14,30	169 x 114									
14,40	169 x 114									
14,50	169 x 114							72,76		
14,60	169 x 114									
14,68	37/64"									
14,70	169 x 114									
14,75	169 x 114									
14,80	169 x 114									
14,90	169 x 114									
15,00	169 x 114							77,43		
15,08	19/32"									
15,25	178 x 120									
15,48	39/64"									
15,50	178 x 120							90,59		
15,75	178 x 120									
15,88	5/8"									
16,00	178 x 120							89,30		
16,25	184 x 125									

Rosa
Punte Metallo

Ø 13,50-16,25mm

PUNTE ELICOIDALI CILINDRICI DIN 338

Punte Metallo

Grigio

Rosso

**DIN
338**

		BC2	BC82	BC02	BC9	BC5	BC99	BC58	BC16	BC66	BC15	BC18
MATERIALE		HSS	HSS	HSS-G	HSS	HSSCo 5%	HSSCo 5%	HSSCo 8%	HSS	HSS	HSS	HSS
TIPO DI AFFILATURA												
ANGOLO DI TAGLIO		118°	118°	118°	118°	135°	135°	135°	135°	118°	118°	118°
ELICA		30° "N"	30° "N"	30° "N"	30° "N"	30° "N"	30° "N"	30° "N"	40° "W"	15° "H"	30° "N"	30° "N"
FINITURA		OX	BRILLANTE	DORATO OX	OX	DORATO	DORATO	DORATO	BRILLANTE	BRILLANTE	OX	TiN
APPLICAZIONE												
Ø mm	L1 x L2	€	€	€	€	€	€	€	€	€	€	€
16,50	184 x 125	33,63	33,63		41,56	67,05	87,86					
16,75	184 x 125	54,37			46,85							
17,00	184 x 125	33,66	33,66		41,56	67,05	87,54					
17,25	191 x 130	56,42			52,78							
17,50	191 x 130	38,58	38,58		47,29	74,29	95,88					
17,75	191 x 130	62,48			55,64							
18,00	191 x 130	40,87	40,87		49,86	80,93	106,65					
18,25	198 x 135	61,30			67,92							
18,50	198 x 135	45,33	45,33		55,01	89,38	119,02					
18,75	198 x 135	62,99			62,83							
19,00	198 x 135	45,33	45,33		55,01	89,38	117,98					
19,25	205 x 140	82,32			67,07							
19,50	205 x 140	48,74	48,74		59,71	99,13	130,73					
19,75	205 x 140	80,12			75,11							
20,00	205 x 140	55,35	55,35		64,02	106,38	140,06					
20,50	205 x 140				79,85		166,74					
21,00	205 x 140				65,61		172,67					
21,50	209 x 140				78,84		190,76					
22,00	209 x 140				74,95		193,57					
22,50	214 x 140				80,16		207,04					
23,00	214 x 140				83,83		224,96					
23,50	220 x 145				88,18		249,72					
24,00	220 x 145				87,19		265,71					
24,50	225 x 150				93,94		286,27					
25,00	225 x 150				95,34		305,31					
26,00	243 x 157				127,07		345,58					
27,00	243 x 157				136,48		354,89					
28,00	253 x 167				141,20		390,97					
29,00	253 x 167				165,77		420,50					
30,00	258 x 171				174,25		435,22					

PUNTE ELICOIDALI CILINDRICI DIN 338



- 10 U.** Ø 0,20 - Ø 10,50 mm
- 6 U.** Ø 10,60 - Ø 14 mm
- 1 U.** Ø 14,10 - Ø 20 mm
- 1 U.** BC9-BC99
BC7-BC98-BC42



	BTX	TTX	BC51	BC95	BC55	BC57	BC50	BC7	BC98	BC42
MATERIALE	HSSCo 5%	HSS	HSSCo 5%	HSSCo 5%	HSSCo 5%	HSSCo 5%	HSSCo 5%	PMD	PMD	MD
TIPO DI AFFILATURA										
ANGOLO DI TAGLIO	135°	135°	135°	130°	135°	135°	118°	118°	135°	135°
ELICA	38° "S"	38° "S"	30° "N"	Ø ≥ 3	38° "S"	38° "S"	38° "N"	30° "N"	30° "N"	35° "N"
FINITURA	DORATO	TiAlSiN	TiAlN	DORATO OX	BRILLANTE	TiAlN	TiAlN	BRILLANTE	BRILLANTE	BRILLANTE
APPLICAZIONE										
Ø mm	L1 x L2	€	€	€	€	€	€	€	€	€
16,50	184 x 125							125,78		
16,75	184 x 125									
17,00	184 x 125							103,95		
17,25	191 x 130									
17,50	191 x 130							141,03		
17,75	191 x 130									
18,00	191 x 130							116,55		
18,25	198 x 135									
18,50	198 x 135							168,13		
18,75	198 x 135									
19,00	198 x 135							138,93		
19,25	205 x 140									
19,50	205 x 140							191,33		
19,75	205 x 140									
20,00	205 x 140							158,13		
20,50	205 x 140									
21,00	205 x 140									
21,50	209 x 140									
22,00	209 x 140									
22,50	214 x 140									
23,00	214 x 140									
23,50	220 x 145									
24,00	220 x 145									
24,50	225 x 150									
25,00	225 x 150									
26,00	243 x 157									
27,00	243 x 157									
28,00	253 x 167									
29,00	253 x 167									
30,00	258 x 171									

PUNTE MICROMETRICI IN METALLO DURO E REFRIGERAZIONE INTERNA DIN6537K/DIN6537L

Punte Metallo

NEW

Ref. BC84
Ref. BC97

MD

TOL D₁
m7TOL D₂
h6

TiAlN

HARDOX
450

3xD



5xD

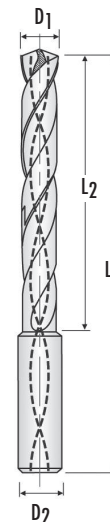

Punta speciale per HARDOX 450

BC84

DIN 6537K	D ₁ mm	D ₂ mm	L ₁ mm	L ₂ mm	€
BC840100	1,00	3	47	6,0	52,37
BC840110	1,10	3	47	6,6	52,37
BC840120	1,20	3	47	7,2	55,67
BC840130	1,30	3	47	7,8	55,67
BC840140	1,40	3	47	8,4	55,67
BC840150	1,50	3	47	9,0	55,67
BC840160	1,60	3	47	9,6	58,71
BC840170	1,70	3	47	10,2	58,71
BC840180	1,80	3	52	10,8	58,71
BC840190	1,90	3	52	11,4	58,71
BC840200	2,00	4	59	12,0	66,44
BC840210	2,10	4	59	12,6	66,44
BC840220	2,20	4	59	13,2	66,44
BC840230	2,30	4	59	13,8	66,44
BC840240	2,40	4	59	14,4	71,62
BC840250	2,50	4	59	15,0	71,62
BC840260	2,60	4	59	15,6	71,62
BC840270	2,70	4	59	16,2	71,62
BC840280	2,80	4	59	16,8	74,15
BC840290	2,90	4	59	17,4	74,15

BC97

DIN 6537L	D ₁ mm	D ₂ mm	L ₁ mm	L ₂ mm	€
BC970100	1,00	3	47	8,0	53,11
BC970110	1,10	3	47	8,8	55,67
BC970120	1,20	3	52	10,8	58,71
BC970130	1,30	3	52	11,7	60,76
BC970140	1,40	3	52	12,6	60,76
BC970150	1,50	3	52	13,5	60,76
BC970160	1,60	3	52	14,4	66,44
BC970170	1,70	3	52	15,3	66,44
BC970180	1,80	3	52	16,2	66,44
BC970190	1,90	3	52	17,1	66,44
BC970200	2,00	4	63	18,0	74,15
BC970210	2,10	4	63	18,9	74,15
BC970220	2,20	4	63	19,8	74,15
BC970230	2,30	4	63	20,7	75,46
BC970240	2,40	4	63	21,6	77,99
BC970250	2,50	4	63	22,5	77,99
BC970260	2,60	4	67	23,4	80,52
BC970270	2,70	4	67	24,3	80,52
BC970280	2,80	4	67	25,2	83,14
BC970290	2,90	4	67	26,1	83,14

PUNTE IN METALLO DURO E REFRIGERAZIONE INTERNA DIN6537K

Ref. BC84
Ref. BC83

3xD

DIN 6537K

MD

TOL D1 m7

TOL D2 h6







TiAIN

HARDOX 450



Punta speciale per HARDOX 450

BC84						BC83		BC84						BC83	
	D1 mm	D2 mm	L1 mm	L2 mm	€		€		D1 mm	D2 mm	L1 mm	L2 mm	€		€
BC840300	3,00	6	62	20	46,97	BC830300	80,68	BC840940	9,4	10	89	47	63,38	BC830940	110,68
BC840310	3,10	6	62	20	46,97	BC830310	80,68	BC840950	9,5	10	89	47	63,38	BC830950	110,68
BC840320	3,20	6	62	20	46,97	BC830320	80,68	BC840960	9,6	10	89	47	63,38	BC830960	110,68
BC840340	3,40	6	62	20	46,97	BC830300	80,68	BC840970	9,7	10	89	47	63,38	BC830970	110,68
BC840350	3,50	6	62	20	46,97	BC830350	80,68	BC840980	9,8	10	89	47	63,38	BC830980	110,68
BC840380	3,80	6	66	24	46,97	BC830380	80,68	BC840990	9,9	10	89	47	63,38	BC830990	110,68
BC840400	4,00	6	66	24	46,97	BC830400	80,68	BC841000	10,0	10	89	47	63,38	BC831000	110,68
BC840420	4,20	6	66	24	46,97	BC830420	80,68	BC841020	10,2	12	102	55	95,07	BC831020	158,17
BC840425	4,25	6	66	24	46,97	BC830425	80,68	BC841040	10,4	12	102	55	95,07	BC831040	158,17
BC840440	4,40	6	66	24	46,97	BC830440	80,68	BC841050	10,5	12	102	55	95,07	BC831050	158,17
BC840450	4,50	6	66	24	46,97	BC830450	80,68	BC841060	10,6	12	102	55	95,07	BC831060	158,17
BC840470	4,70	6	66	24	46,97	BC830470	80,68	BC841070	10,7	12	102	55	95,07	BC831070	158,17
BC840480	4,80	6	66	28	46,97	BC830480	80,68	BC841080	10,8	12	102	55	95,07	BC831080	158,17
BC840490	4,90	6	66	28	46,97	BC830490	80,68	BC841100	11,0	12	102	55	95,07	BC831100	158,17
BC840500	5,00	6	66	28	46,97	BC830500	80,68	BC841110	11,1	12	102	55	95,07	BC831110	158,17
BC840520	5,20	6	66	28	46,97	BC830520	80,68	BC841120	11,2	12	102	55	95,07	BC831120	158,17
BC840550	5,50	6	66	28	46,97	BC830550	80,68	BC841130	11,3	12	102	55	95,07	BC831130	158,17
BC840560	5,60	6	66	28	46,97	BC830560	80,68	BC841150	11,5	12	102	55	95,07	BC831150	158,17
BC840570	5,70	6	66	28	46,97	BC830570	80,68	BC841170	11,7	12	102	55	95,07	BC831170	158,17
BC840580	5,80	6	66	28	46,97	BC830580	80,68	BC841180	11,8	12	102	55	95,07	BC831180	158,17
BC840590	5,90	6	66	28	46,97	BC830590	80,68	BC841200	12,0	12	102	55	95,07	BC831200	158,17
BC840600	6,00	6	66	28	46,97	BC830600	80,68	BC841210	12,1	14	107	60	126,74	BC831210	220,07
BC840610	6,10	8	79	34	54,99	BC830610	98,81	BC841230	12,3	14	107	60	126,74	BC831230	220,07
BC840620	6,20	8	79	34	54,99	BC830620	98,81	BC841240	12,4	14	107	60	126,74	BC831240	220,07
BC840630	6,30	8	79	34	54,99	BC830630	98,81	BC841250	12,5	14	107	60	126,74	BC831250	220,07
BC840650	6,50	8	79	34	54,99	BC830650	98,81	BC841270	12,7	14	107	60	126,74	BC831270	220,07
BC840660	6,60	8	79	34	54,99	BC830660	98,81	BC841280	12,8	14	107	60	126,74	BC831280	220,07
BC840670	6,70	8	79	34	54,99	BC830670	98,81	BC841300	13,0	14	107	60	126,74	BC831300	220,07
BC840680	6,80	8	79	34	54,99	BC830680	98,81	BC841310	13,1	14	107	60	126,74	BC831310	220,07
BC840690	6,90	8	79	34	54,99	BC830690	98,81	BC841330	13,3	14	107	60	126,74	BC831330	220,07
BC840700	7,00	8	79	34	54,99	BC830700	98,81	BC841350	13,5	14	107	60	126,74	BC831350	220,07
BC840710	7,10	8	79	41	54,99	BC830710	98,81	BC841370	13,7	14	107	60	126,74	BC831370	220,07
BC840740	7,40	8	79	41	54,99	BC830740	98,81	BC841380	13,8	14	107	60	126,74	BC831380	220,07
BC840750	7,50	8	79	41	54,99	BC830750	98,81	BC841400	14,0	14	107	60	126,74	BC831400	220,07
BC840780	7,80	8	79	41	54,99	BC830780	98,81	BC841450	14,5	16	115	65	158,70	BC831450	272,35
BC840790	7,90	8	79	41	54,99	BC830790	98,81	BC841470	14,7	16	115	65	158,70	BC831470	272,35
BC840800	8,00	8	79	41	54,99	BC830800	98,81	BC841480	14,8	16	115	65	158,70	BC831480	272,35
BC840810	8,10	10	89	47	63,38	BC830810	110,68	BC841500	15,0	16	115	65	158,70	BC831500	272,35
BC840820	8,20	10	89	47	63,38	BC830820	110,68	BC841550	15,5	16	115	65	158,70	BC831550	272,35
BC840830	8,30	10	89	47	63,38	BC830830	110,68	BC841600	16,0	16	115	65	158,70	BC831600	272,35
BC840840	8,40	10	89	47	63,38	BC830840	110,68	BC841650	16,5	18	123	73	242,62	BC831650	429,44
BC840850	8,50	10	89	47	63,38	BC830850	110,68	BC841700	17,0	18	123	73	242,62	BC831700	429,44
BC840860	8,60	10	89	47	63,38	BC830860	110,68	BC841750	17,5	18	123	73	242,62	BC831750	429,44
BC840870	8,70	10	89	47	63,38	BC830870	110,68	BC841800	18,0	18	123	73	242,62	BC831800	429,44
BC840880	8,80	10	89	47	63,38	BC830880	110,68	BC841850	18,5	20	131	79	296,21	BC831850	471,92
BC840890	8,90	10	89	47	63,38	BC830890	110,68	BC841900	19,0	20	131	79	296,21	BC831900	471,92
BC840900	9,00	10	89	47	63,38	BC830900	110,68	BC841950	19,5	20	131	79	296,21	BC831950	471,92
BC840910	9,10	10	89	47	63,38	BC830910	110,68	BC842000	20,0	20	131	79	296,21	BC832000	471,92
BC840930	9,30	10	89	47	63,38	BC830930	110,68								



PUNTE IN METALLO DURO E REFRIGERAZIONE INTERNA DIN6537L

Punte Metallo

Rosso

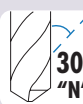
Ref. BC97
Ref. BC89
5xD
**DIN
6537L**
MD
**TOL D1
m7**
**TOL D2
h6**

TiAIN
**HARDOX
450**

Punta speciale per HARDOX 450

	BC97					BC89		BC97					BC89		
	D1 mm	D2 mm	L1 mm	L2 mm	€		€	D1 mm	D2 mm	L1 mm	L2 mm	€		€	
BC970300	3,0	6	66	28	57,28		95,76	BC970900	9,0	10	103	61	81,51		128,56
BC970310	3,1	6	66	28	57,28		95,76	BC970910	9,1	10	103	61	81,51		128,56
BC970320	3,2	6	66	28	57,28		95,76	BC970920	9,2	10	103	61	81,51		128,56
BC970340	3,4	6	66	28	57,28		95,76	BC970930	9,3	10	103	61	81,51		128,56
BC970350	3,5	6	66	28	57,28		95,76	BC970940	9,4	10	103	61	81,51		128,56
BC970360	3,6	6	66	28	57,28		95,76	BC970950	9,5	10	103	61	81,51		128,56
BC970380	3,8	6	74	36	57,28		95,76	BC970960	9,6	10	103	61	81,51		128,56
BC970390	3,9	6	74	36	57,28		95,76	BC970970	9,7	10	103	61	81,51		128,56
BC970400	4,0	6	74	36	57,28		98,72	BC970980	9,8	10	103	61	81,51		128,56
BC970420	4,2	6	74	36	57,28		98,72	BC970990	9,9	10	103	61	81,51		128,56
BC970440	4,4	6	74	36	57,28		98,72	BC971000	10,0	10	103	61	81,51		128,56
BC970450	4,5	6	74	36	57,28		98,72	BC971010	10,1	12	118	71	117,35		183,06
BC970460	4,6	6	74	36	57,28		98,72	BC971020	10,2	12	118	71	117,35		183,06
BC970470	4,7	6	74	36	57,28		98,72	BC971040	10,4	12	118	71	117,35		183,06
BC970480	4,8	6	82	44	57,28		98,72	BC971050	10,5	12	118	71	117,35		183,06
BC970490	4,9	6	82	44	57,28		98,72	BC971060	10,6	12	118	71	117,35		183,06
BC970500	5,0	6	82	44	57,28		98,72	BC971070	10,7	12	118	71	117,35		183,06
BC970520	5,2	6	82	44	57,28		98,72	BC971080	10,8	12	118	71	117,35		183,06
BC970530	5,3	6	82	44	57,28		98,72	BC971100	11,0	12	118	71	117,35		183,06
BC970540	5,4	6	82	44	57,28		98,72	BC971110	11,1	12	118	71	117,35		183,06
BC970550	5,5	6	82	44	57,28		98,72	BC971120	11,2	12	118	71	117,35		183,06
BC970560	5,6	6	82	44	57,28		98,72	BC971130	11,3	12	118	71	117,35		183,06
BC970570	5,7	6	82	44	57,28		98,72	BC971140	11,4	12	118	71	117,35		183,06
BC970580	5,8	6	82	44	57,28		98,72	BC971150	11,5	12	118	71	117,35		183,06
BC970590	5,9	6	82	44	57,28		98,72	BC971160	11,5	12	118	71	117,35		183,06
BC970600	6,0	6	82	44	57,28		98,72	BC971170	11,5	12	118	71	117,35		183,06
BC970610	6,1	8	91	53	62,72		110,61	BC971180	11,8	12	118	71	117,35		183,06
BC970620	6,2	8	91	53	62,72		110,61	BC971200	12,0	12	118	71	117,35		183,06
BC970630	6,3	8	91	53	62,72		110,61	BC971210	12,1	14	124	77	154,22		248,64
BC970640	6,4	8	91	53	62,72		110,61	BC971230	12,3	14	124	77	154,22		248,64
BC970650	6,5	8	91	53	62,72		110,61	BC971240	12,4	14	124	77	154,22		248,64
BC970660	6,6	8	91	53	62,72		110,61	BC971250	12,5	14	124	77	154,22		248,64
BC970670	6,7	8	91	53	62,72		110,61	BC971270	12,7	14	124	77	154,22		248,64
BC970680	6,8	8	91	53	62,72		110,61	BC971300	13,0	14	124	77	154,22		248,64
BC970690	6,9	8	91	53	62,72		110,61	BC971310	13,1	14	124	77	154,22		248,64
BC970700	7,0	8	91	53	62,72		110,61	BC971330	13,3	14	124	77	154,22		248,64
BC970710	7,1	8	91	53	62,72		110,61	BC971350	13,5	14	124	77	154,22		248,64
BC970720	7,2	8	91	53	62,72		110,61	BC971370	13,7	14	124	77	154,22		248,64
BC970730	7,3	8	91	53	62,72		110,61	BC971380	13,8	14	124	77	154,22		248,64
BC970740	7,4	8	91	53	62,72		110,61	BC971400	14,0	14	124	77	154,22		248,64
BC970750	7,5	8	91	53	62,72		110,61	BC971450	14,5	16	133	83	193,35		311,82
BC970760	7,6	8	91	53	62,72		110,61	BC971470	14,7	16	133	83	193,35		311,82
BC970770	7,7	8	91	53	62,72		110,61	BC971480	14,8	16	133	83	193,35		311,82
BC970780	7,8	8	91	53	62,72		110,61	BC971500	15,0	16	133	83	193,35		311,82
BC970790	7,9	8	91	53	62,72		110,61	BC971550	15,5	16	133	83	193,35		311,82
BC970800	8,0	8	91	53	62,72		110,61	BC971580	15,8	16	133	83	193,35		311,82
BC970810	8,1	10	103	61	81,51		128,56	BC971600	16,0	16	133	83	193,35		311,82
BC970830	8,3	10	103	61	81,51		128,56	BC971650	16,5	18	143	93	322,08		492,31
BC970840	8,4	10	103	61	81,51		128,56	BC971700	17,0	18	143	93	322,08		492,31
BC970850	8,5	10	103	61	81,51		128,56	BC971750	17,5	18	143	93	322,08		492,31
BC970860	8,6	10	103	61	81,51		128,56	BC971800	18,0	18	143	93	322,08		492,31
BC970870	8,7	10	103	61	81,51		128,56	BC971850	18,5	20	153	101	352,05		538,11
BC970880	8,8	10	103	61	81,51		128,56	BC971900	19,0	20	153	101	352,05		538,11
BC970890	8,9	10	103	61	81,51		128,56	BC971950	19,5	20	153	101	352,05		538,11
								BC972000	20,0	20	153	101	352,05		538,11

BC97

BC89

PUNTA IN METALLO DURO E REFRIGERAZIONE INTERNA DIN6537L

Ref. BC96

7xD

MD

**TOL D1
m7**

**TOL D2
h6**



TiAIN

**HARDOX
450**

**ALTA
PRODUZIONE**

Punta speciale per HARDOX 450

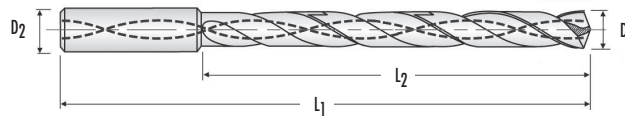

BC96					
	D1 mm	D2 mm	L1 mm	L2 mm	€
BC960300	3,00	6	72	34	177,85
BC960320	3,20	6	72	34	177,85
BC960350	3,50	6	72	34	177,85
BC960380	3,80	6	81	43	177,85
BC960400	4,00	6	81	43	177,85
BC960420	4,20	6	81	43	177,85
BC960450	4,50	6	81	43	177,85
BC960480	4,80	6	95	57	177,85
BC960500	5,00	6	95	57	177,85
BC960520	5,20	6	95	57	177,85
BC960550	5,50	6	95	57	177,85
BC960560	5,60	6	95	57	177,85
BC960570	5,70	6	95	57	177,85
BC960580	5,80	6	95	57	177,85
BC960590	5,90	6	95	57	177,85
BC960600	6,00	6	95	57	177,85
BC960610	6,10	8	114	76	193,74
BC960620	6,20	8	114	76	193,74
BC960630	6,30	8	114	76	193,74
BC960650	6,50	8	114	76	193,74
BC960660	6,60	8	114	76	193,74
BC960680	6,80	8	114	76	193,74
BC960690	6,90	8	114	76	193,74
BC960700	7,00	8	114	76	193,74
BC960710	7,10	8	114	76	193,74
BC960740	7,40	8	114	76	193,74
BC960750	7,50	8	114	76	193,74
BC960780	7,80	8	114	76	193,74
BC960800	8,00	8	114	76	193,74
BC960810	8,10	10	142	95	262,34
BC960840	8,40	10	142	95	262,34
BC960850	8,50	10	142	95	262,34
BC960860	8,60	10	142	95	262,34
BC960870	8,70	10	142	95	262,34
BC960880	8,80	10	142	95	262,34
BC960900	9,00	10	131	87	262,34
BC960930	9,30	10	142	95	262,34
BC960950	9,50	10	142	95	262,34
BC960960	9,60	10	142	95	262,34
BC960980	9,80	10	142	95	262,34
BC961000	10,00	10	142	95	262,34
BC961020	10,20	12	162	114	345,86
BC961040	10,40	12	162	114	345,86
BC961050	10,50	12	162	114	345,86
BC961060	10,60	12	162	114	345,86
BC961080	10,80	12	162	114	345,86
BC961100	11,00	12	162	114	345,86
BC961120	11,20	12	162	114	345,86
BC961150	11,50	12	162	114	345,86
BC961180	11,80	12	162	114	345,86
BC961200	12,00	12	162	114	345,86



PUNTA IN METALLO DURO E REFRIGERAZIONE INTERNA DIN6537L

Ref. BXX

12xD
**DIN
6537L**
MD
**TOL D1
m7**
**TOL D2
h6**

TiAIN
**HARDOX
450**
**ALTA
PRODUZIONE**

Punta speciale per HARDOX 450

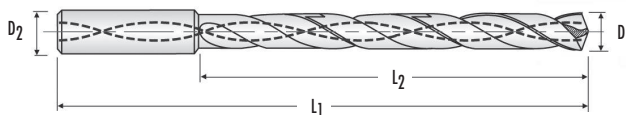

BXX					
	D1 mm	D2 mm	L1 mm	L2 mm	€
BXX0300	3,0	6	92	54	206,07
BXX0320	3,2	6	92	54	206,07
BXX0330	3,3	6	92	54	206,07
BXX0350	3,5	6	92	54	206,07
BXX0370	3,7	6	92	54	206,07
BXX0380	3,8	6	102	64	206,07
BXX0390	3,9	6	102	64	206,07
BXX0400	4,0	6	102	64	206,07
BXX0420	4,2	6	102	64	206,07
BXX0430	4,3	6	102	64	206,07
BXX0440	4,4	6	102	64	219,84
BXX0450	4,5	6	102	64	219,84
BXX0460	4,6	6	102	64	219,84
BXX0470	4,7	6	102	64	219,84
BXX0480	4,8	6	116	78	219,84
BXX0490	4,9	6	116	78	219,84
BXX0500	5,0	6	116	78	219,84
BXX0510	5,1	6	116	78	219,84
BXX0520	5,2	6	116	78	219,84
BXX0530	5,3	6	116	78	219,84
BXX0540	5,4	6	116	78	219,84
BXX0550	5,5	6	116	78	219,84
BXX0560	5,6	6	116	78	219,84
BXX0570	5,7	6	116	78	219,84
BXX0580	5,8	6	116	78	219,84
BXX0590	5,9	6	116	78	219,84
BXX0600	6,0	6	116	78	219,84
BXX0610	6,1	8	146	108	269,31
BXX0620	6,2	8	146	108	269,31
BXX0650	6,5	8	146	108	269,31
BXX0660	6,6	8	146	108	269,31
BXX0670	6,7	8	146	108	269,31
BXX0680	6,8	8	146	108	285,77
BXX0690	6,9	8	146	108	285,77
BXX0700	7,0	8	146	108	285,77

BXX					
	D1 mm	D2 mm	L1 mm	L2 mm	€
BXX0740	7,4	8	146	108	285,77
BXX0750	7,5	8	146	108	285,77
BXX0770	7,7	8	146	108	285,77
BXX0780	7,8	8	146	108	315,42
BXX0800	8,0	8	146	108	319,57
BXX0820	8,2	10	162	120	373,14
BXX0850	8,5	10	162	120	373,14
BXX0880	8,8	10	162	120	373,14
BXX0900	9,0	10	162	120	373,14
BXX0950	9,5	10	162	120	373,14
BXX0980	9,8	10	162	120	373,14
BXX0990	9,9	10	162	120	373,14
BXX1000	10,0	10	162	120	373,14
BXX1010	10,1	12	204	156	522,37
BXX1020	10,2	12	204	156	522,37
BXX1030	10,3	12	204	156	522,37
BXX1050	10,5	12	204	156	522,37
BXX1080	10,8	12	204	156	522,37
BXX1100	11,0	12	204	156	522,37
BXX1120	11,2	12	204	156	522,37
BXX1140	11,4	12	204	156	522,37
BXX1150	11,5	12	204	156	522,37
BXX1180	11,8	12	204	156	522,37
BXX1200	12,0	12	204	156	522,37
BXX1250	12,5	14	230	182	683,11
BXX1280	12,8	14	230	182	683,11
BXX1300	13,0	14	230	182	683,11
BXX1350	13,5	14	230	182	683,11
BXX1380	13,8	14	230	182	683,11
BXX1400	14,0	14	230	182	683,11
BXX1450	14,5	16	260	208	889,71
BXX1500	15,0	16	260	208	889,71
BXX1550	15,5	16	260	208	889,71
BXX1600	16,0	16	260	208	889,71



PUNTA IN METALLO DURO E REFRIGERAZIONE INTERNA DIN6537L

Ref. BXL
Ref. BXXL

**DIN
6537L**

MD

**TOL D1
m7**

**TOL D2
h6**



TiAIN

**HARDOX
450**



Punta speciale per HARDOX 450

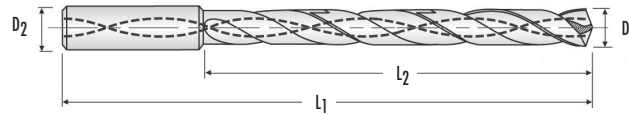

15xD

	D1 mm	D2 mm	L1 mm	L2 mm	BXL €
BXLO300	3,0	6	100	60	279,60
BXLO320	3,2	6	100	60	279,60
BXLO330	3,3	6	100	60	279,60
BXLO350	3,5	6	100	60	279,60
BXLO380	3,8	6	108	68	279,60
BXLO390	3,9	6	108	68	279,60
BXLO400	4,0	6	108	68	279,60
BXLO420	4,2	6	115	78	311,34
BXLO450	4,5	6	115	78	311,34
BXLO500	5,0	6	125	84	320,02
BXLO550	5,5	6	130	92	325,63
BXLO590	5,9	6	140	100	325,63
BXLO600	6,0	6	140	100	325,63
BXLO650	6,5	8	145	108	427,81
BXLO680	6,8	8	170	130	486,52
BXLO700	7,0	8	170	130	486,52
BXLO750	7,5	8	170	130	486,52
BXLO780	7,8	8	170	130	486,52
BXLO800	8,0	8	170	130	486,52
BXLO850	8,5	10	208	163	659,68
BXLO900	9,0	10	208	163	659,68
BXLO950	9,5	10	208	163	659,68
BXLO980	9,8	10	208	163	659,68
BXL1000	10,0	10	208	163	659,68
BXL1050	10,5	12	245	195	847,76
BXL1100	11,0	12	245	195	847,76
BXL1150	11,5	12	245	195	847,76
BXL1180	11,8	12	245	195	847,76
BXL1200	12,0	12	245	195	847,76
BXL1250	12,5	14	280	230	1.161,34
BXL1300	13,0	14	280	230	1.161,34
BXL1400	14,0	14	280	230	1.161,34
BXL1500	15,0	16	310	260	1.414,23

20xD

	D1 mm	D2 mm	L1 mm	L2 mm	BXXL €
BXXLO300	3,0	6	110	70	307,56
BXXLO350	3,5	6	136	96	307,56
BXXLO400	4,0	6	136	96	307,56
BXXLO450	4,5	6	158	118	342,47
BXXLO500	5,0	6	158	118	352,02
BXXLO510	5,1	6	180	140	358,19
BXXLO550	5,5	6	180	140	358,19
BXXLO600	6,0	6	180	140	358,19
BXXLO650	6,5	8	202	162	470,59
BXXLO700	7,0	8	202	162	535,17
BXXLO750	7,5	8	223	183	535,17
BXXLO800	8,0	8	223	183	535,17
BXXLO850	8,5	10	249	205	725,65
BXXLO900	9,0	10	249	205	725,65
BXXL1000	10,0	10	271	227	725,65



BXL

BXXL

PUNTE MICROMETRICHE CON CODOLO RINFORZATO

Ref. BC30

HSS

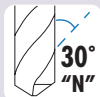

5xD

BC30				
	D ₁ mm	L ₁ mm	L ₂ mm	€
BC300050	0,50	43	5	3,36
BC300060	0,60	43	7	3,36
BC300070	0,70	43	7	3,36
BC300075	0,75	43	7	3,36
BC300080	0,80	43	7	3,36
BC300090	0,90	43	7	3,36
BC300095	0,95	43	7	3,36
BC300100	1,00	43	7	3,36
BC300110	1,10	43	7	3,36
BC300120	1,20	43	10	3,36
BC300125	1,25	43	10	3,36
BC300130	1,30	43	10	3,36

BC30				
	D ₁ mm	L ₁ mm	L ₂ mm	€
BC300140	1,40	43	10	3,36
BC300150	1,50	43	10	3,36
BC300160	1,60	43	10	3,36
BC300170	1,70	43	10	3,36
BC300175	1,75	43	10	3,36
BC300180	1,80	43	10	3,36
BC300190	1,90	43	10	3,36
BC300200	2,00	43	10	3,36
BC300210	2,10	43	10	3,36
BC300220	2,20	43	10	3,36
BC300225	2,25	43	10	3,36
BC300235	2,35	43	10	3,36
BC300240	2,40	43	10	3,36



Ref. BC79

MDI



ALTA PRODUZIONE

5xD

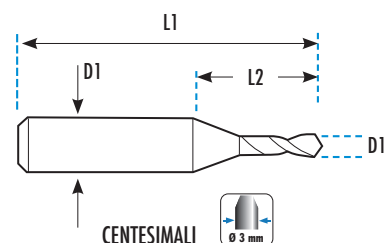

BC79				
	D ₁ mm	L ₁ mm	L ₂ mm	€
BC790025	0,25	38	5	28,84
BC790030	0,30	38	5	28,84
BC790035	0,35	38	5	28,84
BC790040	0,40	38	5	20,96
BC790045	0,45	38	5	20,96
BC790050	0,50	38	5	14,49
BC790055	0,55	38	5	14,49
BC790060	0,60	38	5	14,49
BC790065	0,65	38	5	13,07
BC790070	0,70	38	10	13,07
BC790075	0,75	38	10	13,07
BC790080	0,80	38	10	13,07
BC790085	0,85	38	10	13,07
BC790090	0,90	38	10	13,07
BC790095	0,95	38	10	13,07
BC790100	1,00	38	10	13,07
BC790105	1,05	38	10	13,07
BC790110	1,10	38	10	13,07
BC790115	1,15	38	10	13,07
BC790120	1,20	38	10	13,07
BC790125	1,25	38	10	13,07
BC790130	1,30	38	10	13,07
BC790135	1,35	38	10	13,07
BC790140	1,40	38	10	13,07
BC790145	1,45	38	10	13,07
BC790150	1,50	38	10	13,07
BC790155	1,55	38	10	13,07
BC790160	1,60	38	10	13,07
BC790165	1,65	38	10	16,43
BC790170	1,70	38	10	16,43

BC79				
	D ₁ mm	L ₁ mm	L ₂ mm	€
BC790175	1,75	38	10	16,43
BC790180	1,80	38	10	16,43
BC790185	1,85	38	10	16,43
BC790190	1,90	38	10	16,43
BC790195	1,95	38	10	16,43
BC790200	2,00	38	10	16,43
BC790205	2,05	38	10	16,43
BC790210	2,10	38	10	16,43
BC790215	2,15	38	10	16,43
BC790220	2,20	38	10	16,43
BC790225	2,25	38	10	16,43
BC790230	2,30	38	10	16,43
BC790235	2,35	38	10	16,43
BC790240	2,40	38	10	16,43
BC790245	2,45	38	10	16,43
BC790250	2,50	38	10	16,43
BC790255	2,55	38	10	16,43
BC790260	2,60	38	10	16,43
BC790265	2,65	38	10	16,43
BC790270	2,70	38	10	16,43
BC790275	2,75	38	10	16,43
BC790280	2,80	38	10	16,43
BC790285	2,85	38	10	16,43
BC790290	2,90	38	10	16,43
BC790295	2,95	38	10	16,43
BC790300	3,00	38	10	16,43
BC790305	3,05	38	10	16,43
BC790310	3,10	38	10	16,43
BC790315	3,15	38	10	16,43

BC79	
D ₁ mm	€
0,10 - 0,39	28,84
0,41 - 0,89	21,51
0,91 - 1,19	21,51
1,21 - 1,39	23,22
1,41 - 1,89	23,22
1,91 - 2,19	23,22
2,21 - 2,39	24,20
2,41 - 2,89	24,20
2,91 - 2,99	24,20

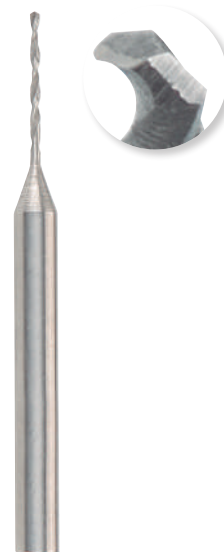

PUNTA IN METALLO DURO PER ACCIAI TEMPRATI E CORAZZATI AD ALTA RESISTENZA

Ref. BC85

**70
HRC**

MD

TOL D1
h7

TOL D2
h6



TiAIN

**HARDOX
600**



Punte Metallo

Rosa

Punta speciale per HARDOX 600

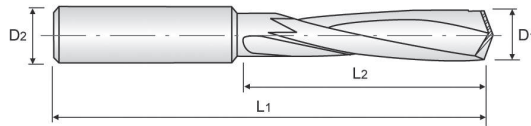

	BC85				
	D1 mm	D2 mm	L1 mm	L2 mm	€
BC850300	3,0	3	46	16	47,17
BC850330	3,3	4	48	18	54,14
BC850340	3,4	4	50	20	54,14
BC850350	3,5	4	50	20	54,14
BC850400	4,0	4	52	22	57,98
BC850420	4,2	6	65	25	78,42
BC850430	4,3	6	68	28	78,42
BC850440	4,4	6	68	28	78,42
BC850450	4,5	6	68	28	78,42
BC850500	5,0	6	72	32	78,42
BC850510	5,1	6	72	32	78,42
BC850520	5,2	6	72	32	78,42
BC850550	5,5	6	75	35	78,42
BC850600	6,0	6	75	35	78,42
BC850630	6,3	8	80	40	97,28*
BC850650	6,5	8	80	40	97,28
BC850680	6,8	8	85	45	97,28
BC850690	6,9	8	85	45	97,28
BC850700	7,0	8	85	45	97,28
BC850750	7,5	8	85	45	97,28
BC850800	8,0	8	98	50	97,28
BC850850	8,5	10	98	50	148,67
BC850860	8,6	10	105	57	148,67
BC850880	8,8	10	105	57	148,67
BC850900	9,0	10	105	57	148,67
BC850950	9,5	10	105	57	148,67
BC851000	10,0	10	111	63	148,67
BC851020	10,2	12	111	63	192,57
BC851030	10,3	12	111	63	225,94
BC851040	10,4	12	111	63	225,94
BC851050	10,5	12	111	63	225,94
BC851080	10,8	12	119	71	225,94
BC851100	11,0	12	119	71	225,94
BC851150	11,5	12	119	71	225,94
BC851200	12,0	12	119	71	225,94
BC851400	14,0	14	125	77	256,75

*Fino ad esaurimento scorte.

PERFORAZIONE DI VITI E MASCHI ROTTI

Vite rotta

STEP 1
Pulire la superficie

STEP 2
Forare con la punta BC85

STEP 3
Rimuovere i frammenti

STEP 4 (Opzionale)
Riparare la filettatura con inserti

PUNTA STEP CUT FACILE FORATURA SU SUPERFICI CURVATE E INSTABILI
**DIN
338**
HSS

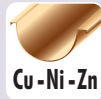
Al

Ref. TK02

Punta-Metallo

Rosa

STEP CUT

Punta elicoidale HSS con geometria STEP CUT, taglio a gradino.

NUOVA Punta STEP CUT con innovativa geometria a gradini che facilita una delicata penetrazione.

Lavora comodamente, velocemente e con precisione su superfici curve, instabili o inclinate.

Maggiore precisione, grazie alla punta di centraggio che impedisce lo scivolamento all'inizio della foratura.

La geometria STEP CUT con taglio a gradini genera fori più centrati, rotondi e precisi.

Il triplo piatto di ancoraggio ANTISLIP sul codolo trasmette adeguatamente la potenza del trapano.

Permette di realizzare fori passanti in acciaio, alluminio, rame, nichel, zinco, PVC, fibra di vetro e legno.

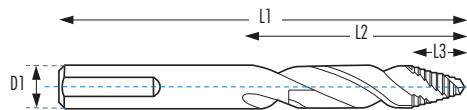

	TK02					
	D1 mm	L1 mm	L2 mm	L3 mm		€
TK020100	1,0	34	12	-	10	3,42
TK020150	1,5	40	18	-	10	3,52
TK020200	2,0	49	24	-	10	3,67
TK020250	2,5	57	30	1,6	10	4,27
TK020300	3,0	61	33	1,9	10	4,48
TK020320	3,2	65	36	2,1	10	5,00
TK020330	3,3	65	36	2,2	10	5,25
TK020350	3,5	70	39	2,1	10	5,36
TK020400	4,0	75	43	2,9	10	6,34
TK020410	4,1	75	43	3,0	10	6,63
TK020420	4,2	75	43	3,0	10	6,86
TK020450	4,5	80	47	3,3	10	6,97
TK020490	4,9	76	52	3,8	10	7,47
TK020500	5,0	76	52	3,9	10	7,87
TK020510	5,1	76	52	4,0	10	8,09
TK020520	5,2	76	52	4,2	10	8,26
TK020550	5,5	93	57	4,6	10	8,33
TK020600	6,0	93	57	5,3	10	9,08
TK020650	6,5	101	63	5,8	10	10,59
TK020680	6,8	109	69	5,9	10	11,90
TK020700	7,0	109	69	6,4	10	12,11
TK020750	7,5	109	69	6,9	10	14,16
TK020800	8,0	117	75	7,6	10	14,63
TK020850	8,5	117	75	8,2	10	17,36
TK020900	9,0	125	81	8,8	10	19,17
TK020950	9,5	125	81	9,3	10	20,68
TK021000	10,0	133	87	10,0	10	22,05
TK021020	10,2	133	87	9,9	10	23,12
TK021050	10,5	133	87	10,7	10	24,02
TK021100	11,0	142	94	11,3	6	26,52
TK021150	11,5	142	94	12,0	6	28,85
TK021200	12,0	151	101	12,6	6	31,48
TK021250	12,5	151	101	13,8	6	33,50
TK021300	13,0	151	101	14,7	6	36,11



PUNTA STEP CUT FACILE FORATURA SU SUPERFICI CURVATE E INSTABILI

Ref. TK05

DIN 338

HSSCo 5%



INOX



GHISA



PVC



Punte Metallo

Rosa



STEP CUT

Punta elicoidale HSSCo 5% ad Alte Prestazioni 5% STEP CUT, taglio a gradini.
 NUOVA Punta STEP CUT con innovativa geometria a gradini che facilita una delicata penetrazione.
 Lavora comodamente, velocemente e con precisione su superfici curve, instabili o inclinate.
 Maggiore precisione, grazie alla punta di centraggio che impedisce lo scivolamento all'inizio della foratura.
 La geometria STEP CUT con taglio a gradini genera fori più centrati, rotondi e precisi.
 Il triplo piatto di ancoraggio ANTISLIP sul codolo trasmette adeguatamente la potenza del trapano.
 Permette di realizzare fori passanti in acciaio inossidabile, ghisa, rame, nichel, zinco, PVC e fibra di vetro.

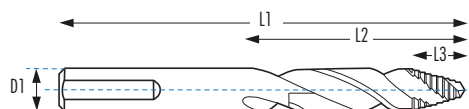

	D1 mm	L1 mm	L2 mm	L3 mm		TK05 €
TK050100	1,0	34	12	-	10	4,61
TK050150	1,5	40	18	-	10	4,76
TK050200	2,0	49	24	-	10	4,95
TK050250	2,5	57	30	1,6	10	5,77
TK050300	3,0	61	33	1,9	10	6,06
TK050350	3,5	70	39	2,1	10	7,23
TK050400	4,0	75	43	2,9	10	8,57
TK050450	4,5	80	47	3,3	10	9,41
TK050500	5,0	76	52	3,9	10	10,62
TK050550	5,5	93	57	4,6	10	11,25
TK050600	6,0	93	57	5,3	10	11,35
TK050650	6,5	101	63	5,8	10	13,24
TK050700	7,0	109	69	6,4	10	15,14
TK050750	7,5	109	69	6,9	10	17,71
TK050800	8,0	117	75	7,6	10	18,28
TK050850	8,5	117	75	8,2	10	21,70
TK050900	9,0	125	81	8,8	10	23,96
TK050950	9,5	125	81	9,3	10	25,85
TK051000	10,0	133	87	10,0	10	25,36
TK051050	10,5	133	87	10,7	10	27,61
TK051100	11,0	142	94	11,3	6	30,51
TK051150	11,5	142	94	12,0	6	33,18
TK051200	12,0	151	101	12,6	6	36,19
TK051250	12,5	151	101	13,8	6	38,51
TK051300	13,0	151	101	14,7	6	41,53



STRUMENTI STEP CUT FACILE FORATURA SU SUPERFICI CURVATE E INSTABILI

Punte Metallo

NEW
HSS
PUNTA MICROSCALINATA HSS STEPCUT
NEW
STEP CUT

SCALINO 2 mm

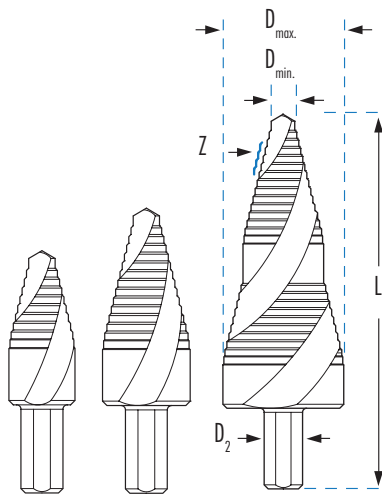

AV40BM37



AV40BM38



AV40BM36

	D min. mm	D max. mm	D2 mm	L1 mm	Z	Ø Z mm minore-maggiore	AV40BM
							HSS
AV40BM37B	6,0	15,0	9,5	55	11	6-7-8-9-10-11-12-13-14-14,5-15	€ 27,75
AV40BM38B	6,0	20,0	9,5	65	16	6-7-8-9-10-11-12-13-14-15-16-17-18-19-19,5-20	€ 41,49
AV40BM36B	6,0	30,0	9,5	93	27	6-7-8-9-10-11-12-13-14-15-16-17-18-19-19,5-20-21-22-23-24-25-26-27-28-29-29,5-30	€ 102,31

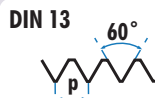
PUNTA MASCHIO SVASATRICE HSS STEPCUT
NEW

DIN 13

HSSCo
5%

BRILLANTE

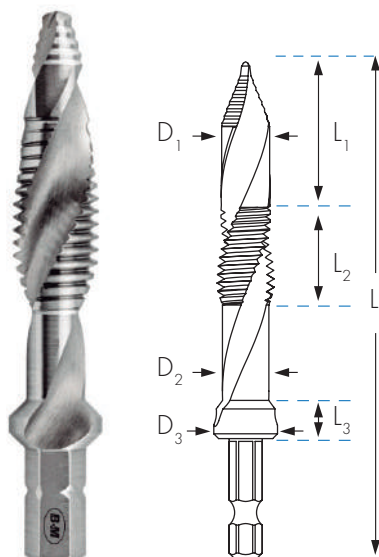
TOL
6H
D
CODOLO
SOTTILE
STEP CUT

			L1 mm	L2 mm	L3 mm	L mm	D1 mm	D2 mm	D3 mm	MTKM
										€
M	3x0,50	D	7,5	6,0	6,0	52,0	2,5	2,2	7,3	21,29
M	4x0,70	D	10,0	8,4	6,0	56,4	3,3	3,0	7,3	21,29
M	5x0,80	D	13,0	9,5	6,0	63,5	4,2	3,7	7,3	21,29
M	6x1,00	D	15,0	12,0	6,0	68,0	5,0	4,5	7,3	21,29
M	8x1,25	D	20,0	15,0	6,0	81,0	6,8	6,3	9,4	29,44
M	10x1,50	D	25,0	18,0	6,0	89,0	8,5	8,0	11,4	35,50
M	12x1,75	D	30,0	21,0	8,0	104,0	10,3	9,8	13,4	56,36

PUNTA QUADRATA PER PERFORARE CILINDRI

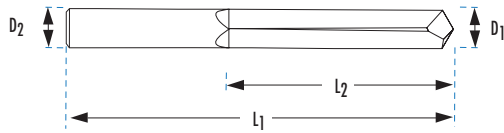
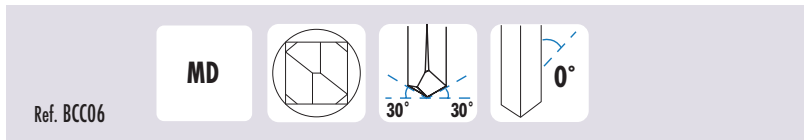

* Adatta per forare i cilindri "Anti-drilling"

BCC06					€
	D1 mm	D2 mm	L2 mm	L1 mm	
BCC06X60MD	6	6	33	60	76,11

* Per forare cilindri "Anti-drilling" lavorare a 300RPM

PUNTA ANTISCINTILLA PER LAVORI IN ATMOSFERE ESPLOSIVE (ATEX)

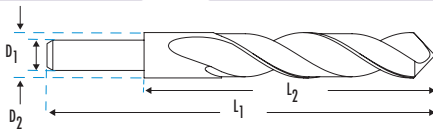
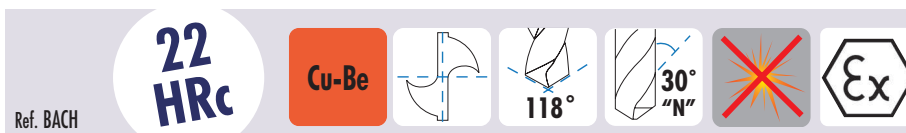

- * Fabricata in Rame-Berillio, in conformità allo standard Q/ZBF-312.
- * Certificati e schede di sicurezza disponibili.
- * Adatta per lavorare in atmosfere esplosive.

BACH					€
	D1 mm	D2 mm	L1 mm	L2 mm	
BACH0600	6,0	6,0	100	60	473,33
BACH0700	7,0	7,0	120	80	492,99
BACH0800	8,0	8,0	140	80	523,34
BACH0900	9,0	9,0	160	86	545,67
BACH1000	10,0	10,0	180	108	576,05
BACH1100	11,0	11,0	200	125	595,69
BACH1200	12,0	12,0	220	135	615,34
BACH1300	13,0	12,0	240	150	638,56
BACH1400	14,0	12,0	260	160	658,21
BACH1500	15,0	12,0	280	190	677,84
BACH1600	16,0	12,0	300	195	721,61
BACH1700	17,0	12,0	300	195	756,45
BACH1800	18,0	12,0	320	195	823,42
BACH1900	19,0	12,0	320	205	855,58
BACH2000	20,0	12,0	330	205	903,79

* Lunghezze speciali disponibili su richiesta



A causa delle loro caratteristiche speciali di durezza e resistenza (notevolmente inferiori a quelle che si possono ottenere negli utensili in acciaio), gli utensili antiscintilla non sono coperti da garanzia in caso di deformazione o rottura. La garanzia copre solamente le punte antiscintilla la cui durezza sia inferiore a 35 HRC.

PUNTA DELTABIT 3 TAGLIENTI
3Z

Ref. BTT33

**DIN
338**
**HSSCo
5%**

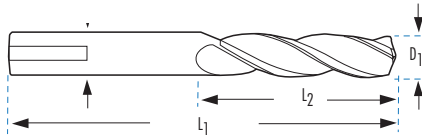
**TOL
H8**

- Maggiore precisione del foro
- Fori più arrotondati e più allineati
- Impugnatura tripla piatta antiscivolo, maggiore presa sul mandrino

BTT33

	D ₁ mm	L ₁ mm	L ₂ mm	€
BTT330300	3,0	61	33	2,75
BTT330330	3,3	65	36	3,55
BTT330350	3,5	70	39	3,55
BTT330400	4,0	75	43	4,17
BTT330420	4,2	75	43	5,14
BTT330450	4,5	80	47	5,14
BTT330500	5,0	86	52	5,87
BTT330550	5,5	93	57	7,29
BTT330600	6,0	93	57	8,42
BTT330650	6,5	101	63	9,68
BTT330680	6,8	109	69	11,13
BTT330700	7,0	109	69	11,13
BTT330750	7,5	109	69	12,71
BTT330800	8,0	117	75	15,21
BTT330850	8,5	117	75	16,91
BTT330900	9,0	125	81	19,61
BTT330950	9,5	125	81	21,35
BTT331000	10,0	133	87	24,06
BTT331020	10,2	133	87	26,80
BTT331050	10,5	133	87	26,80
BTT331100	11,0	142	94	30,86
BTT331150	11,5	142	94	33,36
BTT331200	12,0	151	101	38,59
BTT331250	12,5	151	101	41,30
BTT331300	13,0	151	101	44,01



PUNTA SPECIALE PER FORATURA DE HARDOX E LAMIERA ANTIUSURA

Ref. BHA

3xD

DIN 338

HSSCo 8%



135°

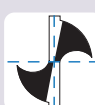

HARDTOP

HARDOX 400

HARDOX 450

HARDOX 600

Speciale geometria della punta, con Split Point e doppia sfaccettatura sottosquadro.
Il rivestimento **HARDTOP** migliora lo scorrimento del truciolo e previene l'adesione sul tagliente.
Migliora la resistenza meccanica e protegge la punta riducendo il coefficiente di attrito.
Il suo canale poco profondo genera un nucleo rinforzato che facilita la stabilità della lavorazione.
Massime prestazioni in materiali ad alta resistenza.

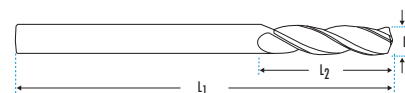

	BHA			
	D ₁ mm	L ₁ mm	L ₂ mm	€
BHA0100	1,0	34	6	12,02
BHA0150	1,5	40	9	12,02
BHA0200	2,0	49	12	12,49
BHA0250	2,5	57	14	12,73
BHA0300	3,0	61	16	12,84
BHA0320	3,2	65	18	13,67
BHA0330	3,3	65	18	13,67
BHA0350	3,5	70	20	13,67
BHA0400	4,0	75	22	14,52
BHA0420	4,2	75	22	18,93
BHA0450	4,5	80	24	18,93
BHA0500	5,0	86	26	17,94
BHA0550	5,5	93	28	24,24
BHA0600	6,0	93	28	22,71
BHA0650	6,5	101	31	26,18
BHA0680	6,8	109	34	30,41
BHA0700	7,0	109	34	28,03
BHA0750	7,5	109	34	33,57
BHA0800	8,0	117	37	36,50
BHA0850	8,5	117	37	36,50
BHA0900	9,0	125	40	43,70
BHA0950	9,5	125	40	49,33
BHA1000	10,0	133	43	47,85
BHA1020	10,2	133	43	55,67
BHA1050	10,5	133	43	60,13
BHA1100	11,0	142	47	62,57
BHA1150	11,5	142	47	70,45
BHA1200	12,0	151	51	65,62
BHA1250	12,5	151	51	86,20
BHA1300	13,0	151	51	93,94



Angolo di punta di 135°.
Fornisce un'eccellente centratura.

SMUSSO GUIDA STRETTO.
Fornisce un'eccellente centratura.

HARDTOP

Aumenta lo scorrimento del truciolo sul tagliente, evitandone l'aderenza e facilitando un rapido scorrimento lungo il canale di evacuazione.

HSSCo 8%

ACCIAIO M42 HSSCo 8%
Consente la lavorazione di materiali di elevata resistenza e durezza alle alte temperature.

Norma dimensionale DIN 338.

	BHA			
vc (m/min)	Hardox® HiTuf	Hardox® 400	Hardox® 450	Hardox® 600
Ø	f(mm/rev.)	f(mm/rev.)	f(mm/rev.)	f(mm/rev.)
2,5	0,035/1400	0,025/1000	0,015/770	0,005/500
3	0,04/1200	0,03/850	0,02/640	0,01/430
4	0,05/900	0,04/650	0,03/480	0,02/320
5	0,06/700	0,05/510	0,04/400	0,03/255
6	0,07/590	0,06/430	0,05/320	0,04/220
7	0,08/500	0,07/370	0,06/280	0,05/190
8	0,09/440	0,08/320	0,07/240	0,06/160
10	0,11/350	0,10/260	0,09/200	0,08/130
13	0,14/270	0,13/200	0,12/150	0,1/100

DIN 340								DIN 1897											
		BC4	BC47	BC40	BC44	BC48	BC78			BC3	BC31	BC37	BC33	BC35	BC77	BC43	BC17	BC38	
MATERIALE		HSS	HSSCo 5%	HSS	HSSCo 5%	HSSCo 5%	PMD			HSS	HSSCo 5%	HSS	HSSCo 5%	HSSCo 5%	PMD	MD	HSS	HSSCo 5%	
TIPO DI AFFILATURA																			
ANGOLO DI TAGLIO		118°	135°	118°	135°	135°	118°			135°	135°	135°	135°	118°	118°	135°	135°	135°	
ELICA		30° "N"	30° "N"	30° "N"	38° "S"	38° "S"	30° "N"			30° "N"	30° "N"	30° "N"	38° "S"	38° "N"	30° "N"	35° "N"	30° "N"	30° "N"	
FINITURA		OX	DORATO	TiN	BRILLANTE	TiAlN	BRILLANTE			OX	DORATO	TiN	BRILLANTE	TiAlN	BRILLANTE	BRILLANTE	OX	DORATO	
APPLICAZIONE																			
Ø mm	L1 x L2	€	€	€	€	€	€	L1 x L2	€	€	€	€	€	€	€	€	€	€	
2,75	100x66	3,87						46x16	1,09	2,26	2,35								
2,80	100x66	3,48			6,30			46x16	1,29	2,19	2,53					12,92			
2,90	100x66	3,75			6,29			46x16	1,29	2,19	2,53					12,92			
3,00	100x66	2,62	4,73	3,88	5,49	10,37	30,64	46x16	1,09	1,85	2,35	1,85	4,87	19,04	12,07	1,93			
3,10	106x69	2,94	5,41	4,53	5,70	12,17		49x18	1,17	1,96	2,67	2,06			13,10	1,94			
3,20	106x69	2,94	5,41		5,52	12,09		49x18	1,17	1,96	2,67	2,06			13,10	1,94			
3,25	106x69	2,94	5,41	4,53				49x18	1,17	1,96	2,67			22,24		1,94	3,01		
3,30	106x69	2,94			5,38	12,06		49x18	1,19	1,96	2,68	2,06	6,02		13,10	1,93			
3,40	112x73	3,76			7,21			52x20	1,35	2,42	2,83	2,01		23,35	14,11	2,17			
3,50	112x73	2,77	5,56	4,35	6,59	12,07	29,34	52x20	1,17	1,96	2,67	2,18	5,98	19,04	13,16	2,15	3,63		
3,60	112x73	3,76			7,88			52x20	1,48	2,42	2,98	2,51			15,50				
3,70	112x73	3,76			7,67			52x20	1,48	2,42	2,98	2,51	6,70		15,50				
3,75	112x73	3,90	6,39	5,50				52x20	1,32	2,50	2,81						2,45		
3,80	119x78	4,25			8,52			55x22	1,48	2,42	2,98	2,52			16,69	2,33			
3,90	119x78	4,25	6,39		8,30			55x22	1,48	2,42	2,98	2,52			16,69				
4,00	119x78	3,00	6,28	4,62	6,51	12,38	30,40	55x22	1,32	2,21	2,81	2,41	6,24	17,60	15,59	2,20	3,72		
4,10	119x78	3,91	6,90		6,89	13,87		55x22	1,58	2,64	3,04	2,64			17,52	2,22			
4,20	119x78	3,91	6,93		6,68	13,82		55x22	1,58	2,64	3,04	2,66	6,83	19,04	17,52	2,22			
4,25	119x78	3,91	6,93	5,50				55x22	1,58	2,64	3,04					2,37			
4,30	126x82	5,07		5,78	7,46	14,99		58x24	1,78	3,02	3,29	2,82			18,58				
4,40	126x82	5,07			9,70			58x24	1,78	3,02	3,29	2,93			18,58				
4,50	126x82	3,59	7,60	5,20	7,62	14,63	31,08	58x24	1,58	2,64	3,04	2,70	6,94	18,60	18,05	2,45			
4,60	126x82	4,77			9,98			58x24	2,02	3,15	3,51	3,25			18,58				
4,70	126x82	4,77			9,42			58x24	2,02	3,15	3,51	3,13			19,91				
4,75	126x82	5,26	7,79	6,87				58x24	1,73	2,94	3,21						3,96		
4,80	132x87	5,29	7,79		10,43			62x26	2,02	3,15	3,51	3,18			19,91				
4,90	132x87	5,29			10,76			62x26	2,02	3,15	3,51	3,59			19,91				
5,00	132x87	3,75	7,76	5,41	8,27	15,08	31,35	62x26	1,66	2,93	3,21	3,46	7,31	18,60	18,56	2,50	4,75		
5,10	132x87	5,84	9,13		8,68	17,12		62x26	2,22	3,61	3,71	3,92		20,92	19,91	3,57			
5,20	132x87	5,84			8,71		35,72	62x26	2,20	3,57	3,69	4,10			25,78	3,57			
5,25	132x87	6,12	9,13	7,65				62x26	1,92	3,27	3,41					3,20			
5,30	132x87	5,96			11,30	17,73		62x26	2,22	3,57	3,72	3,97			25,78				
5,40	139x91	6,36			12,71			66x28	2,22	3,57	3,72	4,32			25,78				
5,50	139x91	5,06	10,02	6,63	9,59	16,55	34,03	66x28	1,92	3,27	3,41	4,11	8,51	19,93	25,04	3,08			
5,60	139x91	6,37			11,80			66x28	2,54	3,81	4,05	4,28			27,40				
5,70	139x91	6,37		8,60	8,30			66x28	2,56	3,81	4,06	4,43		20,92	27,40				
5,75	139x91	6,61	10,67	8,18				66x28	2,21	3,93	3,64						4,74		
5,80	139x91	6,64	10,67		9,02			66x28	2,54	3,81	4,05	4,55			27,40				
5,90	139x91	6,64			12,70			66x28	2,56	3,81	4,06	4,53			27,40				
6,00	139x91	4,67	10,60	6,21	9,95	16,69	34,00	66x28	2,20	3,71	3,68	4,38	8,92	20,76	27,12	3,13			
6,10	148x97	6,98			14,31			70x31	3,01	4,79	5,25	4,75		22,78	34,12				
6,20	148x97	6,98			19,16			70x31	3,01	4,79	5,25	4,69			34,12				
6,25	148x97	7,27		9,32				70x31	2,59	4,94	4,86								
6,30	148x97	7,08						70x31	3,01	4,79	5,25	4,55			34,12				
6,40	148x97	7,08						70x31	3,01	4,81	5,25	4,56			34,12				
6,50	148x97	5,99	12,11	10,18	16,46	23,66	36,59	70x31	2,58	4,42	6,57	4,70	13,61	21,70	32,81				
6,60	148x97	7,08						74x34	3,47	5,97	7,46	7,31			40,14				
6,70	148x97	7,08			14,78			74x34	3,47	5,97	7,46	7,23			40,14				
6,75	156x102	7,34	14,11	11,48				74x34	3,04	6,16	6,94								
6,80	156x102	7,33			15,48	27,02		74x34	3,02	6,14	6,99	7,58	16,79	27,37	40,14				
6,90	156x102	7,51						74x34	3,32					28,73	40,14				

PUNTE ELICOIDALI CILINDRICHE, SERIE LUNGA E EXTRA CORTA

Punte Metallo

Rosa

**DIN
340**

**DIN
1897**

		BC4	BC47	BC40	BC44	BC48	BC78										
		HSS	HSSCo 5%	HSS	HSSCo 5%	HSSCo 5%	PMD										
		118°	135°	118°	135°	135°	118°										
		30° "N"	30° "N"	30° "N"	38° "5"	38° "5"	30° "N"										
		OX	DORATO	TiN	BRILLANTE	TiAlN	BRILLANTE										
					INOX	INOX	GHISA										
		70 Kg/mm ²	120 Kg/mm ²	PRODUZIONE	INOX	INOX	GHISA										
					INOX	INOX Plus	GHISA										
		70 Kg/mm ²	120 Kg/mm ²	PRODUZIONE	INOX	INOX Plus	GHISA										
					OX	DORATO											
		ALTA PRODUZIONE	70 Kg/mm ²	120 Kg/mm ²	OX	DORATO											
		€	€	€	€	€	€	L1 x L2	€	€	€	€	€	€	€	€	€
7,00	156x102	6,84	14,22	11,24	15,07	27,31	36,59	74x34	3,02	5,07	6,99	7,65	14,63	23,81	38,56	5,03	
7,10	156x102	7,51						74x34							47,43		
7,20	156x102	7,51			22,86			74x34	3,92						47,97		
7,25	156x102	7,83						74x34	3,42	6,60	7,41						
7,30	156x102	7,67			23,99			74x34		6,94					48,90		
7,40	156x102	7,67						74x34							48,90		
7,50	156x102	7,45	15,11	11,64	17,52	28,53	41,69	74x34	3,42	6,23	7,41	9,14	17,30	25,04	44,54		
7,60	165x109	7,67						79x37		7,50					54,15		
7,70	165x109	7,67						79x37		7,50					55,17		
7,75	165x109	7,97		12,68				79x37	3,76	7,14	7,75						
7,80	165x109	8,59			26,76			79x37	4,31	7,18	8,31	9,32	26,23		54,15		
7,90	165x109	8,59						79x37		7,54					54,15		
8,00	165x109	8,22	16,16	12,55	20,24	30,40	41,69	79x37	3,73	6,39	7,71	8,96	17,11	26,72	50,74	6,15	
8,10	165x109	8,59						79x37						30,80	66,02		
8,20	165x109	8,59			25,86			79x37							67,29		
8,25	165x109	8,93						79x37	4,48	8,42	8,48						
8,30	165x109	13,09						79x37							67,29		
8,40	165x109	13,20						79x37							67,29		
8,50	165x109	9,24	18,75	14,18	21,60	34,91	52,76	79x37	4,48	7,56	8,48	10,43	20,28	29,32	65,04		
8,60	175x115	13,20						84x40		9,59				32,81	71,64		
8,70	175x115	13,20						84x40							73,03		
8,75	175x115	13,43		15,66				84x40	4,90	9,14	8,89						
8,80	175x115	13,48			26,22			84x40							71,64		
8,90	175x115	13,48						84x40							73,03		
9,00	175x115	10,02	20,21	14,91	24,27	37,38	46,11	84x40	4,86	8,30	9,51	11,35	21,51	31,24	63,23		

PUNTE ELICOIDALI CILINDRICHE, SERIE LUNGA E EXTRA CORTA

Punte Metallo

Rosa

**DIN
340**

**DIN
1897**

		BC4	BC47	BC40	BC44	BC48	BC78			BC3	BC31	BC37	BC33	BC35	BC77	BC43	BC17	BC38
MATERIALE		HSS	HSSCo 5%	HSS	HSSCo 5%	HSSCo 5%	PMD			HSS	HSSCo 5%	HSS	HSSCo 5%	HSSCo 5%	PMD	MD	HSS	HSSCo 5%
TIPO DI AFFILATURA																		
ANGOLO DI TAGLIO		118°	135°	118°	135°	135°	118°			135°	135°	135°	135°	118°	118°	135°	135°	135°
ELICA																		
FINITURA		OX	DORATO	TiN	BRILLANTE	TiAlN	BRILLANTE			OX	DORATO	TiN	BRILLANTE	TiAlN	BRILLANTE	BRILLANTE	OX	DORATO
APPLICAZIONE				PRODUZIONE	INOX	INOX	GHISA					PRODUZIONE	INOX	INOX Plus	GHISA	ALTA PRODUZIONE		
Ø mm	L1 x L2	€	€	€	€	€	€	L1 x L2	€	€	€	€	€	€	€	€	€	€
14,00	214x140	27,05					100,47	107x54	15,15	25,64	27,13	36,56		67,14	164,62			
14,25	220x144	48,75																
14,50	220x144	31,64						111x56	17,44	35,57	29,44	42,19			180,81			
14,75	220x144	48,75																
15,00	220x144	30,64					104,02	111x56	19,95	36,11	31,96	46,54		82,98	182,06			
15,25	227x149	55,00																
15,50	227x149	45,44						115x58	24,04	41,76	36,06	50,60			217,65			
15,75	227x149	55,01																
16,00	227x149	35,65					135,13	115x58	24,04	43,31	36,06	54,72		96,23	219,83			
16,25	235x154	60,69																
16,50	235x154	42,19						119x60	28,25	49,53	44,28							
16,75	235x154	60,69																
17,00	235x154	42,38					172,21	119x60	28,25	49,53	44,28							
17,25	241x158	69,77																
17,50	241x158	62,61						123x62	31,49	54,85	47,51							
17,75	241x158	81,52																
18,00	241x158	44,18					180,17	123x62	31,49	59,78	50,16							
18,25	247x162	85,26																
18,50	247x162	68,38						127x64	35,07	66,00	53,78							
18,75	247x162	118,71																
19,00	247x162	55,38						127x64	35,07	66,00	53,78							
19,25	254x166	122,90																
19,50	254x166	106,50						131x66	42,04	73,20	63,43							
19,75	254x166	120,26																
20,00	254x166	62,14					249,96	131x66	42,04	78,42	63,43				464,11			

PUNTE ELICOIDALI CILINDRICHE SERIE EXTRA LUNGA

DIN 1869 I/II/III



		BC8	BC88
MATERIALE		HSS	HSSCo 5%
TIPO DI AFFILATURA			
ANGOLO DI TAGLIO		118°	135°
ELICA		30° "N"	38° "S"
FINITURA		OX	BRILLANTE
APPLICAZIONE		70 Kg/mm²	INOX
Ø mm	L1 x L2	€	€
0,50	50x25	9,94	
0,60	60x30	10,42	
0,70	60x30	10,87	
0,70	80x50	10,87	
0,80	60x30	10,87	
0,80	80x50	10,87	
0,80	120x60	11,18	
1,00	80x50	11,59	
1,00	100x70	11,86	
1,00	150x75	11,86	
1,50	100x70	11,86	
1,50	140x100	9,58	
2,00	100x70	9,63	
2,00	125x85	9,73	15,90
2,00	150x100	9,95	
2,00	160x125		24,65
2,00	200x135		31,26
2,25	135x90		20,48
2,50	140x95	10,06	15,77
2,50	180x130		33,32
2,50	225x150		39,35
2,75	150x100		22,44
3,00	150x100	11,13	17,92
3,00	190x130	12,73	22,06
3,00	240x160		38,98
3,25	155x105		22,44
3,25	200x135		27,70
3,50	165x115	11,04	18,17
3,50	210x145	13,65	23,34
3,50	265x180	19,54	31,65
3,75	165x115		25,98
3,75	210x145		27,70
3,75	265x180		36,58
4,00	175x120	11,08	18,17
4,00	220x150	13,81	23,34
4,00	280x190	19,91	31,65
4,25	175x120		27,53
4,25	220x150	22,17	35,59
4,25	280x190		44,52
4,50	185x125	12,57	21,26
4,50	235x160	16,54	27,73
4,50	295x220	23,46	39,39

		BC8	BC88
Ø mm	L1 x L2	€	€
4,75	185x125		28,34
4,75	235x160		35,59
4,75	295x200		44,52
5,00	195x135	12,80	25,71
5,00	245x170	17,82	32,28
5,00	315x210	21,86	37,22
5,25	195x135		28,76
5,25	245x170		39,73
5,25	315x210		47,62
5,50	205x140	14,97	22,77
5,50	260x180	20,45	34,43
5,50	330x225	26,85	42,34
5,75	205x140	17,89	28,76
5,75	260x180	24,74	39,73
5,75	330x225	30,03	48,21
6,00	205x140	15,48	22,76
6,00	260x180	23,07	34,43
6,00	330x225	27,26	42,48
6,25	215x150		33,69
6,25	275x190		41,57
6,25	350x235		53,68
6,50	215x150	17,35	28,20
6,50	275x190	25,09	38,01
6,50	350x235	30,90	48,51
6,75	225x155		36,58
6,75	290x200		48,01
6,75	370x250		68,07
7,00	225x155	19,54	34,99
7,00	290x200	27,44	42,48
7,00	370x250	39,15	62,55
7,25	225x155		46,61
7,25	290x200		57,44
7,25	370x250		76,75
7,50	225x155	23,42	38,60
7,50	290x200	31,21	50,59
7,50	370x250	46,12	71,05
7,75	240x165		48,01
7,75	305x210		57,44
7,75	390x265		84,88
8,00	240x165	24,80	39,39
8,00	305x210	32,68	49,30
8,00	390x265	46,43	72,97
8,25	240x165		62,96
8,25	305x210		83,59
8,25	390x265		101,54
8,50	240x165	32,11	53,46
8,50	305x210	44,35	74,53
8,50	390x265	60,12	91,29
8,75	240x165		67,28
8,75	320x220		83,59
8,75	410x280		106,90

		BC8	BC88
Ø mm	L1 x L2	€	€
9,00	250x175	33,00	57,04
9,00	320x220	43,87	71,67
9,00	410x280	64,14	93,52
9,25	250x175		78,69
9,25	320x220		100,33
9,25	410x280		125,47
9,50	250x175	39,15	66,02
9,50	320x220	54,26	85,71
9,50	410x280	72,60	113,92
9,75	265x185		80,29
9,75	340x235		104,55
9,75	430x295		134,74
10,00	265x185	39,71	59,84
10,00	340x235	51,16	74,84
10,00	430x295	70,60	111,06
10,25	265x185		113,39
10,25	340x235		122,94
10,25	430x295		130,73
10,50	265x185	57,75	101,18
10,50	340x235	62,57	109,67
10,50	430x295	66,56	116,63
10,75	280x195		113,39
10,75	365x250		122,94
10,75	455x310		130,73
11,00	280x195	41,46	75,86
11,00	365x250	56,20	98,45
11,00	455x310	65,78	115,25
11,25	280x195		105,62
11,25	365x250		141,81
11,25	455x310		146,47
11,50	280x195	53,78	94,21
11,50	365x250	72,20	126,49
11,50	455x310	74,59	130,68
11,75	280x195		105,62
11,75	365x250		141,81
11,75	455x310		146,47
12,00	295x205	55,58	85,71
12,00	375x260	63,40	111,06
12,00	480x330	77,15	135,16
12,25	295x205		122,94
12,25	375x260		137,66
12,25	480x330		167,10
12,50	295x205	62,57	109,67
12,50	375x260	70,08	122,81
12,50	480x330	81,42	149,06
12,75	295x205		122,94
12,75	375x260		137,66
12,75	480x330		167,10
13,00	295x205	62,57	109,67
13,00	375x260	72,21	126,49
13,00	480x330	85,89	150,46

* Altre dimensioni disponibili su richiesta

PUNTA ELICOIDALE PER AERONAUTICA, SERIE EXTRA LUNGA

Punte Metallo

Rosa

Ref. BC08

HSS

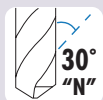
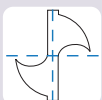

AIRCRAFT

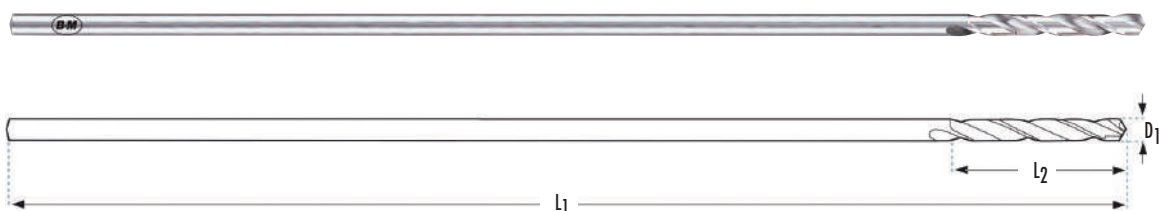

150 mm

				BC08
	D ₁ mm	L ₁ mm	L ₂ mm	€
BC080225150	2,25	150	25	13,92
BC080250150	2,50	150	25	13,42
BC080320150	3,20	150	26	13,40
BC080325150	3,25	150	36	13,21
BC080400150	4,00	150	43	13,67

300 mm

				BC08
	D ₁ mm	L ₁ mm	L ₂ mm	€
BC080225300	2,25	300	25	14,78
BC080250300	2,50	300	25	13,97
BC080320300	3,20	300	26	14,01
BC080325300	3,25	300	36	13,96
BC080400300	4,00	300	43	15,61

* Altre dimensioni disponibili su richiesta

PUNTA ELICOIDALE IN METALLO DURO PER AERONAUTICA, SERIE EXTRA LUNGA

Ref. BC08PMD

PMD

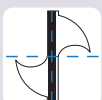
AIRCRAFT
MD

85°

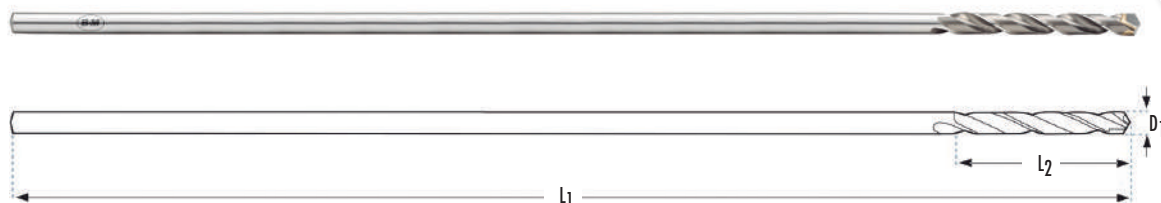

* Disponibilità serie Aircraft MD. Produzione di misure speciali su richiesta.

PUNTE A CENTRARE

Ref. BC10
Ref. BC10Co
Ref. BC65

Ref. BC10I
Ref. BC10MD
Ref. BC10W

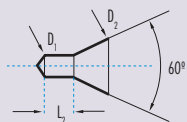

DIN
333A



DIN
333W

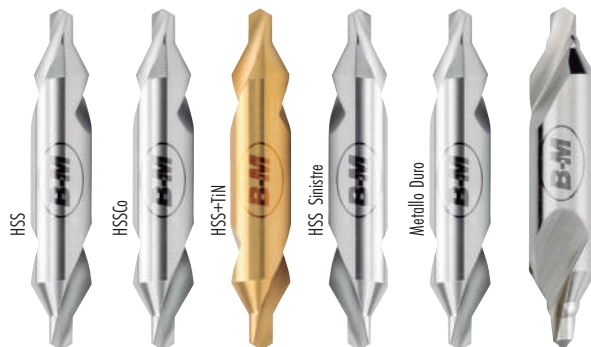
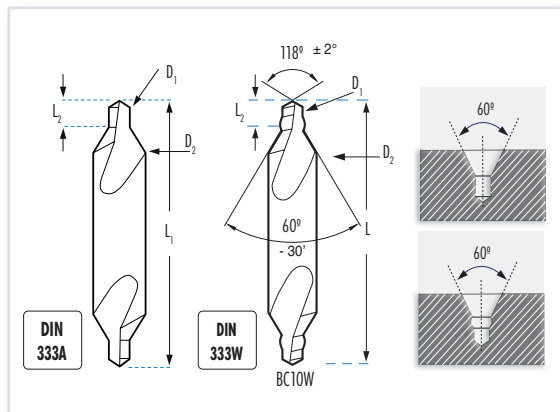

D1 x D2 mm	L1 x L2 mm	BC10	BC10Co	BC65	BC10I	BC10MD	BCW10
		HSS	HSSCo 5%	TiN	HSS	MD	HSS
		€	€	€	€	€	€
0,50 x 3,00	31 x 1	15,06		19,88			18,07
0,50 x 3,15*	25 x 1	8,85	9,61	14,74			10,62
0,63 x 3,15*	25 x 1	8,85		14,74		61,77	
0,80 x 3,15*	25 x 1	8,69	9,61	14,60			10,43
1,00 x 3,15	31 x 1	6,13	9,16	11,82		61,77	7,35
1,25 x 3,15	33 x 1	5,67	9,16	11,82		61,77	6,80
0,75 x 3,50	35 x 1	9,39	9,61	15,76			
1,00 x 4,00	35 x 1	8,09	9,61	14,48		65,09	9,70
1,25 x 4,00	35 x 1	6,51		12,62			7,81
1,50 x 5,00	40 x 2	7,77	10,35	14,40		72,53	9,32
1,60 x 4,00	37 x 2	5,95	9,16	12,27	10,40	65,98	7,14
1,60 x 5,00	40 x 2	6,48		12,82			7,77
2,00 x 5,00	42 x 2	6,59	9,86	12,93	11,51	75,18	7,91
2,00 x 6,00	45 x 2	7,77	10,90	15,69		81,10	9,32
2,00 x 6,30	45 x 2	6,65		14,46	12,96		8,84
2,50 x 6,30	47 x 3	7,32	10,95	14,64	12,79	85,67	8,79
2,50 x 8,00	50 x 3	8,09	11,49	15,36	14,11	96,13	9,70
3,00 x 8,00	50 x 3	8,49	12,11	16,38		96,13	10,18
3,15 x 8,00	52 x 4	8,06	12,05	15,42	14,08	96,13	9,68
3,00 x 10,00	55 x 4	11,03	16,75	21,07		117,41	13,24
3,15 x 10,00	56 x 4	9,52		21,07	16,63		11,42
4,00 x 10,00	59 x 5	11,18	15,95	20,71	19,51	117,41	13,41
4,00 x 12,00	63 x 5	18,96	26,41	28,06			22,75
4,00 x 12,50	63 x 5	13,02		28,06	22,73		21,79
5,00 x 12,00	63 x 5	18,96	26,41	28,06		188,00	22,75
5,00 x 12,50	66 x 6	18,04	26,31	28,82	31,50	196,09	21,64
5,00 x 14,00	69 x 6	32,60	36,49	42,63			39,12
5,00 x 16,00	71 x 6	26,94		38,79	47,10		32,33
6,30 x 16,00	74 x 8	26,81	37,66	38,79		304,29	32,17
6,30 x 18,00	77 x 8	49,62		55,86			59,54
6,30 x 20,00	80 x 8	47,26		55,86			61,43
8,00 x 20,00	81 x 27	76,85	103,00	76,47			92,22
8,00 x 25,00	100 x 10	118,53		117,55			
10,00 x 25,00	100 x 31	80,32	113,36	117,55			96,38
10,00 x 31,50	125 x 12	250,14		254,36			
12,50 x 31,50	125 x 33	191,03	248,29	254,56			



PUNTE A CENTRARE

 Ref. BC64
 Ref. BC68

**DIN
333A**
SERIE LUNGA

Ref. BC62

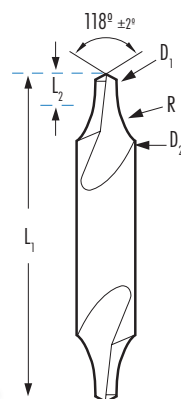
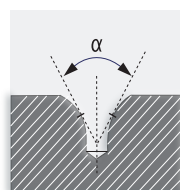
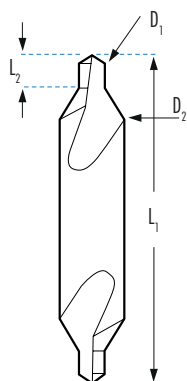
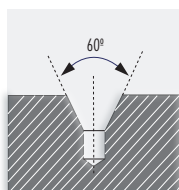
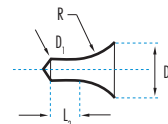
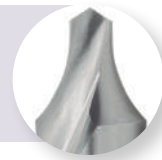
**DIN
333R**

D1 x D2 mm	L1 x L2 mm	BC64		BC68	
		HSS €	TiN €	HSS €	TiN €
1,00 x 4,00	60 x 1	20,99	26,73		
1,00 x 4,00	120 x 1	42,41	67,98		
1,50 x 5,00	60 x 2	21,41	27,08		
1,50 x 5,00	120 x 2	43,23	60,15		
2,00 x 5,00	200 x 2	92,81	157,45		
2,00 x 6,00	80 x 2	22,30	29,40		
2,00 x 6,00	120 x 2	33,78	59,46		
2,50 x 6,30	200 x 2	91,16	155,78		
2,50 x 8,00	80 x 3	27,14	38,24		
2,50 x 8,00	120 x 3	41,09	70,47		
3,00 x 8,00	80 x 4	27,14	38,24		
3,00 x 8,00	120 x 4	41,09	70,47		
3,15 x 8,00	200 x 4	86,17	150,81		
3,00 x 10,00	100 x 4	35,04	48,07		
3,00 x 10,00	120 x 4	42,45	79,75		
4,00 x 10,00	100 x 5	35,07	48,07		
4,00 x 10,00	120 x 5	42,51	79,75		
4,00 x 10,00	200 x 5	94,46	159,09		
4,00 x 12,00	100 x 5	47,25	71,82		
4,00 x 12,00	120 x 5	57,25	101,55		
5,00 x 14,00	120 x 6	80,13	122,39		

D1 x D2 mm	L1 x L2 mm	BC62		BC62MDI	
		HSS €	MD €	HSS €	MD €
0,50 x 3,00	31 x 2,3	9,55			
0,50 x 3,15	25 x 2,3	6,34	46,26		
0,80 x 3,15	25 x 2,6	6,34			
1,00 x 3,15	31 x 3,0	6,34	48,27		
1,25 x 3,15	31 x 3,3	6,34	48,27		
0,50 x 3,50	35 x 2,7	9,55			
0,75 x 3,50	35 x 2,8	6,34			
1,00 x 4,00	35 x 3,3	6,34			
1,25 x 4,00	35 x 3,7	6,37			
1,60 x 4,00	37 x 4,0	6,34	52,29		
1,50 x 5,00	40 x 4,5	7,12			
1,60 x 5,00	40 x 4,5	7,12			
2,00 x 5,00	42 x 5,0	6,88	62,34		
2,00 x 6,00	45 x 5,4	7,96			
2,00 x 6,30	45 x 6,0	7,96			
2,50 x 6,30	47 x 6,0	7,62	74,41		
2,50 x 8,00	50 x 7,0	8,47			
3,00 x 8,00	50 x 8,0	8,47			
3,15 x 8,00	52 x 8,0	8,47	90,50		
3,00 x 10,00	55 x 8,9	10,93			
3,15 x 10,00	56 x 9,0	10,93			
4,00 x 10,00	56 x 10,0	10,93	123,88		
4,00 x 12,00	63 x 10,7	18,39			
5,00 x 12,00	63 x 11,4	18,39			
4,00 x 12,50	63 x 11,0	18,39			
5,00 x 12,50	66 x 13,0	18,44	197,09		
5,00 x 14,00	69 x 12,8	25,30			
5,00 x 16,00	71 x 15,0	26,17			
6,30 x 16,00	74 x 17,0	26,22			
6,00 x 18,00	77 x 16,6	42,49			
6,30 x 20,00	80 x 19,0	46,95			
8,00 x 20,00	80 x 21,0	49,38			
10,00 x 25,00	100 x 26,0	82,55			
12,50 x 31,50	125 x 33,0	191,07			

PUNTE A CENTRARE

Ref. BC63

DIN 333B

HSS

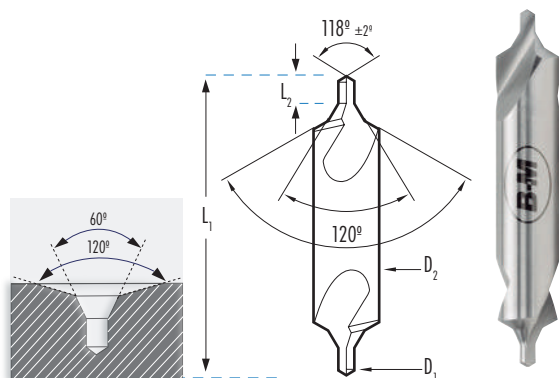
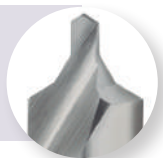

BC63

D1 x D2 mm	L1 x L2 mm	€
0,50 x 3,00	31,00 x 0,6	12,54
0,75 x 4,00	35,00 x 1,0	11,23
1,00 x 4,00	37,50 x 1,60	11,23
1,25 x 5,00	42,00 x 1,90	11,23
1,50 x 5,00	40,00 x 2,00	11,99
1,00 x 6,00	45,00 x 1,30	11,99
2,00 x 6,00	45,00 x 2,50	11,99
1,60 x 6,30	47,00 x 2,40	11,23
1,50 x 8,00	50,00 x 2,00	12,38
2,00 x 8,00	52,00 x 2,90	11,76
2,50 x 8,00	50,00 x 3,10	13,75
3,00 x 8,00	50,00 x 3,90	14,14
2,00 x 10,00	55,00 x 2,50	14,42
2,50 x 10,00	59,00 x 3,60	13,62
3,00 x 10,00	55,00 x 3,90	16,35
4,00 x 10,00	55,00 x 5,00	16,52
3,15 x 11,20	63,00 x 4,40	15,73
2,50 x 12,00	63,00 x 3,10	21,27
4,00 x 12,00	63,00 x 5,00	21,85
5,00 x 12,00	63,00 x 6,30	23,23
3,00 x 14,00	69,00 x 3,90	26,70
4,00 x 14,00	70,00 x 5,60	23,23
5,00 x 14,00	69,00 x 6,30	31,63
4,00 x 16,00	71,00 x 5,00	34,03
4,00 x 18,00	77,00 x 5,00	37,50
5,00 x 18,00	78,00 x 6,90	33,45
6,00 x 18,00	77,00 x 8,00	44,74
5,00 x 20,00	80,00 x 6,30	63,54
6,30 x 20,00	83,00 x 8,60	48,79
6,00 x 25,00	100,00 x 8,00	113,06
6,30 x 25,00	100,00 x 8,00	113,06
8,00 x 25,00	100,00 x 26,00	107,77
10,00 x 31,50	125,00 x 30,00	213,58

PUNTE A CENTRARE CILINDRICHE

Ref. BC75
Ref. BI75
Ref. BC76

HSSCo 5%

TiAlN

DIN 1412A

D₂

TOL h6

Utilizzate per centrare prima di trapanare con la punta. Prepara il foro della punta. Aumenta la velocità d'attacco durante la perforazione.

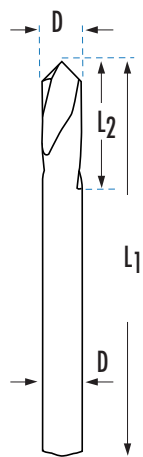

BC75 BI75 BC76 BH75

D mm	L1 x L2 mm	90°	90°	120°	142°
		€	€	€	€
2,0	49 x 8	12,50		12,50	
3,0	50 x 10	11,87	71,18	11,87	27,90
4,0	52 x 12	13,15	75,92	13,15	27,90
5,0	60 x 15	14,20	80,66	14,20	31,46
6,0	66 x 20	16,20	85,42	16,20	31,46
8,0	79 x 25	22,45	94,89	22,45	35,53
10,0	89 x 25	22,56	106,76	22,56	35,53
12,0	102 x 30	31,27	118,61	31,27	49,01
16,0	115 x 35	64,77		64,77	67,41
20,0	131 x 40	84,64		84,64	132,65

PUNTA DA CENTRO A DOPPIA PUNTA

Ref. DP75

HSSCo 5%

TiAlN

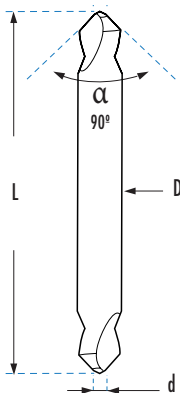

D x d mm	L mm	90°
		€
3,0 x 0,5	40	28,81
4,0 x 1,0	45	28,93
6,0 x 2,0	55	32,80
8,0 x 2,5	65	37,90
10,0 x 3,0	75	40,66
12,0 x 3,5	85	50,17
16,0 x 4,0	90	77,28
20,0 x 5,0	100	126,76



PUNTE A CENTRARE CILINDRICHE

Utilizzate per centrare prima di trapanare con la punta. Prepara il foro della punta.
Aumenta la velocità d'attacco durante la perforazione.

DIN
1412A
D₂
TOL
h6
PUNTA DA CENTRO IN METALLO DURO

 Ref. BC92
 Ref. BC93

MD

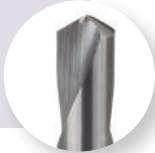
DIN
1412A
TOL
h6
DIN
6535HB

D mm	L1 x L2 mm	BC92		BC93	
		90° €	120° €	90° €	120° €
1,0	26 x 6	24,98			
1,5	32 x 9	25,35			
2,0	38 x 12	25,62			
3,0	45 x 12	25,98	25,98		
4,0	50 x 15	26,24	29,15		
5,0	50 x 18	31,26	31,26		
6,0	50 x 13	40,99	40,99		
8,0	60 x 23	57,69	57,69		
10,0	70 x 24	81,78	81,78		
12,0	70 x 24	105,62	105,62		
14,0	70 x 27	157,28	157,28		
16,0	75 x 29	194,34	194,34		
18,0	100 x 33	286,43	286,43		
20,0	100 x 35	344,61	344,61		

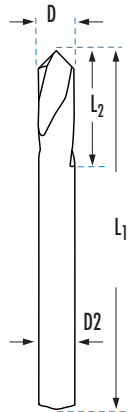
PUNTA A CENTRARE MULTIUSO

Ref. BN75

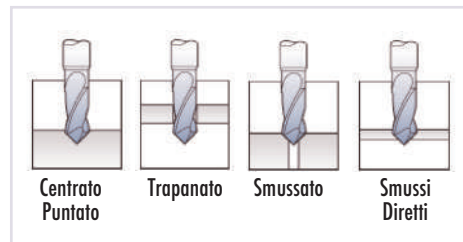
HSSCo
5%
120
Kg/mm²

	D mm	L1 x L2 mm	T* mm	BN75	
				90° €	
BN750300	3,0	50 x 6	0,3	34,09	
BN750400	4,0	52 x 8	0,4	36,97	
BN750500	5,0	60 x 10	0,5	40,14	
BN750600	6,0	66 x 12	0,6	43,01	
BN750800	8,0	79 x 14	0,8	51,93	
BN751000	10,0	89 x 16	1,0	62,13	
BN751200	12,0	102 x 18	1,2	81,24	
BN751400	14,0	115 x 21	1,4	114,69	
BN751600	16,0	115 x 24	1,6	127,44	



T*: Spessore in punta del nocciolo

PUNTE A CENTRARE SERIE LUNGA

Ref. BL75

HSSCo
5%

TiAIN

90°

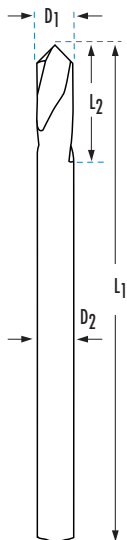

D1 mm	L1 x L2 mm	BL75	
		€	
3,0	80 x 10	47,45	
4,0	100 x 12	52,20	
5,0	120 x 15	56,94	
6,0	140 x 20	61,69	
8,0	140 x 25	68,80	
10,0	170 x 25	85,42	
12,0	170 x 30	104,39	
16,0	200 x 35	139,98	
20,0	200 x 40	177,93	

PUNTE A CENTRARE CON CODOLO CONICO

Ref. BP11

HSSCo
5%
120
Kg/mm²

90°



D1 mm	L1 mm	L2 mm	L3 mm	CM	BP11	
					€	
10,0	130	25	64	1	142,35	
12,0	130	30	64	1	154,22	
16,0	148	35	68	2	189,81	
20,0	148	40	68	2	237,26	
25,0	171	45	72	3	320,29	

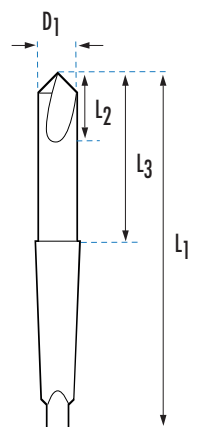

PUNTE PER RIMOUVERE LE SALDATURE

PUNTA CORTA PER MACCHINE PNEUMATICHE

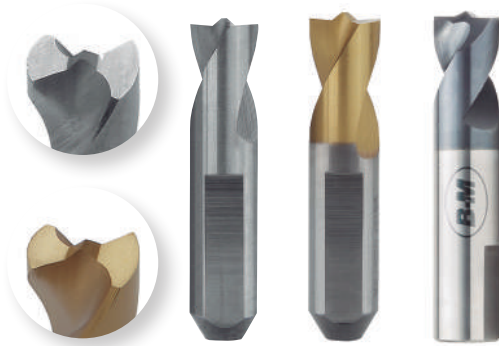

D1 mm	D2 mm	L1 x L2 mm	BC70	BC71	BC70MD*
			HSSCo 8%	HSSCo 8% TiN	MD TiAlN
			€	€	€
6,0	8,0	45 x 18	25,76	33,50	
6,5	6,5	40 x 18	24,71	38,36	77,64
8,0	8,0	38 x 18	21,25	33,50	
8,0	8,0	45 x 18	23,71	38,36	84,74
9,0	8,0	45 x 18	27,14	43,74	
10,0	8,0	45 x 18	29,76	48,03	

PUNTA LUNGA PER MACCHINE ELETTROPORATILI

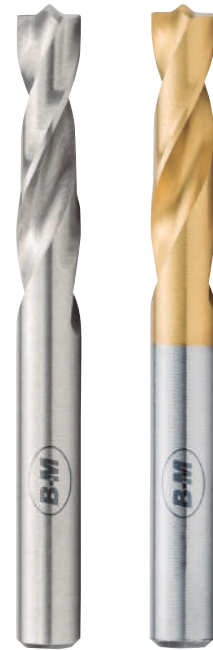

Ø mm	L1 x L2 mm	BC60	BC69
		HSSCo 5%	HSSCo 5% TiN
		€	€
6,0	66 x 26	11,99	21,43
7,0	74 x 34	17,52	27,89
8,0	79 x 36	16,36	30,21
10,0	89 x 44	20,60	31,93

* PUNTA SPECIALE BC70MD METALLO DURO + TiAlN

- Punta speciale per saldature al boro.
- Utilizzare con trapani elettrici, non pneumatici.
- 1200 RPM.
- Alta forza propulsiva.
- Sempre con "CUT-MAGIC".

INSIEME DA TAGLIO: ALBERO, CORONA E PUNZONE



EBC70-1
23,50 €

CORONA DA TAGLIO: DI 9,5 mm



EBC70-2
16,98 €

PUNZONE



EBC70-3
1,04 €



EBC70

Composizione:

- 1 Insieme da taglio Ref. EBC70-1
- 5 Corone da taglio di 9,5 mm Ref. EBC70-2
- 2 Punzoni Ref. EBC70-3
- 1 Punta Ref. BC60 Ø 8 mm

106,53 €

PUNTE-FRESE

PER TRAPANARE E CONTORNARE LEGNO, LAMIERA E PLASTICA



* Punta speciale per carrozzieri

Ø mm	L1 x L2 mm	BC80	BC81
		HSS €	TiN €
6,0	90 x 60	18,08	28,36
8,0	90 x 60	23,25	36,30

PUNTA-FRESA IN METALLO DURO

Ref. BC91

MD

Utilizzate per trapanare, centrare, fresare e svasare.



50
HRc

Ti

INC

Ni

INOX

PVC

D2
TOL h6

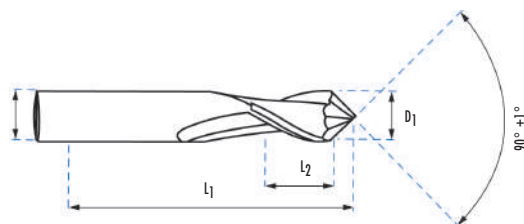

D1
TOL h9



BC91			
D1 mm	D2 mm	L1 x L2 mm	€
3,0	3,0	50 x 6	88,63
4,0	4,0	50 x 8	91,94
5,0	5,0	50 x 10	100,09
6,0	6,0	60 x 12	118,20
8,0	8,0	70 x 16	164,16
10,0	10,0	70 x 18	206,87
12,0	12,0	70 x 20	206,87
14,0	14,0	88 x 30	246,76
16,0	16,0	80 x 26	295,49
20,0	20,0	100 x 32	522,03

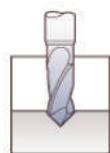

Centrato
Puntato



Fessura in V



Meccanizzato per
interpolazione



Trapanato

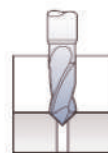

Smussato

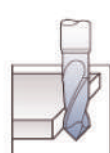

Contornato



Smussi Longitudinali

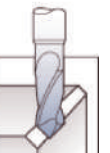

Smussi Diretti



Marcato

FLUO-PUNTE PER FILETTARE PARETI SOTTILI

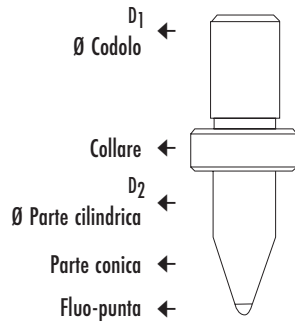
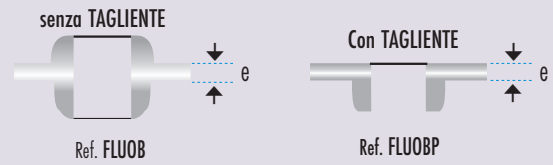

	e max. mm	D1 mm	D2 mm	R.P.M.	FLUOB		FLUOBP	
						€		€
M3x0,50	1,7	6	2,7	3000	FLUOBM03	136,50	FLUOBPM03	191,10
M4x0,70	1,7	6	3,7	2600	FLUOBM04	141,45	FLUOBPM04	198,05
M5x0,80	2,0	8	4,5	2500	FLUOBM05	147,73	FLUOBPM05	206,84
M6x1,00	2,0	8	5,3	2400	FLUOBM06	157,48	FLUOBPM06	220,47
M8x1,25	2,4	8	7,3	2200	FLUOBM08	194,29	FLUOBPM08	272,03
M10x1,50	2,6	10	9,2	2000	FLUOBM10	220,19	FLUOBPM10	308,27
M12x1,75	3,0	12	10,9	1800	FLUOBM12	231,71	FLUOBPM12	324,40
M16x2,00	3,4	16	14,8	1200	FLUOBM16	319,59	FLUOBPM16	415,91
M20x2,50	3,8	18	18,7	800	FLUOBM20	451,13	FLUOBPM20	586,32

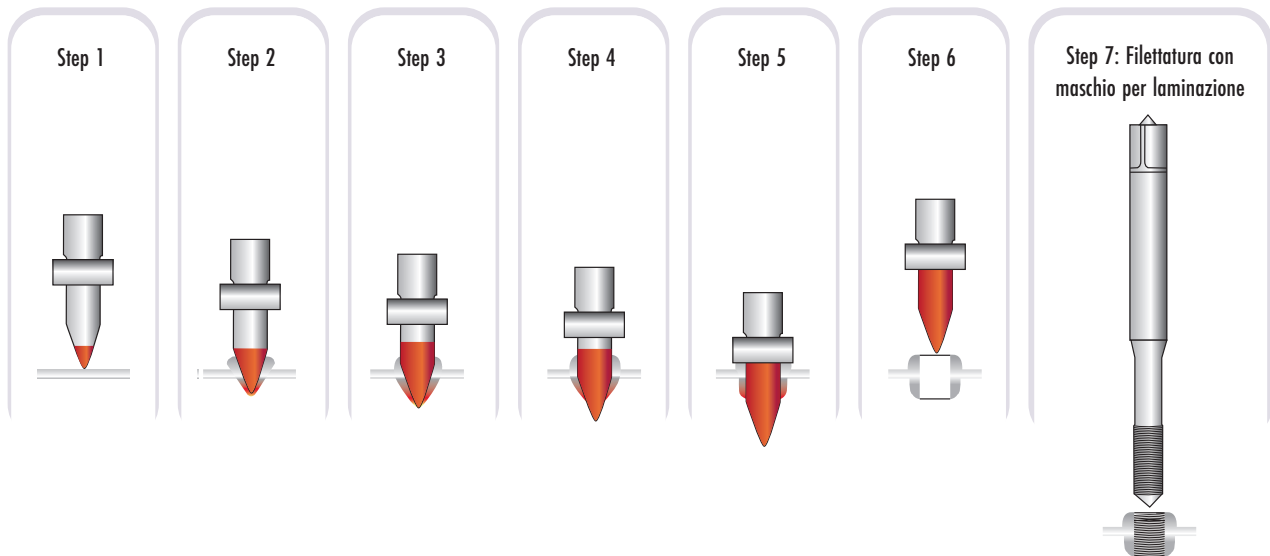

CUT MAGIC PASTY (250ml.e 750ml.)

			PASTY
		UNITÀ DI IMBALLAGGIO	€
ACPU00250	0,250 l.	1 Lotta	28,92
ACPU00750	0,750 l.	1 Lotta	43,76



Ref. ACPU00250

Ref. ACPU00750

PUNTE A DOPPIO DIAMETRO HSS
CODOLO CILINDRICO E CODOLO CONICO

Ref. BC26

HSS **DIN 8376** **180°**

SEDE ALLEN

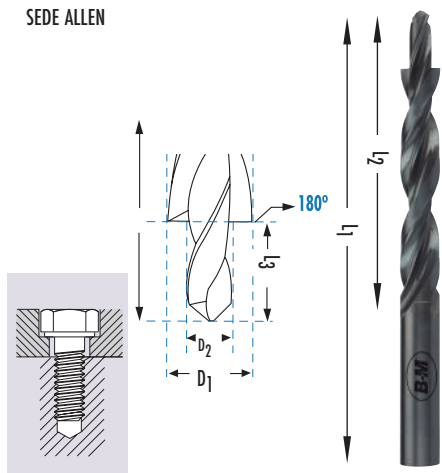
**BC26**

	D2 mm	D1 mm	L1 x L2 mm	L3 mm	€
M3	3,4	6	93 x 57	9	52,08
M4	4,5	8	117 x 75	11	54,62
M5	5,5	10	133 x 87	13	65,51
M6	6,6	11	142 x 94	15	73,36
M8	9,0	15	169 x 114	19	90,11
M10	11,0	18	191 x 130	23	179,08

Ref. BC24

HSS **DIN 8374** **90°**

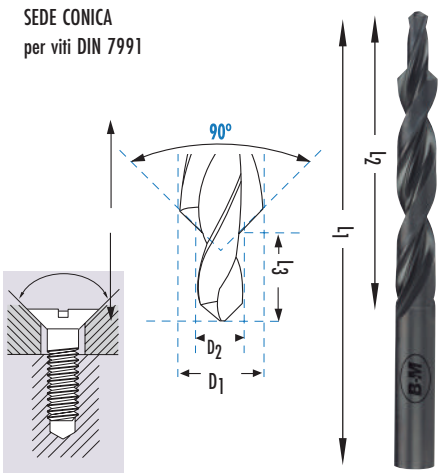
SEDE CONICA
per viti DIN 7991**BC24**

	D2 mm	D1 mm	L1 x L2 mm	L3 mm	€
M3	3,2	6,0	93 x 57	9	60,76
M4	4,3	8,0	117 x 75	11	63,72
M5	5,3	10,0	133 x 87	13	75,74
M6	6,4	11,5	142 x 94	15	86,50
M8	8,4	15,0	169 x 114	19	118,34
M10	10,5	19,0	198 x 135	23	182,72

Ref. BC28

HSS **DIN 8378** **90°**

Trapanare prima di filettare

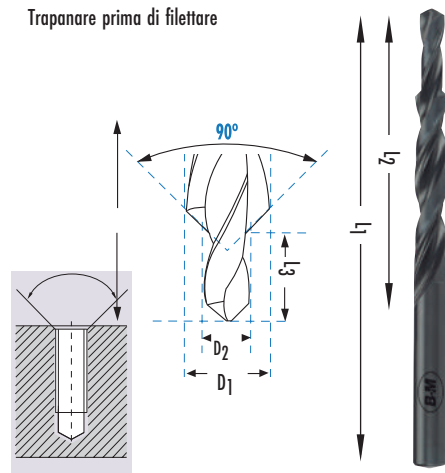
**BC28**

	D2 mm	D1 mm	L1 x L2 mm	L3 mm	€
M3	2,5	3,4	70 x 39	8,8	47,14
M4	3,3	4,5	80 x 47	11,8	50,73
M5	4,2	5,5	93 x 57	13,6	54,65
M6	5,0	6,6	101 x 63	16,5	62,16
M8	6,8	9,0	125 x 81	21,0	74,07
M10	8,5	11,0	142 x 94	25,5	86,42
M12	10,2	13,5	160 x 108	30,0	107,59

Ref. BC27

HSS **DIN 8377** **180°**

SEDE ALLEN

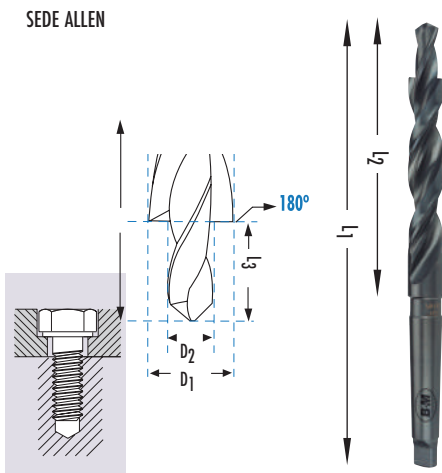
**BC27**

	D2 mm	D1 mm	L1 x L2 mm	L3 mm	CM	€
M6	6,6	11	175 x 94	15	1	146,15
M8	9,0	15	212 x 114	19	2	150,94
M10	11,0	18	228 x 130	23	2	170,18
M12	13,5	20	238 x 140	27	2	190,35
M14	15,5	24	281 x 160	31	3	269,92
M16	17,5	26	286 x 165	35	3	384,89
M18	20,0	30	296 x 175	39	3	430,41
M20	22,0	33	334 x 185	43	4	486,65

Ref. BC25

HSS **DIN 8375** **90°**

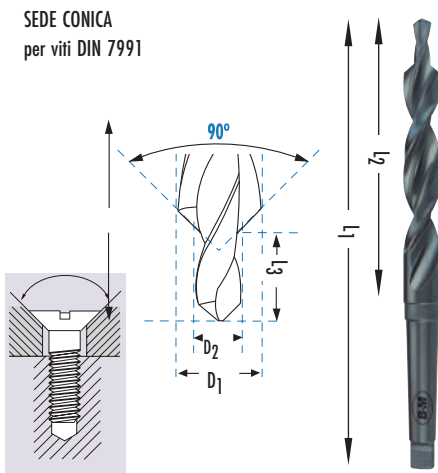
SEDE CONICA
per viti DIN 7991**BC25**

	D2 mm	D1 mm	L1 x L2 mm	L3 mm	CM	€
M5	5,5	11,0	175 x 94	13	1	146,00
M6	6,6	13,0	182 x 101	15	1	148,96
M8	9,0	17,2	228 x 130	19	2	177,53
M10	11,0	21,5	248 x 150	23	2	210,17

Ref. BC29

HSS **DIN 8379** **90°**

Trapanare prima di filettare

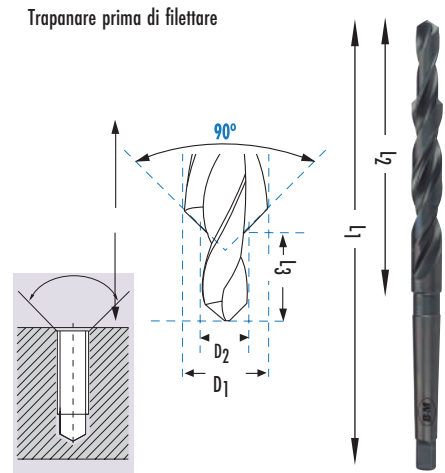
**BC29**

	D2 mm	D1 mm	L1 x L2 mm	L3 mm	CM	€
M8	6,8	9,0	162 x 81	21,0	1	133,92
M10	8,5	11,0	175 x 94	25,5	1	145,90
M12	10,2	13,5	189 x 108	30,0	1	172,35
M14	12,0	15,5	218 x 120	34,5	2	183,92
M16	14,0	17,5	228 x 130	38,5	2	198,48
M18	15,5	20,0	238 x 140	43,5	2	222,00
M20	17,5	22,0	248 x 150	47,5	2	268,43

PUNTE EXTRA CORTE A GRADINO

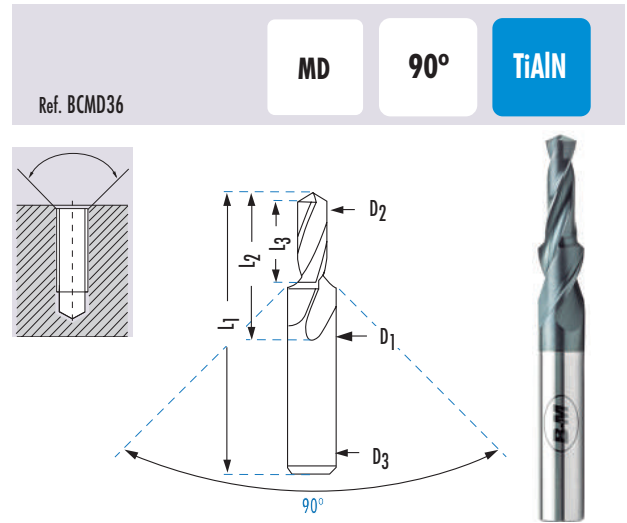
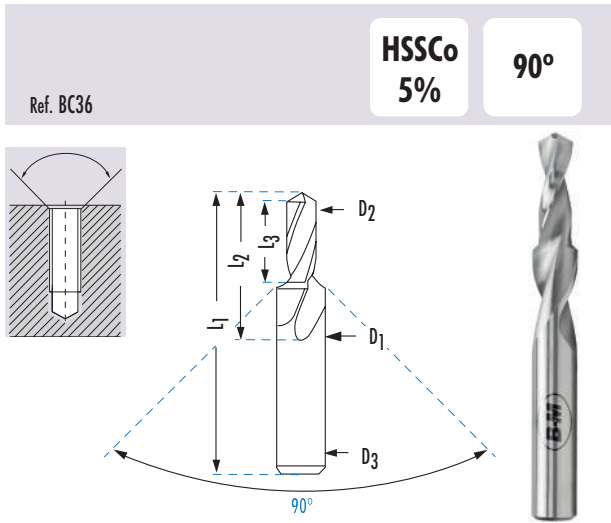

BC36

	D1 mm	D2 mm	D3 mm	L1 x L2 mm	L3 mm	€
M3	3,4	2,5	3,4	52 x 20	8	27,07
M4	4,5	3,3	4,5	58 x 24	11	27,76
M5	5,5	4,2	5,5	66 x 28	13	30,87
M6	6,6	5,0	6,6	70 x 31	16	33,55
M8	9,0	6,8	9,0	84 x 40	20	40,27
M10	11,0	8,5	11,0	95 x 47	24	53,01
M12	14,0	10,2	14,0	107 x 54	29	71,13
M14	16,0	12,0	16,0	115 x 56	32	181,20
M16	18,0	14,0	18,0	135 x 60	34	228,17

BCMD36

	D1 mm	D2 mm	D3 mm	L1 x L2 mm	L3 mm	€
M3	6,0	2,5	6,0	66 x 20	8,8	53,69
M4	6,0	3,3	6,0	66 x 24	11,4	62,63
M5	6,0	4,2	6,0	66 x 28	13,6	67,10
M6	8,0	5,0	8,0	79 x 31	16,5	78,29
M8	10,0	6,8	10,0	89 x 40	21,0	107,37
M10	12,0	8,5	12,0	102 x 47	25,5	145,42
M12	14,0	10,2	14,0	107 x 54	30,0	201,32

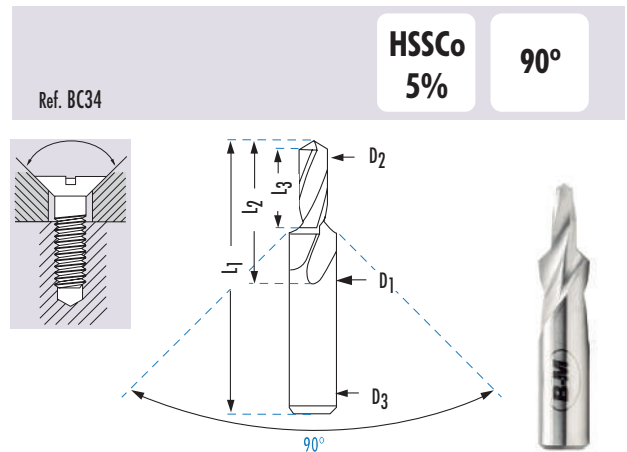
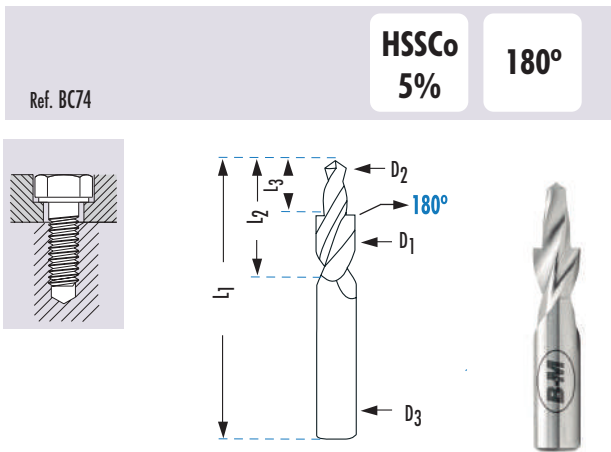

BC74

	D1 mm	D2 mm	D3 mm	L1 x L2 mm	L3 mm	€
M2	4,3	2,4	4,3	45 x 12	6	20,63
M3	6,0	3,4	6,0	45 x 18	9	20,98
M4	8,0	4,5	8,0	50 x 22	11	24,91
M5	10,0	5,5	10,0	55 x 26	13	27,75
M6	11,0	6,6	11,0	63 x 30	15	34,86
M8	15,0	9,0	12,5	100 x 34	19	65,45
M10	18,0	11,0	12,5	110 x 42	23	95,32
M12	20,0	14,0	12,5	110 x 34	28	125,20
M14	24,0	16,0	12,5	120 x 42	34	253,24

BC34

	D1 mm	D2 mm	D3 mm	L1 x L2 mm	L3 mm	€
M2	4,6	2,2	4,6	45 x 12	6	20,63
M3	6,5	3,2	6,5	45 x 18	9	20,98
M4	8,6	4,3	8,6	50 x 26	11	24,91
M5	10,4	5,3	10,4	55 x 30	13	27,75
M6	12,4	6,4	12,4	63 x 34	15	34,86
M8	16,4	8,4	12,5	100 x 42	19	65,45
M10	20,4	10,5	12,5	110 x 34	23	95,32
M12	25,0	13,0	12,5	120 x 42	28	253,24

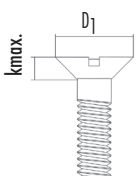

DIN 7991

	M2	M2.5	M3	M4	M5	M6	M8	M10	M12	M14	M16	M18	M20
Kmax.	1,2	1,5	1,7	2,3	2,8	3,3	4,4	5,5	6,5	7	7,5	8	8,5
D1	4	5	6	8	10	12	16	20	24	27	30	33	36

PUNTE ELICOIDALI CON CODOLO CONICO DIN 345
**DIN
345**

Per praticare fori superiori a Ø25 mm si consiglia di realizzare un preforo di un terzo del diametro finale.

Esempio; se utilizzerà una punta di Ø30 mm, realizzi un preforo di Ø10 mm.

			BC11	BC22	BC32	BC21	BC13
Ø mm	L1 x L2 mm	CM	€	€	€	€	€
10,75	175 x 94	1	31,78				
11,00	175 x 94	1	28,61	60,86		47,61	85,81
11,25	175 x 94	1	34,93				
11,50	175 x 94	1	30,39	67,45		48,86	88,93
11,75	175 x 94	1	34,94				
12,00	182 x 101	1	30,53	59,08		36,12	89,58
12,25	182 x 101	1	36,61				
12,50	182 x 101	1	30,77	62,29		50,40	93,02
12,75	182 x 101	1	36,62				
13,00	182 x 101	1	32,08	62,23	81,36	51,47	105,90
13,25	189 x 101	1	40,52				
13,50	189 x 101	1	33,85	66,15	98,33	53,10	105,61
13,75	189 x 101	1	45,58				
14,00	189 x 108	1	38,11	70,13	93,47	42,66	111,02
14,25	212 x 114	2	43,87				
14,50	212 x 114	2	38,13	107,47	114,70	71,26	115,03
14,75	212 x 114	2	43,86				
15,00	212 x 114	2	42,90	108,30	109,04	71,26	130,17
15,25	218 x 120	2	50,77				
15,50	218 x 120	2	44,16	113,39	112,53	73,33	138,64
15,75	218 x 120	2	50,77	131,71	140,65		
16,00	218 x 120	2	44,39	112,91	112,53	48,37	138,55
16,25	223 x 125	2	51,03				
16,50	223 x 125	2	44,59	101,15	119,44	74,82	133,43
16,75	223 x 125	2	51,03				
17,00	223 x 125	2	44,59	113,87	119,44	74,44	147,25
17,25	228 x 130	2	56,51				
17,50	228 x 130	2	49,32	122,93	126,35	80,18	147,05
17,75	228 x 130	2	63,56	153,67	168,78		
18,00	228 x 130	2	53,29	117,39	135,03	55,21	159,17
18,25	233 x 135	2	62,13				
18,50	233 x 135	2	54,28	122,32	140,22	82,15	186,03
18,75	233 x 135	2	62,55				
19,00	233 x 135	2	54,47	127,12	140,22	69,14	185,75
19,25	238 x 140	2	67,66				
19,50	238 x 140	2	58,88	131,60	147,13	88,02	208,62
19,75	238 x 140	2	68,09				
20,00	238 x 140	2	58,94	140,73	147,13	72,72	209,12
20,25	243 x 145	2	79,27				
20,50	243 x 145	2	68,71	153,91	171,37	89,36	212,50
20,75	243 x 145	2	79,27				
21,00	243 x 145	2	68,71	166,87	171,37	88,95	212,50
21,25	248 x 150	2	87,47				
21,50	248 x 150	2	75,77	179,89	186,95	94,10	231,67
21,75	248 x 150	2	87,47	224,85	233,70		
22,00	248 x 150	2	75,92	180,94	186,95	84,69	231,67
22,00*	265 x 150	3	103,20				
22,25	248 x 150	2	85,11				
22,50	253 x 155	2	79,99	202,95	197,33	102,47	232,05
22,75	253 x 155	2	106,38				
23,00	253 x 155	2	92,08	197,49	214,63	101,72	251,69
23,25	276 x 155	3	93,86				
23,50	276 x 155	3	95,95	228,35	258,77	122,58	256,34
23,75	281 x 160	3	93,98				
24,00	281 x 160	3	101,97	193,38	238,89	105,10	276,64

	BC11	BC22	BC32	BC21	BC13
MATERIALE	HSS	HSSCo 5%	HSSCo 5%	HSS	PMD
TIPO DI AFFILATURA					
ANGOLO DI TAGLIO	118°	135°	135°	118°	118°
ELICA	30° "N"	30° "N"	38° "N"	30° "N"	30° "N"
FINITURA	OX	OX	OX	TiN	BRILLANTE
APPLICAZIONE	70 Kg/mm²	120 Kg/mm²	INOX	PRODUZIONE	GHISA
Ø mm	L1 x L2	CM	€	€	€
3,00	114 x 33	1	40,66		
3,50	120 x 43	1	40,21		
4,00	124 x 43	1	40,84		
4,50	128 x 47	1	43,46		
5,00	133 x 52	1	25,60		
5,25	133 x 52	1	29,43		
5,50	138 x 57	1	25,60		
5,75	138 x 57	1	29,43		
6,00	138 x 57	1	25,60		
6,25	144 x 63	1	33,54		
6,50	144 x 63	1	27,18		
6,75	150 x 69	1	31,32		
7,00	150 x 69	1	27,06		
7,25	150 x 69	1	35,97		
7,50	150 x 69	1	23,39		
7,75	156 x 75	1	28,78		
8,00	156 x 75	1	23,26	44,47	
8,25	156 x 75	1	33,85		
8,50	156 x 75	1	25,27	44,97	
8,75	162 x 81	1	30,35		
9,00	162 x 81	1	25,28	44,77	
9,25	162 x 81	1	33,44		
9,50	162 x 81	1	27,25	44,77	
9,75	168 x 87	1	35,55		
10,00	168 x 87	1	26,11	59,04	44,39
10,25	168 x 87	1	30,79		82,39
10,50	168 x 87	1	27,58	71,73	46,67
					81,92

Cono rinforzato, DIN 346, su richiesta

PUNTE ELICOIDALI CON CODOLO CONICO DIN 345

**DIN
345**



Per praticare fori superiori a Ø25 mm si consiglia di realizzare un preforo di un terzo del diametro finale.

Esempio; se utilizzerà una punta di Ø30 mm, realizzi un preforo di Ø10 mm.

			BC11	BC22	BC32	BC21	BC13							
Ø mm	L1 x L2 mm	CM	€	€	€	€	€	Ø mm	L1 x L2 mm	CM	€	€	€	€
31,00	301x180	3	165,99	303,83		196,03		31,00	301x180	3	165,99	303,83	196,03	
31,25	301x180	3	201,98					31,25	301x180	3	201,98			
31,50	301x180	3	174,54	466,71				31,50	301x180	3	174,54	466,71		
31,75	306x185	3	224,42		566,90			31,75	306x185	3	224,42		566,90	
32,00	334x185	4	178,72	466,16	453,51	205,12	539,92*	32,00	334x185	4	178,72	466,16	453,51	205,12
32,00	334x185	3	325,59					32,00	334x185	3	325,59			
32,25	334x185	4	235,74					32,25	334x185	4	235,74			
32,50	334x185	4	200,83					32,50	334x185	4	200,83			
32,75	334x185	4	235,74					32,75	334x185	4	235,74			
33,00	334x185	4	199,64	537,97		223,26	650,18*	33,00	334x185	4	199,64	537,97		223,26
33,25	334x185	4	246,24					33,25	334x185	4	246,24			
33,50	334x185	4	217,81					33,50	334x185	4	217,81			
33,75	339x190	4	247,58					33,75	339x190	4	247,58			
34,00	339x190	4	217,14	594,94		317,26	657,49*	34,00	339x190	4	217,14	594,94		317,26
34,25	339x190	4	270,58					34,25	339x190	4	270,58			
34,50	339x190	4	237,15					34,50	339x190	4	237,15			
34,75	339x190	4	270,58	646,81				34,75	339x190	4	270,58	646,81		
35,00	339x190	4	238,33	636,94	621,38	349,82		35,00	339x190	4	238,33	636,94	621,38	349,82
35,25	339x190	4	289,98					35,25	339x190	4	289,98			
35,50	339x190	4	254,41					35,50	339x190	4	254,41			
35,75	344x195	4	297,75					35,75	344x195	4	297,75			
36,00	344x195	4	255,05	684,30		363,06	1.045,94*	36,00	344x195	4	255,05	684,30		363,06
36,25	344x195	4	312,94					36,25	344x195	4	312,94			
36,50	344x195	4	269,74					36,50	344x195	4	269,74			
36,75	344x195	4	312,92					36,75	344x195	4	312,92			
37,00	344x195	4	269,39	701,25		373,65	1.129,70*	37,00	344x195	4	269,39	701,25		373,65
37,25	344x195	4	333,53					37,25	344x195	4	333,53			
37,50	344x195	4	335,54					37,50	344x195	4	335,54			
37,75	344x195	4	361,85					37,75	344x195	4	361,85			
38,00	349x200	4	282,92	724,46		384,33		38,00	349x200	4	282,92	724,46		384,33
38,25	349x200	4	391,62					38,25	349x200	4	391,62			
38,50	349x200	4	334,53					38,50	349x200	4	334,53			
38,75	349x200	4	391,62					38,75	349x200	4	391,62			
39,00	349x200	4	334,79	741,31		398,73	1.249,23*	39,00	349x200	4	334,79	741,31		398,73
39,25	349x200	4	393,91					39,25	349x200	4	393,91			
39,50	349x200	4	354,58					39,50	349x200	4	354,58			
39,75	349x200	4	393,91					39,75	349x200	4	393,91			
40,00	349x200	4	354,10	863,14		411,68	1.288,67*	40,00	349x200	4	354,10	863,14		411,68
40,50	354x205	4	371,20					40,50	354x205	4	371,20			
41,00	354x205	4	371,67	907,35				41,00	354x205	4	371,67	907,35		
41,50	354x205	4	395,05					41,50	354x205	4	395,05			
42,00	354x205	4	394,25	950,04				42,00	354x205	4	394,25	950,04		
42,50	354x205	4	414,31					42,50	354x205	4	414,31			
43,00	359x210	4	414,33	996,19				43,00	359x210	4	414,33	996,19		
43,50	359x210	4	433,79					43,50	359x210	4	433,79			
44,00	359x210	4	434,08	1.034,41				44,00	359x210	4	434,08	1.034,41		
44,50	359x210	4	453,97					44,50	359x210	4	453,97			
45,00	359x210	4	454,32	1.081,75				45,00	359x210	4	454,32	1.081,75		
45,50	364x215	4	472,05					45,50	364x215	4	472,05			
46,00	364x215	4	470,08					46,00	364x215	4	470,08			
46,50	364x215	4	491,32					46,50	364x215	4	491,32			
47,00	364x215	4	491,09	1.168,83				47,00	364x215	4	491,09	1.168,83		
47,50	364x215	4	507,82					47,50	364x215	4	507,82			
48,00	369x220	4	507,46	1.217,82				48,00	369x220	4	507,46	1.217,82		
48,50	369x220	4	527,99					48,50	369x220	4	527,99			

Cono rinforzato, DIN 346, su richiesta

*Fino ad esaurimento scorte.

PUNTA ELICOIDALE CON CODOLO CONICO DIN 345

Ref. BC11

**DIN
345**
HSS

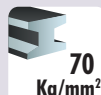
OX

Punte Metallo

Grigio



BC11

Ø mm	L1 x L2 mm	CM	€
49,00	369x220	4	525,76
49,50	369x220	4	542,30
50,00	369x220	4	548,12
50,50	369x220	4	784,86
51,00	412x225	5	642,73
51,50	412x225	5	861,45
52,00	412x225	5	686,91
52,50	412x225	5	882,43
53,00	412x225	5	735,68
53,50	412x225	5	923,09
54,00	417x230	5	809,56
54,50	417x230	5	913,84
55,00	417x230	5	801,43
56,00	417x230	5	901,78
57,00	422x235	5	957,99
58,00	422x235	5	966,18
59,00	422x235	5	995,18
60,00	422x235	5	942,06
61,00	427x240	5	1.105,02
62,00	427x240	5	1.150,88
63,00	427x240	5	1.217,12
64,00	432x245	5	1.284,15
65,00	432x245	5	1.229,58
66,00	432x245	5	1.330,84
67,00	432x245	5	1.431,00
68,00	437x250	5	1.468,11
69,00	437x250	5	1.513,76
70,00	437x250	5	1.435,27
71,00	437x250	5	1.657,08
72,00	442x255	5	1.691,40
73,00	442x255	5	1.735,67
74,00	442x255	5	1.786,47
75,00	442x255	5	1.682,77
76,00	447x260	5	1.981,48
77,00	514x260	6	2.126,37
78,00	514x260	6	2.167,91
79,00	514x260	6	2.211,59
80,00	514x260	6	2.783,70
81,00	519x265	6	3.080,41
82,00	519x265	6	3.157,40
83,00	519x265	6	3.217,95
84,00	519x265	6	3.286,25
85,00	519x265	6	3.367,44
86,00	524x270	6	3.440,96
87,00	524x270	6	3.514,04
88,00	524x270	6	3.604,36
89,00	524x270	6	3.674,11
90,00	524x270	6	3.779,27
91,00	529x275	6	3.986,03
92,00	529x275	6	4.009,00
93,00	529x275	6	4.151,98
94,00	529x275	6	4.236,32
95,00	529x275	6	4.323,38
96,00	534x280	6	4.465,81
97,00	534x280	6	4.503,28
98,00	534x280	6	4.603,73
99,00	534x280	6	4.686,99
100,00	534x280	6	4.776,39



Ref. EXPBC11MC

ESPOSITORE 15 PUNTE CODOLO CONICO

Cono Morse	14	15	16	17	18	DIN
n° 1	1	1	1	1	1	345
n° 2	19	20	21	22	23	
	1	1	1	1	1	
n° 3	24	25	26	28	30	
	1	1	1	1	1	

Dimensioni: larghezza 280 x profondità 212/50 x altezza 155 mm

1.170,56 €

SOVRAPPREZZO PER RIDURRE CODOLI CONICI

n° 2-1

n° 2-0

n° 3-2

n° 3-1

n° 4-3

n° 4-2

€ NETTI

53,30

79,95

Cono rinforzato, DIN 346, su richiesta

Lunghezza massima 370 mm per incavo cono morse

PUNTA CON CODOLO CONICO PER FORARE MATERIALI DURI E RESISTENTI

Ref. BC73

HSSCo
8%



OX

HARDOX
450

BC73

	D1 mm	L1 mm	L2 mm	CM	€
BC731000	10,00	175	76	2	58,87
BC731020	10,20	175	76	2	58,87
BC731100	11,00	175	76	2	58,87
BC731200	12,00	179	81	2	64,49
BC731250	12,50	179	81	2	64,49
BC731300	13,00	179	81	2	64,49
BC731400	14,00	184	86	2	68,64
BC731450	14,50	187	89	2	69,55
BC731500	15,00	187	89	2	69,99
BC731550	15,50	187	89	2	79,50
BC731600	16,00	187	89	2	83,29
BC731650	16,50	190	92	2	87,14
BC731700	17,00	190	92	2	88,78
BC731800	18,00	190	92	2	90,11
BC731850	18,50	213	95	3	100,44
BC731900	19,00	213	95	3	102,38
BC732000	20,00	213	95	3	108,85
BC732100	21,00	219	102	3	118,55
BC732200	22,00	222	105	3	136,29
BC732400	24,00	222	105	3	146,83
BC732500	25,00	225	108	3	173,98
BC732600	26,00	270	124	4	206,15
BC732700	27,00	270	124	4	213,41
BC732800	28,00	270	124	4	219,46
BC733000	30,00	270	124	4	234,52
BC733200	32,00	280	133	4	298,02
BC733500	35,00	292	136	4	372,38
BC733600	36,00	292	146	4	391,65
BC734000	40,00	298	152	4	478,67
BC734500	45,00	298	152	4	651,02
BC735000	50,00	356	152	5	764,81
BC735500	55,00	360	156	5	954,05
BC736000	60,00	360	156	5	1.164,35

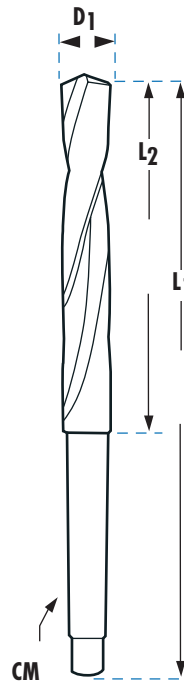

Punta speciale per HARDOX 450



Per praticare fori superiori a Ø25 mm si consiglia di realizzare un preforo di un terzo del diametro finale.
Esempio; se utilizzerà una punta di Ø30 mm, realizzi un preforo di Ø10 mm.

PUNTA CON CODOLO CONICO PER FORARE MATERIALI DURI E RESISTENTI

Ref. BC22...FT

DIN
345

HSSCo
5%

TiN



HARDOX
450

BC22...FT

	D1 mm	L1 mm	L2 mm	CM	€
BC221600FT	16,00	218	120	2	106,00
BC221800FT	18,00	228	130	2	115,31
BC222000FT	20,00	238	140	2	138,24
BC222200FT	22,00	248	150	2	163,58
BC222400FT	24,00	281	160	3	205,08
BC222500FT	25,00	281	160	3	214,86
BC222600FT	26,00	286	165	3	253,97
BC222800FT	28,00	291	170	3	312,30
BC223000FT	30,00	296	175	3	308,59
BC223200FT	32,00	334	185	4	349,18
BC223400FT	34,00	339	190	4	449,80
BC223600FT	36,00	344	195	4	507,80



- La migliore soluzione per eseguire fori di grande diametro in materiali ad alta durezza.
- Affilatura speciale di materiali molto duri, con taglio corretto e abbattimento del taglio laterale del bordo.



Punta speciale per HARDOX 450

Questa punta fu utilizzata storicamente per trapanare le rotaie delle ferrovie.

PUNTE ELICOIDALI CON CODOLO CONICO SERIE LUNGA
**DIN
341**

Ref. BC12



Ref. BC56



MATERIALE	BC12		BC56		BC12			BC56				
	HSS	HSSCo 5%	Ø mm	L1 x L2	CM	€	€	Ø mm	L1 x L2	CM	€	€
TIPO DI AFFILATURA			14,00	223x142	1	45,87	115,89	27,00	343x222	3	147,31	373,43
ANGOLO DI TAGLIO	118°	135°	14,25	245x147	2	77,01		27,50	343x222	3	197,75	
ELICA	30° "N"	38° "gr"	14,50	245x147	2	57,71		28,00	343x222	3	175,13	384,41
FINITURA	OX	OX	14,75	245x147	2	77,01		28,50	351x230	3	234,70	
APPLICAZIONE	70 Kg/mm²	120 Kg/mm²	15,00	245x147	2	57,71	134,57	29,00	351x230	3	191,79	417,39
			15,25	251x153	2	76,26		29,50	351x230	3	234,90	
			15,50	251x153	2	54,64	140,03	30,00	351x230	3	196,69	439,33
			15,75	251x153	2	79,08		30,50	360x239	3	268,58	
			16,00	251x153	2	58,74	140,03	31,00	360x239	3	248,42	494,25
			16,25	257x159	2	86,02		31,50	360x239	3	288,10	
			16,50	257x159	2	63,86	148,30	32,00	397x248	4	249,38	549,18
			16,75	257x159	2	86,02		32,50	397x248	4	315,73	
			17,00	257x159	2	63,86	148,30	33,00	397x248	4	265,75	
			17,25	263x165	2	84,19		33,50	397x248	4	311,73	
			17,50	263x165	2	67,86	156,52	34,00	406x257	4	323,48	
			17,75	263x165	2	95,71		34,50	406x257	4	342,51	
			18,00	263x165	2	71,06	167,51	35,00	406x257	4	325,43	
			18,25	269x171	2	96,09		35,50	406x257	4	342,51	
			18,50	269x171	2	77,13	174,35	36,00	416x267	4	374,45	
			18,75	269x171	2	99,19		36,50	416x267	4	473,87	
			19,00	269x171	2	74,98	174,35	37,00	416x267	4	403,32	
			19,25	275x177	2	104,09		37,50	416x267	4	469,60	
			19,50	275x177	2	84,28	181,75	38,00	426x277	4	422,25	
			19,75	275x177	2	105,36		38,50	426x277	4	535,26	
			20,00	275x177	2	80,40	181,75	39,00	426x277	4	438,68	
			20,25	282x184	2	97,50	211,43	39,50	426x277	4	535,26	
			20,50	282x184	2	92,25	211,43	40,00	426x277	4	474,46	
			21,00	289x191	2	111,28	230,65	41,00	436x287	4	606,66	
			21,50	289x191	2	105,01	230,65	42,00	436x287	4	632,76	
			22,00	296x198	2	114,75	244,38	43,00	447x298	4	673,42	
			22,50	296x198	2	100,87	263,62	44,00	447x298	4	683,68	
			23,00	319x198	3	133,60	271,84	45,00	447x298	4	720,58	
			23,50	319x198	3	134,87	296,56	46,00	459x310	4	758,20	
			24,00	327x206	3	143,23	307,54	47,00	459x310	4	797,97	
			24,50	327x206	3	129,44	288,33	48,00	470x321	4	834,09	
			25,00	335x214	3	162,61		49,00	470x321	4	861,35	
			25,50	335x214	3	142,16	340,49	50,00	470x321	4	891,76	
			26,00	335x214	3	167,74		55,00	505x310	5	1.166,05	

PUNTE ELICOIDALI CON CODOLO CONICO SERIE EXTRA LUNGA
**DIN
1870
I/II**

Ref. BC14



Ref. BC41



			BC14	BC41				BC14	BC41				BC14	BC41
MATERIALE			HSS	HSSCo 5%				€	€				€	€
TIPO DI AFFILATURA								€	€				€	€
ANGOLO DI TAGLIO								€	€				€	€
ELICA								€	€				€	€
FINITURA			OX	BRILLANTE				€	€				€	€
APPLICAZIONE								€	€				€	€
Ø mm	L1 x L2	CM	€	€	Ø mm	L1 x L2	CM	€	€	Ø mm	L1 x L2	CM	€	€
8,00	265x165	1	73,70		17,00	355x230	2	175,48	278,14	29,00	460x305	3	409,92	863,74
8,00	330x210	1	91,86		17,00	445x295	2	210,97	388,78	29,00	580x385	3	587,72	1.172,45
8,50	265x165	1	80,94		17,50	370x245	2	193,09	312,84	29,50	460x305	3	424,38	988,85
8,50	330x210	1	93,91		17,50	465x310	2	232,33	423,06	29,50	580x385	3	592,58	1.364,56
9,00	275x175	1	83,32		18,00	370x245	2	193,09	304,44	30,00	460x305	3	424,38	903,66
9,00	345x220	1	105,89		18,00	465x310	2	232,33	401,21	30,00	580x385	3	592,58	1.218,85
9,50	275x175	1	89,16		18,50	370x245	2	196,70	351,78	31,00	480x320	4	475,71	1.143,67
9,50	345x220	1	107,03		18,50	465x310	2	251,08	480,03	31,00	610x410	4	631,77	
10,00	285x185	1	91,59		19,00	370x245	2	198,84	350,96	32,00	505x320	4	497,39	
10,00	360x235	1	112,97		19,00	465x310	2	251,08	448,10	32,00	635x410	4	662,88	
10,50	285x185	1	90,35		19,50	385x260	2	221,21	392,49	33,00	505x320	4	542,01	
10,50	360x235	1	116,42		19,50	490x325	2	271,70	502,61	33,00	635x410	4	733,82	
11,00	300x195	1	101,55		20,00	385x260	2	215,73	385,61	34,00	530x340	4	587,69	
11,00	375x250	1	120,77		20,00	490x325	2	271,70	502,34	34,00	665x430	4	781,27	
11,50	300x195	1	111,20		20,50	385x260	2	253,17	513,25	35,00	530x340	4	605,31	
11,50	375x250	1	137,39		20,50	490x325	2	304,03	590,98	35,00	665x430	4	827,47	
12,00	310x205	1	113,80	232,94	21,00	385x260	2	243,05	471,39	36,00	530x340	4	653,03	
12,00	395x260	1	141,81		21,00	490x325	2	304,03	585,62	36,00	665x430	4	868,89	
12,50	310x205	1	121,11		21,50	405x270	2	269,99	555,18	37,00	530x340	4	669,55	
12,50	395x260	1	158,27		21,50	515x345	2	326,27	693,50	37,00	665x430	4	965,43	
13,00	310x205	1	121,11	244,12	22,00	405x270	2	259,19	503,43	38,00	555x360	4	730,36	
13,00	395x260	1	158,27		22,00	515x345	2	326,27	676,04	38,00	695x460	4	1.022,32	
13,50	325x220	1	132,59		22,50	405x270	2	307,67	590,98	39,00	555x360	4	761,20	
13,50	410x275	1	162,53		22,50	515x345	2	368,31	733,98	39,00	695x460	4	1.071,10	
14,00	325x220	1	131,21	233,01	23,00	405x270	2	295,36	576,36	40,00	555x360	4	774,35	
14,00	410x275	1	162,53	326,45	23,00	515x345	2	368,31	693,50	40,00	695x460	4	1.021,67	
14,50	340x220	2	145,25	254,90	23,50	425x270	3	338,05	722,26	41,00	555x360	4	928,19	
14,50	425x275	2	177,02	357,94	23,50	535x345	3	409,92	880,94	41,00	695x460	4	1.161,24	
15,00	340x220	2	145,25	244,86	24,00	440x290	3	338,05	659,53	42,00	555x360	4	958,78	
15,00	425x275	2	177,02	347,66	24,00	555x365	3	409,92	807,03	42,00	695x460	4	1.239,88	
15,50	355x230	2	162,82	284,77	24,50	440x290	3	350,33	779,25	43,00	585x385	4	999,83	
15,50	445x295	2	195,25	383,70	24,50	555x365	3	431,99	926,22	43,00	735x490	4	1.265,11	
16,00	355x230	2	162,82	270,45	25,00	440x290	3	350,33	695,02	44,00	585x385	4	1.062,11	
16,00	445x295	2	195,25	373,95	25,00	555x365	3	431,99	828,40	44,00	735x490	4	1.309,56	
16,50	355x230	2	162,61	284,77	25,50	440x290	3	362,10	829,20	45,00	585x385	4	1.078,51	
16,50	445x295	2	210,97	388,09	25,50	555x365	3	477,21	1.079,83	45,00	735x490	4	1.370,57	
					26,00	440x290	3	362,10	751,46	46,00	585x385	4	1.111,50	
					26,00	555x365	3	477,21	971,65	46,00	735x490	4	1.431,82	
					26,50	440x290	3	370,81	842,00	47,00	585x385	4	1.100,32	
					26,50	555x365	3	492,37	1.159,35	47,00	735x490	4	1.502,13	
					27,00	460x305	3	370,81	781,04	48,00	605x405	4	1.162,45	
					27,00	580x385	3	492,37	1.028,49	48,00	765x510	4	1.589,50	
					27,50	460x305	3	395,56	916,05	49,00	605x405	4	1.241,28	
					27,50	580x385	3	532,63	1.227,64	49,00	765x510	4	1.650,01	
					28,00	460x305	3	395,56	827,41	50,00	605x405	4	1.226,71	
					28,00	580x385	3	532,63	1.117,67	50,00	765x510	4	1.693,12	
					28,50	460x305	3	409,92	971,93					
					28,50	580x385	3	587,72	1.278,55					

PUNTA CON CODOLO CONICO HSS CON REFRIGERAZIONE INTERNA

Ref. BC87

 $\leq 10xD$
**DIN
341**
HSS

OX

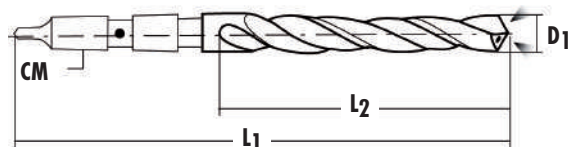
**AFFILATURA SPECIALE 170°
CON PUNTA PILOTA
CENTRATURA PRECISA**

BC87					
	D1 mm	L1 mm	L2 mm	CM	€
BC871000	10,0	268	116	3	438,98
BC871050	10,5	268	116	3	445,00
BC871100	11,0	278	125	3	445,00
BC871200	12,0	287	134	3	454,75
BC871300	13,0	287	134	3	454,75
BC871350	13,5	285	142	3	454,75
BC871400	14,0	285	142	3	454,75
BC871450	14,5	245	147	2	470,25*
BC871500	15,0	300	147	3	470,25
BC871550	15,5	251	153	2	486,05*
BC871600	16,0	306	153	3	486,05
BC871650	16,5	257	159	2	486,05*
BC871700	17,0	311	159	3	486,05
BC871750	17,5	318	165	3	517,02
BC871800	18,0	318	165	3	517,02
BC871900	19,0	324	171	3	532,91
BC872000	20,0	330	177	3	544,43
BC872100	21,0	343	184	3	571,90
BC872200	22,0	350	191	3	633,04

BC87					
	D1 mm	L1 mm	L2 mm	CM	€
BC872300	23,0	357	198	3	626,98
BC872400	24,0	365	206	3	626,98
BC872500	25,0	365	206	3	639,96
BC872600	26,0	373	214	3	705,57
BC872700	27,0	375	222	4	736,85
BC872800	28,0	375	222	4	808,69
BC872900	29,0	375	230	4	862,46
BC873000	30,0	375	230	4	889,57
BC873100	31,0	375	239	4	1.097,36
BC873200	32,0	375	248	4	1.097,36
BC873300	33,0	375	248	4	1.282,23
BC873400	34,0	375	257	4	1.282,23
BC873500	35,0	375	257	4	1.442,01
BC873600	36,0	375	257	4	1.442,01
BC873700	37,0	375	257	4	1.630,13
BC873800	38,0	375	277	4	1.630,13
BC873900	39,0	375	277	4	1.818,41
BC874000	40,0	375	277	4	1.818,41

*Fino ad esaurimento scorte.

PUNTE IN SCATOLE DI METALLO E PLASTICA



Ref. PT6010

Plástica Blu

- Rigido, robusto e leggero
- Finestra trasparente
- Plastica rinforzata con gomma antiurto

P I riferimenti che iniziano con "P" vengono forniti in custodia plastica.

Ref. P6011



Ref. PP6010

Metallo "Classico"

- Scatola metallica alta resistenza

M



Ref. DC011



Ref. DC010

Ref. BC2



Ref. BC02



BC2		Ref.	Unità	CONTENUTO	€
DIN 338	HSS	D0010	19 M	Ø 1-10 x 0,50 mm	65,47
		D0011	25 M	Ø 1-13 x 0,50 mm	136,22
		P6010	19 P	Ø 1-10 x 0,50 mm	65,47
		P6011	25 P	Ø 1-13 x 0,50 mm	136,22
Quarti		AD001	37 M	Ø 1-10 x 0,25 mm	178,38
		AD002	49 M	Ø 1-13 x 0,25 mm	320,14
Decimi		D0014	50 M	Ø 1-5,90 x 0,10 mm	125,09
		D0015	41 M	Ø 6-10 x 0,10 mm	325,11
		D0022	81 M	Ø 2-10 x 0,10 mm	557,56
Medi + Prefori		D0017	23 M	Ø 1-10 x 0,50 + Ø prefori*	124,81
		D0035	29 M	Ø 1-13 x 0,50 + Ø prefori*	206,28
Composizioni Aggiuntive		D0007	10 M	Ø 1-10 x 1 mm	53,28
		D0009	13 M	Ø 1,5-6,5x0,5 (+3,2 & 4,8) mm	25,30
		D0008	13 M	Ø 1-7 x 0,50 mm	26,32
		D0006	12 M	Ø 2-7 x 0,50 + 8 mm	48,31

BC02		Ref.	Unità	CONTENUTO	€
DIN 338	Plus	DP010	19 M	Ø 1-10 x 0,50 mm	74,02
		DP011	25 M	Ø 1-13 x 0,50 mm	153,13
		PP6010	19 P	Ø 1-10 x 0,50 mm	74,02
		PP6011	25 P	Ø 1-13 x 0,50 mm	153,13
Quarti		ADP01	37 M	Ø 1-10 x 0,25 mm	213,65
		ADP02	49 M	Ø 1-13 x 0,25 mm	380,18
Decimi		Su richiesta	50 M	Ø 1-5,90 x 0,10 mm	
		Su richiesta	41 M	Ø 6-10 x 0,10 mm	
		Su richiesta	81 M	Ø 2-10 x 0,10 mm	
Medi + Prefori		DP017	23 M	Ø 1-10 x 0,50 + Ø prefori*	124,91
		DP035	29 M	Ø 1-13 x 0,50 + Ø prefori*	214,92
Composizioni Aggiuntive		DP007	10 M	Ø 1-10 x 1 mm	69,89
		DP009	13 M	Ø 1,5-6,5x0,5 (+3,2 & 4,8) mm	29,72
		DP008	13 M	Ø 1-7 x 0,50 mm	29,73
		DP006	12 M	Ø 2-7 x 0,50 + 8 mm	50,00

Ref. BC5



Ref. BC18



BC5		Ref.	Unità	CONTENUTO	€
DIN 338	HSSCo 5%	DC010	19 M	Ø 1-10 x 0,50 mm	109,41
		DC011	25 M	Ø 1-13 x 0,50 mm	237,33
		PC6010	19 P	Ø 1-10 x 0,50 mm	109,41
		PC6011	25 P	Ø 1-13 x 0,50 mm	237,33
Quarti		ADC01	37 M	Ø 1-10 x 0,25 mm	257,95
		ADC02	49 M	Ø 1-13 x 0,25 mm	577,34
Decimi		DC014	50 M	Ø 1-5,90 x 0,10 mm	187,93
		DC015	41 M	Ø 6-10 x 0,10 mm	482,42
		DC022	81 M	Ø 2-10 x 0,10 mm	762,56
Medi + Prefori		DC017	23 M	Ø 1-10 x 0,50 + Ø prefori*	175,16
		DC035	29 M	Ø 1-13 x 0,50 + Ø prefori*	335,54
Composizioni Aggiuntive		DC007	10 M	Ø 1-10 x 1 mm	91,04
		DC009	13 M	Ø 1,5-6,5x0,5 (+3,2 & 4,8) mm	44,34
		DC008	13 M	Ø 1-7 x 0,50 mm	46,46
		DC006	12 M	Ø 2-7 x 0,50 + 8 mm	69,64

BC18		Ref.	Unità	CONTENUTO	€
HSS	TiN	DT010	19 M	Ø 1-10 x 0,50 mm	91,96
		DT011	25 M	Ø 1-13 x 0,50 mm	193,57
		PT6010	19 P	Ø 1-10 x 0,50 mm	91,96
		PT6011	25 P	Ø 1-13 x 0,50 mm	193,57
Quarti		ADT01	37 M	Ø 1-10 x 0,25 mm	213,00
		ADT02	49 M	Ø 1-13 x 0,25 mm	427,18
Decimi		Su richiesta	50 M	Ø 1-5,90 x 0,10 mm	
		Su richiesta	41 M	Ø 6-10 x 0,10 mm	
		Su richiesta	81 M	Ø 2-10 x 0,10 mm	
Medi + Prefori			23 M	Ø 1-10 x 0,50 + Ø prefori*	
			29 M	Ø 1-13 x 0,50 + Ø prefori*	
Composizioni Aggiuntive		DT007	10 M	Ø 1-10 x 1 mm	72,56
		DT009	13 M	Ø 1,5-6,5x0,5 (+3,2 & 4,8) mm	36,57
		DT008	13 M	Ø 1-7 x 0,50 mm	39,69
		DT006	12 M	Ø 2-7 x 0,50 + 8 mm	59,39

* Prefori: da M3 a M12 (Ø3,30 - Ø4,20 - Ø6,80 - Ø10,20)

PUNTE IN SCATOLE DI METALLO E PLASTICA

Punte Metallo

Grigio

Rosa

Metallo "Classico"

- Scatola metallica alta resistenza

M
Plástica Blu

- Rigido, robusto e leggero
- Finestra trasparente
- Plastica rinforzata con gomma antiurto

P I riferimenti che iniziano con "P" vengono forniti in custodia plastica.

Ref. PTTX011

Ref. BC95



Ref. BC58



BC95		Ref.	Unità		CONTENUTO	€
HSSCo 5%		DC9510	19	M	Ø 1-10 x 0,50 mm	122,14
		DC9511	25	M	Ø 1-13 x 0,50 mm	276,08
		PC9510	19	P	Ø 1-10 x 0,50 mm	122,14
		PC9511	25	P	Ø 1-13 x 0,50 mm	276,08

BC58		Ref.	Unità		CONTENUTO	€
DIN 338	HSSCo 8%	DC810	19	M	Ø 1-10 x 0,50 mm	158,30
		DC811	25	M	Ø 1-13 x 0,50 mm	373,48
		Quarti				
		ADC81	37	M	Ø 1-10 x 0,25 mm	364,82
		ADC82	49	M	Ø 1-13 x 0,25 mm	856,03

Ref. BC82



BC82		Ref.	Uds.		CONTENUTO	€
DIN 338	HSS	D8210	19	M	Ø 1-10 x 0,50 mm	65,47
		D8211	25	M	Ø 1-13 x 0,50 mm	136,22

Medi + Prefori		DC817	23	M	Ø 1-10 x 0,50 + Ø prefori*	234,92
		DC835	29	M	Ø 1-10 x 0,50 + Ø prefori*	454,71
Composizioni Aggiuntive		DC806	12	M	Ø 2-7 x 0,50 + 8 mm	91,75
		DC807	10	M	Ø 1-10 x 1 mm	115,30

Ref. BTX



BTX		Ref.	Unità		CONTENUTO	€
Ø ≥ 3	HSSCo 5%	PTX010	19	P	Ø 1-10 x 0,50 mm	123,38
		PTX011	25	P	Ø 1-13 x 0,50 mm	294,77

Ref. TTX



TTX		Ref.	Unità		CONTENUTO	€
Ø ≥ 3	HSS	PTTX010	19	P	Ø 1-10 x 0,50 mm	111,05
		PTTX011	25	P	Ø 1-13 x 0,50 mm	265,28
	TiAlSiN					

Ref. TK02



TK02		Ref.	Unità		CONTENUTO	€
DIN 338	HSS	TK02010	19	P	Ø 1-10 x 0,50 mm	198,38
Ø ≥ 4		TK02011	25	P	Ø 1-13 x 0,50 mm	353,91

Ref. TK05



TK05		Ref.	Unità		CONTENUTO	€
DIN 338	HSSCo 5%	TK05010	19	P	Ø 1-10 x 0,50 mm	247,97
Ø ≥ 5		TK05011	25	P	Ø 1-13 x 0,50 mm	442,39

PUNTE IN SCATOLE METALLICHE (Composizioni speciali)

PUNTE HSS PER ALLUMINIO

Ref. BC16



BC16		Ref.	Unità	CONTENUTO	€
DIN 338	HSS	D16010	19 M	Ø 1-10 x 0,50 mm	101,51
		D16011	25 M	Ø 1-13 x 0,50 mm	222,69

PUNTE HSSCo CON GEOMETRIA TIPO "S"

Ref. BC55



BC55		Ref.	Unità	CONTENUTO	€
DIN 338	HSSCo 5%	D55010	18 M	Ø 1,50-10 x 0,50 mm	198,41
		D55011	24 M	Ø 1,50-13 x 0,50 mm	402,09

PUNTE CON PUNTA IN METALLO DURO PER ACCIAI TRATTATI, GHISE, ECC.

Ref. BC7



BC7		Ref.	Unità	CONTENUTO	€
DIN 338	PMD	DPMD010	17 M	Ø 2-10 x 0,50 mm	379,47
		DPMD011	23 M	Ø 2-13 x 0,50 mm	665,42

PUNTE IN METALLO DURO INTEGRALE PER MATERIALI MOLTO DURI

Ref. BC42



BC42		Ref.	Unità	CONTENUTO	€
DIN 338	MD	D42010	17 M	Ø 2-10 x 0,50 mm	1.067,29
		D42011	23 M	Ø 2-13 x 0,50 mm	2.392,00

PUNTE SPECIALI PER ACCIAIO INOX

Ref. BC50



BC50		Ref.	Unità	CONTENUTO	€
DIN 338	HSSCo 5%	D50010	19 M	Ø 1-10 x 0,50 mm	315,51
		D50011	25 M	Ø 1-13 x 0,50 mm	476,81

PUNTE CON TAGLIO A SINISTRA



Ref. BC15



BC15		Ref.	Unità	CONTENUTO	€
DIN 338	HSS	D0010I	19 M	Ø 1-10 x 0,50 mm	162,17
		D0011I	25 M	Ø 1-13 x 0,50 mm	325,77
		DR9312I	10 P	Ø 1-10 x 1 mm	79,33

SCATOLE VUOTE

Ref.	Unità	CONTENUTO	€
D0010V	19 M	Ø 1-10 x 0,50 mm	20,30
D0011V	25 M	Ø 1-13 x 0,50 mm	28,30
AD001V	37 M	Ø 1-10 x 0,25 mm	74,38
AD002V	49 M	Ø 1-13 x 0,25 mm	86,39
D0014V	50 M	Ø 1-5,9 x 0,10 mm	65,87
D0015V	41 M	Ø 6-10 x 0,10 mm	131,62
D0022V	81 M	Ø 2-10 x 0,10 mm	252,45
D0006V	12 M	Ø 2-7 x 0,50 + 8 mm	27,53
D0007V	10 M	Ø 1-10 x 1 mm	47,26
D0017V	23 M	Ø 1-10 x 0,50 mm + prefori*	54,80
D0035V	29 M	Ø 1-13 x 0,50 mm + prefori*	76,30
DE10V	19 M	Ø 1-10 x 0,50 mm	46,94
DE11V	25 M	Ø 1-13 x 0,50 mm	57,65

DIN 1897



* Prefori: da M3 a M12 (Ø3,30 - Ø4,20 - Ø6,80 - Ø10,20)

PUNTE IN SCATOLE DI METALLO
PUNTE SERIE LUNGA DIN 340

Ref. BC4



BC4		Ref.	Unità	CONTENUTO	€	
DIN 340	HSS	D0004	19	M	Ø 1-10 x 0,50 mm	104,92

Ref. BC47



BC47		Ref.	Unità	CONTENUTO	€	
DIN 340	HSSCo 5%	DC004	x17	M	Ø 2-10 x 0,50 mm	225,24

Ref. BC40



BC40		Ref.	Unità	CONTENUTO	€	
HSS	TiN	DT004	19	M	Ø 1-10 x 0,50 mm	163,06

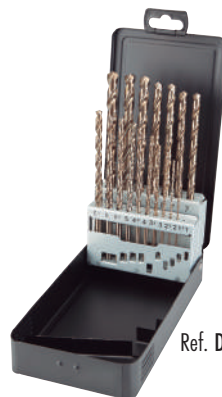

Ref. DC004



Ref. DT004

PUNTE SERIE EXTRACORTA DIN 1897

Ref. BC3



BC3		Ref.	Unità	CONTENUTO	€	
DIN 1897	HSS	D3010	19	M	Ø 1-10 x 0,50 mm	74,48
		D3011	25	M	Ø 1-13 x 0,50 mm	119,66

Ref. BC31



BC31		Ref.	Unità	CONTENUTO	€	
DIN 1897	HSSCo 5%	D3110	19	M	Ø 1-10 x 0,50 mm	107,56
		D3111	25	M	Ø 1-13 x 0,50 mm	225,14

Ref. BC33



BC33		Ref.	Unità	CONTENUTO	€	
DIN 1897	HSSCo 5%	D3310	19	M	Ø 1-10 x 0,50 mm	161,34
		D3311	25	M	Ø 1-13 x 0,50 mm	270,07

Ref. BC77



BC77		Ref.	Unità	CONTENUTO	€	
DIN 1897	PMD	D7710	17	M	Ø 2-10 x 0,50 mm	402,60
		D7711	23	M	Ø 2-13 x 0,50 mm	634,84

Ref. BC43



BC43		Ref.	Unità	CONTENUTO	€	
DIN 1897	MD	D4310	17	M	Ø 2-10 x 0,50 mm	691,77
		D4311	23	M	Ø 2-13 x 0,50 mm	1.457,10



Ref. D7710



Ref. D3110

PUNTE IN SCATOLE DI PLASTICA



Ref. DP9314



Ref. DP9312



Ref. DP9313



Ref. DP9311

Ref. BC2



BC2		Ref.	Unità	CONTENUTO	€
DIN 338	HSS	DR9314	6	Ø 2 - 3 - 4 - 5 - 6 - 8 mm	19,04
		DR9312	10	Ø 1-10 x 1 mm	40,56
		DR9313	13	Ø 2-8 x 0,50 mm	40,25
		DR9311	19	Ø 1-10 x 0,50 mm	70,87

Ref. BC02



BC02		Ref.	Unità	CONTENUTO	€
DIN 338	Plus	DP9314	6	Ø 2 - 3 - 4 - 5 - 6 - 8 mm	20,09
		DP9312	10	Ø 1-10 x 1 mm	43,89
		DP9313	13	Ø 2-8 x 0,50 mm	42,92
		DP9311	19	Ø 1-10 x 0,50 mm	77,39

Ref. BC5



BC5		Ref.	Unità	CONTENUTO	€
DIN 338	HSSCo 5%	DC9314	6	Ø 2 - 3 - 4 - 5 - 6 - 8 mm	30,27
		DC9312	10	Ø 1-10 x 1 mm	64,95
		DC9313	13	Ø 2-8 x 0,50 mm	65,43
		DC9311	19	Ø 1-10 x 0,50 mm	116,09

Ref. BC18



BC18		Ref.	Unità	CONTENUTO	€
HSS	TiN	DT9314	6	Ø 2 - 3 - 4 - 5 - 6 - 8 mm	19,79
		DT9312	10	Ø 1-10 x 1 mm	42,03
		DT9313	13	Ø 2-8 x 0,50 mm	40,61
		DT9311	19	Ø 1-10 x 0,50 mm	73,34

Ref. BC82



BC82		Ref.	Unità	CONTENUTO	€
DIN 338	HSS	D829314	6	Ø 2 - 3 - 4 - 5 - 6 - 8 mm	18,04
		D829312	10	Ø 1-10 x 1 mm	38,39
		D829313	13	Ø 2-8 x 0,50 mm	38,10
		D829311	19	Ø 1-10 x 0,50 mm	67,08

Ref. BC58



BC58		Ref.	Unità	CONTENUTO	€
DIN 338	HSSCo 8%	D89314	6	Ø 2 - 3 - 4 - 5 - 6 - 8 mm	38,64
		D89312	10	Ø 1-10 x 1 mm	82,64
		D89313	13	Ø 2-8 x 0,50 mm	84,70
		D89311	19	Ø 1-10 x 0,50 mm	148,59

				Ref.	Unità	CONTENUTO	€
BC95	HSSCo 5%	OX DORATO		DC959314	6	Ø 2-3-4-5-6-8 mm	31,26
BTX	Ø ≥ 3	HSSCo 5%		PTX9314	6	Ø 2-3-4-5-6-8 mm	30,07
TTX	Ø ≥ 3	HSS		PTTX9314	6	Ø 2-3-4-5-6-8 mm	27,97
TK02	DIN 338	HSS		PTK029314	6	Ø 2-3-4-5-6-8 mm	48,83
TK05	DIN 338	HSSCo 5%		PTK059314	6	Ø 2-3-4-5-6-8 mm	61,04

Ref. BC95



Ref. BTX



Ref. TTX



Ref. TK02



Ref. TK05



PUNTE IN SCATOLE DI PLASTICA
BARATTOLI CLASSIFICATORI DI PLASTICA DA 19 PEZZI

					Ref.	Unità	CONTENUTO	€
BC2	DIN 338	HSS	118°		DR9380	19	Ø 1-10 x 0,50 mm	66,46
BC02	DIN 338	Plus	118°		DP9380	19	Ø 1-10 x 0,50 mm	74,42
BC5	DIN 338	HSSCo 5%	135°		DC9380	19	Ø 1-10 x 0,50 mm	110,81
BC18	TiN	HSS	118°		DT9380	19	Ø 1-10 x 0,50 mm	93,77
BC58	DIN 338	HSSCo 8%	135°		D89380	19	Ø 1-10 x 0,50 mm	150,70

Ref. BC2



Ref. BC02



Ref. BC5



Ref. BC18

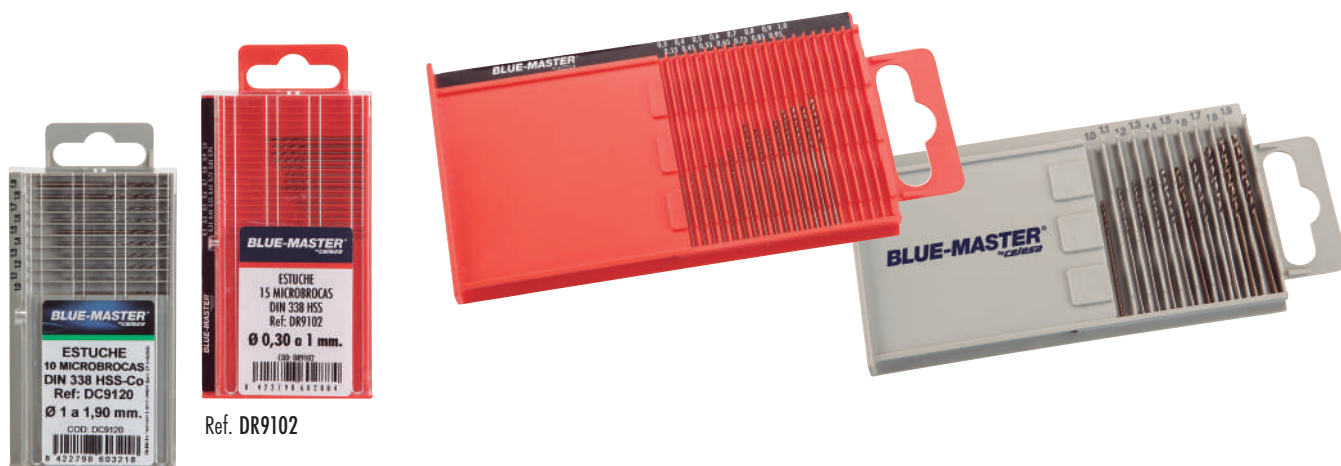

Ref. BC58

SET DI MICROPUNTE RETTIFICATE IN SCATOLE DI PLASTICA, AEROMODELLISMO E INTARSIO

Ref. DR9102

Ref. DC9120

			Ref.	Unità	CONTENUTO	€
DR9120	DIN 338	HSS	DR9120	10	Ø 1-1,90 x 0,10 mm	25,55
DC9120	DIN 338	HSSCo 5%	DC9120	10	Ø 1-1,90 x 0,10 mm	36,40
DR9102	DIN 338	HSS	DR9102	15	Ø 0,30 - 0,35 - 0,40 - 0,45 - 0,50 - 0,55 - 0,60 - 0,65 - 0,70 - 0,75 - 0,80 - 0,85 - 0,90 - 0,95 - 1	49,30

ASTUCCI DI PLASTICA MISTI: HSS, WIDIA E LEGNO

SERIE STANDARD

HSS				
	(Ref. BC2)			
PMD				
	(Ref. BW1)			
CV				
	(Ref. BM)			

REFERENZA	EC9330	EC9331	EC9332
N° PUNTE	8	9	9
QUALITÀ	 	  	  
CONTENUTO	Ø 4 - 5 - 6 - 8 mm x 2	Ø 4 - 6 - 8 mm x 3	Ø 5 - 6 - 8 mm x 3
P.V.P. €	22,04	25,12	25,61

*Fino ad esaurimento scorte.

SERIE PROFESSIONALE

HSSCo 5%				
	(Ref. BC5)			
PMD				
	(Ref. BW6)			
HSS				
	(Ref. Bmpr)			

REFERENZA	M9330	M9331	M9332	M9382
N° PUNTE	8	9	9	18
QUALITÀ	 	  	  	  
CONTENUTO	Ø 4 - 5 - 6 - 8 mm x 2	Ø 4 - 6 - 8 mm x 3	Ø 5 - 6 - 8 mm x 3	Ø 3 - 4 - 5 - 6 - 8 - 10 mm x 3
P.V.P. €	36,72	37,04	38,29	73,79*

*Fino ad esaurimento scorte.

SERIE EXTRA PROFESSIONALE

HSSCo 5%				
	(Ref. BC5)			
PMD				
	(Ref. BW15)			
HSS				
	(Ref. Bmpr)			

REFERENZA	P9330	P9331	P9332	P9382
N° PUNTE	8	9	9	18
QUALITÀ	 	  	  	  
CONTENUTO	Ø 4 - 5 - 6 - 8 mm x 2	Ø 4 - 6 - 8 mm x 3	Ø 5 - 6 - 8 mm x 3	Ø 3 - 4 - 5 - 6 - 8 - 10 mm x 3
P.V.P. €	60,46*	56,36*	56,55*	114,71*

*Fino ad esaurimento scorte.

ARMADI ESPOSITORI PER LA PRESENTAZIONE DI PUNTE CILINDRICHI DIN 338

Punte Metallo

Grigio

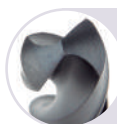
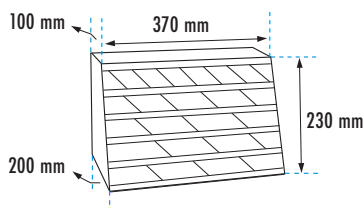

Ref. BC2

DIN 338

HSS



118°



30° "N"



OX



70 Kg/mm²



HSS

CONTENUTO 400 PUNTE

Punte BC2

1,00	1,50	2,00	2,50	3,00	3,50	4,00	4,50	5,00	5,50	6,00	6,50	7,00
10	10	20	20	50	30	40	20	40	10	30	10	10
7,50	8,00	8,50	9,00	9,50	10,00	10,50	11,00	11,50	12,00	12,50	13,00	
10	20	10	10	10	10	5	5	5	5	5	5	



EXPBROCASBC2

1.295,80 €



Ref. BC02

DIN 338

HSS-G Plus



118°



30° "N"



OX DORATO



70 Kg/mm²



HSS-G Plus



CONTENUTO 316 PUNTE

Punte BC02

1,00	1,50	2,00	2,50	3,00	3,50	4,00	4,50	5,00	5,50	6,00	6,50	7,00
10	10	20	10	20	10	30	10	30	10	30	10	10
7,50	8,00	8,50	9,00	9,50	10,00	10,50	11,00	11,50	12,00	12,50	13,00	
10	20	10	10	10	10	6	6	6	6	6	6	

EXPBROCASBC02

1.390,74 €

ARMADI ESPOSITORI PER LA PRESENTAZIONE DI PUNTE CILINDRICHI DIN 338



EXPBROCASBC5
1.801,30 €



Ref. BC5

DIN 338

HSSCo 5%



135°



30° "N"



DORATO

120 Kg/mm²



HSSCo 5%



CONTENUTO 220 PUNTE

Punte BC5

1,00 10	1,50 10	2,00 10	2,50 10	3,00 10	3,50 10	4,00 10	4,50 10	5,00 10	5,50 10	6,00 10	6,50 10	7,00 10
7,50 10	8,00 10	8,50 10	9,00 10	9,50 10	10,00 10	10,50 5	11,00 5	11,50 5	12,00 5	12,50 5	13,00 5	



Ref. BC18

DIN 338

HSS



118°



30° "N"



TiN



PRODUZIONE



HSS

TiN



CONTENUTO 200 PUNTE

Punte BC18

1,00 10	1,50 10	2,00 10	2,50 10	3,00 10	3,50 10	4,00 10	4,50 10	5,00 10	5,50 10	6,00 10	6,50 10	7,00 10
7,50 10	8,00 10	8,50 5	9,00 5	9,50 5	10,00 5	10,50 5	11,00 5	11,50 5	12,00 5	12,50 5	13,00 5	



EXPBROCASBC18
1.230,60 €



EXPBROCASBC95
1.128,09 €



Ref. BC95

DIN 338

HSSCo 5%



130°



Ø ≥ 3

OX DORATO

INOX



HSSCo 5%



CONTENUTO 176 PUNTE

Punte BC95

1,00 10	1,50 10	2,00 10	2,50 10	3,00 10	3,50 10	4,00 10	4,50 10	5,00 10	5,50 10	6,00 10	6,50 10	7,00 10
7,50 10	8,00 10	8,50 5	9,00 5	9,50 5	10,00 5	10,50 1	11,00 1	11,50 1	12,00 1	12,50 1	13,00 1	

ARMADI ESPOSITORI PER LA PRESENTAZIONE DI PUNTE CILINDRICHI DIN 338

Ref. BTX

**DIN
338**
**HSSCo
5%**

DORATO

**HSSCo
5%**

CONTENUTO 176 PUNTE

Punte BC5 (Ø1-2,5mm) Punte (BTX Ø3-13mm)

<u>1,00</u> 10	<u>1,50</u> 10	<u>2,00</u> 10	<u>2,50</u> 10	<u>3,00</u> 10	<u>3,50</u> 10	<u>4,00</u> 10	<u>4,50</u> 10	<u>5,00</u> 10	<u>5,50</u> 10	<u>6,00</u> 10	<u>6,50</u> 10	<u>7,00</u> 10
<u>7,50</u> 10	<u>8,00</u> 10	<u>8,50</u> 5	<u>9,00</u> 5	<u>9,50</u> 5	<u>10,00</u> 5	<u>10,50</u> 1	<u>11,00</u> 1	<u>11,50</u> 1	<u>12,00</u> 1	<u>12,50</u> 1	<u>13,00</u> 1	

EXPBROCASBTX

96,20 €

EXPBROCASBTX

1.031,06 €

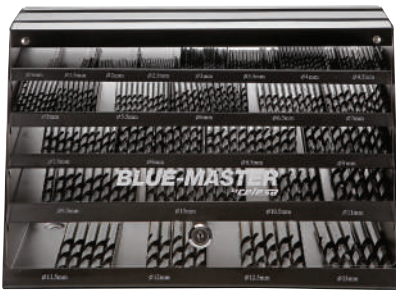

Ref. TK02

**DIN
338**
HSS

AI

Cu-Ni-Zn

PVC

STEP CUT

HSS

CONTENUTO 176 PUNTE

Punte TK02

<u>1,00</u> 10	<u>1,50</u> 10	<u>2,00</u> 10	<u>2,50</u> 10	<u>3,00</u> 10	<u>3,50</u> 10	<u>4,00</u> 10	<u>4,50</u> 10	<u>5,00</u> 10	<u>5,50</u> 10	<u>6,00</u> 10	<u>6,50</u> 10	<u>7,00</u> 10
<u>7,50</u> 10	<u>8,00</u> 10	<u>8,50</u> 5	<u>9,00</u> 5	<u>9,50</u> 5	<u>10,00</u> 5	<u>10,50</u> 1	<u>11,00</u> 1	<u>11,50</u> 1	<u>12,00</u> 1	<u>12,50</u> 1	<u>13,00</u> 1	

EXPBROCASTK02

1.724,78 €



Ref. TK05

**DIN
338**
**HSSCo
5%**

INOX

GHISA

Cu-Ni-Zn

PVC

STEP CUT

**HSSCo
5%**

CONTENUTO 176 PUNTE

Punte TK05

<u>1,00</u> 10	<u>1,50</u> 10	<u>2,00</u> 10	<u>2,50</u> 10	<u>3,00</u> 10	<u>3,50</u> 10	<u>4,00</u> 10	<u>4,50</u> 10	<u>5,00</u> 10	<u>5,50</u> 10	<u>6,00</u> 10	<u>6,50</u> 10	<u>7,00</u> 10
<u>7,50</u> 10	<u>8,00</u> 10	<u>8,50</u> 5	<u>9,00</u> 5	<u>9,50</u> 5	<u>10,00</u> 5	<u>10,50</u> 1	<u>11,00</u> 1	<u>11,50</u> 1	<u>12,00</u> 1	<u>12,50</u> 1	<u>13,00</u> 1	



EXPBROCASTK05

2.181,38 €

VALIGIE METALLICHE DI PUNTE RETTIFICATE



DIN 338

125 PUNTE Ø 1-10 mm x 0,50

Ø	1	1,50	2	2,50	3	3,50	4	4,50
Q.tà	10	5	10	5	10	5	10	5
	5	5,50	6	6,50	7	7,50	8	8,50
	10	5	10	5	5	5	5	5
	9	9,50	10	= 125 Punte				
	5	5	5					



REFERENZA	BC2880	BC02880	BC5880	BC18880	M0880V
N° PUNTE	125	125	125	125	250
QUALITÀ	HSS	Plus	HSSCo 5%	HSS TiN	
CONTENUTO	Ø 1-10 x 0,50 S/DETTAGLIATO	Ø 1-10 x 0,50 S/DETTAGLIATO	Ø 1-10 x 0,50 S/DETTAGLIATO	Ø 1-10 x 0,50 S/DETTAGLIATO	ASTUCCIO VUOTO
P.V.P. €	417,31	467,19	690,77	563,93	161,79



DIN 338

155 Punte Ø 1-13 mm x 0,50

Ø	1	1,50	2	2,50	3	3,50	4	4,50	5
Q.tà	10	5	10	5	10	5	10	5	10
	5,50	6	6,50	7	7,50	8	8,50	9	9,50
	5	10	5	5	5	5	5	5	5
	10	10,50	11	11,50	12	12,50	13	=155 Punte	
	5	5	5	5	5	5	5		



REFERENZA	BC2881	BC02881	BC5881	BC18881	M0881V
N° PUNTE	155	155	155	155	290
QUALITÀ	HSS	Plus	HSSCo 5%	HSS TiN	
CONTENUTO	Ø 1-13 x 0,50 S/DETTAGLIATO	Ø 1-13 x 0,50 S/DETTAGLIATO	Ø 1-13 x 0,50 S/DETTAGLIATO	Ø 1-13 x 0,50 S/DETTAGLIATO	ASTUCCIO VUOTO
P.V.P. €	838,20	931,03	1.487,45	1.071,92	374,64

VALIGETTE METALLICHE DI PUNTE CONICHE DIN 345

DIN 345

HSS



(Punte Ref. BC11)

REFERENZA	MBC11-1	MBC11-2
N° PUNTE	10	10
QUALITÀ	HSS	HSS
CONTENUTO	Ø 14 - 15 - 16 - 17 - 18 - 19 - 20 - 21 - 22 - 23	Ø 14 - 16 - 18 - 20 - 22 - 24 - 25 - 26 - 28 - 30
P.V.P. €	701,15	976,02

TABELLA DI CONSULTAZIONE DEI PARAMETRI DI TAGLIO E AVANZAMENTO PER PUNTE

			DIAMETRO Ø (mm)											
			2	3	5	7	10	12	15	18	20	22	25	30
ACCIAIO DOLCE 70 kg/mm ² BC2	V/C 25 m/min	RPM	3979	2653	1592	1137	796	663	531	442	398	362	318	265
		mm / giro	0,04	0,06	0,08	0,15	0,20	0,26	0,30	0,33	0,34	0,35	0,35	0,39
		S (mm / min)	159	159	127	171	159	172	159	146	135	127	111	103
ACCIAIO TRATTATO 120 kg/mm ² BC5	V/C 13 m/min	RPM	2069	1379	828	591	414	345	276	230	207	188	166	138
		mm / giro	0,03	0,045	0,06	0,10	0,15	0,18	0,20	0,22	0,23	0,25	0,25	0,28
		S (mm / min)	62	62	50	59	62	60	55	51	48	47	41	39
INOX BC50	V/C 11 m/min	RPM	1751	1167	700	500	350	292	233	195	175	159	140	117
		mm / giro	0,02	0,05	0,08	0,14	0,19	0,23	0,25	0,27	0,28	0,30	0,31	0,33
		S (mm / min)	35	58	56	70	67	67	58	53	49	48	43	39
ALLUMINIO BC16	V/C 50 m/min	RPM	7958	5305	3183	2274	1592	1326	1061	884	796	723	637	531
		mm / giro	0,03	0,06	0,08	0,16	0,20	0,23	0,25	0,28	0,29	0,30	0,30	0,36
		S (mm / min)	239	318	255	364	318	305	265	248	231	217	191	191
TITANIO BC42	V/C 18 m/min	RPM	5570	3714	2228	1592	1114	928	743	619	557	506	446	371
		mm / giro	0,02	0,03	0,03	0,05	0,08	0,08	0,12	0,15				
		S (mm / min)	111	111	67	80	84	74	89	93				
GHISA BC7	V/C 25 m/min	RPM	3979	2653	1592	1137	796	663	531	442	398	362	318	265
		mm / giro	0,05	0,08	0,10	0,20	0,27	0,31	0,37	0,41	0,42	0,42	0,42	0,45
		S (mm / min)	199	199	159	227	215	206	196	181	167	152	134	119
OTTONE BC66	V/C 50 m/min	RPM	7958	5305	3183	2274	1592	1326	1061	884	796	723	637	531
		mm / giro	0,04	0,07	0,08	0,17	0,21	0,25	0,28	0,28	0,30	0,30	0,33	0,40
		S (mm / min)	318	345	239	387	334	332	297	248	239	217	210	212
PLASTICA FIBRA DI CARBONIO BC7	V/C 12 m/min	RPM	1911	1274	764	546	382	318	255	212	191	174	153	127
		mm / giro	0,02	0,03	0,03	0,05	0,08	0,08	0,12	0,15				
		S (mm / min)	38	38	23	27	29	25	31	32				
LEGHE Ni BC42	V/C 30 m/min	RPM	4775	3183	1910	1364	955	796	637	531	477	434	382	318
		mm / giro	0,015	0,02	0,02	0,03	0,04	0,06	0,07	0,08	0,11	0,12	0,15	
		S (mm / min)	72	64	42	34	38	48	45	42	53	52	57	
CIRCUITI STAMPATI BC79	25	RPM	3979	-	-	-	-	-	-	-	-	-	-	

OSSERVAZIONI:

- Conosciuti il diametro della punta e il materiale da lavorare, la velocità e l'avanzamento si identificano velocemente.

esempio;

Materiale: Alluminio

RPM=2274

Ø Della punta: 7 mm

S=364 mm/min

- Prima di realizzare i primi fori è necessario regolare sia la velocità sia l'avanzamento.

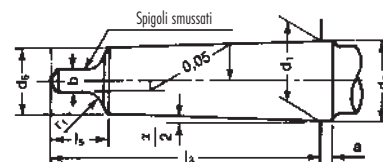
INFORMAZIONI TECNICHE SULLE DIMENSIONI DEL CONO MORSE DIN 228D

CONO MORSE	Assottigliamento	Ø 2	a	b h13	d ₁	d ₂ Ø maggiore	d ₆ Ø minore	d ₇ Dimen. Max.	l ₃ -1	l ₄ Dimen. Max.	l ₅ Dimen. Max.	r ₁	r ₂
0	1:19,212=0,05205	1°29 27"	3,0	3,9	9,045	9,2	6,1	6,0	56,5	59,5	10,5	4	1,0
1	1:20,047=0,04988	1°25 43"	3,5	5,2	12,065	12,2	9,0	8,7	62,0	65,5	13,5	5	1,2
2	1:20,020=0,04995	1°25 50"	5,0	6,3	17,780	18,0	14,0	13,5	75,0	80,0	16,0	6	1,6
3	1:19,922=0,05020	1°26 16"	5,0	7,0	23,825	24,1	19,1	18,5	94,0	99,0	20,0	7	2,0
4	1:19,254=0,05194	1°29 15"	6,5	11,9	31,267	31,6	25,2	24,5	117,5	124,0	24,0	8	2,5
5	1:19,002=0,05263	1°30 26"	6,5	15,9	44,399	44,7	36,5	35,7	149,5	156,0	29,0	10	3,0
6	1:19,180=0,05214	1°29 36"	8,0	19,0	63,348	63,8	52,4	51,0	210,0	218,0	40,0	10	4,0