

BLUE-MASTER[®]
by *celesa*



FORETS
MÉTAUX

FORETS CYLINDRIQUES DIN 338 TAILLÉS - MEULÉS



10 U. Ø 0,20 - Ø 10,50 mm

6 U. Ø 10,60 - Ø 14 mm

1 U. Ø 14,10 - Ø 20 mm

1 U. BC9-BC99
BC7-BC98-BC42



		BTX	TTX	BC51	BC95	BC55	BC57	BC50	BC7	BC98	BC42
MATÉRIEL		HSSCo 5%	HSS	HSSCo 5%	HSSCo 5%	HSSCo 5%	HSSCo 5%	HSSCo 5%	POINTE CARBURE	POINTE CARBURE	CARBURE
AFFÛTAGE											
ANGLE AFFÛTAGE		135°	135°	135°	130°	135°	135°	118°	118°	135°	135°
HÉLICE		38° "S"	38° "S"	30° "N"	Ø ≥ 3	38° "S"	38° "S"	38° "N"	30° "N"	30° "N"	35° "N"
FINITION		DORÉ	TiAlSiN	TiAlN	DORÉ OX	BRILLANT	TiAlN	TiAlN	BRILLANT	BRILLANT	BRILLANT
APPLICATION		120 Kg/mm²	80 Kg/mm²	HAUTE PERFORMANCE	INOX	INOX	INOX	INOX Plus	BRILLANT	BRILLANT	HAUTE PERFORMANCE
Ø mm	L1 x L2	€	€	€	€	€	€	€	€	€	€
0,20	19 x 2,50										
0,25	19 x 3										
0,30	19 x 3										
0,35	19 x 4										
0,40	20 x 5										
0,45	20 x 5										
0,50	22 x 6										13,61
0,55	24 x 7										
0,60	24 x 7										
0,65	26 x 8										
0,70	28 x 9										
0,75	28 x 9										
0,80	30 x 10										
0,85	30 x 10										
0,90	32 x 11										
0,95	32 x 11										
1,00	34 x 12			3,58	3,22	4,26	6,08				9,11
1,05	34 x 12										
1,10	36 x 14										9,48
1,15	36 x 14										
1,19	3/64"										
1,20	38 x 16					5,58	5,83				10,04
1,25	38 x 16										
1,30	38 x 16										10,29
1,35	40 x 18										
1,40	40 x 18										10,87
1,45	40 x 18										
1,50	40 x 18			3,62	2,88	3,46	6,07				10,97
1,55	43 x 20										

Ø 0,20-1,5mm

Forets pour métaux
Rose

FORETS CYLINDRIQUES DIN 338 TAILLÉS - MEULÉS
**DIN
338**

Forets pour métaux

Gris

Rose



		BC2	BC82	BC02	BC9	BC5	BC99	BC58	BC16	BC66	BC15	BC18
MATÉRIEL		HSS	HSS	HSS-G	HSS	HSSCo 5%	HSSCo 5%	HSSCo 8%	HSS	HSS	HSS	HSS
AFFÛTAGE												
ANGLE AFFÛTAGE		118°	118°	118°	118°	135°	135°	135°	135°	118°	118°	118°
HÉLICE												
FINITION		OX	BRILLANT	DORÉ OX	OX	DORÉ	DORÉ	DORÉ	BRILLANT	BRILLANT	OX	TiN
APPLICATION												
Ø mm	L1 x L2	€	€	€	€	€	€	€	€	€	€	€
1,59	1/16"	1,19				3,04						
1,60	43 x 20	1,74	1,74			2,93						2,49
1,65	43 x 20	1,74	1,74									
1,70	43 x 20	1,74	1,74			2,93						2,48
1,75	46 x 22	1,57	1,57			3,17		4,73	2,83	4,58		2,38
1,80	46 x 22	1,56	1,56			2,86						2,34
1,85	46 x 22	1,56	1,56									
1,90	46 x 22	1,56	1,56			3,19						2,34
1,95	48 x 24	1,56										
1,98	5/64"	1,42				2,99						
2,00	49 x 24	1,33	1,33	1,46		2,63		3,92	2,47	2,87	2,98	1,93
2,05	49 x 24	1,44	1,44									
2,10	49 x 24	1,44	1,44			3,10						2,18
2,15	53 x 27	1,44										
2,20	53 x 27	1,44	1,44			3,10						2,17
2,25	53 x 27	1,35	1,35	1,46		2,95		4,73	2,79	3,13		2,10
2,30	53 x 27	1,67	1,67			3,10						2,32
2,35	53 x 27	1,67	1,67									
2,38	3/32"	1,55				2,94						
2,40	57 x 30	1,66	1,66			3,10						2,32
2,45	57 x 30	1,66										
2,50	57 x 30	1,40	1,40	1,53		2,41		3,92	2,31	2,71	2,98	1,87
2,55	57 x 30	1,69	1,69									
2,60	57 x 30	1,69	1,69			2,98						2,33
2,65	57 x 30	1,69										
2,70	61 x 33	1,69	1,69	1,85		2,98						2,33
2,75	61 x 33	1,48	1,48	1,58		2,95		4,73	2,79	3,67		2,27
2,78	7/64"	1,62				2,84						
2,80	61 x 33	1,69	1,69	1,85		2,99						2,33

FORETS CYLINDRIQUES DIN 338 TAILLÉS - MEULÉS



10 U. Ø 0,20 - Ø 10,50 mm

6 U. Ø 10,60 - Ø 14 mm

1 U. Ø 14,10 - Ø 20 mm

BC9-BC99
BC7-BC98-BC42



		BTX	TTX	BC51	BC95	BC55	BC57	BC50	BC7	BC98	BC42
MATÉRIEL		HSSCo 5%	HSS	HSSCo 5%	HSSCo 5%	HSSCo 5%	HSSCo 5%	HSSCo 5%	POINTE CARBURE	POINTE CARBURE	CARBURE
AFFÛTAGE											
ANGLE AFFÛTAGE		135°	135°	135°	130°	135°	135°	118°	118°	135°	135°
HÉLICE		38° "S"	38° "S"	30° "N"	Ø ≥ 3	38° "S"	38° "S"	38° "N"	30° "N"	30° "N"	35° "N"
FINITION		DORÉ	TiAlSiN	TiAlN	DORÉ OX	BRILLANT	TiAlN	TiAlN	BRILLANT	BRILLANT	BRILLANT
APPLICATION											
Ø mm	L1 x L2	€	€	€	€	€	€	€	€	€	€
1,59	1/16"										
1,60	43 x 20					3,11					11,18
1,65	43 x 20					2,83					11,43
1,70	43 x 20					2,88					11,54
1,75	46 x 22				2,88						
1,80	46 x 22					2,97	5,97				11,82
1,85	46 x 22										
1,90	46 x 22					3,25					11,82
1,95	48 x 24										
1,98	5/64"										
2,00	49 x 24			3,77	2,88	4,18	6,09	6,06	19,22		11,82
2,05	49 x 24										
2,10	49 x 24					3,97			21,26		18,17
2,15	53 x 27										
2,20	53 x 27					3,76	6,45		21,26		19,53
2,25	53 x 27				2,88				21,26		
2,30	53 x 27					3,74			21,26		19,53
2,35	53 x 27										
2,38	3/32"										
2,40	57 x 30					4,52			21,26		19,88
2,45	57 x 30										
2,50	57 x 30			3,77	2,88	4,40	6,51	6,65	19,22		14,45
2,55	57 x 30										
2,60	57 x 30					4,85			21,26		24,53
2,65	57 x 30										
2,70	61 x 33					4,34			21,26		24,53
2,75	61 x 33			3,69	2,88				21,26		
2,78	7/64"										
2,80	61 x 33					4,50	8,61		21,26		24,53

Forets pour métaux
Rose

Ø 1,59-2,80mm

FORETS CYLINDRIQUES DIN 338 TAILLÉS - MEULÉS

Forets pour métaux

Gris
Rose
**DIN
338**

		BC2	BC82	BC02	BC9	BC5	BC99	BC58	BC16	BC66	BC15	BC18
MATÉRIEL		HSS	HSS	HSS-G	HSS	HSSCo 5%	HSSCo 5%	HSSCo 8%	HSS	HSS	HSS	HSS
AFFÛTAGE												
ANGLE AFFÛTAGE		118°	118°	118°	118°	135°	135°	135°	135°	118°	118°	118°
HÉLICE												
FINITION		OX	BRILLANT	DORÉ OX	OX	DORÉ	DORÉ	DORÉ	BRILLANT	BRILLANT	OX	TiN
APPLICATION												
Ø mm	L1 x L2	€	€	€	€	€	€	€	€	€	€	€
2,85	61 x 33	1,70										
2,90	61 x 33	1,69	1,69			2,98						2,33
2,95	61 x 33	1,69										
3,00	61 x 33	1,27	1,27	1,38		2,36		3,80	2,27	3,00	2,72	1,80
3,05	65 x 36	1,66										
3,10	65 x 36	1,48	1,48	1,57		2,86		5,08				2,28
3,15	65 x 36	1,66										
3,17	1/8"	1,41				2,72						
3,20	65 x 36	1,48	1,48	1,57		2,85		5,08	2,79			2,28
3,25	65 x 36	1,48	1,48	1,57		2,86		4,66	2,79	3,67		2,59
3,30	65 x 36	1,48	1,48	1,57		2,85		5,08	2,79			2,28
3,35	65 x 36	1,88										
3,40	70 x 39	1,88	1,88	2,05		2,99						2,80
3,45	70 x 39	1,91										
3,50	70 x 39	1,43	1,43	1,57		2,85		4,58	2,74	3,23	3,40	2,33
3,55	70 x 39	1,99										
3,57	9/64"	1,85				3,42						
3,60	70 x 39	1,99	1,99	2,16		3,59						2,56
3,65	70 x 39	1,99										
3,70	70 x 39	1,99	1,99	2,16		3,59						2,59
3,75	70 x 39	1,66	1,66	1,85		3,41		5,53	3,43	4,79		2,72
3,80	75 x 43	2,03	2,03	2,27		3,59						2,62
3,85	75 x 43	2,04										
3,90	75 x 43	2,02	2,02	2,27		3,59						2,59
3,95	75 x 43	2,02										
3,97	5/32"	1,93				3,42						
4,00	75 x 43	1,60	1,60	1,79		3,04		4,95	2,95	3,49	3,35	2,51
4,05	75 x 43	2,02										
4,10	75 x 43	1,82	1,82	1,99		3,41		6,10	3,34			2,79

FORETS CYLINDRIQUES DIN 338 TAILLÉS - MEULÉS



- 10 U. Ø 0,20 - Ø 10,50 mm
- 6 U. Ø 10,60 - Ø 14 mm
- 1 U. Ø 14,10 - Ø 20 mm
- 1 U. BC9-BC99
BC7-BC98-BC42



		BTX	TTX	BC51	BC95	BC55	BC57	BC50	BC7	BC98	BC42
MATÉRIEL		HSSCo 5%	HSS	HSSCo 5%	HSSCo 5%	HSSCo 5%	HSSCo 5%	HSSCo 5%	POINTE CARBURE	POINTE CARBURE	CARBURE
AFFÛTAGE											
ANGLE AFFÛTAGE		135°	135°	135°	130°	135°	135°	118°	118°	135°	135°
HÉLICE		38° "S"	38° "S"	30° "N"	Ø ≥ 3	38° "S"	38° "S"	38° "N"	30° "N"	30° "N"	35° "N"
FINITION		DORÉ	TiAlSiN	TiAlN	DORÉ OX	BRILLANT	TiAlN	TiAlN	BRILLANT	BRILLANT	BRILLANT
APPLICATION		120 Kg/mm²	80 Kg/mm²	HAUTE PERFORMANCE	INOX	INOX	INOX	INOX Plus	FORTE	70 Hrc	HAUTE PERFORMANCE
Ø mm	L1 x L2	€	€	€	€	€	€	€	€	€	€
2,85	61 x 33										
2,90	61 x 33					4,54			21,26		24,53
2,95	61 x 33										
3,00	61 x 33	2,37	2,25	3,44	2,82	3,28	5,60	6,75	17,96	15,49	19,47
3,05	65 x 36										
3,10	65 x 36					3,43	6,88		20,32		23,87
3,15	65 x 36										
3,17	1/8"										
3,20	65 x 36	2,89	2,76		3,45	3,43	6,93		19,94		23,87
3,25	65 x 36				3,46				20,32		
3,30	65 x 36	2,90	2,77	4,35	3,46	4,08	6,89	8,21	19,94	17,52	21,37
3,35	65 x 36										
3,40	70 x 39					4,15			20,32		26,16
3,45	70 x 39										
3,50	70 x 39	2,85	2,71	4,32	3,40	4,32	6,84	7,76	18,74	16,17	22,44
3,55	70 x 39										
3,57	9/64"										
3,60	70 x 39					4,51			20,32	17,52	27,42
3,65	70 x 39										
3,70	70 x 39					4,37			20,69		27,42
3,75	70 x 39				3,59				20,69		
3,80	75 x 43					4,37	9,08		20,69		28,75
3,85	75 x 43										
3,90	75 x 43					4,43			20,69		28,75
3,95	75 x 43										
3,97	5/32"										
4,00	75 x 43	3,11	2,96	4,46	3,70	4,60	7,21	8,40	18,42	15,74	23,93
4,05	75 x 43										
4,10	75 x 43					4,69	7,77		20,87		28,90

Forets pour métaux

Rose

Ø 2,85-4,10mm

FORETS CYLINDRIQUES DIN 338 TAILLÉS - MEULÉS

Forets pour métaux
Gris
Rose



		BC2	BC82	BC02	BC9	BC5	BC99	BC58	BC16	BC66	BC15	BC18
MATÉRIEL		HSS	HSS	HSS-G	HSS	HSSCo 5%	HSSCo 5%	HSSCo 8%	HSS	HSS	HSS	HSS
AFFÛTAGE												
ANGLE AFFÛTAGE		118°	118°	118°	118°	135°	135°	135°	135°	118°	118°	118°
HÉLICE		30° "N"	30° "N"	30° "N"	30° "N"	30° "N"	30° "N"	30° "N"	40° "W"	15° "H"	30° "N"	30° "N"
FINITION		OX	BRILLANT	DORÉ OX	OX	DORÉ	DORÉ	DORÉ	BRILLANT	BRILLANT	OX	TiN
APPLICATION												
Ø mm	L1 x L2	€	€	€	€	€	€	€	€	€	€	€
4,15	75 x 43	2,02										
4,20	75 x 43	1,82	1,82	1,99		3,41		6,10	3,34			2,79
4,25	75 x 43	1,82	1,82	2,00		3,41		5,53	3,74	5,18		2,79
4,30	80 x 47	2,40	2,40	2,69		3,59						2,98
4,35	80 x 47	2,38										
4,37	11/64"	2,26				3,42						
4,40	80 x 47	2,40	2,40	2,69		3,59						2,96
4,45	80 x 47	2,40										
4,50	80 x 47	1,88	1,88	2,02		3,50		5,53	3,30	4,26	3,84	2,82
4,55	80 x 47	2,43										
4,60	80 x 47	2,43	2,43			4,00						3,11
4,65	80 x 47	2,43										
4,70	80 x 47	2,46	2,46	2,69		4,00						3,11
4,75	80 x 47	2,16	2,16	2,41		3,80		6,13	4,21	6,26		3,00
4,76	3/16"	2,05				3,55						
4,80	86 x 52	2,73	2,73	2,93		4,03		6,74				3,30
4,85	86 x 52	2,65										
4,90	86 x 52	2,65	2,65	2,87		4,03						3,27
4,95	86 x 52	2,66										
5,00	86 x 52	1,88	1,88	2,20		3,67		5,93	3,52	4,62	4,42	2,88
5,05	86 x 52	2,74	2,74									
5,10	86 x 52	2,73	2,73	2,96		4,37		7,27	4,24		5,33	3,29
5,15	86 x 52	2,74										
5,16	13/64"	2,62				3,76						
5,20	86 x 52	2,73	2,73	2,96		4,37		7,27				3,30
5,25	86 x 52	2,56	2,56	2,84		4,31		6,97	5,04	7,02		3,28
5,30	86 x 52	3,40	3,40	3,68		4,38						3,73
5,35	93 x 57	3,38										
5,40	93 x 57	3,40	3,40			4,37						3,73

FORETS CYLINDRIQUES DIN 338 TAILLÉS - MEULÉS



- 10 U. Ø 0,20 - Ø 10,50 mm
- 6 U. Ø 10,60 - Ø 14 mm
- 1 U. Ø 14,10 - Ø 20 mm
- 1 U. BC9-BC99
BC7-BC98-BC42



		BTX	TTX	BC51	BC95	BC55	BC57	BC50	BC7	BC98	BC42
MATÉRIEL		HSSCo 5%	HSS	HSSCo 5%	HSSCo 5%	HSSCo 5%	HSSCo 5%	HSSCo 5%	POINTE CARBURE	POINTE CARBURE	CARBURE
AFFÛTAGE											
ANGLE AFFÛTAGE		135°	135°	135°	130°	135°	135°	118°	118°	135°	135°
HÉLICE		38° "S"	38° "S"	30° "N"	Ø ≥ 3	38° "S"	38° "S"	38° "N"	30° "N"	30° "N"	35° "N"
FINITION		DORÉ	TiAlSiN	TiAlN	DORÉ OX	BRILLANT	TiAlN	TiAlN	BRILLANT	BRILLANT	BRILLANT
APPLICATION											
Ø mm	L1 x L2	€	€	€	€	€	€	€	€	€	€
4,15	75 x 43										
4,20	75 x 43	3,47	3,30	4,70	4,12	4,76	7,76	9,46	20,87	18,33	28,03
4,25	75 x 43			4,70					21,67		
4,30	80 x 47					4,97	8,30		21,67	18,33	36,93
4,35	80 x 47										
4,37	11/64"										
4,40	80 x 47					4,97			21,67	18,33	37,67
4,45	80 x 47										
4,50	80 x 47	3,47	3,30	4,73	4,12	5,11	7,92	9,09	18,29	15,13	31,00
4,55	80 x 47										
4,60	80 x 47					5,82			20,87		33,54
4,65	80 x 47										
4,70	80 x 47					5,82			20,87		33,54
4,75	80 x 47				4,27				21,67		
4,76	3/16"										
4,80	86 x 52					6,15	8,79		20,87		34,39
4,85	86 x 52										
4,90	86 x 52					6,15			21,67		34,39
4,95	86 x 52										
5,00	86 x 52	4,11	3,91	4,85	4,40	5,52	8,14	9,12	18,76	14,82	31,90
5,05	86 x 52										
5,10	86 x 52					6,02	9,23		21,92	18,14	39,02
5,15	86 x 52										
5,16	13/64"										
5,20	86 x 52					6,37	9,30		21,28		39,02
5,25	86 x 52				5,25				22,74		
5,30	86 x 52					6,37			22,74		39,02
5,35	93 x 57										
5,40	93 x 57					6,43			22,74		44,15

Forets pour métaux
Rose

Ø 4,15-5,40mm

FORETS CYLINDRIQUES DIN 338 TAILLÉS - MEULÉS

Forets pour métaux

Gris

Rose

**DIN
338**

		BC2	BC82	BC02	BC9	BC5	BC99	BC58	BC16	BC66	BC15	BC18
MATÉRIEL		HSS	HSS	HSS-G	HSS	HSSCo 5%	HSSCo 5%	HSSCo 8%	HSS	HSS	HSS	HSS
AFFÛTAGE												
ANGLE AFFÛTAGE		118°	118°	118°	118°	135°	135°	135°	135°	118°	118°	118°
HÉLICE												
FINITION		OX	BRILLANT	DORÉ OX	OX	DORÉ	DORÉ	DORÉ	BRILLANT	BRILLANT	OX	TiN
APPLICATION												
Ø mm	L1 x L2	€	€	€	€	€	€	€	€	€	€	€
5,45	93 x 57	3,40										
5,50	93 x 57	2,66	2,66	2,93		4,62		7,48	4,47	5,65	5,10	3,32
5,55	93 x 57	3,62										
5,56	7/32"	1,19				5,22						
5,60	93 x 57	3,63	3,63	3,92		5,49		9,25				3,88
5,65	93 x 57	3,62										
5,70	93 x 57	3,63	3,63	3,92		5,49		9,25				3,88
5,75	93 x 57	3,47	3,47	3,81		5,21		8,37	6,17	8,59		3,84
5,80	93 x 57	3,38	3,38	3,77		5,49		9,25				3,73
5,85	93 x 57	3,40										
5,90	93 x 57	3,38	3,38	3,74		5,49						3,73
5,95	15/64"	3,20				5,72						
6,00	93 x 57	2,78	2,78	3,02		4,97		7,98	4,73	6,08	5,64	3,40
6,05	101 x 63	3,94										
6,10	101 x 63	3,94	3,94	4,38		6,15						6,13
6,15	101 x 63	4,03										
6,20	101 x 63	4,03	4,03	4,38		6,15						6,13
6,25	101 x 63	3,78	3,78	4,08		5,81		9,33	6,17	8,59		6,81
6,30	101 x 63	4,22	4,22			6,15						6,17
6,35	1/4"	3,03				5,85						
6,40	101 x 63	4,38	4,38			6,17						6,14
6,45	101 x 63	4,24										
6,50	101 x 63	3,29	3,29	3,58		5,96		9,30	5,51	6,77	6,97	5,81
6,55	101 x 63	5,33										
6,60	101 x 63	5,24	5,24			7,42						6,97
6,65	101 x 63	5,33										
6,70	101 x 63	5,30	5,30	5,65		7,42		11,92				6,97
6,75	109 x 69	3,99	3,99	4,31		6,94		10,88	7,43	10,36		6,93
6,80	109 x 69	3,99	3,99	4,31		6,94		11,92	6,47			6,94

FORETS CYLINDRIQUES DIN 338 TAILLÉS - MEULÉS



- 10 U. Ø 0,20 - Ø 10,50 mm
- 6 U. Ø 10,60 - Ø 14 mm
- 1 U. Ø 14,10 - Ø 20 mm
- BC9-BC99
BC7-BC98-BC42



		BTX	TTX	BC51	BC95	BC55	BC57	BC50	BC7	BC98	BC42
MATÉRIEL		HSSCo 5%	HSS	HSSCo 5%	HSSCo 5%	HSSCo 5%	HSSCo 5%	HSSCo 5%	POINTE CARBURE	POINTE CARBURE	CARBURE
AFFÛTAGE											
ANGLE AFFÛTAGE		135°	135°	135°	130°	135°	135°	118°	118°	135°	135°
HÉLICE		38° "S"	38° "S"	30° "N"	Ø ≥ 3	38° "S"	38° "S"	38° "N"	30° "N"	30° "N"	35° "N"
FINITION		DORÉ	TiAlSiN	TiAlN	DORÉ OX	BRILLANT	TiAlN	TiAlN	BRILLANT	BRILLANT	BRILLANT
APPLICATION		120 Kg/mm²	80 Kg/mm²	HAUTE PERFORMANCE	INOX	INOX	INOX	INOX Plus	FORTE	70 Hrc	HAUTE PERFORMANCE
Ø mm	L1 x L2	€	€	€	€	€	€	€	€	€	€
5,45	93 x 57										
5,50	93 x 57	5,21	4,96	5,48	5,58	7,01	9,73	10,16	19,65	15,80	40,14
5,55	93 x 57										
5,56	7/32"										
5,60	93 x 57					7,20			22,26		46,38
5,65	93 x 57										
5,70	93 x 57					7,06			22,93		46,38
5,75	93 x 57				5,86	7,13			23,79		
5,80	93 x 57					7,20	11,13		22,93		46,38
5,85	93 x 57										
5,90	93 x 57					7,12			23,79		46,38
5,95	15/64"										
6,00	93 x 57	5,54	5,26	5,67	5,93	7,36	10,24	10,84	20,35	16,84	44,19
6,05	101 x 63										
6,10	101 x 63				6,92	8,05			25,68		57,44
6,15	101 x 63										
6,20	101 x 63					8,34	16,05		25,68		57,44
6,25	101 x 63				6,92				25,68		
6,30	101 x 63					8,27			25,68		57,44
6,35	1/4"										
6,40	101 x 63					8,27			25,68		57,44
6,45	101 x 63										
6,50	101 x 63	6,47	6,15	10,55	6,92	8,27	15,77	12,77	22,72	17,16	55,14
6,55	101 x 63										
6,60	101 x 63					8,89			26,48		71,42
6,65	101 x 63										
6,70	101 x 63					8,89			26,48		71,42
6,75	109 x 69			11,06	7,79				26,48		
6,80	109 x 69	7,54	7,17	11,06	8,06	9,12	17,35		25,75	20,54	66,31

Forets pour métaux
Rose

Ø 5,45-6,80mm

FORETS CYLINDRIQUES DIN 338 TAILLÉS - MEULÉS

Forets pour métaux

Gris
Rose
**DIN
338**

		BC2	BC82	BC02	BC9	BC5	BC99	BC58	BC16	BC66	BC15	BC18
MATÉRIEL		HSS	HSS	HSS-G	HSS	HSSCo 5%	HSSCo 5%	HSSCo 8%	HSS	HSS	HSS	HSS
AFFÛTAGE												
ANGLE AFFÛTAGE		118°	118°	118°	118°	135°	135°	135°	135°	118°	118°	118°
HÉLICE		30° "N"	30° "N"	30° "N"	30° "N"	30° "N"	30° "N"	30° "N"	40° "W"	15° "H"	30° "N"	30° "N"
FINITION		OX	BRILLANT	DORÉ OX	OX	DORÉ	DORÉ	DORÉ	BRILLANT	BRILLANT	OX	TiN
APPLICATION												
Ø mm	L1 x L2	€	€	€	€	€	€	€	€	€	€	€
6,85	109 x 69	5,85										
6,90	109 x 69	5,86	5,86			7,42						7,02
6,95	109 x 69	5,86										
7,00	109 x 69	3,99	3,99	4,31		6,56		9,74	6,03	7,19	7,90	6,21
7,05	109 x 69	6,16										
7,10	109 x 69	6,15	6,15			9,42						8,14
7,14	9/32"	5,89				8,89						
7,15	109 x 69	6,17										
7,20	109 x 69	6,15	6,15			9,42					8,39	8,14
7,25	109 x 69	5,08	5,08	5,45		8,88		13,24	9,82	13,59		7,60
7,30	109 x 69	6,16	6,16			9,43						8,14
7,35	109 x 69	6,15										
7,40	109 x 69	6,16	6,16	6,65		9,43						8,14
7,45	109 x 69	6,36										
7,50	109 x 69	4,22	4,22	4,54		6,95		10,39	6,45	8,40	8,39	7,10
7,54	19/64"	6,89				10,77						
7,55	117 x 75	7,30										
7,60	117 x 75	7,26	7,26			11,36						8,42
7,65	117 x 75	7,30										
7,70	117 x 75	7,26	7,26			11,33						8,42
7,75	117 x 75	5,61	5,61	6,04		10,75		16,04	12,49	18,12		8,04
7,80	117 x 75	7,37	7,37	7,99		11,33						8,39
7,85	117 x 75	7,39										
7,90	117 x 75	7,37	7,37	7,99		11,39						8,39
7,94	5/16"	6,29				10,74						
7,95	117 x 75	7,37										
8,00	117 x 75	4,84	4,84	5,23		8,16		12,17	7,52	8,93	9,58	7,42
8,05	117 x 75	7,57										
8,10	117 x 75	7,57	7,57			10,91						9,81

FORETS CYLINDRIQUES DIN 338 TAILLÉS - MEULÉS



- 10 U. Ø 0,20 - Ø 10,50 mm
- 6 U. Ø 10,60 - Ø 14 mm
- 1 U. Ø 14,10 - Ø 20 mm
- 1 U. BC9-BC99
BC7-BC98-BC42



	BTX	TTX	BC51	BC95	BC55	BC57	BC50	BC7	BC98	BC42	
MATÉRIEL	HSSCo 5%	HSS	HSSCo 5%	HSSCo 5%	HSSCo 5%	HSSCo 5%	HSSCo 5%	POINTE CARBURE	POINTE CARBURE	CARBURE	
AFFÛTAGE											
ANGLE AFFÛTAGE	135°	135°	135°	130°	135°	135°	118°	118°	135°	135°	
HÉLICE	38° "S"	38° "S"	30° "N"	Ø ≥ 3	38° "S"	38° "S"	38° "N"	30° "N"	30° "N"	35° "N"	
FINITION	DORÉ	TiAlSiN	TiAlN	DORÉ OX	BRILLANT	TiAlN	TiAlN	BRILLANT	BRILLANT	BRILLANT	
APPLICATION	120 Kg/mm²	80 Kg/mm²	HAUTE PERFORMANCE	INOX	INOX	INOX	INOX Plus	FORTE	70 HRc	HAUTE PERFORMANCE	
Ø mm	L1 x L2	€	€	€	€	€	€	€	€	€	
6,85	109 x 69										
6,90	109 x 69					9,22		26,48	20,54	71,42	
6,95	109 x 69										
7,00	109 x 69	7,09	6,73	11,14	7,58	9,57	16,86	13,34	24,76	19,21	64,19
7,05	109 x 69										
7,10	109 x 69					10,01		27,77	22,11	81,69	
7,14	9/32"										
7,15	109 x 69										
7,20	109 x 69					10,09	19,95	27,77		81,69	
7,25	109 x 69				8,00			27,77			
7,30	109 x 69					10,51		27,77		81,69	
7,35	109 x 69										
7,40	109 x 69					10,65		27,77		81,69	
7,45	109 x 69										
7,50	109 x 69	7,52	7,14	11,44	8,04	10,64	17,57	14,83	25,56	20,19	70,35
7,54	19/64"										
7,55	117 x 75										
7,60	117 x 75					11,29		29,83		81,69	
7,65	117 x 75										
7,70	117 x 75					11,92		29,83		81,69	
7,75	117 x 75				9,23			29,83			
7,80	117 x 75					11,92	20,84	29,83		81,69	
7,85	117 x 75										
7,90	117 x 75					11,92		29,83		81,69	
7,94	5/16"										
7,95	117 x 75										
8,00	117 x 75	8,46	8,03	12,13	9,43	12,00	19,39	14,75	27,52	22,55	78,55
8,05	117 x 75										
8,10	117 x 75					12,02		31,86		95,04	

Ø 6,85-8,10mm

Forets pour métaux
Rose

FORETS CYLINDRIQUES DIN 338 TAILLÉS - MEULÉS



- 10 U.** Ø 0,20 - Ø 10,50 mm
- 6 U.** Ø 10,60 - Ø 14 mm
- 1 U.** Ø 14,10 - Ø 20 mm
- 1 U.** BC9-BC99
BC7-BC98-BC42



		BTX	TTX	BC51	BC95	BC55	BC57	BC50	BC7	BC98	BC42
MATÉRIEL		HSSCo 5%	HSS	HSSCo 5%	HSSCo 5%	HSSCo 5%	HSSCo 5%	HSSCo 5%	POINTE CARBURE	POINTE CARBURE	CARBURE
AFFÛTAGE											
ANGLE AFFÛTAGE		135°	135°	135°	130°	135°	135°	118°	118°	135°	135°
HÉLICE		38° "S"	38° "S"	30° "N"	Ø ≥ 3	38° "S"	38° "S"	38° "N"	30° "N"	30° "N"	35° "N"
FINITION		DORÉ	TiAlSiN	TiAlN	DORÉ OX	BRILLANT	TiAlN	TiAlN	BRILLANT	BRILLANT	BRILLANT
APPLICATION											
		120 Kg/mm ²	80 Kg/mm ²	HAUTE PERFORMANCE	INOX	INOX	INOX	INOX Plus	FORTE	70 HRc	HAUTE PERFORMANCE
Ø mm	L1 x L2	€	€	€	€	€	€	€	€	€	€
8,15	117 x 75										
8,20	117 x 75					12,08	25,07				95,04
8,25	117 x 75				9,69				31,86		
8,30	117 x 75					12,54			31,86		95,04
8,33	21/64"										
8,35	117 x 75										
8,40	117 x 75					12,54			31,86		95,04
8,45	117 x 75										
8,50	117 x 75	9,19	8,72	13,57	9,83	12,93	21,07	16,26	28,56	22,55	91,37
8,55	125 x 81										
8,60	125 x 81					14,38			34,22	27,27	110,16
8,65	125 x 81										
8,70	125 x 81					14,45			34,22		110,16
8,73	11/32"										
8,75	125 x 81				12,04				34,22		
8,80	125 x 81					14,88	27,65		34,22		110,16
8,85	125 x 81										
8,90	125 x 81					14,86			34,22		110,16
8,95	125 x 81										
9,00	125 x 81	11,02	10,48	15,03	12,54	15,38	24,78	17,98	29,55	24,45	99,32
9,05	125 x 81										
9,10	125 x 81				12,98	15,50			37,00		121,01
9,13	23/64"										
9,15	125 x 81										
9,20	125 x 81				12,98	15,76	28,60		37,00		121,01
9,25	125 x 81				12,98				37,00		
9,30	125 x 81				12,98	17,28			37,00		121,01
9,35	125 x 81										
9,40	125 x 81					17,28			37,00		121,01
9,45	125 x 81										

Forets pour métaux
Rose

Ø 8,15-9,45mm

FORETS CYLINDRIQUES DIN 338 TAILLÉS - MEULÉS

Forets pour métaux
Gris
Rose



		BC2	BC82	BC02	BC9	BC5	BC99	BC58	BC16	BC66	BC15	BC18
MATÉRIEL		HSS	HSS	HSS-G	HSS	HSSCo 5%	HSSCo 5%	HSSCo 8%	HSS	HSS	HSS	HSS
AFFÛTAGE												
ANGLE AFFÛTAGE		118°	118°	118°	118°	135°	135°	135°	135°	118°	118°	118°
HÉLICE		30° "N"	30° "N"	30° "N"	30° "N"	30° "N"	30° "N"	30° "N"	40° "W"	15° "H"	30° "N"	30° "N"
FINITION		OX	BRILLANT	DORÉ OX	OX	DORÉ	DORÉ	DORÉ	BRILLANT	BRILLANT	OX	TiN
APPLICATION												
Ø mm	L1 x L2	€	€	€	€	€	€	€	€	€	€	€
9,50	125 x 81	6,95	6,95	7,46		11,17		16,89	10,37	12,89	13,44	9,45
9,52	3/8"	6,50				10,64						
9,55	133 x 87	11,94										
9,60	133 x 87	11,47	11,47			17,98						12,58
9,65	133 x 87	11,62										
9,70	133 x 87	11,47	11,47			17,98						12,47
9,75	133 x 87	8,60	8,60	9,38		16,93		25,70	16,97	28,85		10,70
9,80	133 x 87	11,54	11,54			17,98						12,40
9,85	133 x 87	11,66										
9,90	133 x 87	11,66	11,66	12,65		17,98						12,40
9,92	25/64"	11,11				16,97						
9,95	133 x 87	11,65										
10,00	133 x 87	7,45	7,45	8,02	12,08	12,34		18,65	11,48	13,40	14,78	9,80
10,10	133 x 87	10,01	10,01	10,79		20,68						
10,20	133 x 87	9,29	9,29	10,01		17,43		33,72				15,36
10,25	133 x 87	10,37	10,37	12,39	15,92	21,32		33,72	18,85	32,89		17,46
10,30	133 x 87	11,66	11,66	12,52		20,72						
10,32	13/32"	11,11				19,65						
10,40	133 x 87	11,66	11,66			20,68						
10,50	133 x 87	9,26	9,26	9,99	13,59	17,44	26,51	27,44	15,32	16,10	18,72	14,23
10,60	133 x 87	12,80	12,80			24,04						
10,70	142 x 94	12,80	12,80			24,04						
10,72	27/64"	11,38				23,56						
10,75	142 x 94	11,97	11,97	12,76	18,00	24,99		39,23	22,04	30,02		18,01
10,80	142 x 94	14,19	14,19			24,04						
10,90	142 x 94	14,19	14,19			24,09						
11,00	142 x 94	10,82	10,82	11,67	15,33	19,26	28,31	30,24	16,63	17,91	22,32	14,98
11,10	142 x 94	14,49	14,49			27,43						
11,11	7 / 16"	13,79				25,87						
11,20	142 x 94	14,49	14,49			27,43						

FORETS CYLINDRIQUES DIN 338 TAILLÉS - MEULÉS



10 U. Ø 0,20 - Ø 10,50 mm

6 U. Ø 10,60 - Ø 14 mm

1 U. Ø 14,10 - Ø 20 mm

1 U. BC9-BC99
BC7-BC98-BC42



		BTX	TTX	BC51	BC95	BC55	BC57	BC50	BC7	BC98	BC42
MATÉRIEL		HSSCo 5%	HSS	HSSCo 5%	HSSCo 5%	HSSCo 5%	HSSCo 5%	HSSCo 5%	POINTE CARBURE	POINTE CARBURE	CARBURE
AFFÛTAGE											
ANGLE AFFÛTAGE		135°	135°	135°	130°	135°	135°	118°	118°	135°	135°
HÉLICE		38° "S"	38° "S"	30° "N"	Ø ≥ 3	38° "S"	38° "S"	38° "N"	30° "N"	30° "N"	35° "N"
FINITION		DORÉ	TiAlSiN	TiAlN	DORÉ OX	BRILLANT	TiAlN	TiAlN	BRILLANT	BRILLANT	BRILLANT
APPLICATION		120 Kg/mm ²	80 Kg/mm ²	HAUTE PERFORMANCE	INOX	INOX	INOX	INOX Plus	FORTE	70 HRC	HAUTE PERFORMANCE
Ø mm	L1 x L2	€	€	€	€	€	€	€	€	€	€
9,50	125 x 81	11,95	11,35	15,26	12,98	16,81	25,20	19,03	32,24	26,67	116,36
9,52	3/8"										
9,55	133 x 87										
9,60	133 x 87					17,28			39,69		128,34
9,65	133 x 87										
9,70	133 x 87					18,30			39,69		128,34
9,75	133 x 87								39,69		
9,80	133 x 87					18,38	31,23		39,69		128,34
9,85	133 x 87										
9,90	133 x 87					18,12			39,69		128,34
9,92	25/64"										
9,95	133 x 87										
10,00	133 x 87	12,41	11,78	16,01	14,28	19,46	27,11	19,79	33,07	27,37	121,97
10,10	133 x 87								44,44		
10,20	133 x 87	14,46	13,73	27,57	19,27	20,31	38,36	26,19	42,82	35,42	145,94
10,25	133 x 87				19,28				44,44		
10,30	133 x 87								44,44	35,42	
10,32	13/32"										
10,40	133 x 87								44,44		
10,50	133 x 87	15,08	14,33	27,55	19,28	22,05	39,20	25,49	39,72	35,15	136,31
10,60	133 x 87								47,28		
10,70	142 x 94								47,28		
10,72	27/64"										
10,75	142 x 94				20,94				47,28		
10,80	142 x 94					22,65			47,28		
10,90	142 x 94								47,28		
11,00	142 x 94	16,64	15,80	28,72	21,28	28,40	41,27	28,20	42,66	35,31	166,56
11,10	142 x 94				21,78				50,65		
11,11	7 / 16"										
11,20	142 x 94				22,80	29,47			50,65		

Rose Forets pour métaux

Ø 9,50-11,20mm

FORETS CYLINDRIQUES DIN 338 TAILLÉS - MEULÉS

Forets pour métaux

Gris

Rose

**DIN
338**

		BC2	BC82	BC02	BC9	BC5	BC99	BC58	BC16	BC66	BC15	BC18
MATÉRIEL		HSS	HSS	HSS-G	HSS	HSSCo 5%	HSSCo 5%	HSSCo 8%	HSS	HSS	HSS	HSS
AFFÛTAGE												
ANGLE AFFÛTAGE		118°	118°	118°	118°	135°	135°	135°	135°	118°	118°	118°
HÉLICE												
FINITION		OX	BRILLANT	DORÉ OX	OX	DORÉ	DORÉ	DORÉ	BRILLANT	BRILLANT	OX	TiN
APPLICATION												
Ø mm	L1 x L2	€	€	€	€	€	€	€	€	€	€	€
11,25	142 x 94	12,28	12,28	13,72	19,04	28,45		46,01	29,02	39,55		18,17
11,30	142 x 94	14,19	14,19			27,41						
11,40	142 x 94	14,19	14,19			27,43						
11,50	142 x 94	11,54	11,54	12,50	16,24	23,04	30,63	38,69	19,66	21,54	25,37	15,99
11,51	29/64"	11,00				21,85						
11,60	142 x 94	14,19	14,19			28,31						
11,70	142 x 94	14,19	14,19			28,31						
11,75	142 x 94	12,28	12,28	14,13	20,75	29,42		49,51	28,47	39,55		18,17
11,80	142 x 94	15,56	15,56			28,31						
11,90	151 x 101	15,56	15,56			28,31						
11,91	15/32"	14,81				26,83						
12,00	151 x 101	12,92	12,92	13,93	17,70	24,57	32,84	41,44	21,08	23,32	27,24	17,48
12,10	151 x 101	18,11	18,11			32,90						
12,20	151 x 101	18,11	18,11			32,90						
12,25	151 x 101	16,01	16,01	17,32	22,53	34,04		59,10	39,56	53,91		23,21
12,30	151 x 101	17,06	17,06			32,90						
12,40	151 x 101	17,06	17,06			32,90						
12,50	151 x 101	14,20	14,20	15,27	19,21	30,00	39,95	52,00	23,45	26,45	31,11	19,53
12,60	151 x 101	17,70	17,70			34,20						
12,70	1/2"	15,65				32,57						
12,75	151 x 101	15,73	15,73	17,31	23,21	35,54		61,72	43,67	59,87		23,02
12,80	151 x 101	19,73	19,73			34,20						
12,90	151 x 101	19,73	19,73			34,20						
13,00	151 x 101	14,66	14,66	15,73	19,75	30,70	42,17	52,74	23,79	28,45	33,48	20,87
13,10	151 x 101	20,19	20,19									
13,20	151 x 101	20,19	20,19									
13,25	160 x 108	23,04	23,04		28,22	42,51						
13,30	160 x 108	31,28	31,28									
13,40	160 x 108	31,28	31,28									
13,49	17/32"	19,79				32,23						

FORETS CYLINDRIQUES DIN 338 TAILLÉS - MEULÉS



- 10 U.** Ø 0,20 - Ø 10,50 mm
- 6 U.** Ø 10,60 - Ø 14 mm
- 1 U.** Ø 14,10 - Ø 20 mm
- 1 U.** BC9-BC99
BC7-BC98-BC42



		BTX	TTX	BC51	BC95	BC55	BC57	BC50	BC7	BC98	BC42
MATÉRIEL		HSSCo 5%	HSS	HSSCo 5%	HSSCo 5%	HSSCo 5%	HSSCo 5%	HSSCo 5%	POINTE CARBURE	POINTE CARBURE	CARBURE
AFFÛTAGE											
ANGLE AFFÛTAGE		135°	135°	135°	130°	135°	135°	118°	118°	135°	135°
HÉLICE		38° "S"	38° "S"	30° "N"	Ø ≥ 3	38° "S"	38° "S"	38° "N"	30° "N"	30° "N"	35° "N"
FINITION		DORÉ	TiAlSiN	TiAlN	DORÉ OX	BRILLANT	TiAlN	TiAlN	BRILLANT	BRILLANT	BRILLANT
APPLICATION		120 Kg/mm²	80 Kg/mm²	HAUTE PERFORMANCE	INOX	INOX	INOX	INOX Plus	FORTE	70 Hrc	HAUTE PERFORMANCE
Ø mm	L1 x L2	€	€	€	€	€	€	€	€	€	€
11,25	142 x 94				23,67				50,65		
11,30	142 x 94				23,84				50,65		
11,40	142 x 94								50,65		
11,50	142 x 94	19,15	18,20	30,50	24,49	29,02	43,50	30,62	49,05	40,57	177,00
11,51	29/64"										
11,60	142 x 94								55,84	44,50	
11,70	142 x 94								55,84		
11,75	142 x 94				25,71				55,84		
11,80	142 x 94					31,99			55,84		
11,90	151 x 101								55,84		
11,91	15/32"										
12,00	151 x 101	20,20	19,20	31,55	26,25	33,96	49,84	31,00	48,80	40,38	214,62
12,10	151 x 101								58,78	46,84	
12,20	151 x 101								58,78		
12,25	151 x 101								58,78		
12,30	151 x 101								58,78		
12,40	151 x 101								58,78		
12,50	151 x 101	23,13	21,98	39,00	32,05	38,36	52,22	35,09	58,50		256,01
12,60	151 x 101								62,10		
12,70	1/2"								62,10		
12,75	151 x 101								62,10		
12,80	151 x 101								62,10		
12,90	151 x 101								62,10		
13,00	151 x 101	24,93	23,68	39,57	32,52	39,44	51,75	36,68	58,40		237,05
13,10	151 x 101										
13,20	151 x 101										
13,25	160 x 108										
13,30	160 x 108										
13,40	160 x 108										
13,49	17/32"										

Forets pour métaux
Rose

Ø 11,25-13,49mm

FORETS CYLINDRIQUES DIN 338 TAILLÉS - MEULÉS

Forets pour métaux

Gris

Rose

**DIN
338**

		BC2	BC82	BC02	BC9	BC5	BC99	BC58	BC16	BC66	BC15	BC18
MATÉRIEL		HSS	HSS	HSS-G	HSS	HSSCo 5%	HSSCo 5%	HSSCo 8%	HSS	HSS	HSS	HSS
AFFÛTAGE												
ANGLE AFFÛTAGE		118°	118°	118°	118°	135°	135°	135°	135°	118°	118°	118°
HÉLICE												
FINITION		OX	BRILLANT	DORÉ OX	OX	DORÉ	DORÉ	DORÉ	BRILLANT	BRILLANT	OX	TiN
APPLICATION				<i>Plus</i>								
Ø mm	L1 x L2	€	€	€	€	€	€	€	€	€	€	€
13,50	160 x 108	20,79	20,79	22,45	26,32	33,84	44,78	58,13				27,27
13,60	160 x 108	31,28	31,28									
13,70	160 x 108	31,28	31,28									
13,75	160 x 108	23,31	23,31		30,26	42,51						
13,80	160 x 108	29,81	29,81									
13,89	35/64"	28,52				38,04						
13,90	160 x 108	29,94	29,94									
14,00	160 x 108	22,25	22,25	24,03	27,95	33,44	49,44	57,46				28,17
14,10	169 x 114	31,91										
14,20	169 x 114	31,91										
14,25	169 x 114	26,09	26,09		32,32	55,80						
14,29	9/16"	30,91				42,08						
14,30	169 x 114	32,46										
14,40	169 x 114	32,46										
14,50	169 x 114	24,04	24,04		30,23	47,43	63,18	81,48				29,21
14,60	169 x 114	33,06										
14,68	37/64"	24,85				53,15						
14,70	169 x 114	33,06										
14,75	169 x 114	26,09	26,09		37,11	55,80						
14,80	169 x 114	31,86										
14,90	169 x 114	31,86										
15,00	169 x 114	24,26	24,26	26,17	30,51	48,15	65,99	82,70				29,48
15,08	19/32"	23,10				45,86						
15,25	178 x 120	35,69			38,69	77,03						
15,48	39/64"	34,35				73,35						
15,50	178 x 120	28,40	28,40		35,24	55,69	73,63	95,62				32,06
15,75	178 x 120	36,07			40,08	77,01						
15,88	5/8"	28,12				55,05						
16,00	178 x 120	29,51	29,51		36,51	57,80	75,85	99,40				32,69
16,25	184 x 125	53,05			47,02							

FORETS CYLINDRIQUES DIN 338 TAILLÉS - MEULÉS



10 U. Ø 0,20 - Ø 10,50 mm

6 U. Ø 10,60 - Ø 14 mm

1 U. Ø 14,10 - Ø 20 mm

1 U. BC9-BC99
BC7-BC98-BC42



	BTX	TTX	BC51	BC95	BC55	BC57	BC50	BC7	BC98	BC42
MATÉRIEL	HSSCo 5%	HSS	HSSCo 5%	HSSCo 5%	HSSCo 5%	HSSCo 5%	HSSCo 5%	POINTE CARBURE	POINTE CARBURE	CARBURE
AFFÛTAGE										
ANGLE AFFÛTAGE	135°	135°	135°	130°	135°	135°	118°	118°	135°	135°
HÉLICE	38° "S"	38° "S"	30° "N"	Ø ≥ 3	38° "S"	38° "S"	38° "N"	30° "N"	30° "N"	35° "N"
FINITION	DORÉ	TiAlSiN	TiAlN	DORÉ OX	BRILLANT	TiAlN	TiAlN	BRILLANT	BRILLANT	BRILLANT
APPLICATION	120 Kg/mm²	80 Kg/mm²	HAUTE PERFORMANCE	INOX	INOX	INOX	INOX Plus	BRILLANT	70 Hrc	HAUTE PERFORMANCE
Ø mm	L1 x L2	€	€	€	€	€	€	€	€	€
13,50	160 x 108							66,86		
13,60	160 x 108									
13,70	160 x 108									
13,75	160 x 108									
13,80	160 x 108									
13,89	35/64"									
13,90	160 x 108									
14,00	160 x 108							67,99		
14,10	169 x 114									
14,20	169 x 114									
14,25	169 x 114									
14,29	9/16"									
14,30	169 x 114									
14,40	169 x 114									
14,50	169 x 114							75,93		
14,60	169 x 114									
14,68	37/64"									
14,70	169 x 114									
14,75	169 x 114									
14,80	169 x 114									
14,90	169 x 114									
15,00	169 x 114							77,83		
15,08	19/32"									
15,25	178 x 120									
15,48	39/64"									
15,50	178 x 120							94,53		
15,75	178 x 120									
15,88	5/8"									
16,00	178 x 120							89,79		
16,25	184 x 125									

Forets pour métaux
Rose

Ø 13,50-16,25mm

FORETS CYLINDRIQUES DIN 338 TAILLÉS - MEULÉS

Forets pour métaux

Gris

Rose

**DIN
338**

à gauche

		BC2	BC82	BC02	BC9	BC5	BC99	BC58	BC16	BC66	BC15	BC18
MATÉRIEL		HSS	HSS	HSS-G	HSS	HSSCo 5%	HSSCo 5%	HSSCo 8%	HSS	HSS	HSS	HSS
AFFÛTAGE												
ANGLE AFFÛTAGE		118°	118°	118°	118°	135°	135°	135°	135°	118°	118°	118°
HÉLICE												
FINITION		OX	BRILLANT	DORÉ OX	OX	DORÉ	DORÉ	DORÉ	BRILLANT	BRILLANT	OX	TiN
APPLICATION				<i>Plus</i>								
Ø mm	L1 x L2	€	€	€	€	€	€	€	€	€	€	€
16,50	184 x 125	34,35	34,35		40,91	66,00	86,49					
16,75	184 x 125	55,57			46,13							
17,00	184 x 125	34,39	34,39		40,91	66,00	87,05					
17,25	191 x 130	57,65			51,94							
17,50	191 x 130	39,42	39,42		46,56	73,14	95,83					
17,75	191 x 130	63,85			54,79							
18,00	191 x 130	41,76	41,76		49,08	79,66	104,99					
18,25	198 x 135	62,64			66,86							
18,50	198 x 135	46,31	46,31		54,16	87,98	117,15					
18,75	198 x 135	64,36			61,85							
19,00	198 x 135	46,31	46,31		54,16	87,98	116,14					
19,25	205 x 140	84,11			66,02							
19,50	205 x 140	49,79	49,79		58,78	97,58	128,68					
19,75	205 x 140	81,87			73,94							
20,00	205 x 140	56,56	56,56		67,75	104,71	137,87					
20,50	205 x 140				78,60		164,14					
21,00	205 x 140				71,75		169,97					
21,50	209 x 140				83,44		197,68					
22,00	209 x 140				79,33		200,58					
22,50	214 x 140				84,85		214,54					
23,00	214 x 140				86,87		233,10					
23,50	220 x 145				96,44		258,77					
24,00	220 x 145				95,36		290,61					
24,50	225 x 150				102,74		313,11					
25,00	225 x 150				104,28		333,94					
26,00	243 x 157				125,09		340,17					
27,00	243 x 157				134,34		349,35					
28,00	253 x 167				139,00		384,85					
29,00	253 x 167				163,16		413,93					
30,00	258 x 171				171,52		428,42					

FORETS CYLINDRIQUES DIN 338 TAILLÉS - MEULÉS



10 U. Ø 0,20 - Ø 10,50 mm

6 U. Ø 10,60 - Ø 14 mm

3 U. Ø 14,10 - Ø 20 mm

1 U. BC9-BC99
BC7-BC98-BC42



	BTX	TTX	BC51	BC95	BC55	BC57	BC50	BC7	BC98	BC42
MATÉRIEL	HSSCo 5%	HSS	HSSCo 5%	HSSCo 5%	HSSCo 5%	HSSCo 5%	HSSCo 5%	POINTE CARBURE	POINTE CARBURE	CARBURE
AFFÛTAGE										
ANGLE AFFÛTAGE	135°	135°	135°	130°	135°	135°	118°	118°	135°	135°
HÉLICE	38° "S"	38° "S"	30° "N"	Ø ≥ 3	38° "S"	38° "S"	38° "N"	30° "N"	30° "N"	35° "N"
FINITION	DORÉ	TiAlSiN	TiAlN	DORÉ OX	BRILLANT	TiAlN	TiAlN	BRILLANT	BRILLANT	BRILLANT
APPLICATION	120 Kg/mm²	80 Kg/mm²	HAUTE PERFORMANCE	INOX	INOX	INOX	INOX Plus	FORTE	70 Hrc	HAUTE PERFORMANCE
Ø mm	L1 x L2	€	€	€	€	€	€	€	€	€
16,50	184 x 125							131,26		
16,75	184 x 125									
17,00	184 x 125							103,50		
17,25	191 x 130									
17,50	191 x 130							147,19		
17,75	191 x 130									
18,00	191 x 130							113,83		
18,25	198 x 135									
18,50	198 x 135							175,46		
18,75	198 x 135									
19,00	198 x 135							138,34		
19,25	205 x 140									
19,50	205 x 140							199,68		
19,75	205 x 140									
20,00	205 x 140							157,46		
20,50	205 x 140									
21,00	205 x 140									
21,50	209 x 140									
22,00	209 x 140									
22,50	214 x 140									
23,00	214 x 140									
23,50	220 x 145									
24,00	220 x 145									
24,50	225 x 150									
25,00	225 x 150									
26,00	243 x 157									
27,00	243 x 157									
28,00	253 x 167									
29,00	253 x 167									
30,00	258 x 171									

Forets pour métaux
Rose

Ø 16,50-30mm

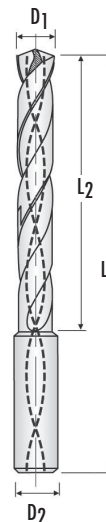
FORETS CARBURE DIAM <3 mm DIN 6537K/DIN6537L AVEC OU SANS TROUS D'HUILE
NEWRéf. BC84
Réf. BC97**CARBURE****TOL D1**
m7**TOL D2**
h6**TiAIN****HARDOX**
450**HAUTE**
PERFORMANCE**3xD****5xD**

Foret spécial pour HARDOX 450

BC84

DIN 6537K	D1 mm	D2 mm	L1 mm	L2 mm	€
BC840100	1,00	3	47	6,0	53,94
BC840110	1,10	3	47	6,6	53,94
BC840120	1,20	3	47	7,2	57,34
BC840130	1,30	3	47	7,8	57,34
BC840140	1,40	3	47	8,4	57,34
BC840150	1,50	3	47	9,0	57,34
BC840160	1,60	3	47	9,6	60,47
BC840170	1,70	3	47	10,2	60,47
BC840180	1,80	3	52	10,8	60,47
BC840190	1,90	3	52	11,4	60,47
BC840200	2,00	4	59	12,0	68,44
BC840210	2,10	4	59	12,6	68,44
BC840220	2,20	4	59	13,2	68,44
BC840230	2,30	4	59	13,8	68,44
BC840240	2,40	4	59	14,4	73,77
BC840250	2,50	4	59	15,0	73,77
BC840260	2,60	4	59	15,6	73,77
BC840270	2,70	4	59	16,2	73,77
BC840280	2,80	4	59	16,8	76,38
BC840290	2,90	4	59	17,4	76,38

BC97

DIN 6537L	D1 mm	D2 mm	L1 mm	L2 mm	€
BC970100	1,00	3	47	8,0	54,71
BC970110	1,10	3	47	8,8	57,34
BC970120	1,20	3	52	10,8	60,47
BC970130	1,30	3	52	11,7	62,58
BC970140	1,40	3	52	12,6	62,58
BC970150	1,50	3	52	13,5	62,58
BC970160	1,60	3	52	14,4	68,44
BC970170	1,70	3	52	15,3	68,44
BC970180	1,80	3	52	16,2	68,44
BC970190	1,90	3	52	17,1	68,44
BC970200	2,00	4	63	18,0	76,38
BC970210	2,10	4	63	18,9	76,38
BC970220	2,20	4	63	19,8	76,38
BC970230	2,30	4	63	20,7	77,72
BC970240	2,40	4	63	21,6	80,33
BC970250	2,50	4	63	22,5	80,33
BC970260	2,60	4	67	23,4	82,93
BC970270	2,70	4	67	24,3	82,93
BC970280	2,80	4	67	25,2	85,63
BC970290	2,90	4	67	26,1	85,63

FORETS CARBURE DIN 6537K AVEC OU SANS TROUS D'HUILE

Réf. BC84
Réf. BC83

3xD

**DIN
6537K**

CARBURE

**TOL D1
m7**

**TOL D2
h6**

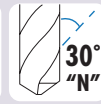





TiAIN

**HARDOX
450**

**HAUTE
PERFORMANCE**

Foret spécial pour HARDOX 450

BC84						BC83		BC84						BC83	
	D1 mm	D2 mm	L1 mm	L2 mm	€		€		D1 mm	D2 mm	L1 mm	L2 mm	€		€
BC840300	3,00	6	62	20	47,22	BC830300	83,63	BC840940	9,4	10	89	47	63,72	BC830940	111,26
BC840310	3,10	6	62	20	47,22	BC830310	83,63	BC840950	9,5	10	89	47	63,72	BC830950	111,26
BC840320	3,20	6	62	20	47,22	BC830320	83,63	BC840960	9,6	10	89	47	63,72	BC830960	111,26
BC840340	3,40	6	62	20	47,22	BC830300	83,63	BC840970	9,7	10	89	47	63,72	BC830970	111,26
BC840350	3,50	6	62	20	47,22	BC830350	83,63	BC840980	9,8	10	89	47	63,72	BC830980	111,26
BC840380	3,80	6	66	24	47,22	BC830380	83,63	BC840990	9,9	10	89	47	63,72	BC830990	111,26
BC840400	4,00	6	66	24	47,22	BC830400	83,63	BC841000	10,0	10	89	47	63,72	BC831000	111,26
BC840420	4,20	6	66	24	47,22	BC830420	83,63	BC841020	10,2	12	102	55	95,56	BC831020	159,01
BC840425	4,25	6	66	24	47,22	BC830425	83,63	BC841040	10,4	12	102	55	95,56	BC831040	159,01
BC840440	4,40	6	66	24	47,22	BC830440	83,63	BC841050	10,5	12	102	55	95,56	BC831050	159,01
BC840450	4,50	6	66	24	47,22	BC830450	83,63	BC841060	10,6	12	102	55	95,56	BC831060	159,01
BC840470	4,70	6	66	24	47,22	BC830470	83,63	BC841070	10,7	12	102	55	95,56	BC831070	159,01
BC840480	4,80	6	66	28	47,22	BC830480	83,63	BC841080	10,8	12	102	55	95,56	BC831080	159,01
BC840490	4,90	6	66	28	47,22	BC830490	83,63	BC841100	11,0	12	102	55	95,56	BC831100	159,01
BC840500	5,00	6	66	28	47,22	BC830500	83,63	BC841110	11,1	12	102	55	95,56	BC831110	159,01
BC840520	5,20	6	66	28	47,22	BC830520	83,63	BC841120	11,2	12	102	55	95,56	BC831120	159,01
BC840550	5,50	6	66	28	47,22	BC830550	83,63	BC841130	11,3	12	102	55	95,56	BC831130	159,01
BC840560	5,60	6	66	28	47,22	BC830560	83,63	BC841150	11,5	12	102	55	95,56	BC831150	159,01
BC840570	5,70	6	66	28	47,22	BC830570	83,63	BC841170	11,7	12	102	55	95,56	BC831170	159,01
BC840580	5,80	6	66	28	47,22	BC830580	83,63	BC841180	11,8	12	102	55	95,56	BC831180	159,01
BC840590	5,90	6	66	28	47,22	BC830590	83,63	BC841200	12,0	12	102	55	95,56	BC831200	159,01
BC840600	6,00	6	66	28	47,22	BC830600	83,63	BC841210	12,1	14	107	60	127,42	BC831210	221,24
BC840610	6,10	8	79	34	55,29	BC830610	99,33	BC841230	12,3	14	107	60	127,42	BC831230	221,24
BC840620	6,20	8	79	34	55,29	BC830620	99,33	BC841240	12,4	14	107	60	127,42	BC831240	221,24
BC840630	6,30	8	79	34	55,29	BC830630	99,33	BC841250	12,5	14	107	60	127,42	BC831250	221,24
BC840650	6,50	8	79	34	55,29	BC830650	99,33	BC841270	12,7	14	107	60	127,42	BC831270	221,24
BC840660	6,60	8	79	34	55,29	BC830660	99,33	BC841280	12,8	14	107	60	127,42	BC831280	221,24
BC840670	6,70	8	79	34	55,29	BC830670	99,33	BC841300	13,0	14	107	60	127,42	BC831300	221,24
BC840680	6,80	8	79	34	55,29	BC830680	99,33	BC841310	13,1	14	107	60	127,42	BC831310	221,24
BC840690	6,90	8	79	34	55,29	BC830690	99,33	BC841330	13,3	14	107	60	127,42	BC831330	221,24
BC840700	7,00	8	79	34	55,29	BC830700	99,33	BC841350	13,5	14	107	60	127,42	BC831350	221,24
BC840710	7,10	8	79	41	55,29	BC830710	99,33	BC841370	13,7	14	107	60	127,42	BC831370	221,24
BC840740	7,40	8	79	41	55,29	BC830740	99,33	BC841380	13,8	14	107	60	127,42	BC831380	221,24
BC840750	7,50	8	79	41	55,29	BC830750	99,33	BC841400	14,0	14	107	60	127,42	BC831400	221,24
BC840780	7,80	8	79	41	55,29	BC830780	99,33	BC841450	14,5	16	115	65	159,55	BC831450	273,80
BC840790	7,90	8	79	41	55,29	BC830790	99,33	BC841470	14,7	16	115	65	159,55	BC831470	273,80
BC840800	8,00	8	79	41	55,29	BC830800	99,33	BC841480	14,8	16	115	65	159,55	BC831480	273,80
BC840810	8,10	10	89	47	63,72	BC830810	111,26	BC841500	15,0	16	115	65	159,55	BC831500	273,80
BC840820	8,20	10	89	47	63,72	BC830820	111,26	BC841550	15,5	16	115	65	159,55	BC831550	273,80
BC840830	8,30	10	89	47	63,72	BC830830	111,26	BC841600	16,0	16	115	65	159,55	BC831600	273,80
BC840840	8,40	10	89	47	63,72	BC830840	111,26	BC841650	16,5	18	123	73	243,90	BC831650	431,72
BC840850	8,50	10	89	47	63,72	BC830850	111,26	BC841700	17,0	18	123	73	243,90	BC831700	431,72
BC840860	8,60	10	89	47	63,72	BC830860	111,26	BC841750	17,5	18	123	73	243,90	BC831750	431,72
BC840870	8,70	10	89	47	63,72	BC830870	111,26	BC841800	18,0	18	123	73	243,90	BC831800	431,72
BC840880	8,80	10	89	47	63,72	BC830880	111,26	BC841850	18,5	20	131	79	297,79	BC831850	474,42
BC840890	8,90	10	89	47	63,72	BC830890	111,26	BC841900	19,0	20	131	79	297,79	BC831900	474,42
BC840900	9,00	10	89	47	63,72	BC830900	111,26	BC841950	19,5	20	131	79	297,79	BC831950	474,42
BC840910	9,10	10	89	47	63,72	BC830910	111,26	BC842000	20,0	20	131	79	297,79	BC832000	474,42
BC840930	9,30	10	89	47	63,72	BC830930	111,26								



Forets pour métaux

Rose

FORETS CARBURE DIN 6537L AVEC OU SANS TROUS D'HUILE

 Réf. BC97
 Réf. BC89

5xD
**DIN
6537L**
CARBURE
**TOL D1
m7**
**TOL D2
h6**

TiAIN
**HARDOX
450**
**HAUTE
PERFORMANCE**

Foret spécial pour HARDOX 450



BC97

BC89

BC97						BC89		BC97						BC89	
	D1 mm	D2 mm	L1 mm	L2 mm	€		€		D1 mm	D2 mm	L1 mm	L2 mm	€		€
BC970300	3,0	6	66	28	57,57	BC890300	99,24	BC970900	9,0	10	103	61	81,94	BC890900	129,27
BC970310	3,1	6	66	28	57,57	BC890310	99,24	BC970910	9,1	10	103	61	81,94	BC890910	129,27
BC970320	3,2	6	66	28	57,57	BC890320	99,24	BC970920	9,2	10	103	61	81,94	BC890920	129,27
BC970340	3,4	6	66	28	57,57	BC890340	99,24	BC970930	9,3	10	103	61	81,94	BC890930	129,27
BC970350	3,5	6	66	28	57,57	BC890350	99,24	BC970940	9,4	10	103	61	81,94	BC890940	129,27
BC970360	3,6	6	66	28	57,57	BC890360	99,24	BC970950	9,5	10	103	61	81,94	BC890950	129,27
BC970380	3,8	6	74	36	57,57	BC890380	99,24	BC970960	9,6	10	103	61	81,94	BC890960	129,27
BC970390	3,9	6	74	36	57,57	BC890390	99,24	BC970970	9,7	10	103	61	81,94	BC890970	129,27
BC970400	4,0	6	74	36	57,57	BC890400	99,24	BC970980	9,8	10	103	61	81,94	BC890980	129,27
BC970420	4,2	6	74	36	57,57	BC890420	99,24	BC970990	9,9	10	103	61	81,94	BC890990	129,27
BC970440	4,4	6	74	36	57,57	BC890440	99,24	BC971000	10,0	10	103	61	81,94	BC891000	129,27
BC970450	4,5	6	74	36	57,57	BC890450	99,24	BC971010	10,1	12	118	71	117,96	BC891010	184,03
BC970460	4,6	6	74	36	57,57	BC890460	99,24	BC971020	10,2	12	118	71	117,96	BC891020	184,03
BC970470	4,7	6	74	36	57,57	BC890470	99,24	BC971040	10,4	12	118	71	117,96	BC891040	184,03
BC970480	4,8	6	82	44	57,57	BC890480	99,24	BC971050	10,5	12	118	71	117,96	BC891050	184,03
BC970490	4,9	6	82	44	57,57	BC890490	99,24	BC971060	10,6	12	118	71	117,96	BC891060	184,03
BC970500	5,0	6	82	44	57,57	BC890500	99,24	BC971070	10,7	12	118	71	117,96	BC891070	184,03
BC970520	5,2	6	82	44	57,57	BC890520	99,24	BC971080	10,8	12	118	71	117,96	BC891080	184,03
BC970530	5,3	6	82	44	57,57	BC890530	99,24	BC971100	11,0	12	118	71	117,96	BC891100	184,03
BC970540	5,4	6	82	44	57,57	BC890540	99,24	BC971110	11,1	12	118	71	117,96	BC891110	184,03
BC970550	5,5	6	82	44	57,57	BC890550	99,24	BC971120	11,2	12	118	71	117,96	BC891120	184,03
BC970560	5,6	6	82	44	57,57	BC890560	99,24	BC971130	11,3	12	118	71	117,96	BC891130	184,03
BC970570	5,7	6	82	44	57,57	BC890570	99,24	BC971140	11,4	12	118	71	117,96	BC891140	184,03
BC970580	5,8	6	82	44	57,57	BC890580	99,24	BC971150	11,5	12	118	71	117,96	BC891150	184,03
BC970590	5,9	6	82	44	57,57	BC890590	99,24	BC971160	11,5	12	118	71	117,96	BC891160	184,03
BC970600	6,0	6	82	44	57,57	BC890600	99,24	BC971170	11,5	12	118	71	117,96	BC891170	184,03
BC970610	6,1	8	91	53	63,06	BC890610	111,20	BC971180	11,8	12	118	71	117,96	BC891180	184,03
BC970620	6,2	8	91	53	63,06	BC890620	111,20	BC971200	12,0	12	118	71	117,96	BC891200	184,03
BC970630	6,3	8	91	53	63,06	BC890630	111,20	BC971210	12,1	14	124	77	155,06	BC891210	249,96
BC970640	6,4	8	91	53	63,06	BC890640	111,20	BC971230	12,3	14	124	77	155,06	BC891230	249,96
BC970650	6,5	8	91	53	63,06	BC890650	111,20	BC971240	12,4	14	124	77	155,06	BC891240	249,96
BC970660	6,6	8	91	53	63,06	BC890660	111,20	BC971250	12,5	14	124	77	155,06	BC891250	249,96
BC970670	6,7	8	91	53	63,06	BC890670	111,20	BC971270	12,7	14	124	77	155,06	BC891270	249,96
BC970680	6,8	8	91	53	63,06	BC890680	111,20	BC971300	13,0	14	124	77	155,06	BC891300	249,96
BC970690	6,9	8	91	53	63,06	BC890690	111,20	BC971310	13,1	14	124	77	155,06	BC891310	249,96
BC970700	7,0	8	91	53	63,06	BC890700	111,20	BC971330	13,3	14	124	77	155,06	BC891330	249,96
BC970710	7,1	8	91	53	63,06	BC890710	111,20	BC971350	13,5	14	124	77	155,06	BC891350	249,96
BC970720	7,2	8	91	53	63,06	BC890720	111,20	BC971370	13,7	14	124	77	155,06	BC891370	249,96
BC970730	7,3	8	91	53	63,06	BC890730	111,20	BC971380	13,8	14	124	77	155,06	BC891380	249,96
BC970740	7,4	8	91	53	63,06	BC890740	111,20	BC971400	14,0	14	124	77	155,06	BC891400	249,96
BC970750	7,5	8	91	53	63,06	BC890750	111,20	BC971450	14,5	16	133	83	194,37	BC891450	313,48
BC970760	7,6	8	91	53	63,06	BC890760	111,20	BC971470	14,7	16	133	83	194,37	BC891470	313,48
BC970770	7,7	8	91	53	63,06	BC890770	111,20	BC971480	14,8	16	133	83	194,37	BC891480	313,48
BC970780	7,8	8	91	53	63,06	BC890780	111,20	BC971500	15,0	16	133	83	194,37	BC891500	313,48
BC970790	7,9	8	91	53	63,06	BC890790	111,20	BC971550	15,5	16	133	83	194,37	BC891550	313,48
BC970800	8,0	8	91	53	63,06	BC890800	111,20	BC971580	15,8	16	133	83	194,37	BC891580	313,48
BC970810	8,1	10	103	61	81,94	BC890810	129,27	BC971600	16,0	16	133	83	194,37	BC891600	313,48
BC970830	8,3	10	103	61	81,94	BC890830	129,27	BC971650	16,5	18	143	93	323,79	BC891650	494,93
BC970840	8,4	10	103	61	81,94	BC890840	129,27	BC971700	17,0	18	143	93	323,79	BC891700	494,93
BC970850	8,5	10	103	61	81,94	BC890850	129,27	BC971750	17,5	18	143	93	323,79	BC891750	494,93
BC970860	8,6	10	103	61	81,94	BC890860	129,27	BC971800	18,0	18	143	93	323,79	BC891800	494,93
BC970870	8,7	10	103	61	81,94	BC890870	129,27	BC971850	18,5	20	153	101	353,91	BC891850	540,98
BC970880	8,8	10	103	61	81,94	BC890880	129,27	BC971900	19,0	20	153	101	353,91	BC891900	540,98
BC970890	8,9	10	103	61	81,94	BC890890	129,27	BC971950	19,5	20	153	101	353,91	BC891950	540,98
								BC972000	20,0	20	153	101	353,91	BC892000	540,98

FORETS CARBURE DIN 6537L AVEC TROUS D'HUILE

Réf. BC96

7xD

CARBURE

**TOL D1
m7**

**TOL D2
h6**



TiAIN

**HARDOX
450**

**HAUTE
PERFORMANCE**

Foret spécial pour HARDOX 450

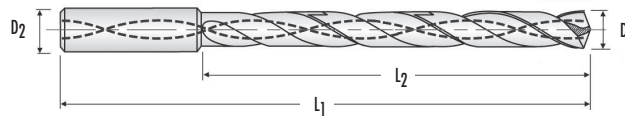

	BC96				
	D1 mm	D2 mm	L1 mm	L2 mm	€
BC960300	3,00	6	72	34	178,81
BC960320	3,20	6	72	34	178,81
BC960350	3,50	6	72	34	178,81
BC960380	3,80	6	81	43	178,81
BC960400	4,00	6	81	43	178,81
BC960420	4,20	6	81	43	178,81
BC960450	4,50	6	81	43	178,81
BC960480	4,80	6	95	57	178,81
BC960500	5,00	6	95	57	178,81
BC960520	5,20	6	95	57	178,81
BC960550	5,50	6	95	57	178,81
BC960560	5,60	6	95	57	178,81
BC960570	5,70	6	95	57	178,81
BC960580	5,80	6	95	57	178,81
BC960590	5,90	6	95	57	178,81
BC960600	6,00	6	95	57	178,81
BC960610	6,10	8	114	76	194,76
BC960620	6,20	8	114	76	194,76
BC960630	6,30	8	114	76	194,76
BC960650	6,50	8	114	76	194,76
BC960660	6,60	8	114	76	194,76
BC960680	6,80	8	114	76	194,76
BC960690	6,90	8	114	76	194,76
BC960700	7,00	8	114	76	194,76
BC960710	7,10	8	114	76	194,76
BC960740	7,40	8	114	76	194,76
BC960750	7,50	8	114	76	194,76
BC960780	7,80	8	114	76	194,76
BC960800	8,00	8	114	76	194,76
BC960810	8,10	10	142	95	263,73
BC960840	8,40	10	142	95	263,73
BC960850	8,50	10	142	95	263,73
BC960860	8,60	10	142	95	263,73
BC960870	8,70	10	142	95	263,73
BC960880	8,80	10	142	95	263,73
BC960900	9,00	10	131	87	263,73
BC960930	9,30	10	142	95	263,73
BC960950	9,50	10	142	95	263,73
BC960960	9,60	10	142	95	263,73
BC960980	9,80	10	142	95	263,73
BC961000	10,00	10	142	95	263,73
BC961020	10,20	12	162	114	347,71
BC961040	10,40	12	162	114	347,71
BC961050	10,50	12	162	114	347,71
BC961060	10,60	12	162	114	347,71
BC961080	10,80	12	162	114	347,71
BC961100	11,00	12	162	114	347,71
BC961120	11,20	12	162	114	347,71
BC961150	11,50	12	162	114	347,71
BC961180	11,80	12	162	114	347,71
BC961200	12,00	12	162	114	347,71



FORETS CARBURE DIN 6537L AVEC TROUS D'HUILE

Réf. BXX

12xD
**DIN
6537L**
CARBURE
**TOL D1
m7**
**TOL D2
h6**

TiAIN
**HARDOX
450**
**HAUTE
PERFORMANCE**

Foret spécial pour HARDOX 450

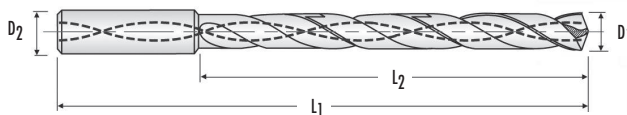

BXX					
	D1 mm	D2 mm	L1 mm	L2 mm	€
BXX0300	3,0	6	92	54	206,07
BXX0320	3,2	6	92	54	206,07
BXX0330	3,3	6	92	54	206,07
BXX0350	3,5	6	92	54	206,07
BXX0370	3,7	6	92	54	206,07
BXX0380	3,8	6	102	64	206,07
BXX0390	3,9	6	102	64	206,07
BXX0400	4,0	6	102	64	206,07
BXX0420	4,2	6	102	64	206,07
BXX0430	4,3	6	102	64	206,07
BXX0440	4,4	6	102	64	219,84
BXX0450	4,5	6	102	64	219,84
BXX0460	4,6	6	102	64	219,84
BXX0470	4,7	6	102	64	219,84
BXX0480	4,8	6	116	78	219,84
BXX0490	4,9	6	116	78	219,84
BXX0500	5,0	6	116	78	219,84
BXX0510	5,1	6	116	78	219,84
BXX0520	5,2	6	116	78	219,84
BXX0530	5,3	6	116	78	219,84
BXX0540	5,4	6	116	78	219,84
BXX0550	5,5	6	116	78	219,84
BXX0560	5,6	6	116	78	219,84
BXX0570	5,7	6	116	78	219,84
BXX0580	5,8	6	116	78	219,84
BXX0590	5,9	6	116	78	219,84
BXX0600	6,0	6	116	78	219,84
BXX0610	6,1	8	146	108	269,31
BXX0620	6,2	8	146	108	269,31
BXX0650	6,5	8	146	108	269,31
BXX0660	6,6	8	146	108	269,31
BXX0670	6,7	8	146	108	269,31
BXX0680	6,8	8	146	108	285,77
BXX0690	6,9	8	146	108	285,77
BXX0700	7,0	8	146	108	285,77

BXX					
	D1 mm	D2 mm	L1 mm	L2 mm	€
BXX0740	7,4	8	146	108	285,77
BXX0750	7,5	8	146	108	285,77
BXX0770	7,7	8	146	108	285,77
BXX0780	7,8	8	146	108	315,42
BXX0800	8,0	8	146	108	319,57
BXX0820	8,2	10	162	120	357,27
BXX0850	8,5	10	162	120	357,27
BXX0880	8,8	10	162	120	357,27
BXX0900	9,0	10	162	120	357,27
BXX0950	9,5	10	162	120	357,27
BXX0980	9,8	10	162	120	357,27
BXX0990	9,9	10	162	120	357,27
BXX1000	10,0	10	162	120	357,27
BXX1010	10,1	12	204	156	500,16
BXX1020	10,2	12	204	156	500,16
BXX1030	10,3	12	204	156	500,16
BXX1050	10,5	12	204	156	500,16
BXX1080	10,8	12	204	156	500,16
BXX1100	11,0	12	204	156	500,16
BXX1120	11,2	12	204	156	500,16
BXX1140	11,4	12	204	156	500,16
BXX1150	11,5	12	204	156	500,16
BXX1180	11,8	12	204	156	500,16
BXX1200	12,0	12	204	156	500,16
BXX1250	12,5	14	230	182	654,03
BXX1280	12,8	14	230	182	654,03
BXX1300	13,0	14	230	182	654,03
BXX1350	13,5	14	230	182	654,03
BXX1380	13,8	14	230	182	654,03
BXX1400	14,0	14	230	182	654,03
BXX1450	14,5	16	260	208	851,85
BXX1500	15,0	16	260	208	851,85
BXX1550	15,5	16	260	208	851,85
BXX1600	16,0	16	260	208	851,85



FORETS CARBURE DIN 6537L AVEC TROUS D'HUILE

Réf. BXL
Réf. BXXL

**DIN
6537L**

CARBURE

**TOL D1
m7**

**TOL D2
h6**



TiAIN

**HARDOX
450**

**HAUTE
PERFORMANCE**

Foret spécial pour HARDOX 450

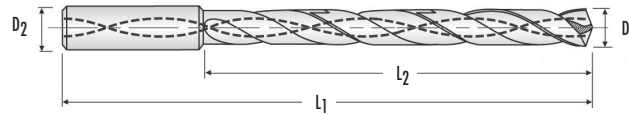

15xD

	D1 mm	D2 mm	L1 mm	L2 mm	BXL €
BXLO300	3,0	6	100	60	279,60
BXLO320	3,2	6	100	60	279,60
BXLO330	3,3	6	100	60	279,60
BXLO350	3,5	6	100	60	279,60
BXLO380	3,8	6	108	68	279,60
BXLO390	3,9	6	108	68	279,60
BXLO400	4,0	6	108	68	279,60
BXLO420	4,2	6	115	78	311,34
BXLO450	4,5	6	115	78	311,34
BXLO500	5,0	6	125	84	320,02
BXLO550	5,5	6	130	92	325,63
BXLO590	5,9	6	140	100	325,63
BXLO600	6,0	6	140	100	325,63
BXLO650	6,5	8	145	108	427,81
BXLO680	6,8	8	170	130	486,51
BXLO700	7,0	8	170	130	486,51
BXLO750	7,5	8	170	130	486,51
BXLO780	7,8	8	170	130	486,51
BXLO800	8,0	8	170	130	486,51
BXLO850	8,5	10	208	163	659,68
BXLO900	9,0	10	208	163	659,68
BXLO950	9,5	10	208	163	659,68
BXLO980	9,8	10	208	163	659,68
BXL1000	10,0	10	208	163	659,68
BXL1050	10,5	12	245	195	847,76
BXL1100	11,0	12	245	195	847,76
BXL1150	11,5	12	245	195	847,76
BXL1180	11,8	12	245	195	847,76
BXL1200	12,0	12	245	195	847,76
BXL1250	12,5	14	280	230	1.161,34
BXL1300	13,0	14	280	230	1.161,34
BXL1400	14,0	14	280	230	1.161,34
BXL1500	15,0	16	310	260	1.414,23

20xD

	D1 mm	D2 mm	L1 mm	L2 mm	BXXL €
BXXLO300	3,0	6	110	70	307,56
BXXLO350	3,5	6	136	96	307,56
BXXLO400	4,0	6	136	96	307,56
BXXLO450	4,5	6	158	118	342,47
BXXLO500	5,0	6	158	118	352,02
BXXLO510	5,1	6	180	140	358,19
BXXLO550	5,5	6	180	140	358,19
BXXLO600	6,0	6	180	140	358,19
BXXLO650	6,5	8	202	162	470,59
BXXLO700	7,0	8	202	162	535,16
BXXLO750	7,5	8	223	183	535,16
BXXLO800	8,0	8	223	183	535,16
BXXLO850	8,5	10	249	205	725,65
BXXLO900	9,0	10	249	205	725,65
BXXL1000	10,0	10	271	227	725,65



BXL

BXXL

FORETS MICROMÉTRIQUES À QUEUE RENFORCÉE

Réf. BC30

HSS



5xD

BC30				
	D ₁ mm	L ₁ mm	L ₂ mm	€
BC300050	0,50	43	5	3,37
BC300060	0,60	43	7	3,37
BC300070	0,70	43	7	3,37
BC300075	0,75	43	7	3,37
BC300080	0,80	43	7	3,37
BC300090	0,90	43	7	3,37
BC300095	0,95	43	7	3,37
BC300100	1,00	43	7	3,37
BC300110	1,10	43	7	3,37
BC300120	1,20	43	10	3,37
BC300125	1,25	43	10	3,37
BC300130	1,30	43	10	3,37

BC30				
	D ₁ mm	L ₁ mm	L ₂ mm	€
BC300140	1,40	43	10	3,37
BC300150	1,50	43	10	3,37
BC300160	1,60	43	10	3,37
BC300170	1,70	43	10	3,37
BC300175	1,75	43	10	3,37
BC300180	1,80	43	10	3,37
BC300190	1,90	43	10	3,37
BC300200	2,00	43	10	3,37
BC300210	2,10	43	10	3,37
BC300220	2,20	43	10	3,37
BC300225	2,25	43	10	3,37
BC300235	2,35	43	10	3,37
BC300240	2,40	43	10	3,37



Réf. BC79

CARBURE



5xD

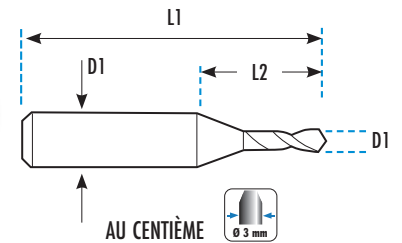

BC79				
	D ₁ mm	L ₁ mm	L ₂ mm	€
BC790025	0,25	38	5	28,84
BC790030	0,30	38	5	28,84
BC790035	0,35	38	5	28,84
BC790040	0,40	38	5	20,96
BC790045	0,45	38	5	20,96
BC790050	0,50	38	5	14,55
BC790055	0,55	38	5	14,55
BC790060	0,60	38	5	14,55
BC790065	0,65	38	5	13,13
BC790070	0,70	38	10	13,13
BC790075	0,75	38	10	13,13
BC790080	0,80	38	10	13,13
BC790085	0,85	38	10	13,13
BC790090	0,90	38	10	13,13
BC790095	0,95	38	10	13,13
BC790100	1,00	38	10	13,13
BC790105	1,05	38	10	13,13
BC790110	1,10	38	10	13,13
BC790115	1,15	38	10	13,13
BC790120	1,20	38	10	13,13
BC790125	1,25	38	10	13,13
BC790130	1,30	38	10	13,13
BC790135	1,35	38	10	13,13
BC790140	1,40	38	10	13,13
BC790145	1,45	38	10	13,13
BC790150	1,50	38	10	13,13
BC790155	1,55	38	10	13,13
BC790160	1,60	38	10	13,13
BC790165	1,65	38	10	16,51
BC790170	1,70	38	10	16,51

BC79				
	D ₁ mm	L ₁ mm	L ₂ mm	€
BC790175	1,75	38	10	16,51
BC790180	1,80	38	10	16,51
BC790185	1,85	38	10	16,51
BC790190	1,90	38	10	16,51
BC790195	1,95	38	10	16,51
BC790200	2,00	38	10	16,51
BC790205	2,05	38	10	16,51
BC790210	2,10	38	10	16,51
BC790215	2,15	38	10	16,51
BC790220	2,20	38	10	16,51
BC790225	2,25	38	10	16,51
BC790230	2,30	38	10	16,51
BC790235	2,35	38	10	16,51
BC790240	2,40	38	10	16,51
BC790245	2,45	38	10	16,51
BC790250	2,50	38	10	16,51
BC790255	2,55	38	10	16,51
BC790260	2,60	38	10	16,51
BC790265	2,65	38	10	16,51
BC790270	2,70	38	10	16,51
BC790275	2,75	38	10	16,51
BC790280	2,80	38	10	16,51
BC790285	2,85	38	10	16,51
BC790290	2,90	38	10	16,51
BC790295	2,95	38	10	16,51
BC790300	3,00	38	10	16,51
BC790305	3,05	38	10	16,51
BC790310	3,10	38	10	16,51
BC790315	3,15	38	10	16,51

BC79	
D ₁ mm	€
0,10 - 0,39	28,84
0,41 - 0,89	21,51
0,91 - 1,19	21,51
1,21 - 1,39	23,22
1,41 - 1,89	23,22
1,91 - 2,19	23,22
2,21 - 2,39	24,20
2,41 - 2,89	24,20
2,91 - 2,99	24,20



FORET CARBURE POUR ACIERS TRAITÉS ET POUR BLINDAGES

Ref. BC85

**70
HRC**

CARBURE

**TOL D1
h7**

**TOL D2
h6**



TiAIN

**HARDOX
600**



Foret spécial pour HARDOX 600

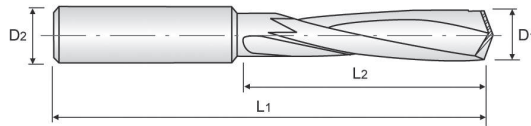

	BC85				
	D1 mm	D2 mm	L1 mm	L2 mm	€
BC850300	3,0	3	46	16	47,42
BC850330	3,3	4	48	18	54,43
BC850340	3,4	4	50	20	54,43
BC850350	3,5	4	50	20	54,43
BC850400	4,0	4	52	22	55,53
BC850420	4,2	6	65	25	78,85
BC850430	4,3	6	68	28	78,85
BC850440	4,4	6	68	28	78,85
BC850450	4,5	6	68	28	78,85
BC850500	5,0	6	72	32	78,85
BC850510	5,1	6	72	32	78,85
BC850520	5,2	6	72	32	78,85
BC850550	5,5	6	75	35	78,85
BC850600	6,0	6	75	35	78,85
BC850630	6,3	8	80	40	97,80*
BC850650	6,5	8	80	40	97,80
BC850680	6,8	8	85	45	97,80
BC850690	6,9	8	85	45	97,80
BC850700	7,0	8	85	45	97,80
BC850750	7,5	8	85	45	97,80
BC850800	8,0	8	98	50	97,80
BC850850	8,5	10	98	50	149,47
BC850860	8,6	10	105	57	149,47
BC850880	8,8	10	105	57	149,47
BC850900	9,0	10	105	57	149,47
BC850950	9,5	10	105	57	149,47
BC851000	10,0	10	111	63	149,47
BC851020	10,2	12	111	63	193,57
BC851030	10,3	12	111	63	227,13
BC851040	10,4	12	111	63	227,13
BC851050	10,5	12	111	63	227,13
BC851080	10,8	12	119	71	227,13
BC851100	11,0	12	119	71	227,13
BC851150	11,5	12	119	71	227,13
BC851200	12,0	12	119	71	227,13
BC851400	14,0	14	125	77	258,10

*Jusqu'à fin de stock

PERÇAGE DE TARAUDS/VIS CASSÉS

Vis cassée

Étape 1
Nettoyer la surface

Étape 2
Perçer avec le foret BC85

Étape 3
Nettoyer les copeaux

Étape 4 (Optionnel)
Réparer le filetage avec
le filet rapporté

FORET STEP CUT POUR PERÇAGE DE SURFACES COURBES ET INSTABLES
**DIN
338**
HSS

Al

Réf. TK02

Forets pour métaux

Rose

STEP CUT

Foret hélicoïdal HSS avec géométrie de la pointe STEP CUT, coupe étagée.

NOUVEAU Foret STEP CUT: Géométrie étagée pour une pénétration progressive.

Pour travailler facilement, rapidement et précisément sur des surfaces courbes, instables ou inclinées.

Précision accrue grâce à la pointe de centrage qui empêche le glissement au début du perçage.

La géométrie STEP CUT À COUPE ÉTAGÉE crée des trous plus centrés, plus ronds et plus précis.

Le triple méplat ANTI-GLISSE sur la queue transmet la puissance de la perceuse de manière efficace.

Permet de percer l'acier, l'aluminium, le cuivre, le nickel, le zinc, le PVC, la fibre de verre et le bois.

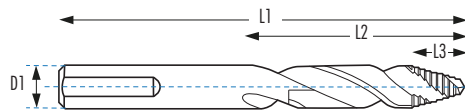

	TK02					
	D1 mm	L1 mm	L2 mm	L3 mm		€
TK020100	1,0	34	12	-	10	3,42
TK020150	1,5	40	18	-	10	3,52
TK020200	2,0	49	24	-	10	3,67
TK020250	2,5	57	30	1,6	10	4,27
TK020300	3,0	61	33	1,9	10	4,48
TK020320	3,2	65	36	2,1	10	5,36
TK020330	3,3	65	36	2,2	10	5,36
TK020350	3,5	70	39	2,1	10	5,36
TK020400	4,0	75	43	2,9	10	6,34
TK020410	4,1	75	43	3,0	10	6,97
TK020420	4,2	75	43	3,0	10	6,97
TK020450	4,5	80	47	3,3	10	6,97
TK020490	4,9	76	52	3,8	10	7,87
TK020500	5,0	76	52	3,9	10	7,87
TK020510	5,1	76	52	4,0	10	8,33
TK020520	5,2	76	52	4,2	10	8,33
TK020550	5,5	93	57	4,6	10	8,33
TK020600	6,0	93	57	5,3	10	9,08
TK020650	6,5	101	63	5,8	10	10,59
TK020680	6,8	109	69	5,9	10	12,11
TK020700	7,0	109	69	6,4	10	12,11
TK020750	7,5	109	69	6,9	10	14,16
TK020800	8,0	117	75	7,6	10	14,63
TK020850	8,5	117	75	8,2	10	17,36
TK020900	9,0	125	81	8,8	10	19,17
TK020950	9,5	125	81	9,3	10	20,68
TK021000	10,0	133	87	10,0	10	22,05
TK021020	10,2	133	87	9,9	10	24,02
TK021050	10,5	133	87	10,7	10	24,02
TK021100	11,0	142	94	11,3	6	26,52
TK021150	11,5	142	94	12,0	6	28,85
TK021200	12,0	151	101	12,6	6	31,48
TK021250	12,5	151	101	13,8	6	33,50
TK021300	13,0	151	101	14,7	6	36,11



FORET STEP CUT POUR PERÇAGE DE SURFACES COURBES ET INSTABLES

Ref. TK05

DIN 338

HSSCo 5%



INOX





FONTE

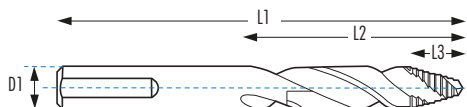

STEP CUT

Foret Hélicoïdal HSSCo 5% à rendement élevé STEP CUT, coupe étagée.
 Nouveau Foret STEP CUT: Géométrie étagée pour une pénétration progressive.
 Pour travailler facilement, rapidement et précisément sur des surfaces courbes, instables ou inclinées.
 Précision accrue grâce à la pointe de centrage qui empêche le glissement au début du perçage.
 La géométrie STEP CUT à coupe étagée crée des trous plus centrés, plus ronds et plus précis.
 Le triple méplat ANTI-GLISSE sur la queue transmet la puissance de la perceuse de manière efficace.
 Permet de percer l'acier inoxydable, la fonte, le cuivre, le nickel, le zinc, le PVC et la fibre de verre.



	D1 mm	L1 mm	L2 mm	L3 mm		TK05 €
TK050100	1,0	34	12	-	10	4,61
TK050150	1,5	40	18	-	10	4,76
TK050200	2,0	49	24	-	10	4,95
TK050250	2,5	57	30	1,6	10	5,77
TK050300	3,0	61	33	1,9	10	6,06
TK050350	3,5	70	39	2,1	10	7,23
TK050400	4,0	75	43	2,9	10	8,57
TK050450	4,5	80	47	3,3	10	9,41
TK050500	5,0	76	52	3,9	10	10,62
TK050550	5,5	93	57	4,6	10	11,25
TK050600	6,0	93	57	5,3	10	11,35
TK050650	6,5	101	63	5,8	10	13,24
TK050700	7,0	109	69	6,4	10	15,14
TK050750	7,5	109	69	6,9	10	17,71
TK050800	8,0	117	75	7,6	10	18,28
TK050850	8,5	117	75	8,2	10	21,70
TK050900	9,0	125	81	8,8	10	23,96
TK050950	9,5	125	81	9,3	10	25,85
TK051000	10,0	133	87	10,0	10	25,36
TK051050	10,5	133	87	10,7	10	27,61
TK051100	11,0	142	94	11,3	6	30,51
TK051150	11,5	142	94	12,0	6	33,18
TK051200	12,0	151	101	12,6	6	36,19
TK051250	12,5	151	101	13,8	6	38,51
TK051300	13,0	151	101	14,7	6	41,53



OUTILS STEP CUT POUR PERÇAGE DE SURFACES COURBES ET INSTABLES

Forets pour métaux

NEW

HSS

FORETS MICRO-ÉTAGÉS STEP CUT

 NEW
STEP CUT

HAUTEUR ÉTAGE 2 mm

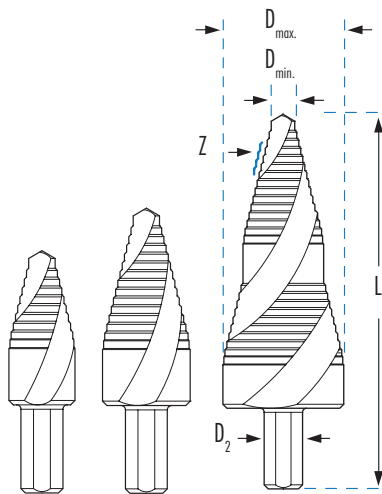

AV40BM37



AV40BM38



AV40BM36

							AV40BM
	D min. mm	D max. mm	D2 mm	L1 mm	Z	Ø Z mm min - max	HSS €
AV40BM37B	6,0	15,0	9,5	55	11	6-7-8-9-10-11-12-13-14-14,5-15	27,75
AV40BM38B	6,0	20,0	9,5	65	16	6-7-8-9-10-11-12-13-14-15-16-17-18-19-19,5-20	41,49
AV40BM36B	6,0	30,0	9,5	93	27	6-7-8-9-10-11-12-13-14-15-16-17-18-19-19,5-20-21-22-23-24-25-26-27-28-29-29,5-30	102,31

FORET-TARAUD HSSCo STEP CUT

NEW

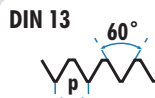

DIN 13

HSSCo
5%

BRILLANT

TOL
6HD
QUEUE
DÉGAGÉE

STEP CUT

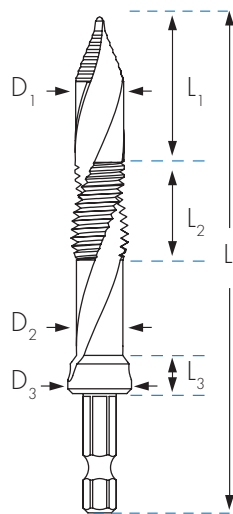

									MTKM	
			L1 mm	L2 mm	L3 mm	L mm	D1 mm	D2 mm	D3 mm	€
M	3x0,50	D	7,5	6,0	6,0	52,0	2,5	2,2	7,3	20,27
M	4x0,70	D	10,0	8,4	6,0	56,4	3,3	3,0	7,3	20,27
M	5x0,80	D	13,0	9,5	6,0	63,5	4,2	3,7	7,3	20,27
M	6x1,00	D	15,0	12,0	6,0	68,0	5,0	4,5	7,3	20,27
M	8x1,25	D	20,0	15,0	6,0	81,0	6,8	6,3	9,4	28,04
M	10x1,50	D	25,0	18,0	6,0	89,0	8,5	8,0	11,4	33,81
M	12x1,75	D	30,0	21,0	8,0	104,0	10,3	9,8	13,4	56,36

FORET CARBURE POUR LE PERÇAGE DES CYLINDRES

Réf. BCC06

CARBURE

30° 30° 0°

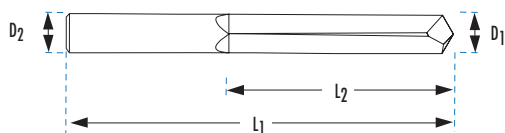

* Apte pour le perçage des goupilles "anti-drilling" de tout cylindre.

					BCC06
	D ₁ mm	D ₂ mm	L ₂ mm	L ₁ mm	€
BCC06X60MD	6	6	33	60	49,56

* Pour le perçage de cylindres avec des goupilles anti-drilling, travailler à 300 RPM

FORET POUR ENVIRONNEMENT ATEX

Réf. BACH

22 HRC

Cu-Be

118° 30° "N"

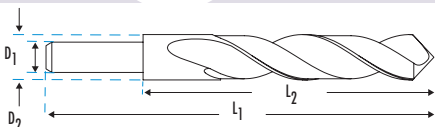

* Fabriqué en Cuivre-Béryllium, conformément au standard Q/ZBF-312.
* Certificats et fiches de sécurité disponibles.
* Apte pour travailler en atmosphères explosibles.

					BACH
	D ₁ mm	D ₂ mm	L ₁ mm	L ₂ mm	€
BACH0600	6,0	6,0	100	60	475,85
BACH0700	7,0	7,0	120	80	495,62
BACH0800	8,0	8,0	140	80	526,13
BACH0900	9,0	9,0	160	86	548,57
BACH1000	10,0	10,0	180	108	579,11
BACH1100	11,0	11,0	200	125	598,86
BACH1200	12,0	12,0	220	135	618,61
BACH1300	13,0	12,0	240	150	641,96
BACH1400	14,0	12,0	260	160	661,70
BACH1500	15,0	12,0	280	190	681,45
BACH1600	16,0	12,0	300	195	725,46
BACH1700	17,0	12,0	300	195	760,46
BACH1800	18,0	12,0	320	195	827,80
BACH1900	19,0	12,0	320	205	860,13
BACH2000	20,0	12,0	330	205	908,61

* Spéciaux sur demande

De par ses caractéristiques de dureté et résistance (sensiblement inférieures à celles obtenues pour des outils en acier), les outils ATEX ne peuvent être garantis contre les déformations et les casses.

Ne seront remplacés sous garantie que les outils dont la dureté est inférieure à 35HRC.



FORET DELTABIT 3 TAILLES
3Z

Réf. BTT33

**DIN
338**
**HSSCo
5%**

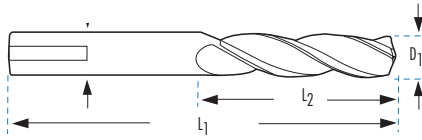
**TOL
H8**

- Plus grande précision du trou
- Orifices plus ronds et alignés
- Queue triple méplat anti-glisse, plus grande adhérence au mandrin

BTT33

	D1 mm	L1 mm	L2 mm	€
BTT330300	3,0	61	33	2,63
BTT330330	3,3	65	36	3,40
BTT330350	3,5	70	39	3,40
BTT330400	4,0	75	43	3,99
BTT330420	4,2	75	43	4,92
BTT330450	4,5	80	47	4,92
BTT330500	5,0	86	52	5,63
BTT330550	5,5	93	57	6,98
BTT330600	6,0	93	57	8,06
BTT330650	6,5	101	63	9,27
BTT330680	6,8	109	69	10,67
BTT330700	7,0	109	69	10,67
BTT330750	7,5	109	69	12,17
BTT330800	8,0	117	75	14,55
BTT330850	8,5	117	75	16,19
BTT330900	9,0	125	81	18,78
BTT330950	9,5	125	81	20,45
BTT331000	10,0	133	87	23,04
BTT331020	10,2	133	87	25,66
BTT331050	10,5	133	87	25,66
BTT331100	11,0	142	94	29,54
BTT331150	11,5	142	94	31,95
BTT331200	12,0	151	101	36,96
BTT331250	12,5	151	101	39,54
BTT331300	13,0	151	101	42,15



FORET SPÉCIAL PERÇAGE HARDOX ET TÔLE ANTI-USURE

Réf. BHA

3xD

**DIN
338**

**HSSCo
8%**



135°

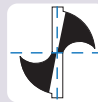

HARDTOP

**HARDOX
400**

**HARDOX
450**

**HARDOX
600**

Géométrie spéciale de la pointe avec affûtage en croix et double facette de détalonnage.
Le revêtement HARDTOP améliore l'évacuation des copeaux et évite leur adhérence à l'arête de coupe.
Améliore la résistance mécanique et protège le foret en réduisant le coefficient de friction.
Sa faible profondeur de goujure génère une âme renforcée qui facilite la stabilité de l'usinage.
Performance maximale dans les matériaux à haute résistance.

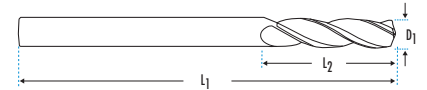

	BHA			
	D1 mm	L1 mm	L2 mm	€
BHA0100	1,0	34	6	12,02
BHA0150	1,5	40	9	12,02
BHA0200	2,0	49	12	12,49
BHA0250	2,5	57	14	12,73
BHA0300	3,0	61	16	12,84
BHA0320	3,2	65	18	13,67
BHA0330	3,3	65	18	13,67
BHA0350	3,5	70	20	13,67
BHA0400	4,0	75	22	14,52
BHA0420	4,2	75	22	18,93
BHA0450	4,5	80	24	18,93
BHA0500	5,0	86	26	17,94
BHA0550	5,5	93	28	24,24
BHA0600	6,0	93	28	22,71
BHA0650	6,5	101	31	26,18
BHA0680	6,8	109	34	30,41
BHA0700	7,0	109	34	28,03
BHA0750	7,5	109	34	33,57
BHA0800	8,0	117	37	36,50
BHA0850	8,5	117	37	36,50
BHA0900	9,0	125	40	43,70
BHA0950	9,5	125	40	49,33
BHA1000	10,0	133	43	47,85
BHA1020	10,2	133	43	55,67
BHA1050	10,5	133	43	60,13
BHA1100	11,0	142	47	62,57
BHA1150	11,5	142	47	70,45
BHA1200	12,0	151	51	65,62
BHA1250	12,5	151	51	86,20
BHA1300	13,0	151	51	93,94



Angle de la pointe 135°.
Excellent centrage.

BISEAU DE CENTRAGE ÉTROIT
Réduction totale de la friction
en dehors de la zone de coupe.

HARDTOP

Améliore l'évacuation des copeaux en diminuant le frottement le long de la goujure.

**HSSCo
8%**

ACIER M42 HSSCo 8%
Permet de travailler des matières de haute résistance et dureté à température élevée.

Norme dimensionnelle DIN 338.

	BHA			
vc (m/min)	Hardox® HiTuf	Hardox® 400	Hardox® 450	Hardox® 600
Ø	f(mm/rev.)	f(mm/rev.)	f(mm/rev.)	f(mm/rev.)
2,5	0,035/1400	0,025/1000	0,015/770	0,005/500
3	0,04/1200	0,03/850	0,02/640	0,01/430
4	0,05/900	0,04/650	0,03/480	0,02/320
5	0,06/700	0,05/510	0,04/400	0,03/255
6	0,07/590	0,06/430	0,05/320	0,04/220
7	0,08/500	0,07/370	0,06/280	0,05/190
8	0,09/440	0,08/320	0,07/240	0,06/160
10	0,11/350	0,10/260	0,09/200	0,08/130
13	0,14/270	0,13/200	0,12/150	0,1/100

FORETS CYLINDRIQUES SÉRIE LONGUE ET EXTRA-COURTE

Forets pour métaux

Rose



		BC4	BC47	BC40	BC44	BC48	BC78										
		BC3	BC31	BC37	BC33	BC35	BC77	BC43	BC17	BC38							
MATÉRIEL		HSS	HSSCo 5%	HSS	HSSCo 5%	HSSCo 5%	POINTE CARBURE		HSS	HSSCo 5%	HSS	HSSCo 5%	HSSCo 5%	POINTE CARBURE	CARBURE	HSS	HSSCo 5%
AFFÛTAGE																	
ANGLE AFFÛTAGE		118°	135°	118°	135°	135°	118°		135°	135°	135°	135°	118°	118°	135°	135°	135°
HÉLICE																	
FINITION		OX	DORÉ	TiN	BRILLANT	TiAlN	BRILLANT		OX	DORÉ	TiN	BRILLANT	TiAlN	BRILLANT	BRILLANT	OX	DORÉ
APPLICATION				PRODUCTION	INOX	INOX	FORTE				PRODUCTION	INOX	INOX Plus	FORTE	HAUTE PERFORMANCE		
Ø mm	L1 x L2	€	€	€	€	€	€	L1 x L2	€	€	€	€	€	€	€	€	€
0,50	32x13	7,15						23x5									
0,60	37x17	5,81						23x5									14,86
0,70	42x21	5,35						23x5									14,86
0,80	47x23	5,34						23x5									14,86
0,90	51x25	5,34						23x5									
1,00	56x33	5,38						26x6	1,44	2,32	3,67	3,83				8,84	
1,10	56x33	5,22						26x6	1,69								
1,20	60x37	5,22						26x6	1,69								
1,25	65x41	5,41						30x8	1,25	2,77	3,90						
1,30	65x41	5,22						30x8	1,69								
1,40	70x45	5,22						30x9	1,69								
1,50	70x45	3,84		5,05				30x9	1,25	2,19	3,67	4,69				10,11	
1,60	76x50	5,22			8,21			34x10	1,44	2,87	3,90						
1,70	76x50	5,21			8,24			36x11	1,67								
1,75	80x53	4,32						36x11	1,44	2,79	3,90						
1,80	80x53	4,18			7,81			36x11	1,44	2,87	3,90						
1,90	80x53	4,18			8,24			38x12	1,50								
2,00	85x56	2,77	5,53	4,12	8,46	11,13	34,63	38x12	1,24	2,22	3,32	3,40	5,38	21,09	8,64	2,20	
2,10	85x56	3,29			8,15			38x12	1,35	2,72	3,90						9,88
2,20	90x59	3,29			8,21			40x13	1,35	2,72	3,90						9,88
2,25	90x59	3,12						40x13	1,16	2,69	3,90						
2,30	90x59	3,16			7,41			40x13	1,35	2,72	3,90						9,88
2,40	95x62	3,16			9,23			43x14	1,35	2,72	3,90						9,88
2,50	95x62	2,84	5,17	4,07	7,18	10,33	34,29	43x14	1,05	1,85	3,18	3,77	5,04	21,09	9,59	2,17	
2,60	95x62	3,36			8,46			43x14	1,28	2,19	3,47			21,09	9,88		
2,70	100x66	3,36			8,21			46x16	1,28	2,20	3,47						12,97

DIN 340		DIN 1897															
		BC4	BC47	BC40	BC44	BC48	BC78										
MATÉRIEL		HSS	HSSCo 5%	HSS	HSSCo 5%	HSSCo 5%	POINTE CARBURE										
AFFÛTAGE																	
ANGLE AFFÛTAGE		118°	135°	118°	135°	135°	118°										
HÉLICE																	
FINITION		OX	DORÉ	TiN	BRILLANT	TiAlN	BRILLANT										
APPLICATION																	
Ø mm	L1 x L2	€	€	€	€	€	€	L1 x L2	€	€	€	€	€	€	€	€	€
2,75	100x66	3,89						46x16	1,09	2,27	3,47						
2,80	100x66	3,51			8,46			46x16	1,29	2,20	3,47				12,97		
2,90	100x66	3,77			8,45			46x16	1,29	2,20	3,47				12,97		
3,00	100x66	2,64	5,17	3,90	7,28	10,42	30,81	46x16	1,09	1,85	3,18	3,11	4,89	19,15	12,13	1,94	
3,10	106x69	2,93	5,86	4,56	7,64	12,24		49x18	1,19	1,98	3,88	3,47			13,18	1,95	
3,20	106x69	2,93	5,86		7,41	12,16		49x18	1,19	1,98	3,88	3,47			13,18	1,95	
3,25	106x69	2,93	5,86	4,56				49x18	1,19	1,98	3,87			22,35		1,95	3,02
3,30	106x69	2,93			7,21	12,13		49x18	1,21	1,98	3,88	3,47	6,06		13,18	1,94	
3,40	112x73	3,78			9,67			52x20	1,35	2,43	4,21	3,36		22,35	14,17	2,18	
3,50	112x73	2,78	6,09	4,36	8,83	12,50	29,50	52x20	1,19	1,98	3,87	3,65	6,02	19,15	13,21	2,17	3,66
3,60	112x73	3,78			10,56			52x20	1,50	2,43	4,21	4,22			15,59		
3,70	112x73	3,78			10,27			52x20	1,50	2,43	4,21	4,22	6,73		15,59		
3,75	112x73	3,92	6,97	5,52				52x20	1,32	2,51	4,21						2,47
3,80	119x78	4,27			11,43			55x22	1,50	2,43	4,21	4,23			16,79	2,34	
3,90	119x78	4,27	6,97		11,13			55x22	1,50	2,43	4,21	4,23			16,79		
4,00	119x78	3,01	6,31	4,60	8,72	12,82	30,56	55x22	1,32	2,22	3,99	4,05	6,27	17,70	15,68	2,21	3,74
4,10	119x78	3,93	6,96		9,24	13,82		55x22	1,58	2,66	4,31	4,40			17,62	2,34	
4,20	119x78	3,93	6,96		8,97	13,89		55x22	1,58	2,66	4,31	4,46	6,86	19,15	17,62	2,34	
4,25	119x78	3,93	6,96	5,52				55x22	1,58	2,66	4,27					2,39	
4,30	126x82	5,09		5,52	9,99	15,06		58x24	1,79	3,03	4,61	4,74			18,68		
4,40	126x82	5,09			13,01			58x24	1,79	3,03	4,61	4,88			18,68		
4,50	126x82	3,58	7,73	5,22	10,23	15,16	31,23	58x24	1,58	2,66	4,27	4,53	6,97	18,70	18,14	2,47	
4,60	126x82	4,75			13,39			58x24	2,03	3,17	4,73	5,45			18,68		
4,70	126x82	4,75			12,64			58x24	2,03	3,17	4,73	5,24			20,01		
4,75	126x82	5,30	7,76	6,90				58x24	1,74	2,96	4,48					3,98	
4,80	132x87	5,31	7,76		14,00			62x26	2,03	3,17	4,73	5,34			20,01		
4,90	132x87	5,31			14,44			62x26	2,03	3,17	4,73	5,16			20,01		
5,00	132x87	3,84	7,73	5,46	11,06	15,16	31,53	62x26	1,74	2,95	4,48	4,97	7,34	18,70	19,19	2,51	4,77
5,10	132x87	5,88	9,18		11,65	17,21		62x26	2,24	3,63	5,03	5,64		20,02	20,01	3,58	
5,20	132x87	5,88			11,69		34,21	62x26	2,21	3,58	5,03	5,88			25,93	3,58	
5,25	132x87	6,15	9,18	7,70				62x26	1,93	3,28	4,73					3,23	
5,30	132x87	5,99			15,15	17,82		62x26	2,24	3,58	5,03	5,69			25,93		
5,40	139x91	6,40			17,03			66x28	2,24	3,58	5,03	6,19			25,93		
5,50	139x91	5,08	10,60	6,66	12,85	19,58	34,21	66x28	1,93	3,28	4,73	5,89	8,56	20,02	25,17	3,09	
5,60	139x91	6,41			15,69			66x28	2,55	3,82	5,20	6,16			27,54		
5,70	139x91	6,41		8,22	11,13			66x28	2,58	3,82	5,20	6,34		20,02	27,54		
5,75	139x91	6,65	10,72	8,22				66x28	2,22	3,97	5,20					4,76	
5,80	139x91	6,67	10,67		12,09			66x28	2,55	3,82	5,20	6,54			27,54		
5,90	139x91	6,67			16,85			66x28	2,58	3,82	5,20	6,51			27,54		
6,00	139x91	4,70	10,67	6,25	13,34	19,73	34,18	66x28	2,21	3,73	5,03	6,29	8,96	20,87	28,05	3,15	
6,10	148x97	7,02			19,18			70x31	3,02	4,82	9,41	6,82		21,79	34,30		
6,20	148x97	7,02			19,25			70x31	3,02	4,82	9,41	6,72			34,30		
6,25	148x97	7,30		8,93				70x31	2,62	4,97	9,41						
6,30	148x97	7,11						70x31	3,02	4,82	9,41	6,54			34,30		
6,40	148x97	7,11						70x31	3,02	4,83	9,41	6,55			34,30		
6,50	148x97	6,04	12,18	10,24	16,53	26,74	36,79	70x31	2,59	4,44	7,46	6,74	13,68	21,79	32,99		
6,60	148x97	7,11						74x34	3,50	6,00	8,44	7,36			40,35		
6,70	148x97	7,11			14,85			74x34	3,50	6,00	8,44	7,27			40,35		
6,75	156x102	7,40	14,04	11,55				74x34	3,06	6,20	8,44						
6,80	156x102	7,39			15,57	30,18		74x34	3,03	6,18	8,44	7,61	16,87	27,51	40,35		
6,90	156x102	7,55						74x34	3,33					27,51	40,35		

FORETS CYLINDRIQUES SÉRIE LONGUE ET EXTRA-COURTE
**DIN
340**

**DIN
1897**

		BC4	BC47	BC40	BC44	BC48	BC78			BC3	BC31	BC37	BC33	BC35	BC77	BC43	BC17	BC38
MATÉRIEL		HSS	HSSCo 5%	HSS	HSSCo 5%	HSSCo 5%	POINTE CARBURE			HSS	HSSCo 5%	HSS	HSSCo 5%	HSSCo 5%	POINTE CARBURE	CARBURE	HSS	HSSCo 5%
AFFÛTAGE																		
ANGLE AFFÛTAGE		118°	135°	118°	135°	135°	118°			135°	135°	135°	135°	118°	118°	135°	135°	135°
HÉLICE																		
FINITION		OX	DORÉ	TiN	BRILLANT	TiAlN	BRILLANT			OX	DORÉ	TiN	BRILLANT	TiAlN	BRILLANT	BRILLANT	OX	DORÉ
APPLICATION																		
Ø mm	L1 x L2	€	€	€	€	€	€	L1 x L2	€	€	€	€	€	€	€	€	€	€
14,00	214x140	27,19					101,01	107x54	15,23	25,77	31,19	36,75		67,51	165,50			
14,25	220x144	49,00																
14,50	220x144	31,81						111x56	17,53	35,75	39,39	42,41			270,93			
14,75	220x144	49,00																
15,00	220x144	30,80					104,57	111x56	20,05	36,31	39,71	46,77		83,42	177,80			
15,25	227x149	55,29																
15,50	227x149	45,69						115x58	24,15	41,98	43,10	50,86			326,12			
15,75	227x149	55,30																
16,00	227x149	35,84					135,86	115x58	24,15	43,55	44,03	55,00		96,76	221,01			
16,25	235x154	61,02																
16,50	235x154	42,41						119x60	28,41	49,79	50,55							
16,75	235x154	61,02																
17,00	235x154	42,60					173,13	119x60	28,41	49,79	50,55							
17,25	241x158	70,16																
17,50	241x158	62,94						123x62	31,65	55,15	53,72							
17,75	241x158	81,97																
18,00	241x158	44,40					181,13	123x62	31,65	60,09	56,69							
18,25	247x162	85,71																
18,50	247x162	68,75						127x64	35,26	66,34	63,81							
18,75	247x162	119,34																
19,00	247x162	55,68						127x64	35,26	66,34	63,81							
19,25	254x166	123,55																
19,50	254x166	107,07						131x66	42,26	73,58	68,12							
19,75	254x166	120,91																
20,00	254x166	62,47					251,29	131x66	42,26	78,85	72,15				555,45			

FORETS CYLINDRIQUES DIN 1869 SÉRIE EXTRA-LONGUE I/ II/ III

DIN 1869 I/II/III



		BC8	BC88
MATÉRIEL		HSS	HSSCo 5%
AFFÛTAGE			
ANGLE AFFÛTAGE		118°	135°
HÉLICE		30° "N"	38° "S"
FINITION		OX	BRILLANT
APPLICATION		70 Kg/mm²	INOX
Ø mm	L1 x L2	€	€
0,50	50x25	13,35	
0,60	60x30	13,35	
0,70	60x30	13,49	
0,70	80x50	15,30	
0,80	60x30	13,76	
0,80	80x50	15,56	
0,80	120x60	17,88	
1,00	80x50	12,93	
1,00	100x70	14,16	
1,00	150x75	18,91	
1,50	100x70	13,26	
1,50	140x100	15,82	
2,00	100x70	10,63	
2,00	125x85	11,62	16,01
2,00	150x100	14,68	
2,00	160x125		24,65
2,00	200x135		31,26
2,25	135x90		20,58
2,50	140x95	11,23	16,31
2,50	180x130		33,32
2,50	225x150		39,35
2,75	150x100		22,56
3,00	150x100	12,43	18,01
3,00	190x130	14,69	22,19
3,00	240x160		38,98
3,25	155x105		22,56
3,25	200x135		27,84
3,50	165x115	12,76	18,26
3,50	210x145	16,53	23,46
3,50	265x180	23,66	31,83
3,75	165x115		26,11
3,75	210x145		27,84
3,75	265x180		36,78
4,00	175x120	13,59	18,26
4,00	220x150	16,91	23,46
4,00	280x190	24,11	31,83
4,25	175x120		27,69
4,25	220x150	26,82	35,78
4,25	280x190		44,75
4,50	185x125	15,20	21,37
4,50	235x160	20,03	27,87
4,50	295x220	28,43	39,60

		BC8	BC88
Ø mm	L1 x L2	€	€
4,75	185x125		28,49
4,75	235x160		35,78
4,75	295x200		44,75
5,00	195x135	15,52	28,71
5,00	245x170	21,58	32,46
5,00	315x210	26,47	37,43
5,25	195x135		28,91
5,25	245x170		39,94
5,25	315x210		47,86
5,50	205x140	18,13	22,89
5,50	260x180	24,76	34,63
5,50	330x225	32,53	42,57
5,75	205x140	21,68	28,91
5,75	260x180	29,96	39,94
5,75	330x225	36,38	48,48
6,00	205x140	18,76	22,88
6,00	260x180	27,93	34,63
6,00	330x225	33,02	42,69
6,25	215x150		33,87
6,25	275x190		41,79
6,25	350x235		53,96
6,50	215x150	21,27	28,36
6,50	275x190	30,40	38,21
6,50	350x235	37,44	48,78
6,75	225x155		36,78
6,75	290x200		48,28
6,75	370x250		68,43
7,00	225x155	23,66	35,17
7,00	290x200	33,23	42,69
7,00	370x250	47,43	62,88
7,25	225x155		46,85
7,25	290x200		57,75
7,25	370x250		77,16
7,50	225x155	28,37	38,82
7,50	290x200	37,81	50,86
7,50	370x250	55,87	71,43
7,75	240x165		48,28
7,75	305x210		57,75
7,75	390x265		85,35
8,00	240x165	30,40	39,60
8,00	305x210	39,57	49,55
8,00	390x265	56,24	73,36
8,25	240x165		63,30
8,25	305x210		84,04
8,25	390x265		102,07
8,50	240x165	38,88	53,74
8,50	305x210	53,71	74,94
8,50	390x265	72,81	91,78
8,75	240x165		67,65
8,75	320x220		84,04
8,75	410x280		107,47

		BC8	BC88
Ø mm	L1 x L2	€	€
9,00	250x175	40,45	57,34
9,00	320x220	53,13	72,06
9,00	410x280	77,68	97,43
9,25	250x175		79,10
9,25	320x220		100,87
9,25	410x280		126,13
9,50	250x175	47,43	66,38
9,50	320x220	65,71	86,16
9,50	410x280	87,94	114,52
9,75	265x185		80,71
9,75	340x235		105,10
9,75	430x295		135,46
10,00	265x185	48,08	60,16
10,00	340x235	61,96	79,21
10,00	430x295	85,51	111,66
10,25	265x185		114,00
10,25	340x235		123,59
10,25	430x295		131,43
10,50	265x185	82,94	101,71
10,50	340x235	89,89	110,24
10,50	430x295	95,58	117,24
10,75	280x195		114,00
10,75	365x250		123,59
10,75	455x310		131,43
11,00	280x195	59,53	76,26
11,00	365x250	80,70	98,99
11,00	455x310	94,48	115,86
11,25	280x195		106,17
11,25	365x250		142,55
11,25	455x310		147,25
11,50	280x195	77,22	94,73
11,50	365x250	103,67	127,18
11,50	455x310	107,12	131,36
11,75	280x195		106,17
11,75	365x250		142,55
11,75	455x310		147,25
12,00	295x205	79,83	86,16
12,00	375x260	91,04	111,66
12,00	480x330	110,80	135,89
12,25	295x205		123,59
12,25	375x260		138,40
12,25	480x330		167,98
12,50	295x205	89,89	110,24
12,50	375x260	100,64	123,47
12,50	480x330	122,17	149,84
12,75	295x205		123,59
12,75	375x260		138,40
12,75	480x330		167,98
13,00	295x205	89,89	110,24
13,00	375x260	103,71	127,18
13,00	480x330	123,33	151,27

*Consulter les autres longueurs spéciales disponibles

FORETS À QUEUE CYLINDRIQUE POUR L'AVIATION

Réf. BC08

HSS



AIRCRAFT

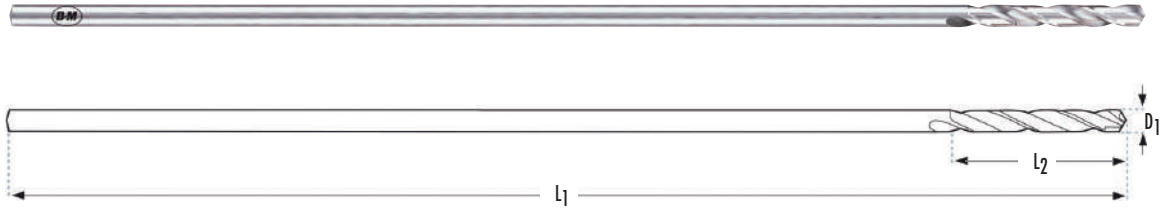

150 mm

				BC08
	D ₁ mm	L ₁ mm	L ₂ mm	€
BC080225150	2,25	150	25	14,38
BC080250150	2,50	150	25	13,87
BC080320150	3,20	150	26	13,85
BC080325150	3,25	150	36	13,67
BC080400150	4,00	150	43	14,14

300 mm

				BC08
	D ₁ mm	L ₁ mm	L ₂ mm	€
BC080225300	2,25	300	25	15,29
BC080250300	2,50	300	25	14,45
BC080320300	3,20	300	26	14,48
BC080325300	3,25	300	36	14,44
BC080400300	4,00	300	43	16,15

* Autres diamètres disponibles sur demande

FORET EXTRA-LONG POINTE CARBURE POUR L'AVIATION

Réf. BC08PMD

POINTE
CARBUREAIRCRAFT
MD

85°

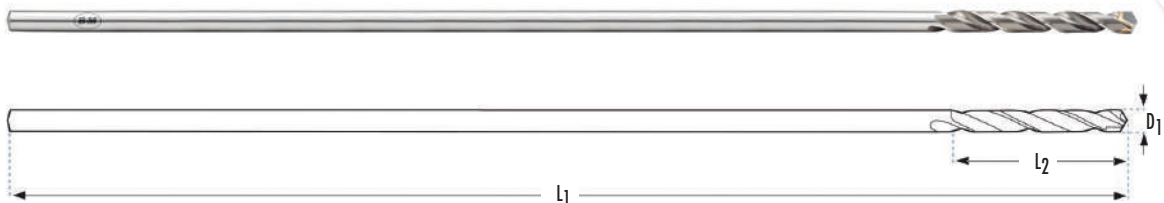

* Série Aircraft MD: Fabrication de mesures spéciales sur demande.

FORETS À CENTRER

Réf. BC10
Réf. BC10Co
Réf. BC65

Réf. BC10I
Réf. BC10MD
Réf. BC10W

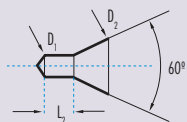

DIN
333A



DIN
333W

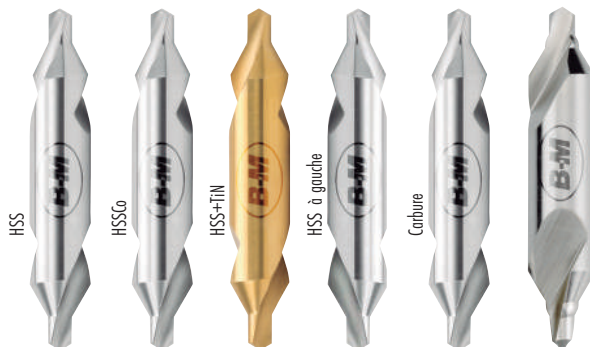
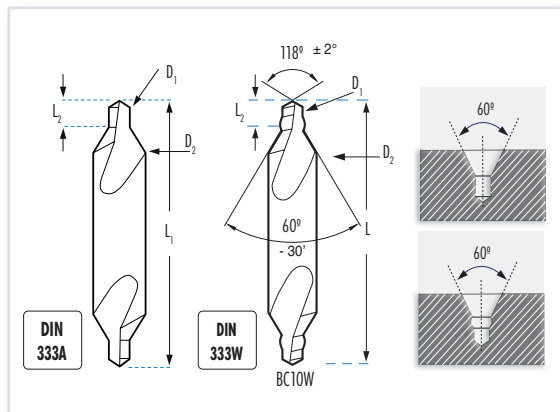

D1 x D2 mm	L1 x L2 mm	BC10	BC10Co	BC65	BC10I	BC10MD	BCW10
		HSS	HSSCo 5%	TiN	HSS	CARBURE	HSS
		€	€	€	€	€	€
0,50 x 3,00	31 x 1	14,42		19,88			17,30
0,50 x 3,15*	25 x 1	8,47	9,21	14,10			10,16
0,63 x 3,15*	25 x 1	8,47		14,10		62,11	
0,80 x 3,15*	25 x 1	8,32	9,21	13,97			9,99
1,00 x 3,15	31 x 1	6,16	9,21	11,88		62,11	7,39
1,25 x 3,15	33 x 1	5,71	9,21	11,88		62,11	6,85
0,75 x 3,50	35 x 1	8,99	9,21	15,09			
1,00 x 4,00	35 x 1	7,74	9,21	13,86		64,79	9,28
1,25 x 4,00	35 x 1	6,54		12,69			7,85
1,50 x 5,00	40 x 2	7,45	9,91	13,79		71,71	8,94
1,60 x 4,00	37 x 2	5,98	9,21	12,34	10,45	66,32	7,18
1,60 x 5,00	40 x 2	6,51		12,88			7,81
2,00 x 5,00	42 x 2	6,62	9,91	13,00	11,58	75,57	7,95
2,00 x 6,00	45 x 2	7,45	10,44	15,02		82,54	8,94
2,00 x 6,30	45 x 2	6,70		14,55	12,41		8,84
2,50 x 6,30	47 x 3	7,35	11,01	14,72	12,88	86,12	8,83
2,50 x 8,00	50 x 3	8,13	11,01	15,43	14,20	96,63	9,75
3,00 x 8,00	50 x 3	8,13	11,61	15,69		96,63	9,75
3,15 x 8,00	52 x 4	8,10	12,10	15,51	14,15	96,63	9,71
3,00 x 10,00	55 x 4	10,57	16,05	20,18		118,03	12,68
3,15 x 10,00	56 x 4	9,57		20,55	16,72		11,48
4,00 x 10,00	59 x 5	11,24	16,05	20,82	19,63	118,03	13,48
4,00 x 12,00	63 x 5	18,16	25,30	26,87			21,79
4,00 x 12,50	63 x 5	13,08		26,87	22,86		21,79
5,00 x 12,00	63 x 5	18,16	25,30	26,87		186,58	21,79
5,00 x 12,50	66 x 6	18,79	26,44	27,59	32,82	197,13	22,54
5,00 x 14,00	69 x 6	31,21	34,94	40,82			37,45
5,00 x 16,00	71 x 6	27,09		37,15	47,35		32,51
6,30 x 16,00	74 x 8	26,96	37,84	37,15		305,91	32,35
6,30 x 18,00	77 x 8	47,51		60,50			57,02
6,30 x 20,00	80 x 8	47,51		55,86			61,77
8,00 x 20,00	81 x 27	50,03	103,55	73,22			60,03
8,00 x 25,00	100 x 10	113,49		144,34			
10,00 x 25,00	100 x 31	80,74	113,97	112,54			96,89
10,00 x 31,50	125 x 12	239,51		288,78			
12,50 x 31,50	125 x 33	192,06	249,62	243,73			



FORETS À CENTRER

 Réf. BC64
 Réf. BC68

**DIN
333A**
SÉRIE LONGUE

Réf. BC62

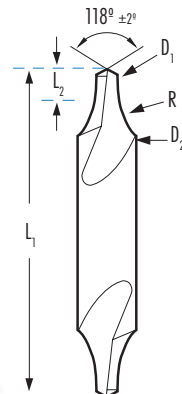
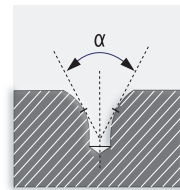
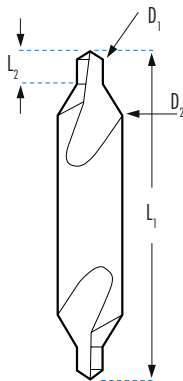
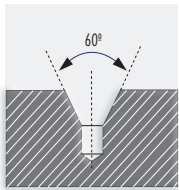
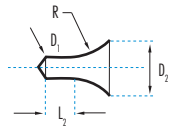
**DIN
333R**

D1 x D2 mm	L1 x L2 mm	BC64		BC68	
		HSS €	TiN €	HSS €	TiN €
1,00 x 4,00	60 x 1	21,09	26,86		
1,00 x 4,00	120 x 1	42,63	68,34		
1,50 x 5,00	60 x 2	21,51	27,21		
1,50 x 5,00	120 x 2	43,45	60,48		
2,00 x 5,00	200 x 2	88,86	150,74		
2,00 x 6,00	80 x 2	22,42	29,55		
2,00 x 6,00	120 x 2	33,96	59,76		
2,50 x 6,30	200 x 2	87,27	149,15		
2,50 x 8,00	80 x 3	27,28	38,44		
2,50 x 8,00	120 x 3	41,30	70,85		
3,00 x 8,00	80 x 4	27,28	38,44		
3,00 x 8,00	120 x 4	41,30	70,85		
3,15 x 8,00	200 x 4	82,50	144,39		
3,00 x 10,00	100 x 4	35,23	48,33		
3,00 x 10,00	120 x 4	42,67	80,19		
4,00 x 10,00	100 x 5	35,27	48,33		
4,00 x 10,00	120 x 5	42,73	80,19		
4,00 x 10,00	200 x 5	90,44	152,33		
4,00 x 12,00	100 x 5	47,49	72,20		
4,00 x 12,00	120 x 5	57,54	102,09		
5,00 x 14,00	120 x 6	80,56	123,03		

D1 x D2 mm	L1 x L2 mm	BC62		BC62MDI	
		HSS €	Carbure €	HSS €	Carbure €
0,50 x 3,00	31 x 2,3	10,12			
0,50 x 3,15	25 x 2,3	6,73	46,26		
0,80 x 3,15	25 x 2,6	6,73			
1,00 x 3,15	31 x 3,0	6,38	48,27		
1,25 x 3,15	31 x 3,3	6,38	48,27		
0,50 x 3,50	35 x 2,7	10,12			
0,75 x 3,50	35 x 2,8	6,73			
1,00 x 4,00	35 x 3,3	6,73			
1,25 x 4,00	35 x 3,7	6,40			
1,60 x 4,00	37 x 4,0	6,38	52,29		
1,50 x 5,00	40 x 4,5	7,36			
1,60 x 5,00	40 x 4,5	7,16			
2,00 x 5,00	42 x 5,0	6,91	62,34		
2,00 x 6,00	45 x 5,4	8,20			
2,00 x 6,30	45 x 6,0	8,00			
2,50 x 6,30	47 x 6,0	8,06	74,41		
2,50 x 8,00	50 x 7,0	8,51			
3,00 x 8,00	50 x 8,0	8,94			
3,15 x 8,00	52 x 8,0	8,96	90,50		
3,00 x 10,00	55 x 8,9	11,64			
3,15 x 10,00	56 x 9,0	10,98			
4,00 x 10,00	56 x 10,0	10,98	123,88		
4,00 x 12,00	63 x 10,7	18,39			
5,00 x 12,00	63 x 11,4	18,39			
4,00 x 12,50	63 x 11,0	18,48			
5,00 x 12,50	66 x 13,0	18,53	197,09		
5,00 x 14,00	69 x 12,8	25,09			
5,00 x 16,00	71 x 15,0	26,31			
6,30 x 16,00	74 x 17,0	26,37			
6,00 x 18,00	77 x 16,6	41,57			
6,30 x 20,00	80 x 19,0	47,19			
8,00 x 20,00	80 x 21,0	49,64			
10,00 x 25,00	100 x 26,0	82,99			
12,50 x 31,50	125 x 33,0	192,08			

FORETS À CENTRER

FORETS À POINTER

Ref. BC63

DIN 333B

HSS

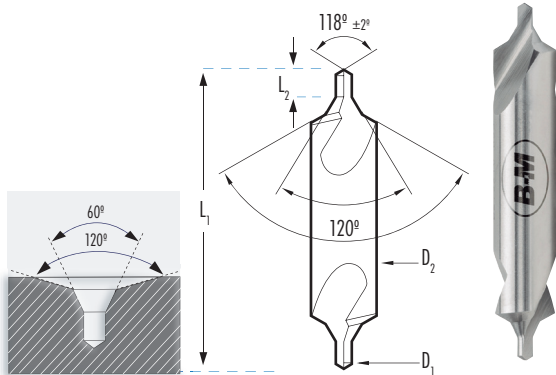
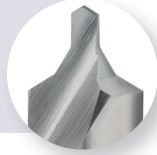

BC63

D1 x D2 mm	L1 x L2 mm	€
0,50 x 3,00	31,00 x 0,6	12,59
0,75 x 4,00	35,00 x 1,0	11,28
1,00 x 4,00	37,50 x 1,60	11,28
1,25 x 5,00	42,00 x 1,90	11,28
1,50 x 5,00	40,00 x 2,00	12,05
1,00 x 6,00	45,00 x 1,30	12,05
2,00 x 6,00	45,00 x 2,50	12,05
1,60 x 6,30	47,00 x 2,40	11,28
1,50 x 8,00	50,00 x 2,00	12,64
2,00 x 8,00	52,00 x 2,90	11,83
2,50 x 8,00	50,00 x 3,10	13,75
3,00 x 8,00	50,00 x 3,90	14,14
2,00 x 10,00	55,00 x 2,50	14,42
2,50 x 10,00	59,00 x 3,60	13,69
3,00 x 10,00	55,00 x 3,90	16,35
4,00 x 10,00	55,00 x 5,00	16,46
3,15 x 11,20	63,00 x 4,40	15,82
2,50 x 12,00	63,00 x 3,10	21,27
4,00 x 12,00	63,00 x 5,00	21,85
5,00 x 12,00	63,00 x 6,30	23,23
3,00 x 14,00	69,00 x 3,90	26,70
4,00 x 14,00	70,00 x 5,60	24,33
5,00 x 14,00	69,00 x 6,30	31,63
4,00 x 16,00	71,00 x 5,00	34,03
4,00 x 18,00	77,00 x 5,00	37,50
5,00 x 18,00	78,00 x 6,90	33,64
6,00 x 18,00	77,00 x 8,00	44,74
5,00 x 20,00	80,00 x 6,30	63,54
6,30 x 20,00	83,00 x 8,60	49,05
6,00 x 25,00	100,00 x 8,00	113,06
6,30 x 25,00	100,00 x 8,00	113,06
8,00 x 25,00	100,00 x 26,00	108,36
10,00 x 31,50	125,00 x 30,00	214,71

Ref. BC75
Ref. BI75
Ref. BC76

HSSCo 5%

TiAIN

DIN 1412A

D₂

TOL h6

Utilisés pour le centrage préliminaire pour des perçages réalisés avec des forets. Prépare le perçage du foret. Augmente la vitesse d'attaque lors du perçage.

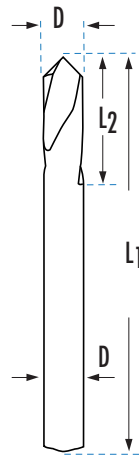

BC75 BI75 BC76 BH75

D mm	L1 x L2 mm	90°	90°	120°	142°
		€	€	€	€
2,0	49 x 8	13,37		13,37	
3,0	50 x 10	13,55	68,14	13,55	27,90
4,0	52 x 12	15,01	72,70	15,01	27,90
5,0	60 x 15	16,22	77,24	16,22	31,46
6,0	66 x 20	18,51	81,77	18,51	31,46
8,0	79 x 25	22,57	90,86	22,57	35,53
10,0	89 x 25	22,67	102,22	22,67	35,53
12,0	102 x 30	31,43	113,58	31,43	49,01
16,0	115 x 35	65,10		65,10	67,41
20,0	131 x 40	85,08		85,08	132,65

FORET À POINTER DOUBLE POINTE

Ref. DP75

HSSCo 5%

TiAIN

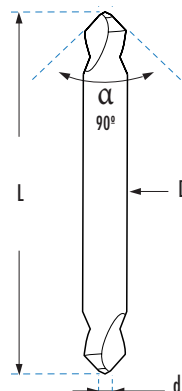
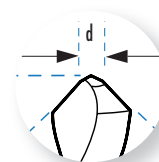

D x d mm	L mm	DP75
		90° €
3,0 x 0,5	40	27,58
4,0 x 1,0	45	27,70
6,0 x 2,0	55	31,42
8,0 x 2,5	65	36,28
10,0 x 3,0	75	38,93
12,0 x 3,5	85	48,03
16,0 x 4,0	90	73,98
20,0 x 5,0	100	121,36



FORETS À POINTER

Utilisés pour le centrage préliminaire pour des perçages réalisés avec des forets. Prépare le perçage du foret. Augmente la vitesse d'attaque lors du perçage.

DIN
1412A
D₂
TOL
h6

FORET À POINTER CARBURE

 Réf. BC92
 Réf. BC93

CARBURE
DIN
1412A
TOL
h6
DIN
6535HB

D mm	L1 x L2 mm	BC92		BC93	
		90° €	120° €	90° €	120° €
1,0	26 x 6	25,10			
1,5	32 x 9	25,48			
2,0	38 x 12	25,75			
3,0	45 x 12	26,10	26,85		
4,0	50 x 15	26,39	30,16		
5,0	50 x 18	31,43	32,31		
6,0	50 x 13	41,21	42,38		
8,0	60 x 23	58,00	59,66		
10,0	70 x 24	82,22	84,56		
12,0	70 x 24	106,17	109,21		
14,0	70 x 27	158,13	162,64		
16,0	75 x 29	195,38	200,96		
18,0	100 x 33	287,96	296,19		
20,0	100 x 35	346,43	356,34		

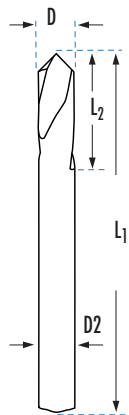

FORET À POINTER MULTI-FONCTIONS

Réf. BN75

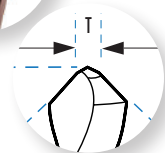
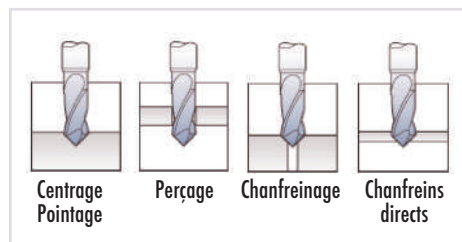
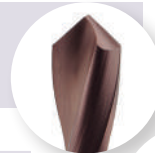
HSSCo
5%
120
Kg/mm²

	D mm	L1 x L2 mm	T* mm	BN75	
				90° €	
BN750300	3,0	50 x 6	0,3	32,64	
BN750400	4,0	52 x 8	0,4	35,39	
BN750500	5,0	60 x 10	0,5	38,43	
BN750600	6,0	66 x 12	0,6	41,19	
BN750800	8,0	79 x 14	0,8	49,72	
BN751000	10,0	89 x 16	1,0	59,49	
BN751200	12,0	102 x 18	1,2	77,78	
BN751400	14,0	115 x 21	1,4	109,81	
BN751600	16,0	115 x 24	1,6	122,01	



T*: Épaisseur d'âme

FORETS À POINTER SÉRIE LONGUE

Réf. BL75

HSSCo
5%
TiAIN
90°

D1 mm	L1 x L2 mm	BL75	
		€	
3,0	80 x 10	45,43	
4,0	100 x 12	49,98	
5,0	120 x 15	54,52	
6,0	140 x 20	59,06	
8,0	140 x 25	65,87	
10,0	170 x 25	81,77	
12,0	170 x 30	99,95	
16,0	200 x 35	134,01	
20,0	200 x 40	170,36	

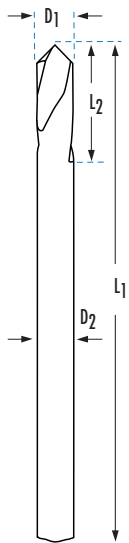

FORETS À POINTER À QUEUE CONIQUE

Réf. BP11

HSSCo
5%
120
Kg/mm²
90°

D1 mm	L1 mm	L2 mm	L3 mm	CM	BP11	
					€	
10,0	130	25	64	1	136,30	
12,0	130	30	64	1	147,65	
16,0	148	35	68	2	181,72	
20,0	148	40	68	2	227,16	
25,0	171	45	72	3	306,66	

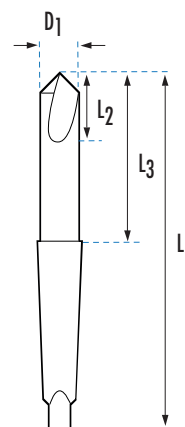

FORET À DÉPOINTER LES POINTS DE SOUDURE

FORETS COURTS POUR MACHINES PNEUMATIQUES

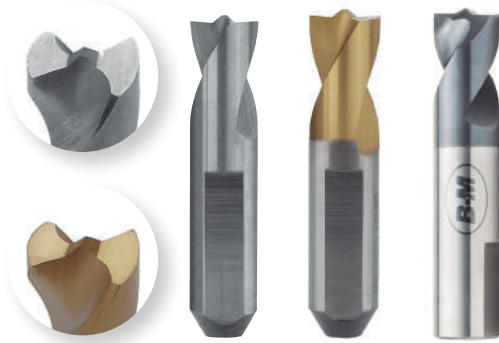

D1 mm	D2 mm	L1 x L2 mm	BC70	BC71	BC70MD*
			HSSCo 8%	HSSCo 8%	CARBURE
			TiN	TiAIN	
			€	€	€
6,0	8,0	45 x 18	25,90	33,67	
6,5	6,5	40 x 18	24,84	38,55	66,91
8,0	8,0	38 x 18	21,37	33,67	
8,0	8,0	45 x 18	23,82	38,55	73,03
9,0	8,0	45 x 18	26,00	41,88	
10,0	8,0	45 x 18	28,49	45,98	

*** FORET SPÉCIAL BC70MD CARBURE MONOBLOC +TiAIN**

- Foret spécial pour soudures au Bore.
- Utiliser des perceuses électriques, non pneumatiques.
- Efforts de poussée élevés.
- Toujours avec Cut - Magic.
- 1200 RPM.

FORETS LONGS POUR PERCEUSES ELECTROPORTATIVES

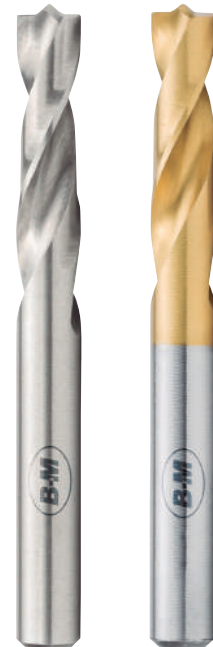

Ø mm	L1 x L2 mm	BC60	BC69
		HSSCo 5%	HSSCo 5%
		TiN	
		€	€
6,0	66 x 26	12,05	21,56
7,0	74 x 34	17,61	28,04
8,0	79 x 36	16,43	30,37
10,0	89 x 44	20,69	32,11

ENSEMBLE COUPANT: ARBRE, SCIE-CLOCHE ET GUIDE



EBC70-1
23,62 €

SCIE-CLOCHE: DE 9,5 MM



EBC70-2
17,09 €

GUIDE



EBC70-3
1,04 €



EBC70

Composition:

- 1 Ensemble coupant Ref. EBC70-1
- 5 Scie Cloches de 9,5 mm Ref. EBC70-2
- 2 Guides Ref. EBC70-3
- 1 Foret Ref. BC60 Ø 8 mm

107,10 €

FORETS FRAISEURS

POUR PERÇAGE ET CONTOURNAGE DANS LE BOIS, LES TÔLES MÉTALLIQUES ET LE PLASTIQUE



* Foret spécial pour carrossiers

Ø mm	L1 x L2 mm	BC80	BC81
		HSS	TiN
		€	€
6,0	90 x 60	18,16	28,50
8,0	90 x 60	23,36	36,49

FORET FRAISE CARBURE MONOBLOC

Ref. BC91

CARBURE

Pour percer, pointer, fraiser et chanfreiner



Ti

INC

Ni

INOX

PVC

D2
TOL h6

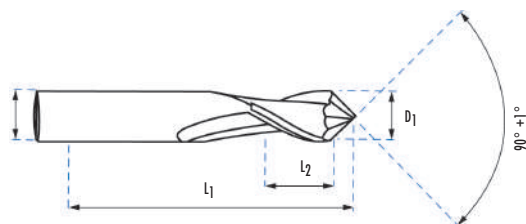

D1
TOL h9



BC91			
D1 mm	D2 mm	L1 x L2 mm	€
3,0	3,0	50 x 6	61,94
4,0	4,0	50 x 8	66,01
5,0	5,0	50 x 10	71,86
6,0	6,0	60 x 12	82,62
8,0	8,0	70 x 16	114,73
10,0	10,0	70 x 18	168,35
12,0	12,0	70 x 20	168,35
14,0	14,0	88 x 30	212,64
16,0	16,0	80 x 26	240,46
20,0	20,0	100 x 32	424,83



Centrage
Pointage

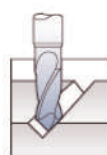

Rainurage
en V



Usinage

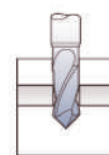

Perçage



Chanfreinage

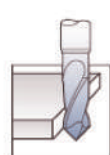

Contournage



Chanfreinage longitudinal

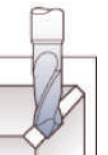

Chanfreins
directs



Gravage

FLUOFORET POUR TARAUDAGE DE TÔLES FINES

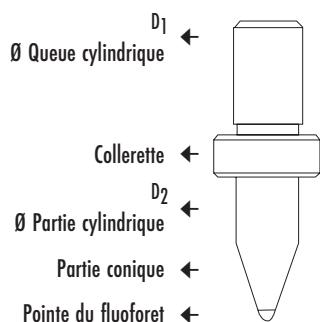
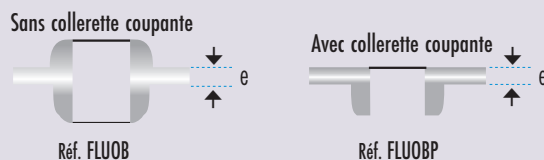

	e max. mm	D1 mm	D2 mm	R.P.M.	FLUOB		FLUOBP	
						€		€
M3x0,50	1,7	6	2,7	3000	FLUOBM03	138,52	FLUOBPM03	193,94
M4x0,70	1,7	6	3,7	2600	FLUOBM04	143,56	FLUOBPM04	200,99
M5x0,80	2,0	8	4,5	2500	FLUOBM05	149,94	FLUOBPM05	217,85
M6x1,00	2,0	8	5,3	2400	FLUOBM06	159,83	FLUOBPM06	232,19
M8x1,25	2,4	8	7,3	2200	FLUOBM08	197,20	FLUOBPM08	286,50
M10x1,50	2,6	10	9,2	2000	FLUOBM10	223,47	FLUOBPM10	324,67
M12x1,75	3,0	12	10,9	1800	FLUOBM12	239,60	FLUOBPM12	329,22
M16x2,00	3,4	16	14,8	1200	FLUOBM16	330,48	FLUOBPM16	422,10
M20x2,50	3,8	18	18,7	800	FLUOBM20	466,49	FLUOBPM20	595,04

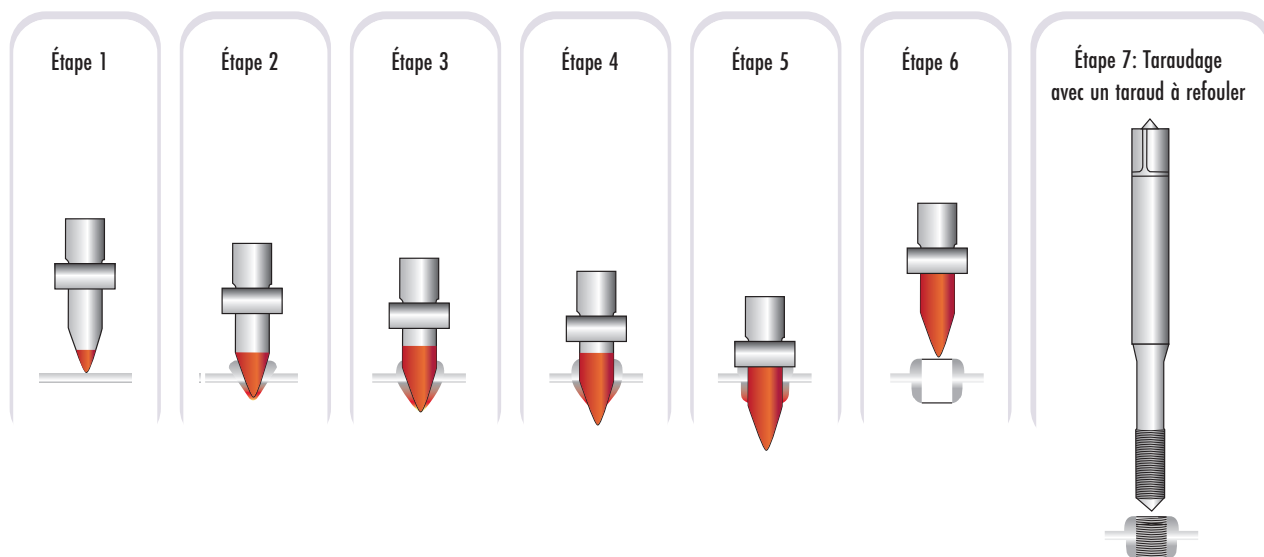

LUBRIFIANT POUR FLUOPERÇAGE (250ml. et 750ml.)

			PASTY
		UNITÉ EMBALLAGE	€
ACPU00250	0,250 l.	1 Boîte	28,92
ACPU00750	0,750 l.	1 Boîte	43,76



Ref. ACPU00250

Ref. ACPU00750

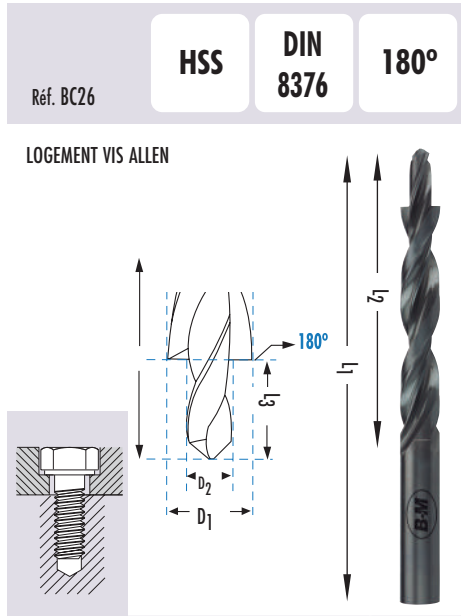
FORETS BI-DIAMÉTRAUX HSS
QUEUE CYLINDRIQUE ET QUEUE CONIQUE

BC26

	D2 mm	D1 mm	L1 x L2 mm	L3 mm	€
M3	3,4	6	93 x 57	9	52,35
M4	4,5	8	117 x 75	11	54,91
M5	5,5	10	133 x 87	13	65,85
M6	6,6	11	142 x 94	15	73,75
M8	9,0	15	169 x 114	19	90,59
M10	11,0	18	191 x 130	23	180,04

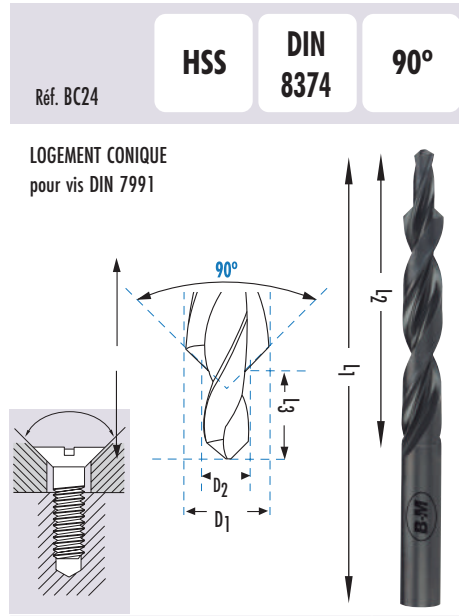

BC24

	D2 mm	D1 mm	L1 x L2 mm	L3 mm	€
M3	3,2	6,0	93 x 57	9	61,09
M4	4,3	8,0	117 x 75	11	64,06
M5	5,3	10,0	133 x 87	13	76,14
M6	6,4	11,5	142 x 94	15	86,97
M8	8,4	15,0	169 x 114	19	118,97
M10	10,5	19,0	198 x 135	23	183,69

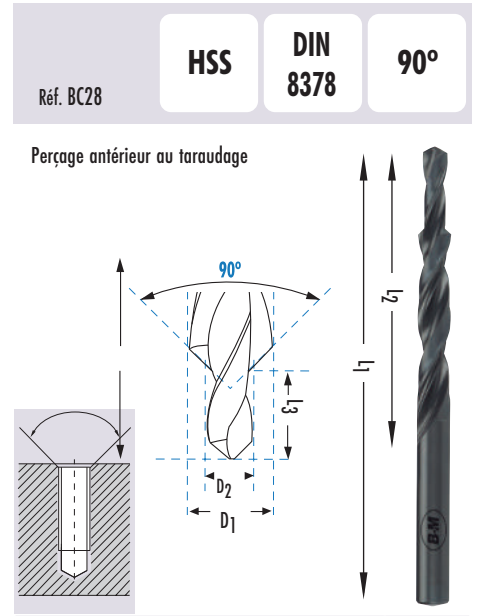

BC28

	D2 mm	D1 mm	L1 x L2 mm	L3 mm	€
M3	2,5	3,4	70 x 39	8,8	47,39
M4	3,3	4,5	80 x 47	11,8	51,00
M5	4,2	5,5	93 x 57	13,6	54,94
M6	5,0	6,6	101 x 63	16,5	62,50
M8	6,8	9,0	125 x 81	21,0	74,48
M10	8,5	11,0	142 x 94	25,5	86,87
M12	10,2	13,5	160 x 108	30,0	108,17

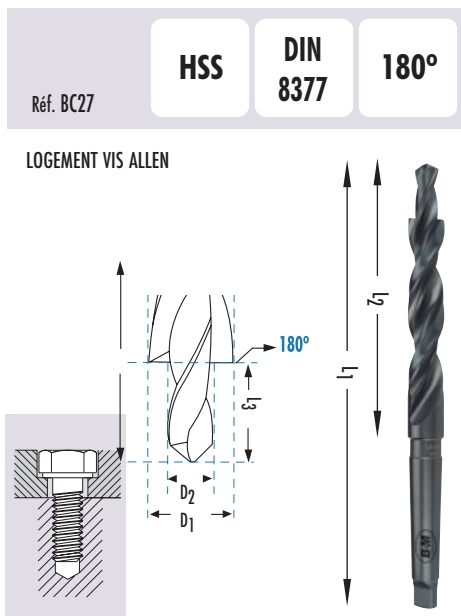

BC27

	D2 mm	D1 mm	L1 x L2 mm	L3 mm	CM	€
M6	6,6	11	175 x 94	15	1	146,93
M8	9,0	15	212 x 114	19	2	151,74
M10	11,0	18	228 x 130	23	2	171,08
M12	13,5	20	238 x 140	27	2	191,36
M14	15,5	24	281 x 160	31	3	271,37
M16	17,5	26	286 x 165	35	3	386,93
M18	20,0	30	296 x 175	39	3	432,68
M20	22,0	33	334 x 185	43	4	489,24

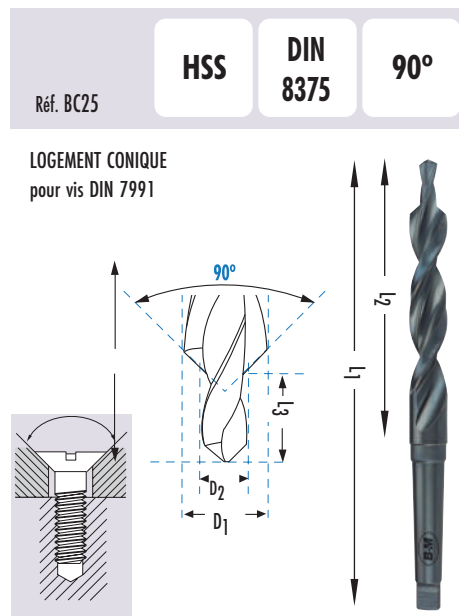

BC25

	D2 mm	D1 mm	L1 x L2 mm	L3 mm	CM	€
M5	5,5	11,0	175 x 94	13	1	146,78
M6	6,6	13,0	182 x 101	15	1	149,74
M8	9,0	17,2	228 x 130	19	2	178,47
M10	11,0	21,5	248 x 150	23	2	211,28

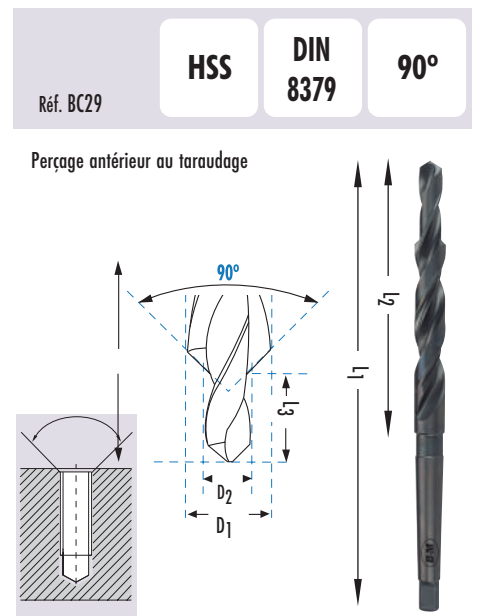

BC29

	D2 mm	D1 mm	L1 x L2 mm	L3 mm	CM	€
M8	6,8	9,0	162 x 81	21,0	1	134,62
M10	8,5	11,0	175 x 94	25,5	1	146,68
M12	10,2	13,5	189 x 108	30,0	1	173,26
M14	12,0	15,5	218 x 120	34,5	2	184,90
M16	14,0	17,5	228 x 130	38,5	2	199,53
M18	15,5	20,0	238 x 140	43,5	2	223,18
M20	17,5	22,0	248 x 150	47,5	2	269,85

FORETS BI-DIAMÉTRAUX EXTRA-COURTS

Réf. BC36

HSSCo 5% **90°**

BC36

	D1 mm	D2 mm	D3 mm	L1 x L2 mm	L3 mm	€
M3	3,4	2,5	3,4	52 x 20	8	27,21
M4	4,5	3,3	4,5	58 x 24	11	27,90
M5	5,5	4,2	5,5	66 x 28	13	31,03
M6	6,6	5,0	6,6	70 x 31	16	33,73
M8	9,0	6,8	9,0	84 x 40	20	40,48
M10	11,0	8,5	11,0	95 x 47	24	53,30
M12	14,0	10,2	14,0	107 x 54	29	71,51
M14	16,0	12,0	16,0	115 x 56	32	182,17
M16	18,0	14,0	18,0	135 x 60	34	229,38

Réf. BCMD36

CARBURE **90°** **TiAlN**

BCMD36

	D1 mm	D2 mm	D3 mm	L1 x L2 mm	L3 mm	€
M3	6,0	2,5	6,0	66 x 20	8,8	53,97
M4	6,0	3,3	6,0	66 x 24	11,4	62,96
M5	6,0	4,2	6,0	66 x 28	13,6	67,48
M6	8,0	5,0	8,0	79 x 31	16,5	78,71
M8	10,0	6,8	10,0	89 x 40	21,0	107,94
M10	12,0	8,5	12,0	102 x 47	25,5	146,18
M12	14,0	10,2	14,0	107 x 54	30,0	202,41

Réf. BC74

HSSCo 5% **180°**

BC74

	D1 mm	D2 mm	D3 mm	L1 x L2 mm	L3 mm	€
M2	4,3	2,4	4,3	45 x 12	6	20,75
M3	6,0	3,4	6,0	45 x 18	9	21,09
M4	8,0	4,5	8,0	50 x 22	11	25,04
M5	10,0	5,5	10,0	55 x 26	13	27,89
M6	11,0	6,6	11,0	63 x 30	15	35,05
M8	15,0	9,0	12,5	100 x 34	19	65,80
M10	18,0	11,0	12,5	110 x 42	23	95,83
M12	20,0	14,0	12,5	110 x 34	28	125,86
M14	24,0	16,0	12,5	120 x 42	34	254,60

Réf. BC34

HSSCo 5% **90°**

BC34

	D1 mm	D2 mm	D3 mm	L1 x L2 mm	L3 mm	€
M2	4,6	2,2	4,6	45 x 12	6	20,75
M3	6,5	3,2	6,5	45 x 18	9	21,09
M4	8,6	4,3	8,6	50 x 26	11	25,04
M5	10,4	5,3	10,4	55 x 30	13	27,89
M6	12,4	6,4	12,4	63 x 34	15	35,05
M8	16,4	8,4	12,5	100 x 42	19	65,80
M10	20,4	10,5	12,5	110 x 34	23	95,83
M12	25,0	13,0	12,5	120 x 42	28	254,60

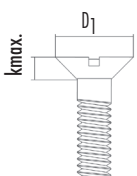

DIN 7991

	M2	M2.5	M3	M4	M5	M6	M8	M10	M12	M14	M16	M18	M20
Kmax.	1,2	1,5	1,7	2,3	2,8	3,3	4,4	5,5	6,5	7	7,5	8	8,5
D1	4	5	6	8	10	12	16	20	24	27	30	33	36

FORETS DIN 345 À QUEUE CONIQUE
**DIN
345**

Pour le perçage de trous supérieurs à 25mm de diamètre, nous recommandons de réaliser un avant-trou d'un tiers du diamètre final à percer.
Exemple: si vous allez utiliser un foret de 30mm, réalisez un avant-trou de 10mm

			BC11	BC22	BC32	BC21	BC13
Ø mm	L1 x L2 mm	CM	€	€	€	€	€
10,75	175 x 94	1	36,81				
11,00	175 x 94	1	33,13	66,56		47,86	89,40
11,25	175 x 94	1	40,45				
11,50	175 x 94	1	35,18	73,79		49,12	89,40
11,75	175 x 94	1	40,46				
12,00	182 x 101	1	35,37	64,61		36,33	93,32
12,25	182 x 101	1	45,05				
12,50	182 x 101	1	37,86	68,12		50,67	93,50
12,75	182 x 101	1	45,06				
13,00	182 x 101	1	39,47	68,07	81,79	51,74	106,46
13,25	189 x 101	1	49,86				
13,50	189 x 101	1	41,64	72,34	98,86	53,38	106,16
13,75	189 x 101	1	49,86				
14,00	189 x 108	1	41,68	76,71	93,97	42,88	115,67
14,25	212 x 114	2	53,99				
14,50	212 x 114	2	46,93	117,54	115,31	71,63	115,65
14,75	212 x 114	2	53,98				
15,00	212 x 114	2	46,93	118,46	109,62	71,63	130,87
15,25	218 x 120	2	55,54				
15,50	218 x 120	2	48,29	124,04	113,14	73,72	139,37
15,75	218 x 120	2	55,54	144,07	141,41		
16,00	218 x 120	2	48,57	123,48	113,14	48,63	139,29
16,25	223 x 125	2	62,79				
16,50	223 x 125	2	54,90	110,64	120,08	75,21	139,72
16,75	223 x 125	2	62,79				
17,00	223 x 125	2	54,88	124,54	120,08	74,83	148,03
17,25	228 x 130	2	69,54				
17,50	228 x 130	2	60,70	134,46	127,01	80,62	147,84
17,75	228 x 130	2	69,54	168,08	169,67		
18,00	228 x 130	2	58,30	128,38	135,76	55,51	160,00
18,25	233 x 135	2	76,46				
18,50	233 x 135	2	66,79	133,80	140,98	82,59	187,02
18,75	233 x 135	2	76,97				
19,00	233 x 135	2	67,02	139,04	140,98	69,50	186,74
19,25	238 x 140	2	83,24				
19,50	238 x 140	2	72,47	143,93	147,90	88,50	209,73
19,75	238 x 140	2	83,80				
20,00	238 x 140	2	72,51	153,92	147,90	73,10	210,22
20,25	243 x 145	2	86,70				
20,50	243 x 145	2	75,15	168,34	172,29	89,84	213,63
20,75	243 x 145	2	86,70				
21,00	243 x 145	2	75,15	182,51	172,29	89,42	213,63
21,25	248 x 150	2	95,69				
21,50	248 x 150	2	82,86	196,75	187,94	94,61	232,90
21,75	248 x 150	2	95,69	245,93	234,95		
22,00	248 x 150	2	83,02	197,91	187,94	85,13	232,90
22,00*	265 x 150	3	112,87				
22,25	248 x 150	2	104,72				
22,50	253 x 155	2	90,85	221,98	198,38	103,02	233,27
22,75	253 x 155	2	104,72				
23,00	253 x 155	2	90,64	216,01	215,79	102,28	253,02
23,25	276 x 155	3	115,50				
23,50	276 x 155	3	100,59	249,76	260,15	123,24	255,32
23,75	281 x 160	3	115,62				
24,00	281 x 160	3	100,38	211,51	240,15	105,10	278,11

	BC11	BC22	BC32	BC21	BC13
MATÉRIEL	HSS	HSSCo 5%	HSSCo 5%	HSS	POINTE CARBURE
AFFÛTAGE					
ANGLE AFFÛTAGE	118°	135°	135°	118°	118°
HÉLICE	30° "N"	30° "N"	38° "N"	30° "N"	30° "N"
FINITION	OX	OX	OX	TiN	BRILLANT
APPLICATION	70 Kg/mm²	120 Kg/mm²	INOX	PRODUCTION	FORTE
Ø mm	L1 x L2	CM	€	€	€
3,00	114 x 33	1	40,02		
3,50	120 x 43	1	39,58		
4,00	124 x 43	1	40,20		
4,50	128 x 47	1	42,78		
5,00	133 x 52	1	25,19		
5,25	133 x 52	1	28,97		
5,50	138 x 57	1	25,19		
5,75	138 x 57	1	28,97		
6,00	138 x 57	1	25,19		
6,25	144 x 63	1	33,02		
6,50	144 x 63	1	26,74		
6,75	150 x 69	1	30,84		
7,00	150 x 69	1	26,64		
7,25	150 x 69	1	35,39		
7,50	150 x 69	1	28,80		
7,75	156 x 75	1	35,39		
8,00	156 x 75	1	28,59		44,71
8,25	156 x 75	1	41,64		
8,50	156 x 75	1	31,10		45,21
8,75	162 x 81	1	37,35		
9,00	162 x 81	1	31,11		45,02
9,25	162 x 81	1	41,16		
9,50	162 x 81	1	30,89		45,02
9,75	168 x 87	1	41,17		
10,00	168 x 87	1	30,21	64,57	44,62 82,82
10,25	168 x 87	1	35,66		
10,50	168 x 87	1	31,95	78,46	46,92 82,34

Cône renforcé, DIN 346, sur demande

FORETS DIN 345 À QUEUE CONIQUE

**DIN
345**



Pour le perçage de trous supérieurs à 25mm de diamètre, nous recommandons de réaliser un avant-trou d'un tiers du diamètre final à percer.
Exemple: si vous allez utiliser un foret de 30mm, réalisez un avant-trou de 10mm

			BC11	BC22	BC32	BC21	BC13								
			€	€	€	€	€	Ø mm	L1 x L2 mm	CM	€	€	€	€	€
MATÉRIEL			HSS	HSSCo 5%	HSSCo 5%	HSS	POINTE CARBURE	31,00	301x180	3	181,55	316,49		197,08	
								31,25	301x180	3	220,91				
AFFÛTAGE								31,50	301x180	3	190,91	486,16			
			118°	135°	135°	118°	118°	31,75	306x185	3	220,91		569,92		
ANGLE AFFÛTAGE								32,00	334x185	4	191,22	485,58	455,92	206,22	531,17*
			30° "N"	30° "N"	38° "N"	30° "N"	30° "N"	32,00	334x185	3	356,12				
HÉLICE								32,25	334x185	4	257,85				
			OX	OX	OX	TIN	BRILLANT	32,50	334x185	4	219,66				
FINITION								32,75	334x185	4	257,85				
			70 Kg/mm²	120 Kg/mm²	INOX	PRODUCTION	FONTE	33,00	334x185	4	218,37	560,38		224,45	653,64*
APPLICATION			€	€	€	€	€	33,25	334x185	4	269,32				
	Ø mm	L1 x L2	CM	€	€	€	€	33,50	334x185	4	238,21				
24,25	281x160	3	125,56					33,75	339x190	4	270,79				
24,50	281x160	3	109,57	262,10	283,58	130,16	279,12	34,00	339x190	4	237,50	619,72		318,95	661,00*
24,75	281x160	3	125,99	438,99				34,25	339x190	4	295,93				
25,00	281x160	3	109,12	229,09	222,75	116,04	285,04	34,50	339x190	4	259,38				
25,25	286x165	3	137,40					34,75	339x190	4	295,93	673,75			
25,50	286x165	3	119,42	329,89	332,57	146,96	338,27	35,00	339x190	4	260,69	663,47	624,68	351,67	
25,75	286x165	3	137,05					35,25	339x190	4	317,16				
26,00	286x165	3	118,73	253,62	281,90	121,90	320,64	35,50	339x190	4	278,27				
26,25	286x165	3	148,39					35,75	344x195	4	325,66				
26,50	286x165	3	128,54	350,20	332,53	152,49	371,68	36,00	344x195	4	278,97	712,81		365,00	1.051,51*
26,75	291x170	3	148,39					36,25	344x195	4	342,31				
27,00	291x170	3	128,65	270,77	302,76	127,72	340,86	36,50	344x195	4	295,03				
27,25	291x170	3	158,81					36,75	344x195	4	342,25				
27,50	291x170	3	137,62	414,70		160,17	409,45	37,00	344x195	4	294,64	653,90		375,65	1.135,72*
27,75	291x170	3	158,81	676,14	667,46			37,25	344x195	4	364,80				
28,00	291x170	3	138,03	291,07	313,25	133,77	377,91	37,50	344x195	4	366,98				
28,25	296x175	3	170,35					37,75	344x195	4	395,77				
28,50	296x175	3	147,56	398,52		168,18	446,12	38,00	349x200	4	309,45	754,64		386,38	
28,75	296x175	3	170,36					38,25	349x200	4	385,50				
29,00	296x175	3	147,54	298,90	341,08	152,93	402,27	38,50	349x200	4	329,29				
29,25	296x175	3	187,32					38,75	349x200	4	385,50				
29,50	296x175	3	162,48	407,57		200,80	486,62	39,00	349x200	4	329,55	772,20		400,86	1.255,87*
29,75	296x175	3	187,32	674,14	651,41			39,25	349x200	4	387,76				
30,00	296x175	3	162,56	318,26	358,45	158,81	427,59	39,50	349x200	4	349,03				
30,25	301x180	3	208,52					39,75	349x200	4	387,76				
30,50	301x180	3	181,37	468,51				40,00	349x200	4	348,58	809,21		413,87	1.295,52*
30,75	301x180	3	208,63					40,50	354x205	4	365,40				
								41,00	354x205	4	365,85	850,65			
								41,50	354x205	4	388,88				
								42,00	354x205	4	388,09	890,67			
								42,50	354x205	4	407,85				
								43,00	359x210	4	407,86	933,92			
								43,50	359x210	4	427,03				
								44,00	359x210	4	427,29	969,76			
								44,50	359x210	4	446,86				
								45,00	359x210	4	447,21	1.014,14			
								45,50	364x215	4	464,68				
								46,00	364x215	4	462,73				
								46,50	364x215	4	483,66				
								47,00	364x215	4	483,42	1.095,79			
								47,50	364x215	4	499,89				
								48,00	369x220	4	499,54	1.141,71			
								48,50	369x220	4	519,73				

Cône renforcé, DIN 346, sur demande

*Jusqu'à fin de stock

FORETS DIN 345 À QUEUE CONIQUE

Réf. BC11

DIN
345
HSS

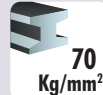
OX

70
Kg/mm²

Forets pour métaux

Gris



BC11				
Ø mm	L1 x L2 mm	CM	€	
49,00	369x220	4	517,53	
49,50	369x220	4	533,83	
50,00	369x220	4	539,55	
50,50	369x220	4	772,58	
51,00	412x225	5	632,69	
51,50	412x225	5	848,00	
52,00	412x225	5	676,18	
52,50	412x225	5	868,64	
53,00	412x225	5	724,19	
53,50	412x225	5	908,66	
54,00	417x230	5	796,91	
54,50	417x230	5	899,56	
55,00	417x230	5	788,91	
56,00	417x230	5	887,70	
57,00	422x235	5	943,02	
58,00	422x235	5	951,07	
59,00	422x235	5	979,63	
60,00	422x235	5	927,34	
61,00	427x240	5	1.087,74	
62,00	427x240	5	1.132,91	
63,00	427x240	5	1.198,10	
64,00	432x245	5	1.264,09	
65,00	432x245	5	1.210,36	
66,00	432x245	5	1.364,63	
67,00	432x245	5	1.408,63	
68,00	437x250	5	1.445,16	
69,00	437x250	5	1.490,11	
70,00	437x250	5	1.345,57	
71,00	437x250	5	1.553,50	
72,00	442x255	5	1.585,68	
73,00	442x255	5	1.627,18	
74,00	442x255	5	1.674,80	
75,00	442x255	5	1.577,61	
76,00	447x260	5	1.857,64	
77,00	514x260	6	1.993,47	
78,00	514x260	6	2.032,42	
79,00	514x260	6	2.073,37	
80,00	514x260	6	2.609,71	
81,00	519x265	6	2.887,90	
82,00	519x265	6	2.960,05	
83,00	519x265	6	3.016,83	
84,00	519x265	6	3.080,87	
85,00	519x265	6	3.156,97	
86,00	524x270	6	3.225,89	
87,00	524x270	6	3.294,41	
88,00	524x270	6	3.379,08	
89,00	524x270	6	3.444,49	
90,00	524x270	6	3.543,07	
91,00	529x275	6	3.736,90	
92,00	529x275	6	3.758,44	
93,00	529x275	6	3.892,47	
94,00	529x275	6	3.971,56	
95,00	529x275	6	4.053,18	
96,00	534x280	6	4.186,70	
97,00	534x280	6	4.221,82	
98,00	534x280	6	4.315,99	
99,00	534x280	6	4.394,05	
100,00	534x280	6	4.477,87	



Réf. EXPBC11MC

PRÉSENTOIR POUR 15 FORETS QUEUE CONIQUE

Cône Morse	14	15	16	17	18	DIN
n° 1	1	1	1	1	1	345
n° 2	19	20	21	22	23	
	1	1	1	1	1	
n° 3	24	25	26	28	30	
	1	1	1	1	1	

Dimensions: Largeur 280 x profondeur 212/50 x hauteur 155 mm.

1.267,52 €
SUPPLÉMENT POUR RÉDUCTION DU CÔNE MORSE

n° 2-1

n° 2-0

n° 3-2

n° 3-1

n° 4-3

n° 4-2

€ NET

53,30

79,95

Cône renforcé, DIN 346, sur demande

Longueur maximale du foret 370mm pour pouvoir effectuer une réduction de cône morse

FORETS CÔNE MORSE M42 (8% COBALT) POUR PERCER LES MATÉRIAUX DURS ET RÉSISTANTS

Réf. BC73

HSSCo
8%



OX

HARDOX
450

BC73

	D1 mm	L1 mm	L2 mm	CM	€
BC731000	10,00	175	76	2	59,19
BC731020	10,20	175	76	2	59,19
BC731100	11,00	175	76	2	59,19
BC731200	12,00	179	81	2	64,83
BC731250	12,50	179	81	2	64,83
BC731300	13,00	179	81	2	64,83
BC731400	14,00	184	86	2	69,01
BC731450	14,50	187	89	2	69,92
BC731500	15,00	187	89	2	70,37
BC731550	15,50	187	89	2	79,93
BC731600	16,00	187	89	2	83,73
BC731650	16,50	190	92	2	87,59
BC731700	17,00	190	92	2	89,25
BC731800	18,00	190	92	2	90,59
BC731850	18,50	213	95	3	100,97
BC731900	19,00	213	95	3	102,94
BC732000	20,00	213	95	3	109,44
BC732100	21,00	219	102	3	119,18
BC732200	22,00	222	105	3	137,01
BC732400	24,00	222	105	3	147,61
BC732500	25,00	225	108	3	174,91
BC732600	26,00	270	124	4	207,25
BC732700	27,00	270	124	4	214,55
BC732800	28,00	270	124	4	220,63
BC733000	30,00	270	124	4	235,78
BC733200	32,00	280	133	4	299,62
BC733500	35,00	292	136	4	374,36
BC733600	36,00	292	146	4	393,73
BC734000	40,00	298	152	4	481,22
BC734500	45,00	298	152	4	654,48
BC735000	50,00	356	152	5	768,86
BC735500	55,00	360	156	5	913,46
BC736000	60,00	360	156	5	1.114,81

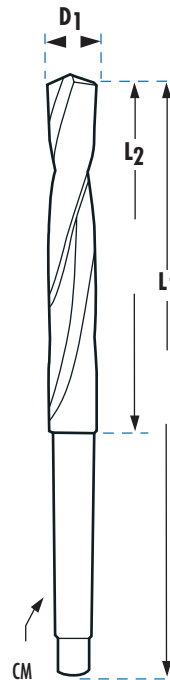

Foret spécial pour HARDOX 450



Pour le perçage de trous supérieurs à 25mm de diamètre, nous recommandons de réaliser un avant-trou d'un tiers du diamètre final à percer.
Exemple: si vous allez utiliser un foret de 30mm, réalisez un avant-trou de 10mm

Réf. BC22...FT

DIN
345

HSSCo
5%

TiN



HARDOX
450

BC22...FT

	D1 mm	L1 mm	L2 mm	CM	€
BC221600FT	16,00	218	120	2	101,49
BC221800FT	18,00	228	130	2	110,41
BC222000FT	20,00	238	140	2	132,36
BC222200FT	22,00	248	150	2	156,62
BC222400FT	24,00	281	160	3	196,36
BC222500FT	25,00	281	160	3	205,71
BC222600FT	26,00	286	165	3	243,17
BC222800FT	28,00	291	170	3	299,00
BC223000FT	30,00	296	175	3	295,47
BC223200FT	32,00	334	185	4	334,32
BC223400FT	34,00	339	190	4	430,66
BC223600FT	36,00	344	195	4	486,18



- La meilleure solution pour le perçage de trous de grand diamètre dans des matières à la dureté élevée.
- Affûtage spécial matières très dures, avec coupe corrigée.



Ce foret a historiquement été utilisé pour le perçage de rails de voie ferrée

Foret spécial pour HARDOX 450

FORETS À QUEUE CONIQUE SÉRIE LONGUE
**DIN
341**

Réf. BC12



Réf. BC56



		BC12		BC56				BC12		BC56	
MATÉRIEL		HSS		HSSCo 5%							
AFFÛTAGE											
ANGLE AFFÛTAGE		118°		135°							
HÉLICE											
FINITION		OX		OX							
APPLICATION											
Ø mm	L1 x L2	CM	€	€	€	€	Ø mm	L1 x L2	CM	€	€
5,00	155x74	1	24,34				27,00	343x222	3	154,26	375,40
5,50	161x80	1	32,63				27,50	343x222	3	198,80	
6,00	161x80	1	25,87				28,00	343x222	3	176,07	386,46
6,50	167x86	1	26,43				28,50	351x230	3	235,94	
7,00	174x93	1	28,06				29,00	351x230	3	192,82	419,60
7,50	174x93	1	29,51				29,50	351x230	3	236,15	
8,00	181x100	1	30,02				30,00	351x230	3	197,74	441,66
8,50	181x100	1	30,02				30,50	360x239	3	269,99	
9,00	188x107	1	33,12				31,00	360x239	3	249,73	496,88
9,50	188x107	1	36,24				31,50	360x239	3	289,66	
10,00	197x116	1	37,31	78,66			32,00	397x248	4	250,71	552,10
10,25	197x116	1	44,65				32,50	397x248	4	317,40	
10,50	197x116	1	38,80				33,00	397x248	4	267,17	
10,75	206x125	1	56,90				33,50	397x248	4	313,38	
11,00	206x125	1	37,31	86,13			34,00	406x257	4	325,19	
11,25	206x125	1	56,90				34,50	406x257	4	344,35	
11,50	206x125	1	37,31				35,00	406x257	4	327,16	
11,75	206x125	1	51,35				35,50	406x257	4	344,35	
12,00	215x134	1	39,90	96,86			36,00	416x267	4	376,44	
12,25	215x134	1	51,35				36,50	416x267	4	476,40	
12,50	215x134	1	40,93				37,00	416x267	4	405,45	
12,75	215x134	1	55,09				37,50	416x267	4	472,08	
13,00	215x134	1	40,93	101,33			38,00	426x277	4	424,48	
13,25	223x142	1	57,44				38,50	426x277	4	538,11	
13,50	223x142	1	44,61				39,00	426x277	4	441,02	
13,75	223x142	1	62,05				39,50	426x277	4	538,11	
							40,00	426x277	4	476,98	
							41,00	436x287	4	609,88	
							42,00	436x287	4	636,12	
							43,00	447x298	4	677,01	
							44,00	447x298	4	687,33	
							45,00	447x298	4	724,41	
							46,00	459x310	4	762,23	
							47,00	459x310	4	802,21	
							48,00	470x321	4	838,52	
							49,00	470x321	4	865,93	
							50,00	470x321	4	896,50	
							55,00	505x310	5	1.172,26	

FORETS À QUEUE CONIQUE SÉRIE EXTRA-LONGUE

Forets pour métaux
Rose

DIN
1870
I/II

Réf. BC14



Réf. BC41



MATÉRIEL	BC14		BC41		BC14		BC41		BC14		BC41	
	HSS	HSSCo 5%	Ø mm	L1 x L2	CM	€	€	Ø mm	L1 x L2	CM	€	€
AFFÛTAGE			17,00	355x230	2	176,40	279,62	29,00	460x305	3	412,09	868,33
ANGLE AFFÛTAGE	118°	135°	17,00	445x295	2	212,10	390,87	29,00	580x385	3	590,85	1.178,68
HÉLICE	30° "N"	38° "S"	17,50	370x245	2	194,11	314,51	29,50	460x305	3	426,65	994,10
FINITION	OX	BRILLANT	17,50	465x310	2	233,55	425,31	29,50	580x385	3	595,73	1.371,82
APPLICATION	70 Kg/mm²	120 Kg/mm²	18,00	370x245	2	194,11	306,05	30,00	460x305	3	426,65	908,46
			18,00	465x310	2	233,55	403,34	30,00	580x385	3	595,73	1.225,33
			18,50	370x245	2	205,99	353,65	31,00	480x320	4	478,25	1.149,76
			18,50	465x310	2	252,41	482,59	31,00	610x410	4	635,13	
			19,00	370x245	2	208,24	352,83	32,00	505x320	4	500,03	
			19,00	465x310	2	252,41	450,48	32,00	635x410	4	666,40	
			19,50	385x260	2	222,38	394,58	33,00	505x320	4	544,88	
			19,50	490x325	2	273,15	505,28	33,00	635x410	4	737,74	
			20,00	385x260	2	224,74	387,66	34,00	530x340	4	590,80	
			20,00	490x325	2	273,15	505,02	34,00	665x430	4	785,43	
			20,50	385x260	2	254,52	515,97	35,00	530x340	4	608,52	
			20,50	490x325	2	305,63	594,13	35,00	665x430	4	831,88	
			21,00	385x260	2	254,52	473,89	36,00	530x340	4	656,50	
			21,00	490x325	2	305,63	588,72	36,00	665x430	4	873,50	
			21,50	405x270	2	271,43	558,14	37,00	530x340	4	673,11	
			21,50	515x345	2	328,00	697,19	37,00	665x430	4	970,55	
			22,00	405x270	2	271,43	506,11	38,00	555x360	4	734,26	
			22,00	515x345	2	328,00	679,64	38,00	695x460	4	1.027,75	
			22,50	405x270	2	309,32	594,13	39,00	555x360	4	765,24	
			22,50	515x345	2	370,27	737,87	39,00	695x460	4	1.076,78	
			23,00	405x270	2	309,32	579,44	40,00	555x360	4	806,72	
			23,00	515x345	2	370,27	697,19	40,00	695x460	4	1.027,10	
			23,50	425x270	3	339,83	726,11	41,00	555x360	4	933,14	
			23,50	535x345	3	412,09	885,62	41,00	695x460	4	1.167,41	
			24,00	440x290	3	339,83	663,02	42,00	555x360	4	963,88	
			24,00	555x365	3	412,09	811,31	42,00	695x460	4	1.246,46	
			24,50	440x290	3	352,21	783,40	43,00	585x385	4	1.005,15	
			24,50	555x365	3	434,29	931,14	43,00	735x490	4	1.271,83	
			25,00	440x290	3	352,21	698,73	44,00	585x385	4	1.067,76	
			25,00	555x365	3	434,29	832,79	44,00	735x490	4	1.316,53	
			25,50	440x290	3	364,02	833,61	45,00	585x385	4	1.084,26	
			25,50	555x365	3	479,74	1.085,57	45,00	735x490	4	1.377,87	
			26,00	440x290	3	364,02	755,45	46,00	585x385	4	1.117,41	
			26,00	555x365	3	479,74	976,82	46,00	735x490	4	1.439,46	
			26,50	440x290	3	372,78	846,48	47,00	585x385	4	1.152,26	
			26,50	555x365	3	495,00	1.165,52	47,00	735x490	4	1.510,12	
			27,00	460x305	3	372,78	785,18	48,00	605x405	4	1.211,02	
			27,00	580x385	3	495,00	1.033,97	48,00	765x510	4	1.597,94	
			27,50	460x305	3	397,67	920,92	49,00	605x405	4	1.247,90	
			27,50	580x385	3	535,46	1.234,17	49,00	765x510	4	1.658,78	
			28,00	460x305	3	397,67	831,82	50,00	605x405	4	1.284,63	
			28,00	580x385	3	535,46	1.123,62	50,00	765x510	4	1.702,13	
			28,50	460x305	3	412,09	977,10					
			28,50	580x385	3	590,85	1.285,35					

FORETS À QUEUE CONIQUE DIN 341 À TROUS D'HUILE

Réf. BC87

 $\leq 10xD$
**DIN
341**
HSS

170°

OX

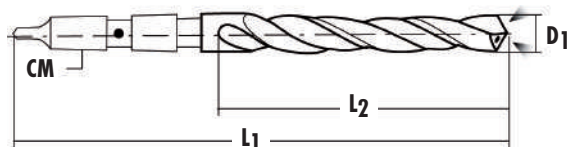
**AFFÛTAGE À 170°
POINTE PILOTE
CENTRAGE PRÉCIS**

BC87					
	D1 mm	L1 mm	L2 mm	CM	€
BC871000	10,0	268	116	3	441,31
BC871050	10,5	268	116	3	447,38
BC871100	11,0	278	125	3	447,38
BC871200	12,0	287	134	3	457,17
BC871300	13,0	287	134	3	457,17
BC871350	13,5	285	142	3	457,17
BC871400	14,0	285	142	3	457,17
BC871450	14,5	245	147	2	472,75*
BC871500	15,0	300	147	3	472,75
BC871550	15,5	251	153	2	488,63*
BC871600	16,0	306	153	3	488,63
BC871650	16,5	257	159	2	488,63*
BC871700	17,0	311	159	3	488,63
BC871750	17,5	318	165	3	519,76
BC871800	18,0	318	165	3	519,76
BC871900	19,0	324	171	3	535,74
BC872000	20,0	330	177	3	567,18
BC872100	21,0	343	184	3	598,90
BC872200	22,0	350	191	3	636,40

BC87					
	D1 mm	L1 mm	L2 mm	CM	€
BC872300	23,0	357	198	3	630,33
BC872400	24,0	365	206	3	630,33
BC872500	25,0	365	206	3	643,36
BC872600	26,0	373	214	3	709,32
BC872700	27,0	375	222	4	740,77
BC872800	28,0	375	222	4	813,01
BC872900	29,0	375	230	4	867,04
BC873000	30,0	375	230	4	926,74
BC873100	31,0	375	239	4	1.103,19
BC873200	32,0	375	248	4	1.103,19
BC873300	33,0	375	248	4	1.289,05
BC873400	34,0	375	257	4	1.289,05
BC873500	35,0	375	257	4	1.449,68
BC873600	36,0	375	257	4	1.449,68
BC873700	37,0	375	257	4	1.638,80
BC873800	38,0	375	277	4	1.638,80
BC873900	39,0	375	277	4	1.828,09
BC874000	40,0	375	277	4	1.828,09

*Jusqu'à fin de stock

FORETS TAILLÉS - MEULÉS EN COFFRETS MÉTALLIQUE ET PLASTIQUE



Réf. PT6010

Plastique Bleu

- Rigide, Robuste et Léger
- Fenêtre transparente
- ABS renforcé avec protection anti-chocs

P Les références commençant par la lettre "P" sont livrés en coffret plastique.

Réf. P6011



Réf. PP6010

Métal Classique

- Coffret métallique haute résistance

M



Réf. DC011



Réf. DC010

Réf. BC2



Réf. BC02



BC2		Réf.	U.		CONTENU	€
DIN 338	HSS	D0010	19	M	Ø 1-10 x 0,50 mm	64,45
		D0011	25	M	Ø 1-13 x 0,50 mm	134,10
118°	118°	P6010	19	P	Ø 1-10 x 0,50 mm	64,45
		P6011	25	P	Ø 1-13 x 0,50 mm	134,10
Quarts		AD001	37	M	Ø 1-10 x 0,25 mm	175,59
		AD002	49	M	Ø 1-13 x 0,25 mm	315,16
Dixièmes		D0014	50	M	Ø 1-5,90 x 0,10 mm	121,97
		D0015	41	M	Ø 6-10 x 0,10 mm	316,98
		D0022	81	M	Ø 2-10 x 0,10 mm	548,85
Demis + Avant-trous		D0017	23	M	Ø 1-10 x 0,50 + Ø AT*	122,85
		D0035	29	M	Ø 1-13 x 0,50 + Ø AT*	203,06
Compositions Supplémentaires		D0007	10	M	Ø 1-10 x 1 mm	52,45
		D0009	13	M	Ø 1,5-6,5x0,5 (+3,2 & 4,8) mm	24,91
		D0008	13	M	Ø 1-7 x 0,50 mm	25,91
		D0006	12	M	Ø 2-7 x 0,50 + 8 mm	47,56

BC02		Réf.	U.		CONTENU	€
DIN 338	Plus	DP010	19	M	Ø 1-10 x 0,50 mm	72,86
		DP011	25	M	Ø 1-13 x 0,50 mm	150,73
118°	118°	PP6010	19	P	Ø 1-10 x 0,50 mm	72,86
		PP6011	25	P	Ø 1-13 x 0,50 mm	150,73
Quarts		ADP01	37	M	Ø 1-10 x 0,25 mm	210,32
		ADP02	49	M	Ø 1-13 x 0,25 mm	374,23
Dixièmes		Sur commande	50	M	Ø 1-5,90 x 0,10 mm	
		Sur commande	41	M	Ø 6-10 x 0,10 mm	
		Sur commande	81	M	Ø 2-10 x 0,10 mm	
Demis + Avant-trous		DP017	23	M	Ø 1-10 x 0,50 + Ø AT*	122,96
		DP035	29	M	Ø 1-13 x 0,50 + Ø AT*	210,90
Compositions Supplémentaires		DP007	10	M	Ø 1-10 x 1 mm	68,78
		DP009	13	M	Ø 1,5-6,5x0,5 (+3,2 & 4,8) mm	29,24
		DP008	13	M	Ø 1-7 x 0,50 mm	29,25
		DP006	12	M	Ø 2-7 x 0,50 + 8 mm	49,22

Réf. BC5



Réf. BC18



BC5		Réf.	U.		CONTENU	€
DIN 338	HSSCo 5%	DC010	19	M	Ø 1-10 x 0,50 mm	107,70
		DC011	25	M	Ø 1-13 x 0,50 mm	252,58
135°	135°	PC6010	19	P	Ø 1-10 x 0,50 mm	107,70
		PC6011	25	P	Ø 1-13 x 0,50 mm	252,58
Quarts		ADC01	37	M	Ø 1-10 x 0,25 mm	253,93
		ADC02	49	M	Ø 1-13 x 0,25 mm	568,32
Dixièmes		DC014	50	M	Ø 1-5,90 x 0,10 mm	185,00
		DC015	41	M	Ø 6-10 x 0,10 mm	470,37
		DC022	81	M	Ø 2-10 x 0,10 mm	750,64
Demis + Avant-trous		DC017	23	M	Ø 1-10 x 0,50 + Ø AT*	172,42
		DC035	29	M	Ø 1-13 x 0,50 + Ø AT*	330,30
Compositions Supplémentaires		DC007	10	M	Ø 1-10 x 1 mm	89,61
		DC009	13	M	Ø 1,5-6,5x0,5 (+3,2 & 4,8) mm	43,64
		DC008	13	M	Ø 1-7 x 0,50 mm	45,72
		DC006	12	M	Ø 2-7 x 0,50 + 8 mm	68,54

BC18		Réf.	U.		CONTENU	€
HSS	TIN	DT010	19	M	Ø 1-10 x 0,50 mm	92,45
		DT011	25	M	Ø 1-13 x 0,50 mm	194,60
118°	118°	PT6010	19	P	Ø 1-10 x 0,50 mm	92,45
		PT6011	25	P	Ø 1-13 x 0,50 mm	194,60
Quarts		ADT01	37	M	Ø 1-10 x 0,25 mm	214,14
		ADT02	49	M	Ø 1-13 x 0,25 mm	429,47
Dixièmes		Sur commande	50	M	Ø 1-5,90 x 0,10 mm	
		Sur commande	41	M	Ø 6-10 x 0,10 mm	
		Sur commande	81	M	Ø 2-10 x 0,10 mm	
Demis + Avant-trous		Sur commande	23	M	Ø 1-10 x 0,50 + Ø AT*	
		Sur commande	29	M	Ø 1-13 x 0,50 + Ø AT*	
Compositions Supplémentaires		DT007	10	M	Ø 1-10 x 1 mm	72,94
		DT009	13	M	Ø 1,5-6,5x0,5 (+3,2 & 4,8) mm	36,77
		DT008	13	M	Ø 1-7 x 0,50 mm	39,89
		DT006	12	M	Ø 2-7 x 0,50 + 8 mm	59,71

* AT (Avant-Trous): de M3 à M12 (Ø3,30 - Ø4,20 - Ø6,80 - Ø10,20)

FORETS TAILLÉS - MEULÉS EN COFFRETS MÉTALLIQUE ET PLASTIQUE

Forets pour métaux

Gris

Rose

Métal Classique

- Coffret métallique haute résistance

M
Plastique Bleu

- Rigide, Robuste et Léger
- Fenêtre transparente
- ABS renforcé avec protection anti-chocs

P

Les références commençant par la lettre "P" sont livrées en coffret plastique.



Réf. PTTX011

Réf. BC95



Réf. BC58



BC95		Réf.	U.		CONTENU	€
HSSCo 5%		DC9510	19	M	Ø 1-10 x 0,50 mm	122,78
		DC9511	25	M	Ø 1-13 x 0,50 mm	277,53
		PC9510	19	P	Ø 1-10 x 0,50 mm	122,78
		PC9511	25	P	Ø 1-13 x 0,50 mm	277,53

BC58		Réf.	U.		CONTENU	€
DIN 338	HSSCo 8%	DC810	19	M	Ø 1-10 x 0,50 mm	155,83
		DC811	25	M	Ø 1-13 x 0,50 mm	367,65
		ADC81	37	M	Ø 1-10 x 0,25 mm	359,11
		ADC82	49	M	Ø 1-13 x 0,25 mm	842,65

Réf. BC82



BC82		Réf.	U.		CONTENU	€
DIN 338	HSS	D8210	19	M	Ø 1-10 x 0,50 mm	64,45
		D8211	25	M	Ø 1-13 x 0,50 mm	134,10

Quarts		Réf.	U.		CONTENU	€
Demis + Avant-trous		DC817	23	M	Ø 1-10 x 0,50 + Ø AT*	231,26
		DC835	29	M	Ø 1-10 x 0,50 + Ø AT*	454,71
Compositions Supplémentaires		DC806	12	M	Ø 2-7 x 0,50 + 8 mm	90,32
		DC807	10	M	Ø 1-10 x 1 mm	113,51

Réf. BTX



BTX		Réf.	U.		CONTENU	€
Ø ≥ 3	HSSCo 5%	PTX010	19	P	Ø 1-10 x 0,50 mm	98,88
		PTX011	25	P	Ø 1-13 x 0,50 mm	245,02

Réf. TTX



TTX		Réf.	U.		CONTENU	€
Ø ≥ 3	HSS	PTTX010	19	P	Ø 1-10 x 0,50 mm	88,98
		PTTX011	25	P	Ø 1-13 x 0,50 mm	220,51
	TiAlSiN					

Réf. TK02



TK02		Réf.	U.		CONTENU	€
DIN 338	HSS	TK02010	19	P	Ø 1-10 x 0,50 mm	198,38
Ø ≥ 4		TK02011	25	P	Ø 1-13 x 0,50 mm	353,91

Réf. TK05



TK05		Réf.	U.		CONTENU	€
DIN 338	HSSCo 5%	TK05010	19	P	Ø 1-10 x 0,50 mm	247,97
Ø ≥ 5		TK05011	25	P	Ø 1-13 x 0,50 mm	442,39

FORETS EN COFFRET MÉTALLIQUE (compositions spéciales)

FORETS HSS POUR ALUMINIUM

Réf. BC16



BC16		Réf.	U.		CONTENU	€
DIN 338	HSS	D16010	19	M	Ø 1-10 x 0,50 mm	102,04
		D16011	25	M	Ø 1-13 x 0,50 mm	223,88

FORETS HSSCo GÉOMÉTRIE TYPE "S"

Réf. BC55



BC55		Réf.	U.		CONTENU	€
DIN 338	HSSCo 5%	D55010	18	M	Ø 1,50-10 x 0,50 mm	199,46
		D55011	24	M	Ø 1,50-13 x 0,50 mm	404,22

FORETS POINTE CARBURE POUR FONTE, ETC

Réf. BC7



BC7		Réf.	U.		CONTENU	€
DIN 338	POINTE CARBURE	DPMD010	17	M	Ø 2-10 x 0,50 mm	381,49
		DPMD011	23	M	Ø 2-13 x 0,50 mm	668,96

FORETS CARBURE MONOBLOC POUR MATÉRIAUX TRÈS DURS

Réf. BC42



BC42		Réf.	U.		CONTENU	€
DIN 338	CARBURE	D42010	17	M	Ø 2-10 x 0,50 mm	1.072,96
		D42011	23	M	Ø 2-13 x 0,50 mm	2.404,73

FORETS POUR ACIER INOX

Réf. BC50



BC50		Réf.	U.		CONTENU	€
DIN 338	HSSCo 5%	D50010	19	M	Ø 1-10 x 0,50 mm	317,20
		D50011	25	M	Ø 1-13 x 0,50 mm	479,35

FORETS COUPE À GAUCHE

Réf. BC15



BC15		Réf.	U.		CONTENU	€
DIN 338	HSS	D0010I	19	M	Ø 1-10 x 0,50 mm	163,04
		D0011I	25	M	Ø 1-13 x 0,50 mm	327,50
		DR9312I	10	P	Ø 1-10 x 1 mm	79,76

COFFRETS VIDES

Réf.	U.		CONTENU	€
D0010V	19	M	Ø 1-10 x 0,50 mm	19,98
D0011V	25	M	Ø 1-13 x 0,50 mm	27,87
AD001V	37	M	Ø 1-10 x 0,25 mm	73,21
AD002V	49	M	Ø 1-13 x 0,25 mm	85,04
D0014V	50	M	Ø 1-5,9 x 0,10 mm	64,85
D0015V	41	M	Ø 6-10 x 0,10 mm	129,56
D0022V	81	M	Ø 2-10 x 0,10 mm	248,50
D0006V	12	M	Ø 2-7 x 0,50 + 8 mm	27,11
D0007V	10	M	Ø 1-10 x 1 mm	46,51
D0017V	23	M	Ø 1-10 x 0,50 mm + AT*	53,95
D0035V	29	M	Ø 1-13 x 0,50 mm + AT*	76,30
DE10V	19	M	Ø 1-10 x 0,50 mm	47,18
DE11V	25	M	Ø 1-13 x 0,50 mm	57,65

DIN 1897



* AT (Avant-Trous): de M3 à M12 (Ø3,30 - Ø4,20 - Ø6,80 - Ø10,20)

FORETS TAILLÉS - MEULÉS EN COFFRET MÉTALLIQUE
FORETS SÉRIE LONGUE DIN 340

Réf. BC4



BC4		Réf.	U.	CONTENU	€	
DIN 340	HSS	D0004	19	M	Ø 1-10 x 0,50 mm	105,48

Réf. BC47



BC47		Réf.	U.	CONTENU	€	
DIN 340	HSSCo 5%	DC004	x17	M	Ø 2-10 x 0,50 mm	226,44

Réf. BC40



BC40		Réf.	U.	CONTENU	€	
HSS	TiN	DT004	19	M	Ø 1-10 x 0,50 mm	163,92

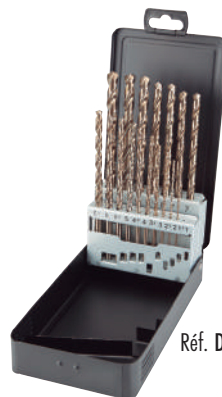

Réf. DC004



Réf. DT004

FORETS SÉRIE EXTRA-COURTE DIN 1897

Réf. BC3



BC3		Réf.	U.	CONTENU	€	
DIN 1897	HSS	D3010	19	M	Ø 1-10 x 0,50 mm	74,88
		D3011	25	M	Ø 1-13 x 0,50 mm	120,28

Réf. BC31



BC31		Réf.	U.	CONTENU	€	
DIN 1897	HSSCo 5%	D3110	19	M	Ø 1-10 x 0,50 mm	108,14
		D3111	25	M	Ø 1-13 x 0,50 mm	226,35

Réf. BC33



BC33		Réf.	U.	CONTENU	€	
DIN 1897	HSSCo 5%	D3310	19	M	Ø 1-10 x 0,50 mm	162,18
		D3311	25	M	Ø 1-13 x 0,50 mm	271,50

Réf. BC77



BC77		Réf.	U.	CONTENU	€	
DIN 1897	POINTE CARBURE	D7710	17	M	Ø 2-10 x 0,50 mm	404,75
		D7711	23	M	Ø 2-13 x 0,50 mm	638,23

Réf. BC43



BC43		Réf.	U.	CONTENU	€	
DIN 1897	CARBURE	D4310	17	M	Ø 2-10 x 0,50 mm	695,45
		D4311	23	M	Ø 2-13 x 0,50 mm	1.464,84



Réf. D7710



Réf. D3110

FORETS TAILLÉS - MEULÉS EN COFFRET PLASTIQUE

Forets pour métaux

Rose Gris



Réf. DP9314



Réf. DP9312



Réf. DP9313



Réf. DP9311

Réf. BC2



BC2		Réf.	U.	CONTENU	€
DIN 338	HSS	DR9314	6	Ø 2 - 3 - 4 - 5 - 6 - 8 mm	18,75
		DR9312	10	Ø 1-10 x 1 mm	39,93
		DR9313	13	Ø 2-8 x 0,50 mm	39,62
		DR9311	19	Ø 1-10 x 0,50 mm	69,76

Réf. BC02



BC02		Réf.	U.	CONTENU	€
DIN 338	Plus	DP9314	6	Ø 2 - 3 - 4 - 5 - 6 - 8 mm	19,77
		DP9312	10	Ø 1-10 x 1 mm	43,20
		DP9313	13	Ø 2-8 x 0,50 mm	42,25
		DP9311	19	Ø 1-10 x 0,50 mm	76,19

Réf. BC5



BC5		Réf.	U.	CONTENU	€
DIN 338	HSSCo 5%	DC9314	6	Ø 2 - 3 - 4 - 5 - 6 - 8 mm	29,81
		DC9312	10	Ø 1-10 x 1 mm	63,94
		DC9313	13	Ø 2-8 x 0,50 mm	64,40
		DC9311	19	Ø 1-10 x 0,50 mm	114,28

Réf. BC18



BC18		Réf.	U.	CONTENU	€
HSS	TiN	DT9314	6	Ø 2 - 3 - 4 - 5 - 6 - 8 mm	19,88
		DT9312	10	Ø 1-10 x 1 mm	42,25
		DT9313	13	Ø 2-8 x 0,50 mm	40,82
		DT9311	19	Ø 1-10 x 0,50 mm	73,73

Réf. BC82



BC82		Réf.	U.	CONTENU	€
DIN 338	HSS	D829314	6	Ø 2 - 3 - 4 - 5 - 6 - 8 mm	17,75
		D829312	10	Ø 1-10 x 1 mm	37,79
		D829313	13	Ø 2-8 x 0,50 mm	37,50
		D829311	19	Ø 1-10 x 0,50 mm	66,02

Réf. BC58



BC58		Réf.	U.	CONTENU	€
DIN 338	HSSCo 8%	D89314	6	Ø 2 - 3 - 4 - 5 - 6 - 8 mm	38,04
		D89312	10	Ø 1-10 x 1 mm	81,36
		D89313	13	Ø 2-8 x 0,50 mm	83,38
		D89311	19	Ø 1-10 x 0,50 mm	146,26

				Réf.	U.	CONTENU	€
BC95	HSSCo 5%	OX DORÉ		DC959314	6	Ø 2-3-4-5-6-8 mm	29,92
BTX	Ø ≥ 3	HSSCo 5%		PTX9314	6	Ø 2-3-4-5-6-8 mm	30,07
TTX	Ø ≥ 3	HSS		PTTX9314	6	Ø 2-3-4-5-6-8 mm	27,97
TK02	DIN 338	HSS		PTK029314	6	Ø 2-3-4-5-6-8 mm	48,83
TK05	DIN 338	HSSCo 5%		PTK059314	6	Ø 2-3-4-5-6-8 mm	61,04

Réf. BC95



Réf. BTX



Réf. TTX



Réf. TK02



Réf. TK05



FORETS TAILLÉS - MEULÉS EN COFFRET PLASTIQUE
FORETS EN DISTRIBUTEUR PLASTIQUE ROND 19 PCS

					Réf.	U.	CONTENU	€
BC2	DIN 338	HSS	118°		DR9380	19	Ø 1-10 x 0,50 mm	65,43
BC02	DIN 338	Plus	118°		DP9380	19	Ø 1-10 x 0,50 mm	73,25
BC5	DIN 338	HSSCo 5%	135°		DC9380	19	Ø 1-10 x 0,50 mm	109,08
BC18	TiN	HSS	118°		DT9380	19	Ø 1-10 x 0,50 mm	94,26
BC58	DIN 338	HSSCo 8%	135°		D89380	19	Ø 1-10 x 0,50 mm	148,35

Réf. BC2



Réf. BC02



Réf. BC5



Réf. BC18



Réf. BC58

MICRO-FORETS EN COFFRET PLASTIQUE POUR AÉROMODÉLISME ET MARQUETERIE

Réf. DC9120



Réf. DR9102



			Réf.	U.	CONTENU	€
DR9120	DIN 338	HSS	DR9120	10	Ø 1-1,90 x 0,10 mm	25,16
DC9120	DIN 338	HSSCo 5%	DC9120	10	Ø 1-1,90 x 0,10 mm	35,83
DR9102	DIN 338	HSS	DR9102	15	Ø 0,30 - 0,35 - 0,40 - 0,45 - 0,50 - 0,55 - 0,60 - 0,65 - 0,70 - 0,75 - 0,80 - 0,85 - 0,90 - 0,95 - 1	48,52

ASSORTIMENTS DE FORETS EN COFFRET PLASTIQUE: HSS, BÉTON ET BOIS

SÉRIE STANDARD

HSS		(Réf. BC2)	  			
POINTE CARBURE		(Réf. BW1)				
CV		(Réf. BM)				
RÉFÉRENCE	EC9330		EC9331		EC9332	
QUANTITÉ	8		9		9	
QUALITÉ	 		  		  	
CONTENU	Ø 4 - 5 - 6 - 8 mm x 2		Ø 4 - 6 - 8 mm x 3		Ø 5 - 6 - 8 mm x 3	
PRIX €	21,70		24,72		25,19	

*Jusqu'à fin de stock

SÉRIE PROFESSIONNELLE

HSSCo 5%		(Réf. BC5)	   					
POINTE CARBURE		(Réf. BW6)						
HSS		(Réf. BMRP)						
RÉFÉRENCE	M9330		M9331		M9332		M9382	
QUANTITÉ	8		9		9		18	
QUALITÉ	 		  		  		  	
CONTENU	Ø 4 - 5 - 6 - 8 mm x 2		Ø 4 - 6 - 8 mm x 3		Ø 5 - 6 - 8 mm x 3		Ø 3 - 4 - 5 - 6 - 8 - 10 mm x 3	
PRIX €	36,14		36,46		37,68		72,63*	

*Jusqu'à fin de stock

SÉRIE EXTRA-PROFESSIONNELLE

HSSCo 5%		(Réf. BC5)	   					
POINTE CARBURE		(Réf. BW15)						
HSS		(Réf. BMRP)						
RÉFÉRENCE	P9330		P9331		P9332		P9382	
QUANTITÉ	8		9		9		18	
QUALITÉ	 		  		  		  	
CONTENU	Ø 4 - 5 - 6 - 8 mm x 2		Ø 4 - 6 - 8 mm x 3		Ø 5 - 6 - 8 mm x 3		Ø 3 - 4 - 5 - 6 - 8 - 10 mm x 3	
PRIX €	59,52*		56,36*		55,67*		114,71*	

*Jusqu'à fin de stock

ARMOIRES PRÉSENTOIRS POUR FORETS DIN 338

Forets pour métaux

Gris

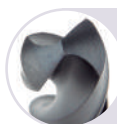
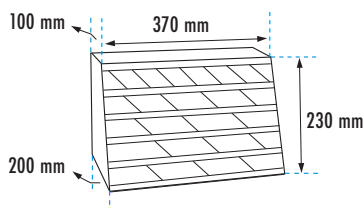

Réf. BC2

DIN 338

HSS



118°



30° "N"



OX



70 Kg/mm²



HSS

CONTENU 400 FORETS

Forets BC2

1,00	1,50	2,00	2,50	3,00	3,50	4,00	4,50	5,00	5,50	6,00	6,50	7,00
10	10	20	20	50	30	40	20	40	10	30	10	10
7,50	8,00	8,50	9,00	9,50	10,00	10,50	11,00	11,50	12,00	12,50	13,00	
10	20	10	10	10	10	5	5	5	5	5	5	

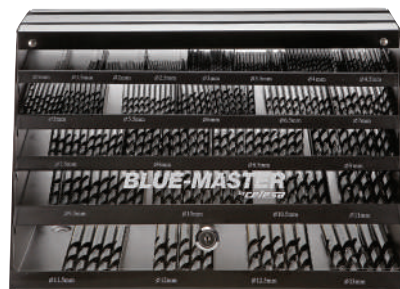

EXPBROCASBC2

1.320,00 €



Réf. BC02

DIN 338

HSS-Plus



118°



30° "N"



OX DORÉ



70 Kg/mm²



HSS-Plus



CONTENU 316 FORETS

Forets BC02

1,00	1,50	2,00	2,50	3,00	3,50	4,00	4,50	5,00	5,50	6,00	6,50	7,00
10	10	20	10	20	10	30	10	30	10	30	10	10
7,50	8,00	8,50	9,00	9,50	10,00	10,50	11,00	11,50	12,00	12,50	13,00	
10	20	10	10	10	10	6	6	6	6	6	6	

EXPBROCASBC02

1.371,34 €

ARMOIRES PRÉSENTOIRS POUR FORETS DIN 338



EXPBROCASBC5
1.783,35 €



Réf. BC5

DIN 338

HSSCo 5%



DORÉ

120 Kg/mm²



CONTENU 220 FORETS

Forets BC5

1,00 10	1,50 10	2,00 10	2,50 10	3,00 10	3,50 10	4,00 10	4,50 10	5,00 10	5,50 10	6,00 10	6,50 10	7,00 10
7,50 10	8,00 10	8,50 10	9,00 10	9,50 10	10,00 10	10,50 5	11,00 5	11,50 5	12,00 5	12,50 5	13,00 5	



Réf. BC18

DIN 338

HSS



TiN



TiN



CONTENU 200 FORETS

Forets BC18

1,00 10	1,50 10	2,00 10	2,50 10	3,00 10	3,50 10	4,00 10	4,50 10	5,00 10	5,50 10	6,00 10	6,50 10	7,00 10
7,50 10	8,00 10	8,50 5	9,00 5	9,50 5	10,00 5	10,50 5	11,00 5	11,50 5	12,00 5	12,50 5	13,00 5	



EXPBROCASBC18
1.239,80 €

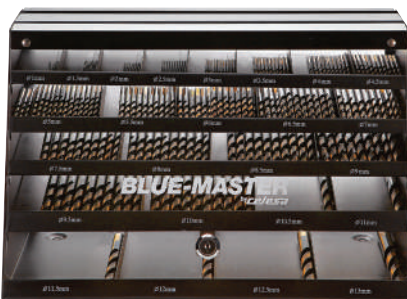

EXPBROCASBC95
1.141,82 €



Réf. BC95

DIN 338

HSSCo 5%



OX DORÉ

INOX



CONTENU 176 FORETS

Forets BC95

1,00 10	1,50 10	2,00 10	2,50 10	3,00 10	3,50 10	4,00 10	4,50 10	5,00 10	5,50 10	6,00 10	6,50 10	7,00 10
7,50 10	8,00 10	8,50 5	9,00 5	9,50 5	10,00 5	10,50 1	11,00 1	11,50 1	12,00 1	12,50 1	13,00 1	

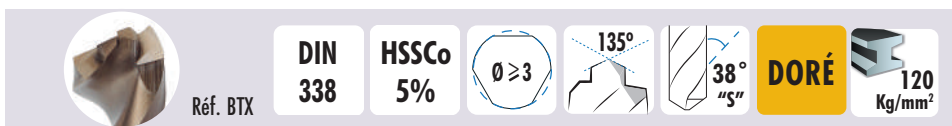
ARMOIRES PRÉSENTOIRS POUR FORETS DIN 338

CONTENU 176 FORETS

Forets BC5 (Ø1-2,5mm) Forets BTX (Ø3-13mm)

<u>1,00</u> 10	<u>1,50</u> 10	<u>2,00</u> 10	<u>2,50</u> 10	<u>3,00</u> 10	<u>3,50</u> 10	<u>4,00</u> 10	<u>4,50</u> 10	<u>5,00</u> 10	<u>5,50</u> 10	<u>6,00</u> 10	<u>6,50</u> 10	<u>7,00</u> 10
<u>7,50</u> 10	<u>8,00</u> 10	<u>8,50</u> 5	<u>9,00</u> 5	<u>9,50</u> 5	<u>10,00</u> 5	<u>10,50</u> 1	<u>11,00</u> 1	<u>11,50</u> 1	<u>12,00</u> 1	<u>12,50</u> 1	<u>13,00</u> 1	



EXPBROCASBTX

104,00 €

EXPBROCASBTX

947,83 €

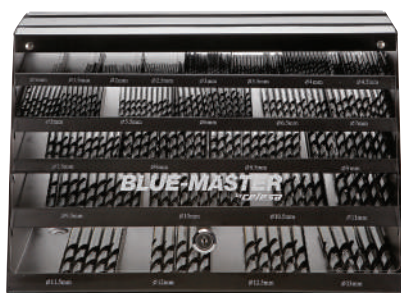

EXPBROCASTK02

1.724,78 €



CONTENU 176 FORETS

Forets TK02

<u>1,00</u> 10	<u>1,50</u> 10	<u>2,00</u> 10	<u>2,50</u> 10	<u>3,00</u> 10	<u>3,50</u> 10	<u>4,00</u> 10	<u>4,50</u> 10	<u>5,00</u> 10	<u>5,50</u> 10	<u>6,00</u> 10	<u>6,50</u> 10	<u>7,00</u> 10
<u>7,50</u> 10	<u>8,00</u> 10	<u>8,50</u> 5	<u>9,00</u> 5	<u>9,50</u> 5	<u>10,00</u> 5	<u>10,50</u> 1	<u>11,00</u> 1	<u>11,50</u> 1	<u>12,00</u> 1	<u>12,50</u> 1	<u>13,00</u> 1	

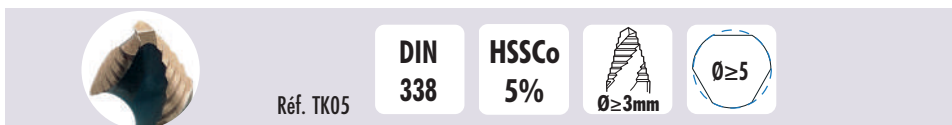

CONTENU 176 FORETS

Forets TK05

<u>1,00</u> 10	<u>1,50</u> 10	<u>2,00</u> 10	<u>2,50</u> 10	<u>3,00</u> 10	<u>3,50</u> 10	<u>4,00</u> 10	<u>4,50</u> 10	<u>5,00</u> 10	<u>5,50</u> 10	<u>6,00</u> 10	<u>6,50</u> 10	<u>7,00</u> 10
<u>7,50</u> 10	<u>8,00</u> 10	<u>8,50</u> 5	<u>9,00</u> 5	<u>9,50</u> 5	<u>10,00</u> 5	<u>10,50</u> 1	<u>11,00</u> 1	<u>11,50</u> 1	<u>12,00</u> 1	<u>12,50</u> 1	<u>13,00</u> 1	



EXPBROCASTK05

2.181,38 €

FORETS EN VALISE MÉTALLIQUE



DIN 338

125 FORETS Ø 1-10 mm x 0,50

Ø	1	1,50	2	2,50	3	3,50	4	4,50
Unités	10	5	10	5	10	5	10	5
	5	5,50	6	6,50	7	7,50	8	8,50
	10	5	10	5	5	5	5	5
	9	9,50	10	= 125 FORETS				
	5	5	5					



RÉFÉRENCE	BC2880	BC02880	BC5880	BC18880	M0880V
QUANTITÉ	125	125	125	125	250
QUALITÉ	HSS	Plus	HSSCo 5%	HSS TiN	
CONTENU	Ø 1-10 x 0,50 VOIR DÉTAIL	Ø 1-10 x 0,50 VOIR DÉTAIL	Ø 1-10 x 0,50 VOIR DÉTAIL	Ø 1-10 x 0,50 VOIR DÉTAIL	COFFRET VIDE
PRIX €	410,78	459,88	679,99	563,93	159,26



DIN 338

155 FORETS Ø 1-13 mm x 0,50

Ø	1	1,50	2	2,50	3	3,50	4	4,50	5
Unités	10	5	10	5	10	5	10	5	10
	5,50	6	6,50	7	7,50	8	8,50	9	9,50
	5	10	5	5	5	5	5	5	5
	10	10,50	11	11,50	12	12,50	13	=155 FORETS	
	5	5	5	5	5	5	5		



RÉFÉRENCE	BC2881	BC02881	BC5881	BC18881	M0881V
QUANTITÉ	155	155	155	155	290
QUALITÉ	HSS	Plus	HSSCo 5%	HSS TiN	
CONTENU	Ø 1-10 x 0,50 VOIR DÉTAIL	Ø 1-10 x 0,50 VOIR DÉTAIL	Ø 1-10 x 0,50 VOIR DÉTAIL	Ø 1-10 x 0,50 VOIR DÉTAIL	COFFRET VIDE
PRIX €	825,10	916,49	1.464,20	1.077,64	368,78

VALISE MÉTALLIQUE DE FORETS CONIQUES

DIN 345

HSS



(Forets Réf. BC11)

RÉFÉRENCE	MBC11-1	MBC11-2
QUANTITÉ	10	10
QUALITÉ	HSS	HSS
CONTENU	Ø 14 - 15 - 16 - 17 - 18 - 19 - 20 - 21 - 22 - 23	Ø 14 - 16 - 18 - 20 - 22 - 24 - 25 - 26 - 28 - 30
PRIX €	690,20	960,75

CONDITIONS DE COUPE DES FORETS AVEC VITESSE ET AVANCE

			DIAMÈTRE Ø (mm)											
			2	3	5	7	10	12	15	18	20	22	25	30
ACIER 70 kg/mm ² BC2	V/C 25 m/min	RPM	3979	2653	1592	1137	796	663	531	442	398	362	318	265
		mm / tour	0,04	0,06	0,08	0,15	0,20	0,26	0,30	0,33	0,34	0,35	0,35	0,39
		S (mm / min)	159	159	127	171	159	172	159	146	135	127	111	103
ACIER TREMPÉ 120 kg/mm ² BC5	V/C 13 m/min	RPM	2069	1379	828	591	414	345	276	230	207	188	166	138
		mm / tour	0,03	0,045	0,06	0,10	0,15	0,18	0,20	0,22	0,23	0,25	0,25	0,28
		S (mm / min)	62	62	50	59	62	60	55	51	48	47	41	39
INOX BC50	V/C 11 m/min	RPM	1751	1167	700	500	350	292	233	195	175	159	140	117
		mm / tour	0,02	0,05	0,08	0,14	0,19	0,23	0,25	0,27	0,28	0,30	0,31	0,33
		S (mm / min)	35	58	56	70	67	67	58	53	49	48	43	39
ALUMINIUM BC16	V/C 50 m/min	RPM	7958	5305	3183	2274	1592	1326	1061	884	796	723	637	531
		mm / tour	0,03	0,06	0,08	0,16	0,20	0,23	0,25	0,28	0,29	0,30	0,30	0,36
		S (mm / min)	239	318	255	364	318	305	265	248	231	217	191	191
TITANE BC7	V/C 18 m/min	RPM	5570	3714	2228	1592	1114	928	743	619	557	506	446	371
		mm / tour	0,02	0,03	0,03	0,05	0,08	0,08	0,12	0,15				
		S (mm / min)	111	111	67	80	84	74	89	93				
FONTE BC7	V/C 25 m/min	RPM	3979	2653	1592	1137	796	663	531	442	398	362	318	265
		mm / tour	0,05	0,08	0,10	0,20	0,27	0,31	0,37	0,41	0,42	0,42	0,42	0,45
		S (mm / min)	199	199	159	227	215	206	196	181	167	152	134	119
LAITON BC66	V/C 50 m/min	RPM	7958	5305	3183	2274	1592	1326	1061	884	796	723	637	531
		mm / tour	0,04	0,07	0,08	0,17	0,21	0,25	0,28	0,28	0,30	0,30	0,33	0,40
		S (mm / min)	318	345	239	387	334	332	297	248	239	217	210	212
PLASTIQUE, FIBRE DE CARBONE BC7	V/C 12 m/min	RPM	1911	1274	764	546	382	318	255	212	191	174	153	127
		mm / tour	0,02	0,03	0,03	0,05	0,08	0,08	0,12	0,15				
		S (mm / min)	38	38	23	27	29	25	31	32				
ALLIAGE DE NI BC42	V/C 30 m/min	RPM	4775	3183	1910	1364	955	796	637	531	477	434	382	318
		mm / tour	0,015	0,02	0,02	0,03	0,04	0,06	0,07	0,08	0,11	0,12	0,15	
		S (mm / min)	72	64	42	34	38	48	45	42	53	52	57	
CIRCUIT IMPRIMÉ BC79	25	RPM	3979	-	-	-	-	-	-	-	-	-	-	

OBSERVATIONS:

- Si nous connaissons le diamètre du foret et la matière à usiner, la vitesse et l'avance sont indiquées.

Exemple:

Matériel: Aluminium

RPM=2274

Ø de foret: 7 mm. → S=364 mm/min

- Après plusieurs trous, il est recommandé de régler la vitesse et l'avance à nouveau.

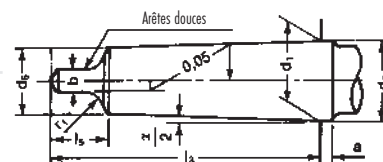
INFORMATION TECHNIQUE SUR DIMENSIONS DE CÔNE MORSE DIN 228D

CÔNE MORSE	Amincissement	Ø 2	a	b h13	d ₁	d ₂ Ø max =	d ₆ Ø min =	d ₇ Dimen. max.	l ₃ -1	l ₄ Dimen. min.	l ₅ Dimen. min.	r ₁	r ₂
0	1:19,212=0,05205	1°29 27"	3,0	3,9	9,045	9,2	6,1	6,0	56,5	59,5	10,5	4	1,0
1	1:20,047=0,04988	1°25 43"	3,5	5,2	12,065	12,2	9,0	8,7	62,0	65,5	13,5	5	1,2
2	1:20,020=0,04995	1°25 50"	5,0	6,3	17,780	18,0	14,0	13,5	75,0	80,0	16,0	6	1,6
3	1:19,922=0,05020	1°26 16"	5,0	7,0	23,825	24,1	19,1	18,5	94,0	99,0	20,0	7	2,0
4	1:19,254=0,05194	1°29 15"	6,5	11,9	31,267	31,6	25,2	24,5	117,5	124,0	24,0	8	2,5
5	1:19,002=0,05263	1°30 26"	6,5	15,9	44,399	44,7	36,5	35,7	149,5	156,0	29,0	10	3,0
6	1:19,180=0,05214	1°29 36"	8,0	19,0	63,348	63,8	52,4	51,0	210,0	218,0	40,0	10	4,0