

COUNTERSINKS

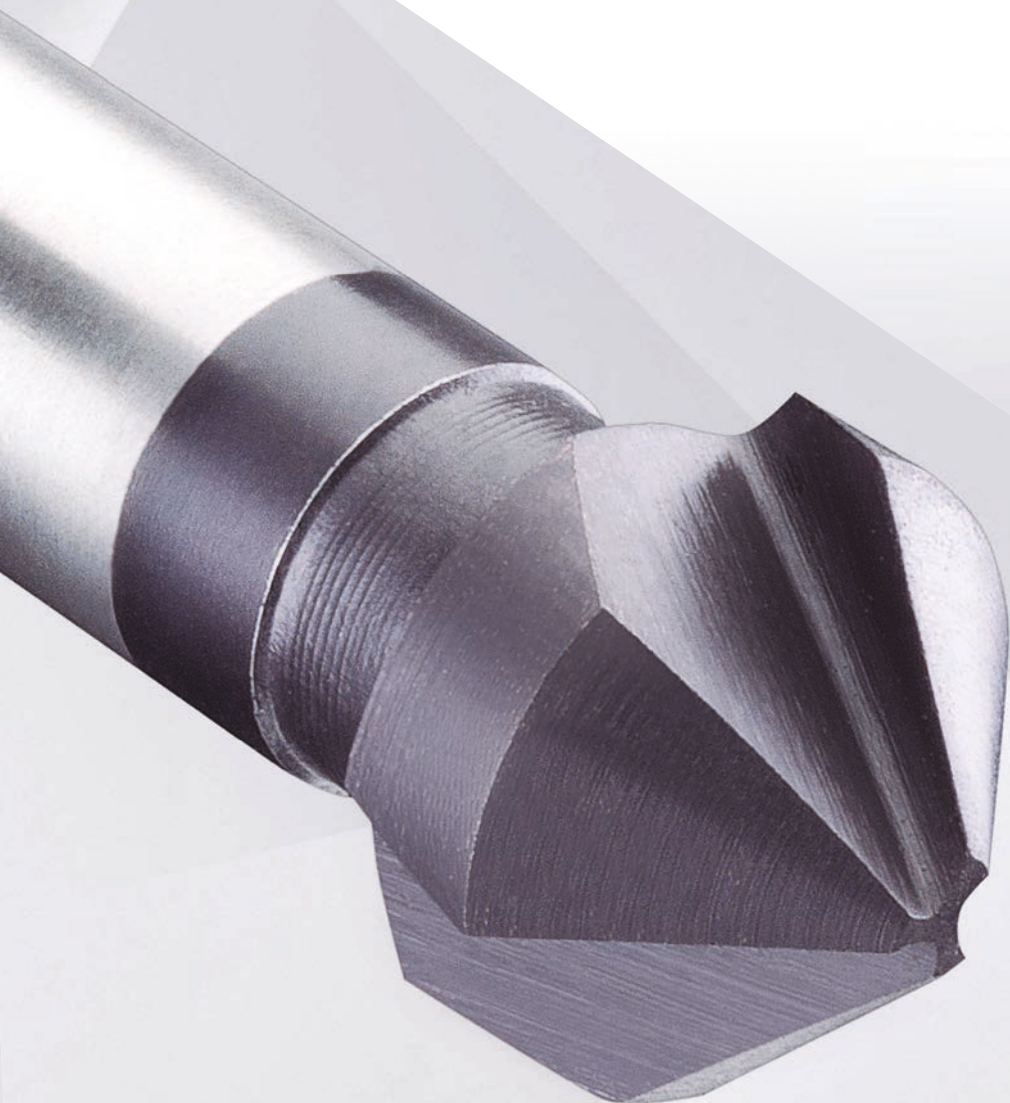

BLUE-MASTER[®]
by *celesa*

CUTTING TECHNOLOGIES

HSS & HSSCo TUBE AND SHEET DRILLS
HSS

Ref. AV30

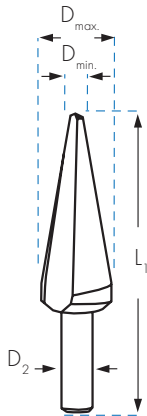
118°

BM0 BM1 BM5 BM3 BM4 BM6

AV30

	D min. mm	D max. mm	D ₂ mm	L ₁ mm	HSS	TiN
					€	€
AV30BM0B	3,0	14,0	6,0	58	19,54	39,06
AV30BM8B	3,0	22,5	8,0	85	54,03	97,91
AV30BM5B	3,0	31,0	10,0	102	86,40	129,48
AV30BM9B	5,0	25,4	10,0	87	61,44	117,37
AV30BM1B	6,0	20,0	8,0	63	27,57	57,00
AV30BM2B	16,0	30,0	10,0	79	53,33	94,32
AV30BM3B	26,0	40,0	13,0	86	110,34	172,79
AV30BM4	36,0	50,0	13,0	89	162,52	250,70
AV30BM6	40,0	61,0	13,0	98	269,24	419,29

* The references ended by a B are supplied in blister packaging

HSSCo

Ref. AVC30

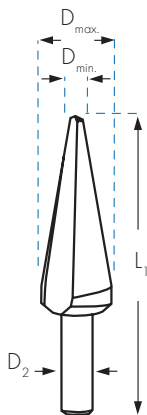
118°

BM0 BM1 BM2 BM3

AVC30

	D min. mm	D max. mm	D ₂ mm	L ₁ mm	HSSCo	TiN
					€	€
AVC30BM0B	3,0	14,0	6,0	58	36,17	47,25
AVC30BM1B	6,0	20,0	8,0	63	47,96	72,84
AVC30BM2B	16,0	30,0	10,0	79	79,14	105,51
AVC30BM3B	26,0	40,0	13,0	86	205,91	222,21

HSS TUBE & SHEET DRILLS

HSS

Ref. AG

Countersink Drill for tube and metal and light alloy sheets, also for plastic materials. Suitable up to 5mm depth.

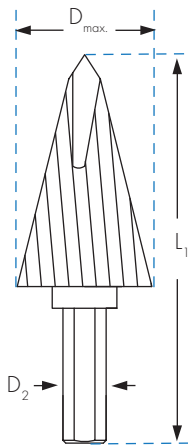

TUBE AND SHEET DRILLS

	D _{max.} mm	D ₂ mm	L ₁ mm	N° Z	AG	
					HSS	€
AG2500	25,0	8,0	72	20	HSS	27,59
AG3200	32,0	10,0	81	30	HSS	41,43
AG4500	45,0	10,0	94	36	HSS	68,43

HSS

Ref. AV31



SPIRAL FLUTED WITH STOPPER

	D _{min.} mm	D _{max.} mm	D ₂ mm	L ₁ mm	AV31	
					HSS	TiN
					€	€
AV31BM0B	3,0	7,8	6,0	48	31,32	47,40
AV31BM1B	3,0	10,2	6,0	52	41,13	64,48
AV31BM2B	3,0	11,8	6,0	56	45,77	80,88

HSS STRAIGHT FLUTED STEP DRILLS
HSS

Ref. AV40

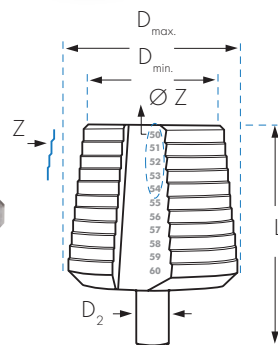
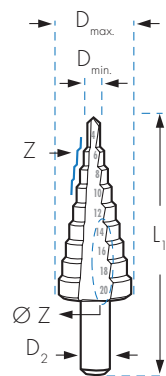
BM1
BM2
BM3
BM4
BM5
AV40

	D min. mm	D max. mm	D ₂ mm	L ₁ mm	Z	Ø Z mm min - max	HSS	TiN
							€	€
AV40BM1B	4,0	12,0	6,0	65	5	4-6-8-10-12	40,72	62,38
AV40BM2B	4,0	12,0	6,0	65	9	4-5-6-7-8-9-10-11-12	40,55	62,74
AV40BM3B	4,0	20,0	8,0	69	9	4-6-8-10-12-14-16-18-20	51,99	80,08
AV40BM4B	4,0	30,0	10,0	96	14	4-6-8-10-12-14-16-18-20-22-24-26-28-30	85,28	130,00
AV40BM14	4,0	39,0	10,0	107	13	4-6-9-12-15-18-21-24-27-30-33-36-39	211,59	326,75
AV40BM16B	5,0	28,0	10,0	69	7	5-8-8-11,8-15,3-19-24,5-28	98,15	154,46
AV40BM35B	5,0	35,0	13,0	80	13	5-7-10-12-15-17-20-22-25-27-30-32-35	127,06	184,74
AV40BM11B	6,0	25,0	10,0	65	7	6-9-12-16-20-22,50-25	80,15	114,77
AV40BM10B	6,0	26,7	10,0	75	8	6-9-11,40-14-17,25-19-21,25-26,75	156,05	245,56
AV40BM17B	6,0	30,5	10,0	80	9	6-9-12,5-15,2-18,6-20,4-22,5-28,3-30,5	165,68	260,71
AV40BM12B	6,0	32,0	10,0	75	9	6-9-12-16-20-22,5-25-28,5-32	113,12	154,64
AV40BM18B	6,0	37,0	10,0	100	12	6-9-12,5-15,2-18,6-20,4-22,5-26-28,3-30,5-34-37	184,13	285,40
AV40BM5B	6,0	38,0	10,0	96	12	6-9-13-16-19-21-23-26-29-32-35-38	198,66	284,04
AV40BM13	6,0	40,0	13,0	105	16	6-11-17-23-29-30-31-32-33-34-35-36-37-38-39-40	273,95	336,61
AV40BM15B	6,5	32,5	10,0	79	9	6,50-8,50-10,50-12,50-16,50-20,50-25,50-29-32,50	130,97	183,55
AV40BM20	6,5	40,5	10,0	96	11	6,50-8,50-10,50-12,50-16,50-20,50-25,50-29-32,50-36,50-40,50	205,33	323,12
AV40BM21B	7,0	20,0	10,0	80	12	7-10-11-12-13-14-15-16-17-18-19-20	82,16	129,28
AV40BM22B	10,0	30,0	13,0	83	12	10-20-21-22-23-24-25-26-27-28-29-30	128,60	201,76
AV40BM25B	12,0	20,0	8,0	66	9	12-13-14-15-16-17-18-19-20	76,17	101,95
AV40BM26B	20,0	30,0	10,0	78	11	20-21-22-23-24-25-26-27-28-29-30	111,12	156,53
AV40BM27	30,0	40,0	10,0	78	11	30-31-32-33-34-35-36-37-38-39-40	166,43	214,27
AV40BM28	40,0	50,0	13,0	85	11	40-41-42-43-44-45-46-47-48-49-50	237,92	331,60
AV40BM29	50,0	60,0	13,0	85	11	50-51-52-53-54-55-56-57-58-59-60	299,78	372,38

FOR TUBES IN GAS THREAD

AV40BM6B	6,0	32,0	10,0	75	8	6-9-11,20(1/8)-14,50(1/4)-18,20(3/8)-22,30(1/2)-27,90(3/4)-32	117,36	160,88
----------	-----	------	------	----	---	---	--------	--------

FOR BLIND RIVETS M3 - M4 - M5 - M6 - M7

AV40BM7B	4,8	10,6	6,0	54	5	4,80-6,40-7,20-9,60-10,65	38,24	54,56
----------	-----	------	-----	----	---	---------------------------	-------	-------

FOR ELECTRICAL CONDUCTIONS (OLD & NEW NORMS)

AV40PG21B	PG7	PG21	13,0	70	11	6,5-8,5-10,5-12,5(PG7)-15,2(PG9)-18,6(PG11) 20,4(PG13,5)-22,5(PG16)-25,5-18,3(PG21)-30,5	129,23	182,70
AV40PG29B	PG7	PG29	13,0	81	14	6,5-9-11-12,5(PG7)-15,2(PG9)-18,6(PG11)-20,4(PG13,5) 22,5(PG16)-26-28,3(PG21)-30,5-33-35-37(PG29)	166,95	234,20
AV40BM8B	8,5	32,5	10,0	70	12	8,5-10,5-12,5-14,5-16,5-18,5-20,5-23,5-25,5 28-30,5-32,5	97,97	150,64
AV40BM9B	8,5	40,5	12,0	84	16	8,5-10,5-12,5-14,5-16,5-18,5-20,5-23,5-25,5 28-30,5-32,5-34,5-36,5-38,5-40,5	143,69	224,93

HSSCo STRAIGHT FLUTED STEP DRILLS

HSSCo **INOX** Ref. AVC40

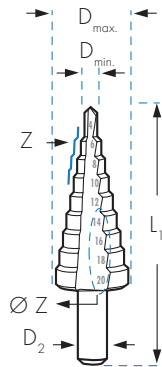

BM1 BM2 BM3 BM4 BM18

								AVC40	
	D min. mm	D max. mm	D2 mm	L1 mm	Z	Ø Z mm min - max	HSSCo €	TiN €	
AVC40BM1B	4,0	12,0	6,0	65	5	4-6-8-10-12	62,60	90,33	
AVC40BM2B	4,0	12,0	6,0	65	9	4-5-6-7-8-9-10-11-12	66,10	109,10	
AVC40BM3B	4,0	20,0	8,0	69	9	4-6-8-10-12-14-16-18-20	99,91	123,61	
AVC40BM4B	4,0	30,0	10,0	96	14	4-6-8-10-12-14-16-18-20-22-24-26-28-30	143,70	193,77	
AVC40BM18B	6,0	37,0	10,0	100	12	6-9-12,5-15,2-18,6-20,4-22,5-26-28,3-30,5-34-37	257,43	325,55	

HSS SPIRAL FLUTED STEP DRILLS

HSS Ref. AV42

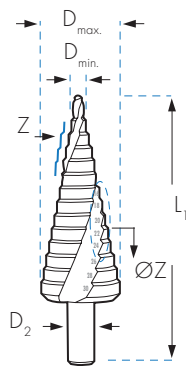

BM2 BM3 BM4

								AV42	
	D min. mm	D max. mm	D2 mm	L1 mm	Z	Ø Z mm min - max	HSS €	TiN €	
AV42BM1B	4,0	12,0	6,0	65	5	4-6-8-10-12	53,78	72,73	
AV42BM2B	4,0	12,0	6,0	68	9	4-5-6-7-8-9-10-11-12	55,63	75,74	
AV42BM3B	4,0	20,0	8,0	69	9	4-6-8-10-12-14-16-18-20	74,20	105,89	
AV42BM4B	4,0	30,0	10,0	96	14	4-6-8-10-12-14-16-18-20-22-24-26-28-30	118,03	168,58	
AV42BM5B	6,0	38,0	10,0	96	12	6-9-13-16-19-21-23-26-29-32-35-38	230,22	300,73	
AV42BM11B	6,0	25,0	10,0	65	7	6-9-12-16-20-22,50-25	95,53	124,20	
AV42BM12B	6,0	32,0	10,0	75	9	6-9-12-16-20-22,5-25-28,5-32	124,60	156,30	
AV42BM13	6,0	40,0	13,0	105	16	6-11-17-23-29-30-31-32-33-34-35-36-37-38-39-40	275,03	355,09	
AV42BM8B	8,5	32,5	10,0	70	12	8,5-10,5-12,5-14,5-16,5-18,5-20,5-23,5 25,5-28-30,5-32,5	125,76	162,53	
AV42BM9B	8,5	40,5	12,0	84	16	8,5-10,5-12,5-14,5-16,5-18,5-20,5-23,5 25,5-28-30,5-32,5-34,5-36,5-38,5-40,5	197,76	240,53	

HSS SPIRAL FLUTED STEP DRILLS
HSS
1/4" HEXAGONAL SHANK

	D min. mm	D max. mm		L ₁ mm	Z	Ø Z mm min - max	AV41	
							HSS €	TiN €
AV41BM2B	4,0	12,0	1/4"	72	9	4-5-6-7-8-9-10-11-12	89,48	110,95
AV41BM3B	4,0	20,0	1/4"	81	9	4-6-8-10-12-14-16-18-20	118,29	146,71
AV41BM4B	4,0	30,0	1/4"	105	14	4-6-8-10-12-14-16-18-20-22-24-26-28-30	140,21	168,90



Ref. AV41BM2B

SHORT SERIES max. 2mm thick

	D min. mm	D max. mm	D ₂ mm	L ₁ mm	Z	Ø Z mm min - max	AV41C	
							HSS €	TiN €
AV41CBM2B	4,0	12,0	6,0	48	9	4-5-6-7-8-9-10-11-12	63,67	85,46
AV41CBM3B	4,0	20,0	8,0	58	9	4-6-8-10-12-14-16-18-20	79,05	110,45
AV41CBM4B	4,0	30,0	10,0	72	14	4-6-8-10-12-14-16-18-20-22-24-26-28-30	128,87	198,42



Ref. AV41CBM3B

STRAIGHT FLUTED FOR ELECTRICIANS

	DIN	D min. mm	D max. mm	D ₂ mm	L ₁ mm	Z	Ø Z mm min - max	AV45	
								HSS €	TiN €
AV45BM0B	60423	5,3	30,5	10,0	79	9	5,3-7-9-10,5-14,5-18,5-23,5-27-30,5	175,67	226,53
AV45BM2B	60423	5,3	38,5	10,0	96	11	5,3-7-9-10,5-14,5-18,5-23,5-27-30,5-34,5-38,5	211,25	266,90



Ref. AV45BM2B

3 STRAIGHT FLUTED

	D min. mm	D max. mm	D ₂ mm	L ₁ mm	Z	Ø Z mm min - max	AV43	
							HSS €	TiN €
AV43BM1B	4,0	12,0	6,0	65	9	4-5-6-7-8-9-10-11-12	76,74	100,41
AV43BM2B	4,0	20,0	8,0	75	9	4-6-8-10-12-14-16-18-20	105,21	163,02
AV43BM3B	4,0	30,0	10,0	100	14	4-6-8-10-12-14-16-18-20-22-24-26-28-30	154,68	252,99

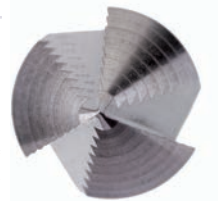

Ref. AV43BM3B

STEP DRILL WITH INTERCHANGEABLE PILOT DRILL

	D min. mm	D max. mm	D ₂ mm	L ₁ mm	Z	Ø Z mm min - max	AV4	
							HSS €	
AV4BM3040	30,0	40,0	13,0	76	11	30-31-32-33-34-35-36-37-38-39-40	161,00	
AV4BM4050	40,0	50,0	13,0	76	11	40-41-42-43-44-45-46-47-48-49-50	232,54	
AV4BM5060	50,0	60,0	13,0	76	11	50-51-52-53-54-55-56-57-58-59-60	295,19	



Ref. AV4BM3040

PILOT DRILLS

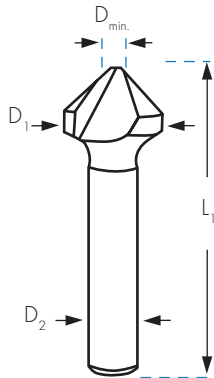

		BAV4BM
		€
BAV4BM	DESCRIPTION	10X35mm
		10,42

3 FLUTED COUNTERSINKS

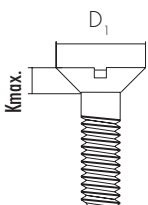

				AV6	AV16	AV37	AV7	AV38	AV99	AV6MD	AV15	
MATERIAL				HSS	HSS	HSS	HSSCo	HSSCo	HSSCo	CARBIDE		HSS
COATING					TiN	TiAlN		TiAlSiN	TiAlN			
APPLICATION				GENERAL PURPOSE	GENERAL PURPOSE	GENERAL PURPOSE	GENERAL PURPOSE INOX	INOX Plus	INOX SpheroPlus Al	HARDOX 450		
D1 mm	D _{min.} mm	D2 mm	L1 mm	€	€	€	€	€	€	€	L1 mm	€
4,30	1,3	4,0	40	17,53	32,38	38,12	19,50	46,57		65,77		
5,00	1,5	4,0	40	17,53	32,38	38,12	19,50	46,57				
5,30	1,5	4,0	40	17,53	32,38	38,12	19,50	46,57		63,32		
5,80	1,5	5,0	45	13,31	28,45	35,78	15,87	40,77				
6,00	1,5	5,0	45	12,69	27,83	35,78	15,25	40,27		65,43		
6,30	1,5	5,0	45	12,46	27,83	35,78	14,97	40,05	40,49	70,74		
7,00	1,8	6,0	50	17,53	37,15	47,72	19,50	54,16				
7,30	1,8	6,0	50	17,53	37,15	47,72	19,50	54,16				
8,00	2,0	6,0	50	17,53	37,15	47,72	19,71	54,31		75,36		
8,30	2,0	6,0	50	17,27	37,15	47,72	19,35	54,01	54,61	80,37		
9,40	2,2	6,0	50	20,44	41,92	53,47	22,81	61,48				
10,00	2,5	6,0	50	20,44	41,92	53,47	22,81	61,48		83,07		
10,40	2,5	6,0	50	20,07	41,92	53,47	23,29	61,31	61,99	87,66	112	62,39
11,50	2,8	8,0	56	20,54	44,41	57,49	24,89	66,64				
12,00	2,8	8,0	56	20,54	44,41	57,49	24,89	66,65				
12,40	2,8	8,0	56	20,54	44,41	57,49	24,88	66,65	67,39	91,41	112	76,81
13,40	2,9	8,0	56	22,21	45,88	59,38	27,15	69,80				
15,00	3,2	10,0	60	28,20	61,65	81,30	34,57	93,39		95,20		
16,50	3,2	10,0	60	27,73	63,31	81,30	34,10	92,97	94,01	100,11	120	92,56
19,00	3,5	10,0	63	41,53	77,24	98,66	51,13	113,54				
20,50	3,5	10,0	63	40,82	78,89	101,63	50,20	114,99	116,26	138,81	124	124,06
23,00	3,8	10,0	67	51,05	89,87	113,73	62,31	133,53				
25,00	3,8	10,0	67	51,51	91,14	114,91	63,42	135,31	136,81	226,50	128	149,62
28,00	4,0	12,0	71	71,93	115,85	148,70	90,57	181,84				
30,00	4,2	12,0	71	76,44	120,20	193,78	95,79	219,29				
31,00	4,2	12,0	71	79,57	124,59	208,09	95,79	214,54		255,58	133	175,27
40,00	6,5	13,0	80	118,32	190,15	244,66	149,54	267,75		443,75*		

* Shank 16 mm



90° TAPER HEAD SCREWS DIMENSIONS

	M2	M2.5	M3	M4	M5	M6	M8	M10	M12	M14	M16	M18	M20
Kmax.	1,2	1,5	1,7	2,3	2,8	3,3	4,4	5,5	6,5	7	7,5	8	8,5
D1	4	5	6	8	10	12	16	20	24	27	30	33	36

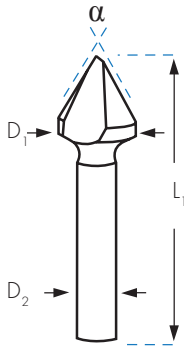
60°, 75°, 120° HSS COUNTERSINKS
3Z

				AV8		AV9		AV10	
MATERIAL				HSS		HSS		HSS	
DIN				DIN 334C		NORM CELESA		NORM CELESA	
POINT ANGLE				60°		75°		120°	
D ₁ mm	D _{min.} mm	D ₂ mm	L ₁ mm	€		€		€	
6,30	1,5	5,0	45	AV80630	20,06	AV90630	15,44	AV100630	16,44
8,00	2,0	6,0	50	AV80800	22,05				
8,30	2,0	6,0	50			AV90830	21,05	AV100830	22,65
10,00	2,5	6,0	50	AV81000	24,05				
10,40	2,5	6,0	50			AV91040	24,87	AV101040	26,47
12,40	2,8	8,0	56	AV81250	26,67	AV91240	27,48	AV101240	31,69
16,50	3,2	10,0	60	AV81600	34,11	AV91650	34,47	AV101650	40,10
20,50	3,5	10,0	63	AV82000	48,14	AV92050	50,74	AV102050	59,16
25,00	3,8	10,0	67	AV82500	67,18	AV92500	63,96	AV102500	74,61
40,00	6,5	13,0	67	AV84000	154,34	AV94000	139,16	AV104000	163,99

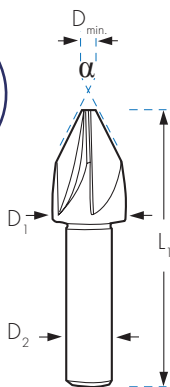
60°, 90° & 120° MULTICUTTING COUNTERSINKS
5Z

				AV12		AV11		AV13				
MATERIAL				HSS		HSS		HSS				
DIN				DIN 334A		DIN 335A		DIN 347A				
POINT ANGLE				60°		90°		120°				
D ₁ mm	D _{min.} mm	D ₂ mm	N° Z	L ₁ mm	€	L ₁ mm	€	L ₁ mm	€			
8,00	2,5	8,0	5	AV120800	48	17,53	AV110800	44	13,18	AV130800	44	17,47
12,50	2,8	8,0	5	AV121250	52	24,53	AV111250	48	19,31	AV131250	48	25,65
16,00	3,0	10,0	5	AV121600	60	41,16	AV111600	56	32,42	AV131600	56	43,03
20,00	3,5	10,0	5	AV122000	64	53,09	AV112000	60	41,76	AV132000	60	55,48
25,00	3,5	10,0	5	AV122500	69	74,31	AV112500	65	58,46	AV132500*	65	75,47

 * D₂: 12,00 mm

HSS & HSSCo DEBURRING COUNTERSINKS

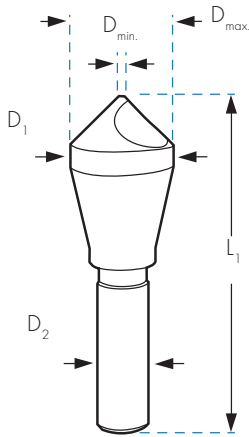

MATERIAL					AV1	AV1T	AV2	AV2T	AV1-60					
COATING					HSS	HSS	HSSCo	HSSCo	HSS					
POINT ANGLE														
D1 mm	Dmin. mm	Dmax mm	D2 mm	L1 mm	€	€	€	€	€					
6,35	2,0	5,0	6,35	45	AV100	14,31	AV100T	25,85	AV200	24,32	AV200T	40,91	AV100-60	25,63
10,00	2,0	5,0	6,00	45	AV101	17,64	AV101T	27,04	AV201	25,12	AV201T	40,91	AV101-60	32,02
14,00	6,0	13,0	8,00	50	AV102	22,04	AV102T	38,01	AV202	29,25	AV202T	51,01	AV102-60	38,87
20,00	8,0	18,0	10,00	65	AV103	39,46	AV103T	67,96	AV203	52,29	AV203T	86,34	AV103-60	44,34
27,00	11,0	25,0	12,00	85	AV104	70,52	AV104T	111,72	AV204	85,20	AV204T	136,02	AV104-60	77,25
30,00	12,0	28,0	15,00	95	AV105	119,02	AV105T	212,01	AV205	135,37	AV205T	233,72	AV105-60	126,60
35,00	14,0	33,0	15,00	100	AV106	182,80	AV106T	290,30	AV206	226,81	AV206T	393,05	AV106-60	200,63
40,00	16,0	38,0	15,00	110	AV107	252,39	AV107T	412,58	AV207	260,96	AV207T	421,11	AV107-60	271,91
45,00	18,0	42,0	15,00	120	AV108	334,41	AV108T	501,09	AV208	392,18	AV208T	558,65	AV108-60	351,42
50,00	20,0	48,0	15,00	130	AV109	403,49	AV109T	582,58	AV209	522,70	AV209T	701,38	AV109-60	428,19

MULTI FLUTES 90° CUTTERS

Ref. FC

TiAlN **SOLID CARBIDE**

D1 mm	D2 mm	L mm	L2 mm	D3 mm	Z	FC	€
0,5	0,1	39,0	3,0	3,0	3	FC0050	63,95
0,6	0,1	39,0	3,0	3,0	3	FC0060	63,95
0,7	0,1	39,0	3,0	3,0	3	FC0070	63,95
0,8	0,1	39,0	3,0	3,0	3	FC0080	63,95
0,9	0,1	39,0	3,0	3,0	3	FC0090	63,95
1,0	0,1	39,0	3,0	3,0	3	FC0100	61,74
1,5	0,1	39,0	4,5	3,0	3	FC0150	61,74
2,0	0,1	39,0	6,0	3,0	3	FC0200	61,74
2,5	0,1	39,0	7,5	3,0	3	FC0250	61,74
3,0	0,1	39,0	-	3,0	3	FC0300	61,74
4,0	0,8	54,0	-	4,0	4	FC0400	63,95
6,0	0,8	57,0	-	6,0*	4	FC0600	67,25
8,0	0,8	63,0	-	8,0*	5	FC0800	73,87
10,00	1,0	72,0	-	10,0*	6	FC1000	88,20
12,00	1,2	83,0	-	12,0*	6	FC1200	130,10
16,00	1,6	92,0	-	16,0*	6	FC1600	232,63
20,00	2,0	104,0	-	20,0*	6	FC2000	425,56

* Flat shank

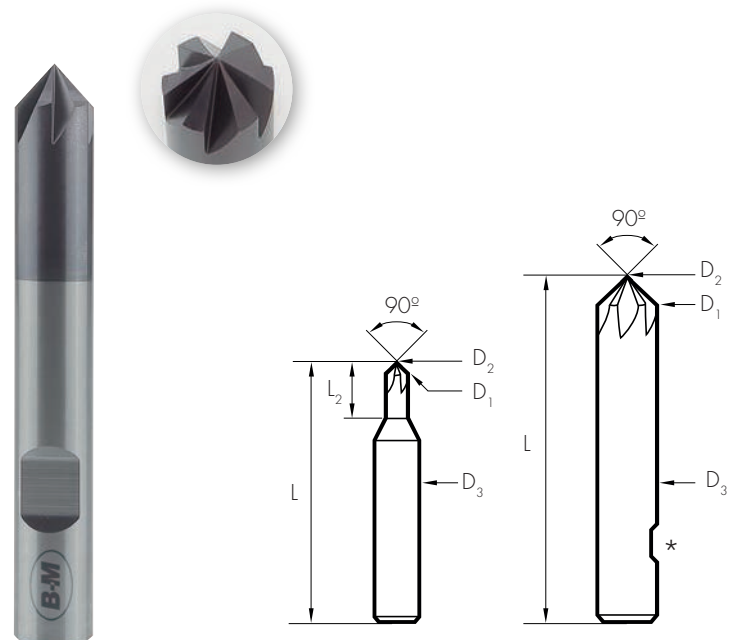

TAPER SHANK COUNTERSINKS
3Z

Ref. AV17

**DIN
335D**
HSS

90°

Ref. AV17MD

**DIN
335D**
**CARBIDE
TIPPED**

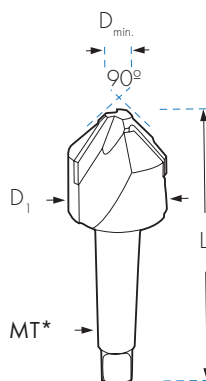
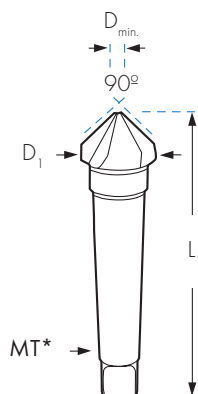
90°

AV17

AV17MD

D ₁ mm	D _{min.} mm	L ₁ mm	MT*	€
16,50	4,0	90	1	84,05
20,50	3,5	100	2	99,09
25,00	3,8	106	2	100,11
31,00	4,2	112	2	111,43
40,00	10,0	140	3	171,48
50,00	14,0	150	3	215,86
63,00	16,0	180	4	349,02
80,00	22,0	190	4	597,18
100,00	25,0	210	4	1.539,10

D ₁ mm	D _{min.} mm	L ₁ mm	MT*	€
63,00	16,0	190	4	1.460,79*
80,00	22,0	190	4	1.783,34*

*Till end of stock

TAPER SHANK COUNTERSINKS
**MULTI
CUTTING**

Ref. AV23

**DIN
334B**

60°

Ref. AV18

**DIN
335B**

90°

Ref. AV24

**DIN
347B**

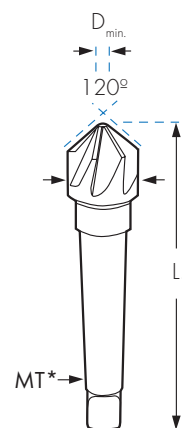
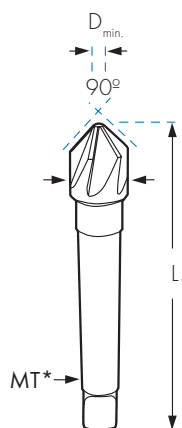
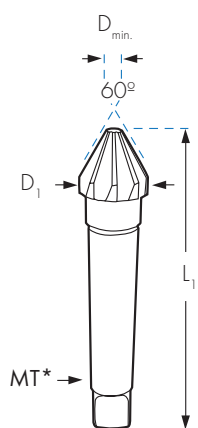
120°

AV23

AV18

AV24

D ₁ mm	D _{min.} mm	L ₁ mm	MT*	Z	HSS €
16,00	3,2	93	1	7	63,77
20,00	4,0	116	2	7	74,65
25,00	7,0	121	2	9	81,77
31,50	9,0	124	2	9	111,81
40,00	12,5	150	3	11	204,63
50,00	16,0	153	3	13	244,61
63,00	20,0	185	4	15	374,47
80,00	25,0	196	4	17	578,74
100,00	22,0	230	4	3	1.823,64

D ₁ mm	D _{min.} mm	L ₁ mm	MT*	Z	HSS €
16,00	3,2	93	1	7	65,04
20,00	4,0	116	2	7	76,06
25,00	7,0	121	2	9	83,41
31,50	9,0	124	2	9	114,08
40,00	12,5	150	3	11	208,77
50,00	16,0	153	3	13	249,44
63,00	20,0	185	4	15	358,12
80,00	25,0	196	4	17	590,36
100,00	22,0	190	4	20	1.591,39

D ₁ mm	D _{min.} mm	L ₁ mm	MT*	Z	HSS €
16,00	3,2	93	1	7	66,23
20,00	4,0	116	2	7	77,51
25,00	7,0	121	2	9	89,02
31,50	9,0	124	2	9	116,13
40,00	12,5	150	3	11	184,91
50,00	16,0	153	3	13	238,84
63,00	20,0	185	4	15	388,86
80,00	25,0	196	4	17	601,00
100,00	27,0	210	4	3	1.577,33

* Morse taper



SINGLE FLUTE COUNTERSINKS



HSS STRAIGHT SHANK
Ref. AV27
Ref. AV29

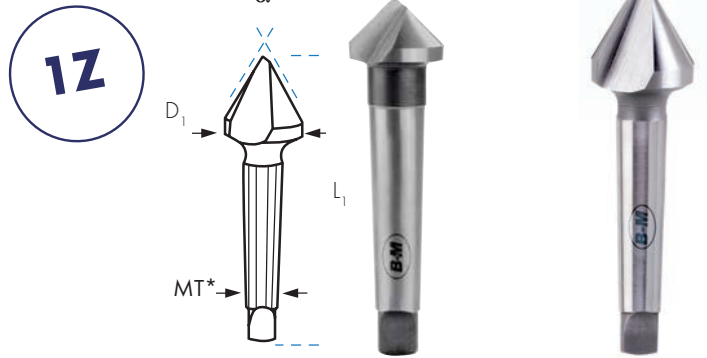
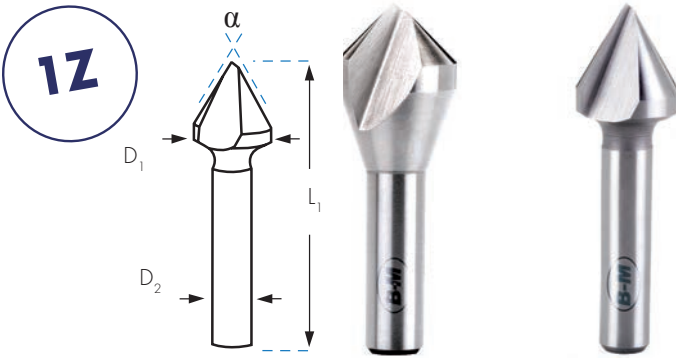

HSS MORSE TAPER SHANK
Ref. AV34
Ref. AV28

	D1 mm	D2 mm	L1 mm	 90° €	 60° €
AV270600	6,0	5,0	45	13,77	AV290600 25,40
AV270800	8,0	8,0	50	14,54	AV290800 26,60
AV271000	10,0	8,0	50	15,41	AV291000 27,85
AV271200	12,0	8,0	50	17,94	AV291200 31,29
AV271600	16,0	10,0	56	21,37	AV291600 38,10
AV272000	20,0	10,0	60	29,20	AV292000 48,97
AV272500	25,0	10,0	75	38,47	AV292500 77,11
AV273000	30,0	12,0	80	55,49	AV293000 100,70
AV274000	40,0	13,0	89	144,59	AV294000 175,04
AV275000	50,0	13,0	98	178,51	AV295000 261,50

	D1 mm	MT*	L1 mm	 90° €	 60° €
AV341600	16,0	1	92	66,20	AV281600 63,34
AV342000	20,0	2	107	82,97	AV282000 69,39
AV342500	25,0	2	110	106,84	AV282500 102,88
AV343000	30,0	2	114	121,41	AV283000 135,57
AV344000	40,0	3	145	195,35	AV284000 178,50
AV345000	50,0	3	152	285,25	AV285000 271,08

* Morse taper

3 FLUTED EXTERNAL CHAMFERING COUNTERSINKS

3Z **HSS**  Ref. AVX **HSS**  Ref. AVX-60

AVX					
Dmax. mm	Dmin. mm	D2 mm	L1 mm		€
12,00	4,0	8,0	55	AVX1	57,62
20,00	8,0	10,0	60	AVX2	107,34
28,00	10,0	13,0	70	AVX3	152,27
40,00	12,0	CM2	125	AVX4	231,07
50,00	15,0	CM3	130	AVX5	322,83

AVX-60					
Dmax. mm	Dmin. mm	D2 mm	L1 mm		€
8,00	3,0	8,0	55	AVX1-60	61,55
15,00	6,0	10,0	60	AVX2-60	118,12
28,00	10,0	13,0	75	AVX3-60	177,02

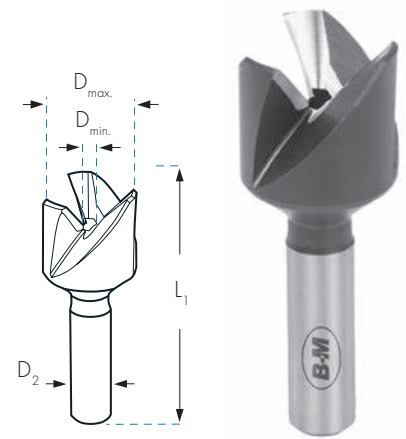

EXTERNAL COUNTERSINKS FOR RESTORING STARTING THREADS

Ref. AVEXT **HSS** 

Min.-Max.		L1 mm		€
M8-M18	1/4"	75	AVEXT	37,48



HSS COUNTERBORES FOR ALLEN SCREWS

STRAIGHT SHANK

DIN
373
HSS

NOTE: The guide is not included in the cutting length.
 * The core hole is used for counterboring threaded holes.

Ref. AV2

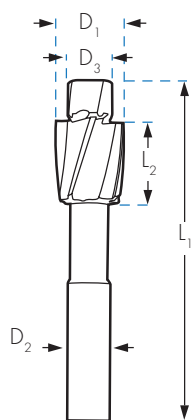

CORE HOLE
for counterboring
threaded holes



AV2M

AV2MM

AV2GM

ADJUSTMENT					AV2M		AV2MM		AV2GM				
	D1 mm	D2 mm	L1 mm	L2 mm	D3 mm	FINE €	D3 mm	MEDIUM €	D3 mm	THREADED HOLE €			
M3	6,0	5,0	71	14	AV2M3	3,2	24,84	AV2MM3	3,4	26,89	AV2GM3	2,5	26,89
M4	8,0	5,0	71	14	AV2M4	4,3	24,84	AV2MM4	4,5	26,89	AV2GM4	3,3	26,89
M5	10,0	8,0	80	18	AV2M5	5,3	24,84	AV2MM5	5,5	26,89	AV2GM5	4,2	26,89
M6	11,0	8,0	80	18	AV2M6	6,4	28,00	AV2MM6	6,6	30,31	AV2GM6	5,0	30,31
M7	20,0	12,7	90	20	AV2M7	7,4	51,70						
M8	15,0	12,5	100	22	AV2M8	8,4	34,71	AV2MM8	9,0	37,57	AV2GM8	6,8	37,57
M10	18,0	12,5	100	22	AV2M10	10,5	41,32	AV2MM10	11,0	44,73	AV2GM10	8,5	44,73
M11	22,0	18,8	100	22	AV2M11	11,5	55,00						
M12	20,0	12,5	100	22	AV2M12	13,0	48,20	AV2MM12	14,0	52,18	AV2GM12	10,2	52,18
M14	24,0	12,5	100	22	AV2M14	15,0	75,40	AV2MM14	15,5	81,62	AV2GM14	12,0	81,62
M16	26,0	12,5	100	22	AV2M16	17,0	82,93	AV2MM16	17,5	89,77	AV2GM16	14,0	89,77

STRAIGHT SHANK

DIN
1866
HSS

NOTE: The guide is not included in the cutting length.

Ref. AV3

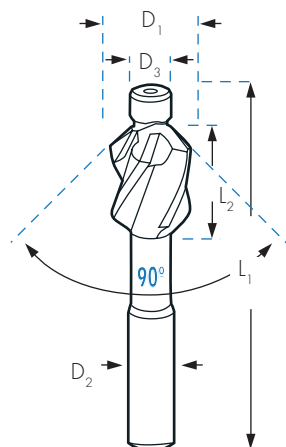

ADJUSTMENT					AV3		
	D1 mm	D2 mm	L1 mm	L2 mm	D3 mm	FINE €	
M3	6,3	6,0	71	14,0	AV3M3	3,2	33,98
M4	8,3	8,0	71	14,0	AV3M4	4,3	33,98
M5	10,4	10,0	80	18,0	AV3M5	5,3	33,98
M6	12,4	10,0	80	18,0	AV3M6	6,4	38,61
M8	16,5	12,0	100	22,0	AV3M8	8,4	47,25
M10	20,5	12,0	100	22,0	AV3M10	10,5	51,12
M12	24,5	13,0	110	25,0	AV3M12	13,0	62,31

HSS COUNTERBORES FOR ALLEN SCREWS

MORSE TAPER SHANK

Ref. AV5

**DIN
375**

HSS

NOTE: The guide is not included in the cutting length.

* The core hole is used for counterboring threaded holes.

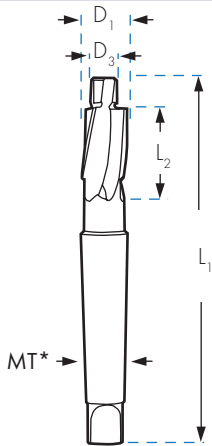

CORE HOLE
for counterboring
threaded holes



AV5M

AV5MM

AV5GM

ADJUSTMENT					FINE			MEDIUM			THREADED HOLE		
	D1 mm	MT*	L1 mm	L2 mm		D3 mm	€		D3 mm	€		D3 mm	€
M8	15,0	2	132	22	AV5M8	8,4	67,27	AV5MM8	9,0	67,27	AV5GM8	6,8	67,27
M10	18,0	2	140	25	AV5M10	10,5	69,04	AV5MM10	11,0	69,04	AV5GM10	8,5	69,04
M12	20,0	2	140	25	AV5M12	13,0	76,39	AV5MM12	14,0	76,39	AV5GM12	10,2	76,39
M14	24,0	2	150	30	AV5M14	15,0	106,03	AV5MM14	15,5	106,03	AV5GM14	12,0	106,03
M16	26,0	3	180	35	AV5M16	17,0	124,51	AV5MM16	17,5	124,51	AV5GM16	14,0	124,51
M18	30,0	3	180	35	AV5M18	19,0	134,35	AV5MM18	20,0	134,35	AV5GM18	15,5	134,35
M20	33,0	3	190	40	AV5M20	21,0	146,38	AV5MM20	22,0	146,38	AV5GM20	17,5	146,38
M22	36,0	3	190	40	AV5M22	23,0	178,38	AV5MM22	24,0	178,38	AV5GM22	19,5	178,38
M24	40,0	3	190	40	AV5M24	25,0	215,64	AV5MM24	26,0	215,64	AV5GM24	21,0	215,64
M27	46,0	4	255	50	AV5M27	30,0	245,03						
M30	48,0	4	255	50	AV5M30	33,0	296,43						

* Morse taper

ADJUSTMENT APPLICATIONS: FINE, MEDIUM AND THREADED HOLE

- T₁ : For allen screws DIN 84 and DIN 7984
For allen screws DIN 7513 B
For allen screws DIN 7500 B
- T₂ : For allen screws DIN 6912
- T₃ : For allen screws DIN 912

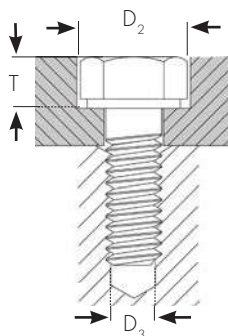

	FINE	MEDIUM	THREADED HOLE				
METRIC THREAD	D3 mm	D3 mm	D3 mm	D2 mm	T ₁ mm	T ₂ mm	T ₃ mm
M3	3,2	3,4	2,5	6,0	2,4	--	3,4
M4	4,3	4,5	3,3	8,0	3,2	3,4	4,6
M5	5,3	5,5	4,2	10,0	4,0	4,2	5,7
M6	6,4	6,6	5,0	11,0	4,7	4,8	6,8
M8	8,4	9,0	6,8	15,0	6,0	6,0	6,0
M10	10,5	11,0	8,5	18,0	7,0	7,5	11,0
M12	13,0	13,5	10,2	20,0	8,0	8,5	13,0
M14	15,0	15,5	12,0	24,0	9,0	9,5	15,0
M16	17,0	17,5	14,0	26,0	10,5	11,5	17,5
M18	19,0	20,0	15,5	30,0	11,5	12,5	19,5
M20	21,0	22,0	17,5	33,0	12,5	13,5	21,5
M22	23,0	24,0	19,5	36,0	13,5	14,5	23,5

COUNTERSINKS WITH INTERCHANGEABLES ELEMENTS FOR ALLEN AND TAPER CAP SCREWS

A SERIES

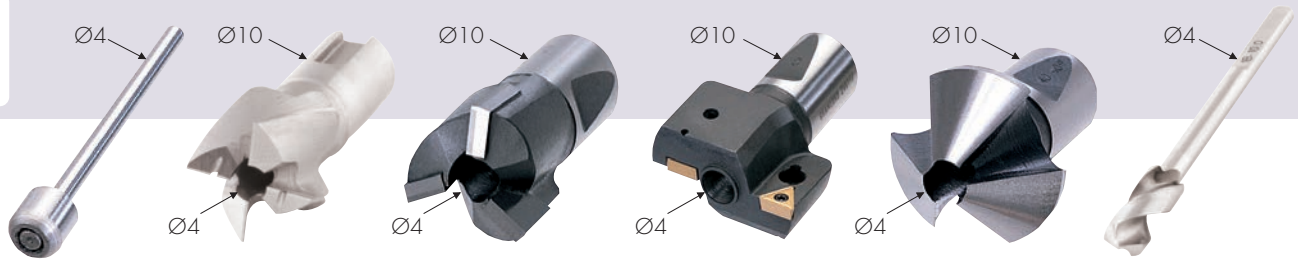

GUIDE COUNTERBORE COUNTERBORE INDEXABLE INSERTS COUNTERSINK DRILL

AGP		APAV		APAVMD		APAVPQ		AVC		ABP	
€	HSS €	CARBIDE €	Without insert	CARBIDE €	90° HSS €	HSS €					
										ABP0430	78,48
										ABP0450	78,48
										ABP0500	78,48
										ABP0530	78,48
										ABP0550	78,48
AGP0400	45,28									ABP0600	92,24
AGP0450	54,00	APAV0700	138,20					AVC0800	180,12	ABP0640	92,24
AGP0550	54,00	APAV0800	136,53							ABP0650	92,24
AGP0600	54,00	APAV0900	136,53								
AGP0650	54,00	APAV1000	132,16	APAVMD1000	388,14			AVC1000	180,12		
AGP0640	54,00										
AGP0660	54,00	APAV1100	136,53	APAVMD1100	388,14			AVC1200	182,81	ABP0660	92,24
AGP0500	54,00									ABP0700	92,24
		APAV1150	150,96								
		APAV1200	138,20	APAVMD1200	388,14			AVC1150	176,78		
		APAV1250	153,30					AVC1240	184,93		
		APAV1300	150,63	APAVMD1300	388,14						
		APAV1350	173,43					AVC1350	184,93		
		APAV1400	150,63	APAVMD1400	391,81			AVC1400	198,25		
		APAV1450	173,77								
AGP0840	54,69										
AGP0900	54,69	APAV1500	152,30	APAVMD1500	396,17			AVC1500	199,91		
AGP0680	54,00										
AGP0700	54,00	APAV1600	161,00	APAVMD1600	405,24			AVC1600	200,93		
AGP0750	54,00	APAV1700	164,07	APAVMD1700	413,97			AVC1650	195,58		
AGP0800	54,69	APAV1800	168,38	APAVMD1800	422,66	APAVPQ1800	882,90				
AGP0850	54,69	APAV1900	179,15	APAVMD1900	441,78						
AGP0900	54,69	APAV2000	185,51	APAVMD2000	451,19	APAVPQ2000	989,59				
AGP0950	54,69	APAV2100	202,29	APAVMD2100	472,63						
AGP1000	54,69										
AGP1050	54,69										
AGP1100	54,69										
AGP1150	54,69										

TOOL HOLDERS



APH						
	D1 mm	D2 mm	L1 mm	L2 mm	MT* Ømm	€
APHCM1	18	10	110	48	CM1	323,70
APHCM2	18	10	132	57	CM2	317,67
APH-10	18	10	92	42	Ø10	302,57

INDEXABLE INSERTS

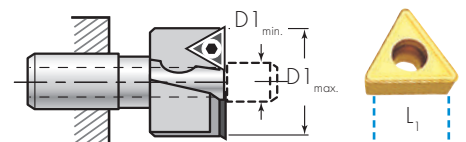

PPQ				
	L1 mm	D1 min. Ømm	D1 max. Ømm	€
PPQ07	7	18	20	33,55

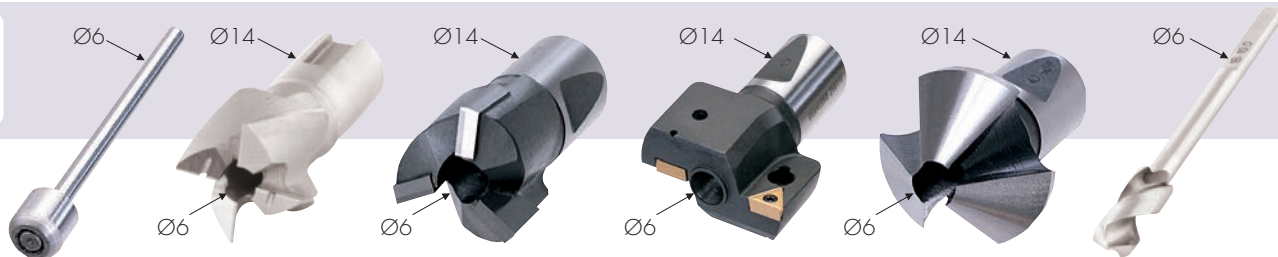
**COUNTERSINKS WITH INTERCHANGEABLES ELEMENTS FOR ALLEN
AND TAPER CAP SCREWS**
**B
SERIES**

GUIDE

COUNTERBORE

COUNTERBORE

INDEXABLE INSERTS

COUNTERSINK

DRILL

BGP		BPAV		BPAVMD		BPAVPQ		BVC		BBP	
€	HSS €	CARBIDE €	Without insert	CARBIDE €	90° HSS €	HSS €					
		BPAV1300 152,97	BPAVMD1300 413,97								
		BPAV1350 172,74									
		BPAV1400 152,97	BPAVMD1400 413,97								
		BPAV1450 172,74									BBP0800 109,70
BGP0840 50,99											
BGP0900 50,99	BPAV1500 152,97	BPAVMD1500 413,97			BVC15 189,87					BBP0900 109,70	
BGP0680 50,99											
BGP0800 50,99											
BGP1000 50,99	BPAV1550 175,10										
BGP1150 54,00	BPAV1600 161,37	BPAVMD1600 429,37								BBP0840 109,70	
BGP1250 56,02	BPAV1650 187,17									BBP0850 109,70	
BGP1350 61,72	BPAV1700 168,05	BPAVMD1700 429,37								BBP0950 109,70	
BGP1450 62,38	BPAV1750 188,50									BBP1000 125,12	
	BPAV1900 193,89	BPAVMD1900 433,09								BBP1050 125,12	
BGP1050 54,00											
BGP1100 54,00	BPAV1800 174,44	BPAVMD1800 433,09					BVC20 214,68			BBP1100 125,12	
BGP0850 50,99											
BGP1300 61,72											
BGP1400 62,38	BPAV2000 193,89	BPAVMD2000 446,49	BPAVPQ2000 883,64	BVC25 223,43							
BGP1020 54,00											
BGP1500 62,38											
BGP1550 62,38	BPAV2400 229,13	BPAVMD2400 474,34	BPAVPQ2400 884,78	BVC28 259,97							
BGP1200 54,00											
BGP1700 62,38											
BGP1750 62,38	BPAV2600 244,87	BPAVMD2600 477,02	BPAVPQ2600 1.014,46	BVC30 265,69							
BGP1400 62,38											
BGP1900 63,73											
BGP2000 79,50	BPAV3000 330,75	BPAVMD3000 520,30	BPAVPQ3000 1.014,46								
	BPAV3400 391,12	BPAVMD3400 600,08	BPAVPQ3400 1.170,92								

TOOL HOLDERS

	D ₁ mm	D ₂ mm	L ₁ mm	L ₂ mm	MT* Ømm	BPH €
BPHCM1	24	14	123	62	CM1	358,95
BPHCM2	24	14	137	62	CM2	327,74
BPHCM3	24	14	160	66	CM3	358,95
BPH-12	24	14	120	55	Ø12	324,03

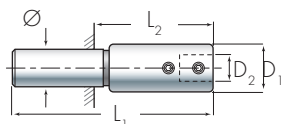
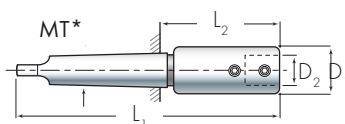
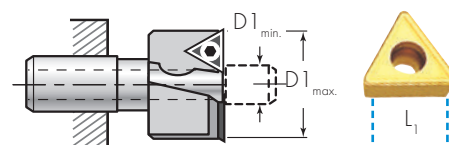
INDEXABLE INSERTS

	L1 mm	D1 _{min.} Ømm	D1 _{max.} Ømm	PPQ €
PPQ07	7	20	25	33,55
PPQ10	10	26	33	30,20
PPQ12	12	34	36	30,20

COUNTERSINKS WITH INTERCHANGEABLES ELEMENTS FOR ALLEN AND TAPER CAP SCREWS

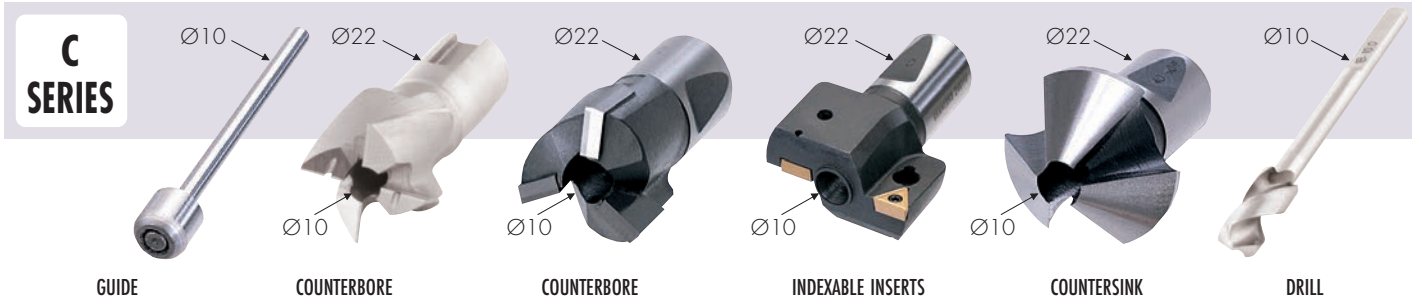

CGP		CPAV		CPAVMD		CPAVPQ		CVC		CBP	
€	HSS €	CARBIDE €	Without insert	CARBIDE €	90° HSS €	HSS €					
CGP1200	58,03	CPAV2300	277,75	CPAVMD2300	517,59						
CGP1250	58,03	CPAV2400	281,42	CPAVMD2400	512,22						
CGP1300	58,03	CPAV2500	304,27	CPAVMD2500	513,24						
CGP1350	58,03	CPAV2600	310,30	CPAVMD2600	527,33						
CGP1400	68,10	CPAV2700	314,65								
CGP1450	68,10	CPAV2800	320,69	CPAVMD2800	532,36					CBP1700	274,08
CGP1500	68,10	CPAV2900	328,40							CBP1800	308,94
CGP1600	68,10	CPAV3100	356,92							CBP1900	324,03
CGP1650	68,10	CPAV3200	368,66	CPAVMD3200	581,33					CBP2100	351,23
CGP1700	68,10	CPAV3300	372,00							CBP2300	422,66
CGP1900	68,10										
CGP2000	68,10	CPAV3000	332,75	CPAVMD3000	587,04			CVC35	387,44	CBP2000	351,23
CGP1550	68,10										
CGP2100	75,82										
CGP2200	75,82	CPAV3400	375,73	CPAVMD3400	623,94	CPAVPQ3400	1.210,86	CVC37	409,92	CBP2200	391,81
CGP1750	68,10										
CGP1850	68,10	CPAV3500	393,49								
CGP2300	75,82										
CGP2400	75,82	CPAV3600	398,19	CPAVMD3600	641,04	CPAVPQ3600	1.210,86	CVC37	409,92	CBP2400	431,75
CGP1950	68,10										
CGP2500	75,82										
CGP2600	93,24	CPAV4000	462,26	CPAVMD4000	710,14	CPAVPQ4000	1.238,76	CVC40	435,75		
CGP2100	75,82										
CGP2200	75,82	CPAV4500	570,27			CPAVPQ4500	1.261,38				
CGP2050	75,82	CPAV5000	828,23			CPAVPQ5000	1.475,89				
		CPAV5500	872,50			CPAVPQ5500	1.743,16				
		CPAV6000	919,46			CPAVPQ6000	1.743,16				
		CPAV6500	1.034,20			CPAVPQ6500	1.993,47				

TOOL HOLDERS



	D ₁ mm	D ₂ mm	L ₁ mm	L ₂ mm	MT* Ømm	CPH €
CPHCM2	36	22	160	85	CM2	472,63
CPHCM3	36	22	180	87	CM3	446,49
CPHCM4	36	22	206	89	CM4	500,49
CPHCM5	36	22	240	91	CM5	1.101,30
CPH-12	36	22	140	71	Ø20	324,03

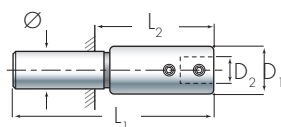
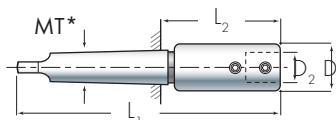

INDEXABLE INSERTS

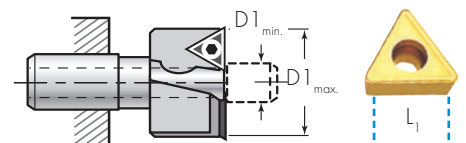

	L ₁ mm	D ₁ min. Ømm	D ₁ max. Ømm	PPQ €
PPQ12	12	34	45	30,20
PPQ17	17	<46		46,80

STEP DRILLS AND TUBE & SHEET DRILL SETS
HSS & HSSCo TUBE AND SHEET DRILL SETS
HSS

(Ref. AV30 drills)

AV30BM0 AV30BM1 AV30BM2

REFERENCE	AV30BM012	
QUANTITY	3	
QUALITY	HSS	
CONTENT	AV30BM0 - AV30BM1 - AV30BM2 (3-14mm) (6-20mm) (16-30mm)	
PRICE €	HSS	115,47
€	HSS	TiN
		219,14

HSSCo

(Ref. AVC30 drills)

AVC30BM0 AVC30BM1 AVC30BM2

REFERENCE	AVC30BM012	
QUANTITY	3	
QUALITY	HSSCo	
CONTENT	AVC30BM0 - AVC30BM1 - AVC30BM2 (3-14mm) (6-20mm) (16-30mm)	
PRICE €	HSS Co	166,34
€	HSS Co	TiN
		234,33

HSS SPIRAL FLUTED STEP DRILL SETS
HSS

(Ref. AV42 drills)

AV42BM2 AV42BM3 AV42BM4

REFERENCE	AV42BM234	
QUANTITY	3	
QUALITY	HSS	
CONTENT	AV42BM2 - AV42BM3 - AV42BM4	
PRICE €	HSS	317,53
€	HSS	TiN
		397,93



STEP DRILL SETS

HSS STRAIGHT FLUTED STEP DRILL SETS

HSS



AV40BM2 AV40BM3 AV40BM4 AV40BM5 AV40BM13



PAV40BM234



PAV40BM235



PAV40BM2313

(Ref. AV40 drills)

REFERENCE	PAV40BM234	PAV40BM235	PAV40BM2313
QUANTITY	3	3	3
CONTENT	AV40BM2 - AV40BM3 - AV40BM4 (4-12mm) (4-20mm) (4-30mm)	AV40BM2 - AV40BM3 - AV40BM5 (4-12mm) (4-20mm) (6-38mm)	AV40BM2 - AV40BM3 - AV40BM13 (4-12mm) (4-20mm) (6-40mm)
PRICE €	186,80	232,75	286,06
€	HSS TiN	HSS TiN	HSS TiN
	305,67	347,55	416,77



AV40BM234



AV40BM22122

(Ref. AV40 drills)

REFERENCE	AV40BM234	AV40BM22122
QUANTITY	3	3
CONTENT	AV40BM2 - AV40BM3 - AV40BM4 (4-12mm) (4-20mm) (4-30mm)	AV40BM2 - AV40BM21 - AV40BM22 (4-12mm) (7+10-20mm) (10+20-30mm)
PRICE €	186,80	278,70
€	HSS TiN	HSS TiN
	305,67	403,89

(Ref. AVC40 drills)

REFERENCE	AVC40BM234
QUANTITY	3
CONTENT	AVC40BM2 - AVC40BM3 - AVC40BM4 (4-12mm) (4-20mm) (4-30mm)
PRICE €	291,82
€	HSS Co TiN
	402,89

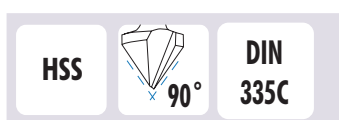
COUNTERSINKS SETS

(Ref. AV6 Countersink)

REFERENCE	AV6CM1	AV6CM2	AV6CM3	PAV6CM2
QUANTITY	6	6	7	6
CONTENT	Ø 6 - 8 - 10 - 11,5 - 15 - 19 mm	Ø 6,3 - 8,3 - 10,4 - 12,4 - 16,5 - 20,5 mm	Ø 6,3 - 8,3 - 10,4 - 12,4 - 16,5 - 20,5 - 25 mm	Ø 6,3 - 8,3 - 10,4 - 12,4 - 16,5 - 20,5 mm
PRICE €	154,90	135,69	228,38	135,69



(Ref. AV7 Countersink)

REFERENCE	AV7CM1	AV7CM2	AV7CM3	PAV7CM2
QUANTITY	6	6	7	6
CONTENT	Ø 6 - 8 - 10 - 11,5 - 15 - 19 mm	Ø 6,3 - 8,3 - 10,4 - 12,4 - 16,5 - 20,5 mm	Ø 6,3 - 8,3 - 10,4 - 12,4 - 16,5 - 20,5 - 25 mm	Ø 6,3 - 8,3 - 10,4 - 12,4 - 16,5 - 20,5 mm
PRICE €	162,45	162,04	248,65	162,04

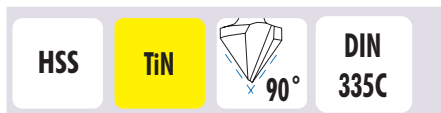

(Ref. AV16 Countersink)

REFERENCE	AV16CM1	AV16CM2	AV16CM3
QUANTITY	6	6	7
CONTENT	Ø 6 - 8 - 10 - 11,5 - 15 - 19 mm	Ø 6,3 - 8,3 - 10,4 - 12,4 - 16,5 - 20,5 mm	Ø 6,3 - 8,3 - 10,4 - 12,4 - 16,5 - 20,5 - 25 mm
PRICE €	282,86	288,76	403,03



(Ref. AV8 Countersink)

REFERENCE	AV8CM2	AV8CM3
QUANTITY	6	7
CONTENT	Ø 6,3 - 8 - 10 - 12,5 - 16 - 20 mm	Ø 6,3 - 8 - 10 - 12,5 - 16 - 20 - 25 mm
PRICE €	211,13	272,95

* Other boxes on request AV99, etc...

METALLIC COUNTERSINK SETS

HSS  **CELESA NORM**



(Ref. AV9 Countersink)

REFERENCE	AV9CM1	AV9CM5
QUANTITY	6	7
CONTENT	Ø 6,3 - 8,3 - 10,4 - 12,4 - 16,5 - 20,5 mm	Ø 6,3 - 8,3 - 10,4 - 12,4 - 16,5 - 20,5 - 25 mm
PRICE €	215,94	279,44



HSS  **CELESA NORM**



(Ref. AV10 Countersink)

REFERENCE	AV10CM1	AV10CM6
QUANTITY	6	7
CONTENT	Ø 6,3 - 8,3 - 10,4 - 12,4 - 16,5 - 20,5 mm	Ø 6,3 - 8,3 - 10,4 - 12,4 - 16,5 - 20,5 - 25 mm
PRICE €	242,94	300,72



* Other boxes on request AV99, etc...

HSS & HSSCo 90° DEBURRING COUNTERSINK SETS

 **90°**

HSS

(Ref. AV1 Countersink)

REFERENCE	AV1S2*
QUANTITY	5
CONTENT	Ø 10 - 14 - 20 - 27 - 30 mm
PRICE €	305,53*

HSSCo

(Ref. AV2 Countersink)

REFERENCE	AV2S2*
QUANTITY	5
CONTENT	Ø 10 - 14 - 20 - 27 - 30 mm
PRICE €	384,57*
€	HSS Co TiN
	513,48*

HSS STRAIGHT SHANK COUNTERBORES FOR ALLEN SCREW IN METAL SETS

HSS **DIN 373**

FINE

MEDIUM

CORE

(Ref. AV2M Countersink)

(Ref. AV2MM Countersink)

(Ref. AV2GM Countersink)

REFERENCE	AV2M3-10	AV2M3-10M	AV2M3-10G
QUANTITY	6		
CONTENT	M3 - M4 - M5 - M6 - M8 - M10		
PRICE €	182,38	197,45	197,45

REFERENCE	AV2M3-12	AV2M3-12M	AV2M3-12G
QUANTITY	7		
CONTENT	M3 - M4 - M5 - M6 - M8 - M10 - M12		
PRICE €	234,23	253,56	253,56



Ref. AV2M3-10

PRECISION DEBURRING TOOLS

BLUEMASTER DEBURRING TOOL

Deburring Tools remove chip and burrs created around the edge and corners in every piece made of metal, plastic and wood. They are made of three pieces: BLADE + BLADE HOLDER + UNIVERSAL HANDLE

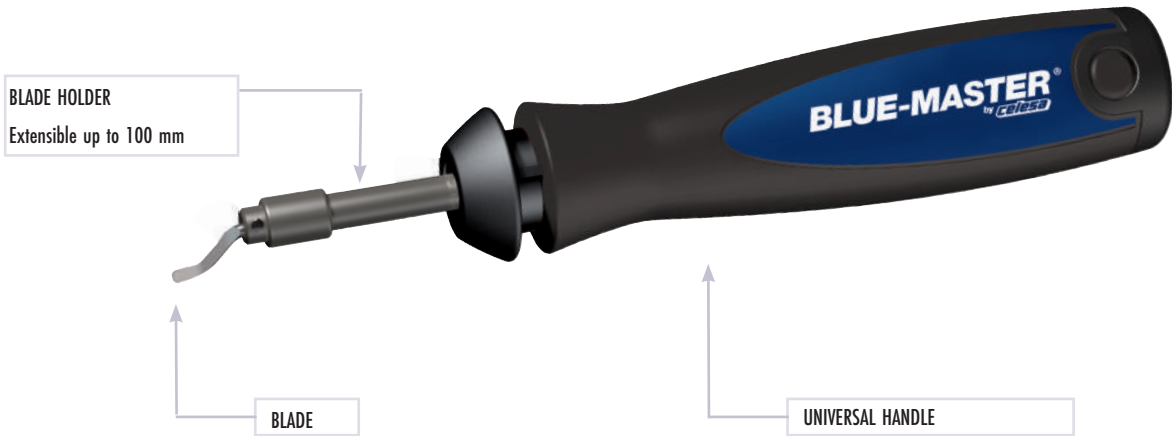

B SET

JRB1

Content B:

Ref. RB10			Ref. RBB1
Ref. RB20			Ref. RBB

Blister: **32,65 €**

C SET

JRB2

Content C:

		Ref. RBB1
Ref. RC42		Ref. RBC

Blister: **59,46 €**

D SET

JRB3

Content D:

		Ref. RBB1
Ref. RD80MD		Ref. RBD

Blister: **93,73 €**

E SET

JRB4

Content E:

		Ref. RBB1
Ref. RE10		Ref. RBE
Ref. RE20		
Ref. RE30		

Blister: **36,36 €**



PRECISION DEBURRING TOOLS

GROUP B

BLADE HOLDER GROUP B



Ø2,6mm

Valid for deburring blades Group B

RBB

Blister 1 U.: **11,46 €**

BLADES GROUP B



Deburring blade
Short series: Steel, Aluminium, Plastic

RB10*

Blister 10 U.: **2,12 €/U.**



Punching carbide tipped blade

RB50*

Blister 1 U.: **37,72 €**



Bidirectional deburring blade
Short series: Brass, Cast iron

RB20

Blister 10 U.: **2,12 €/U.**



Long blade used for
deburring till 20 mm. depth
back-edge created after drilling.

RB60*

Blister 10 U.: **5,01 €/Ud**



Double edge deburring blade
4 mm. depth holes

RB30

Blister 10 U.: **2,12 €/Ud**



Outside edges deburring blade

RB70MD*

Blister 1 U.: **42,91 €**

GROUP C

BLADE HOLDER GROUP C



Valid for deburring blades Group C

RBC

Blister 1 U.: **11,46 €**

BLADES GROUP C



RC40*

Blister 1 U.: **23,36 €**



RC42*

Blister 1 U.: **29,06 €**

*Till end of stock

GROUP D

BLADE HOLDER GROUP D



Valid for deburring blades Group D

RBD

Blister 1 U.: **11,46 €**

BLADES GROUP D



Solid carbide blade used in "V" shaped
edges till 3 mm. (6 Working edges).

RD80MD*

Blister 1 U.: **61,07 €**



Solid carbide blade used in "V" shaped
edges till 8 mm. (2 Working edges).

RD82MD*

Blister 1 U.: **95,74 €**

*Till end of stock

UNIVERSAL HANDLE

General uses
Valid for the following blade holders:
RBB / RBC / RBD / RBE / RBF



RBB1
Blister 1 ud.: 15,06 €

PRECISION DEBURRING TOOLS

GROUP E

BLADE HOLDER GROUP E



∅3,2mm

Valid for deburring blades Group E

RBE
Blister 1 ud.: 11,46 €

BLADES GROUP E



Deburring blade for inside & outside
Long series: Steel, Aluminium, Plastic

RE10
Blister 10 ud.: 2,59 €/Ud



Valid for 90° edges: Keyways,...

RE35
Blister 10 ud.: 2,78 €/Ud



Bidirectional deburring blade
Long series: Brass, Cast iron

RE20
Blister 10 ud.: 2,59 €/Ud



Double edge closed deburring blade for 4 mm. depth holes.

RE30
Blister 10 ud.: 2,59 €/Ud



Long blade used for deburring till 20mm depth back-edge created after drilling.

RE60*
Blister 5 ud.: 3,64 €/Ud

GROUP F

BLADE HOLDER GROUP F



Valid for deburring blades Group F

RBF
Blister 1 ud.: 11,46 €

BLADES GROUP F (Thread M05 x 0,80)

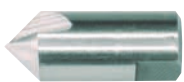

HSS counterbore blade 12 mm.

RF12
Blister 1 ud.: 25,78 €

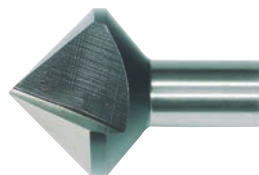

HSS counterbore blade 30 mm.

RF30
Blister 1 ud.: 86,14 €

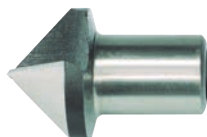

HSS counterbore blade 20 mm.

RF20
Blister 1 ud.: 49,83 €