

BLUE-MASTER®
by *celesa*

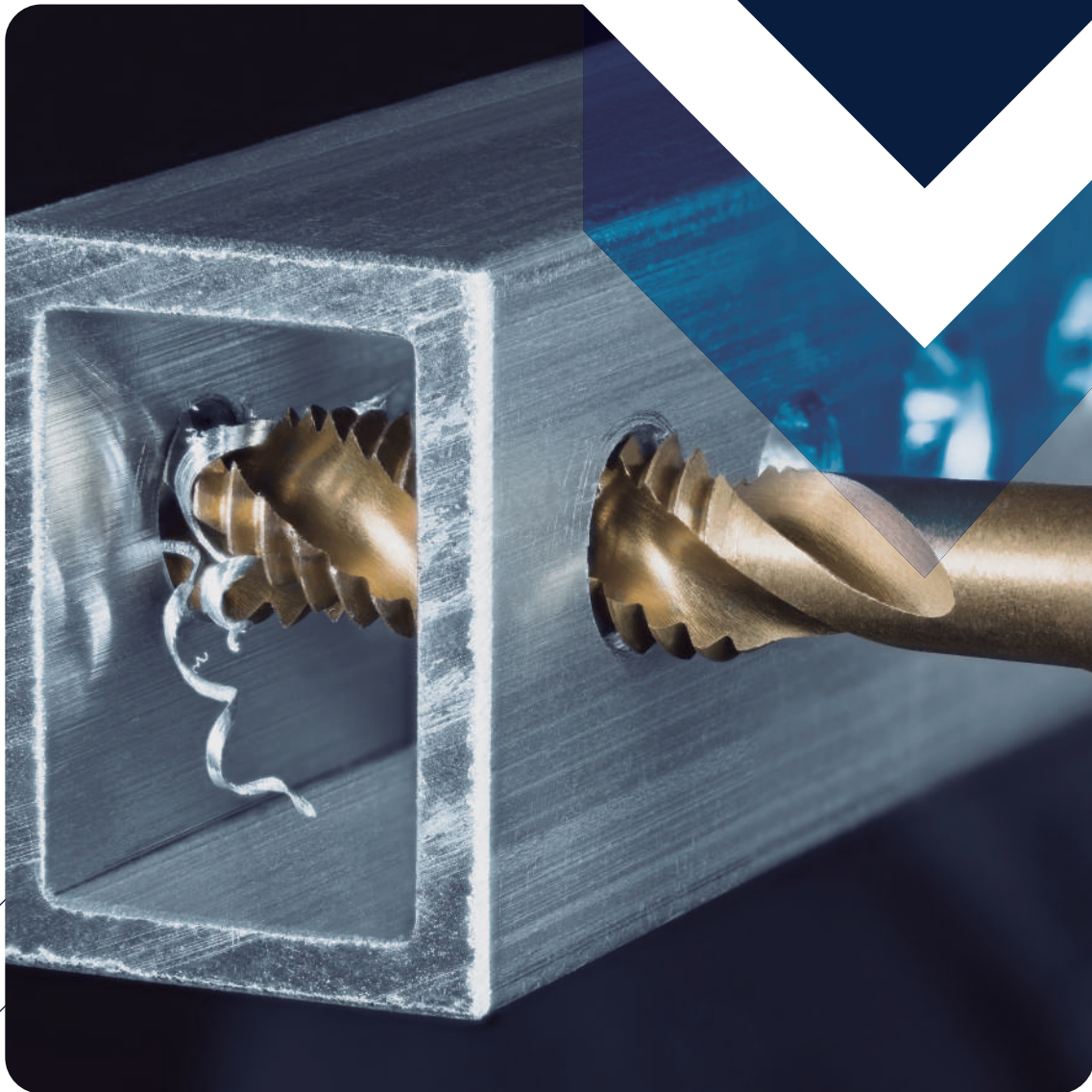
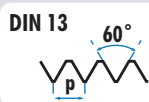

MASCHI
E FILIERE

SERIE DI MASCHI E FILIERE PER FILETTARE A MANO HSS

Ref. MO

HSS

DIN
352DIN
2181TOL
6H

Ref. C5

HSS

DIN
223TOL
6g

Per materiali fino a 38 HRC.



		MO			C5		
	U.tà		L1 x L2 x mm	€	Ø x L3 mm	€	
M 5,5x0,90	3	4,60	50 x 16 x 4,9	85,98	25 x 9	24,84	
M 6x0,50	2	5,50	50 x 14 x 4,9	27,77	20 x 5	30,60	
M 6x0,75	2	5,25	50 x 14 x 4,9	23,39	25 x 9	27,39	
M 6x1,00	3	5,00	50 x 19 x 4,9	17,10*	25 x 9	19,30*	
M 6x1,25	3	4,75	50 x 19 x 4,9	134,35	25 x 9	108,33	
M 7x0,75	2	6,25	50 x 14 x 4,9	28,35	25 x 9	32,33	
M 7x1,00	3	6,00	50 x 19 x 4,9	22,54*	25 x 9	25,52*	
M 7x1,25	3	5,75	50 x 19 x 4,9	98,01	25 x 9	130,19	
M 8x0,50	2	7,50	50 x 16 x 4,9	33,30	25 x 9	32,33	
M 8x0,75	2	7,25	50 x 16 x 4,9	28,75	25 x 9	27,80	
M 8x1,00	2	7,00	56 x 18 x 4,9	21,26*	25 x 9	27,80*	
M 8x1,25	3	6,80	56 x 22 x 4,9	18,69*	25 x 9	19,71*	
M 8x1,50	3	6,50	56 x 22 x 4,9	95,35	25 x 9	116,42	
M 9x1,00	2	8,00	63 x 18 x 5,5	31,49	25 x 9	39,21	
M 9x1,25	3	7,80	63 x 22 x 5,5	25,37*	25 x 9	29,12*	
M 10x0,50	2	9,50	63 x 18 x 5,5	51,07	30 x 10	94,01	
M 10x0,75	2	9,25	63 x 18 x 5,5	44,33	30 x 11	39,22	
M 10x1,00	2	9,00	63 x 18 x 5,5	25,01	38 x 10	32,33	
M 10x1,25	2	8,80	70 x 24 x 5,5	23,29	38 x 10	32,34	
M 10x1,50	3	8,50	70 x 24 x 5,5	24,07*	38 x 10	22,56*	
M 11x0,75	2	10,25	63 x 18 x 6,2	80,48	30 x 11	128,97	
M 11x1,00	2	10,00	63 x 18 x 6,2	40,99	30 x 11	44,02	
M 11x1,25	2	9,75	63 x 20 x 6,2	40,99	30 x 11	45,15	
M 11x1,50	3	9,50	70 x 24 x 6,2	51,49	38 x 10	33,25	
M 12x0,75	2	11,25	70 x 20 x 7,0	40,72	38 x 10	45,76	
M 12x1,00	2	11,00	70 x 20 x 7,0	40,97	38 x 10	39,21	
M 12x1,25	2	10,75	70 x 20 x 7,0	40,84	38 x 10	39,21	
M 12x1,50	2	10,50	70 x 20 x 7,0	37,68*	38 x 10	38,18*	
M 12x1,75	3	10,20	75 x 29 x 7,0	30,33*	38 x 14	32,64*	
M 13x0,75	2	12,25	70 x 20 x 9,0	82,71	38 x 10	121,66	
M 13x1,00	2	12,00	70 x 20 x 9,0	63,98	38 x 10	50,20	
M 13x1,25	2	11,75	70 x 20 x 9,0	66,02	38 x 10	83,39	
M 13x1,50	2	11,50	70 x 20 x 9,0	62,91	38 x 10	50,17	
M 13x1,75	3	11,25	70 x 20 x 9,0	81,68	38 x 14	75,67	
M 14x0,75	2	13,25	70 x 20 x 9,0	64,26	38 x 10	51,51	
M 14x1,00	2	13,00	70 x 20 x 9,0	63,63	38 x 10	49,57	
M 14x1,25	2	12,80	70 x 20 x 9,0	47,47*	38 x 10	44,13*	
M 14x1,50	2	12,50	70 x 20 x 9,0	40,67	38 x 10	44,13	
M 14x1,75	2	12,25	70 x 20 x 9,0	83,51	38 x 14	187,47	
M 14x2,00	3	12,00	80 x 30 x 9,0	39,05*	38 x 14	35,61*	
M 15x1,00	2	14,00	70 x 20 x 9,0	68,99	45 x 14	66,76	
M 15x1,25	2	13,75	70 x 20 x 9,0	98,51	45 x 14	113,94	
M 15x1,50	2	13,50	70 x 20 x 9,0	69,67	45 x 14	64,19	
M 15x2,00	3	13,00	80 x 30 x 9,0	100,91	45 x 14	98,63	
M 16x1,00	2	15,00	70 x 20 x 9,0	69,40	45 x 14	64,18	
M 16x1,25	2	14,75	70 x 20 x 9,0	69,82	45 x 14	68,59	
M 16x1,50	2	14,50	70 x 20 x 9,0	50,01*	45 x 14	52,33*	
M 16x2,00	3	14,00	80 x 32 x 9,0	46,83*	45 x 18	41,77*	
M 17x1,00	2	16,00	70 x 20 x 9,0	149,53	45 x 14	116,74	
M 17x1,25	2	15,75	70 x 20 x 9,0	149,53	45 x 14	121,42	
M 17x1,50	2	15,50	70 x 20 x 9,0	149,53	45 x 14	116,74	
M 18x1,00	2	17,00	80 x 22 x 11,0	74,89	45 x 14	60,21	
M 18x1,25	2	16,75	80 x 22 x 11,0	77,74	45 x 14	64,34	

* Consultare il prezzo delle serie di maschi e filiere a sinistra disponibili a Pag.188

* Sovraprezzo per le filiere regolabili pari al 20% del prezzo.

SERIE DI MASCHI E FILIERE PER FILETTARE A MANO HSS

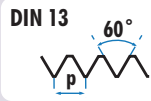

Ref. MO

	(M)	(MF)	
HSS	DIN 352	DIN 2181	TOL 6H

Ref. C5

HSS	DIN 223	TOL 6g
-----	---------	--------

		MO					C5										
U.ità	Ø	L1 x L2 x mm	€	Ø x L3 mm	€	U.ità	Ø	L1 x L2 x mm	€	Ø x L3 mm	€	U.ità	Ø	L1 x L2 x mm	€	Ø x L3 mm	€
M 18x1,50	2	16,50	80 x 22 x 11,0	51,02	45 x 14	54,42	M 33x3,50	3	29,5	125 x 50 x 20,0	315,78*	65 x 25	118,43*				
M 18x2,00	2	16,00	80 x 22 x 11,0	75,58*	45 x 14	61,83*	M 34x1,50	2	32,5	100 x 25 x 22,0	327,32	65 x 18	150,10				
M 18x2,50	3	15,50	95 x 40 x 11,0	62,22*	45 x 18	47,44*	M 34x2,00	2	32,0	100 x 25 x 22,0	359,55	65 x 18	342,62				
M 19x1,00	2	18,00	80 x 22 x 11,0	217,00	45 x 14	147,59	M 35x1,50	2	33,5	100 x 25 x 22,0	314,81	65 x 18	141,37				
M 19x1,25	2	17,75	80 x 22 x 11,0	217,00	45 x 14	173,60	M 35x2,00	2	33,0	100 x 25 x 22,0	396,48	65 x 18	285,90				
M 19x1,50	2	17,50	80 x 22 x 11,0	217,00	45 x 14	147,59	M 36x1,50	2	34,5	100 x 25 x 22,0	350,85	65 x 18	141,38				
M 19x2,00	2	17,00	80 x 22 x 11,0	241,64	45 x 14	175,35	M 36x2,00	2	34,0	125 x 33 x 22,0	393,10	65 x 18	141,38				
M 20x1,00	2	19,00	80 x 22 x 12,0	97,32	45 x 14	60,21	M 36x3,00	2	33,0	125 x 33 x 22,0	427,88*	65 x 25	141,37*				
M 20x1,25	2	18,75	80 x 22 x 12,0	92,96	45 x 14	178,32	M 36x4,00	3	32,0	150 x 53 x 22,0	391,73*	65 x 25	118,46*				
M 20x1,50	2	18,50	80 x 22 x 12,0	55,27	45 x 14	52,95	M 38x1,50	2	36,5	100 x 25 x 22,0	405,50	75 x 20	227,93				
M 20x2,00	2	18,00	80 x 22 x 12,0	97,15*	45 x 14	60,21*	M 38x2,00	2	36,0	125 x 25 x 22,0	491,91	75 x 20	332,74				
M 20x2,50	3	17,50	95 x 40 x 12,0	68,68*	45 x 18	46,14*	M 39x1,50	2	37,5	110 x 25 x 24,0	486,98	75 x 20	221,48				
M 21x1,00	2	20,00	80 x 22 x 12,0	272,79	45 x 14	74,24	M 39x2,00	2	37,0	125 x 23 x 24,0	486,98	75 x 20	221,46				
M 21x1,25	2	19,75	80 x 22 x 12,0	272,79	45 x 14	188,04	M 39x3,00	2	36,0	125 x 33 x 24,0	481,49*	75 x 30	221,48*				
M 21x1,50	2	19,50	80 x 22 x 12,0	107,37	45 x 14	94,19	M 39x4,00	3	35,0	150 x 53 x 24,0	443,31*	75 x 30	183,58*				
M 22x1,00	2	21,00	80 x 22 x 14,5	96,94	55 x 16	110,60	M 40x1,50	2	38,5	110 x 25 x 24,0	476,20	75 x 20	252,16				
M 22x1,25	2	20,75	80 x 22 x 14,5	110,94	55 x 16	180,24	M 40x2,00	2	38,0	125 x 33 x 24,0	475,83	75 x 20	258,29				
M 22x1,50	2	20,50	80 x 22 x 14,5	80,66	55 x 16	95,14	M 40x3,00	2	37,0	125 x 33 x 24,0	474,07	75 x 30	221,46				
M 22x2,00	2	20,00	80 x 22 x 14,5	94,26*	55 x 16	105,86*	M 42x1,50	2	40,5	110 x 25 x 24,0	475,54	75 x 20	221,48				
M 22x2,50	3	19,50	100 x 40 x 14,5	96,05*	55 x 22	84,62*	M 42x2,00	2	40,0	125 x 33 x 24,0	508,05	75 x 20	172,69				
M 23x1,00	2	22,00	80 x 22 x 14,5	280,43	55 x 16	195,56	M 42x3,00	2	39,0	125 x 33 x 24,0	503,26	75 x 30	221,48				
M 23x1,50	2	21,50	80 x 22 x 14,5	126,26	55 x 16	216,67	M 42x4,50	3	37,5	150 x 53 x 24,0	622,17	75 x 30	183,59				
M 24x1,00	2	23,00	90 x 22 x 14,5	124,64	55 x 16	107,87	M 45x1,50	2	43,5	110 x 25 x 29,0	549,82	90 x 22	353,85				
M 24x1,25	2	22,75	90 x 22 x 14,5	125,80	55 x 16	143,21	M 45x2,00	2	43,0	125 x 33 x 29,0	559,98	90 x 22	351,31				
M 24x1,50	2	22,50	90 x 22 x 14,5	95,51	55 x 16	96,94	M 45x3,00	2	42,0	125 x 33 x 29,0	559,98	90 x 36	351,28				
M 24x2,00	2	22,00	90 x 22 x 14,5	128,44*	55 x 16	107,87*	M 45x4,50	3	40,5	160 x 60 x 29,0	718,25	90 x 36	316,75				
M 24x3,00	3	21,00	110 x 50 x 14,5	111,29*	55 x 22	84,62*	M 48x1,50	2	46,5	140 x 33 x 29,0	619,63	90 x 22	351,31				
M 25x1,00	2	24,00	90 x 22 x 14,5	187,09	55 x 16	163,71	M 48x2,00	2	46,0	140 x 33 x 29,0	677,25	90 x 22	351,30				
M 25x1,25	2	23,75	90 x 22 x 14,5	328,70	55 x 16	215,55	M 48x3,00	2	45,0	140 x 33 x 29,0	678,59	90 x 36	351,28				
M 25x1,50	2	23,50	90 x 22 x 14,5	193,92	55 x 16	140,82	M 48x5,00	3	43,0	180 x 65 x 29,0	821,55	90 x 36	304,58				
M 25x2,00	2	23,00	90 x 22 x 14,5	388,97	55 x 16	209,57	M 50x1,50	2	48,5	140 x 33 x 29,0	671,32	90 x 22	353,85				
M 26x1,00	2	25,00	90 x 22 x 14,5	188,45	55 x 16	162,26	M 50x3,00	2	57,0	140 x 33 x 29,0	721,45	90 x 22	339,49				
M 26x1,50	2	24,50	90 x 22 x 14,5	182,77	55 x 16	130,81	M 52x1,50	2	50,5	140 x 33 x 32,0	705,65	90 x 22	318,09				
M 26x2,00	2	24,00	90 x 22 x 14,5	189,29	55 x 16	183,36	M 52x2,00	2	50,0	140 x 33 x 32,0	869,88	90 x 22	369,66				
M 27x1,00	2	26,00	90 x 22 x 16,0	189,31	65 x 18	145,96	M 52x3,00	2	49,0	140 x 33 x 32,0	877,67	90 x 36	403,40				
M 27x1,50	2	25,50	90 x 22 x 16,0	192,82	65 x 18	146,59	M 52x5,00	3	47,0	180 x 65 x 32,0	1.040,83	90 x 36	315,49				
M 27x2,00	2	25,00	90 x 22 x 16,0	230,07*	65 x 18	159,43*	M 56x4,00	2	52,0	180 x 47 x 32,0	1.031,04	105 x 36					
M 27x3,00	3	24,00	110 x 50 x 16,0	144,87*	65 x 25	128,35*	M 56x5,50	3	50,5	200 x 85 x 35,0	1.376,26	105 x 36					
M 28x1,00	2	27,00	90 x 22 x 16,0	227,61	65 x 18	188,68	M 60x5,50	3	54,5	200 x 85 x 35,0	1.790,02	105 x 36					
M 28x1,50	2	26,50	90 x 22 x 16,0	203,06	65 x 18	132,89	M 64x4,00	2	60,0	180 x 50 x 35,0	1.683,20	120 x 36					
M 28x2,00	2	26,00	90 x 22 x 16,0	226,30	65 x 18	186,83	M 64x6,00	3	58,0	220 x 90 x 39,0	2.078,47	120 x 36					
M 30x1,00	2	29,00	90 x 22 x 18,0	227,62	65 x 18	154,68	M 68x6,00	3	62,0	220 x 90 x 39,0	2.535,73	120 x 36					
M 30x1,50	2	28,50	90 x 22 x 18,0	216,40	65 x 18	157,08	M 72x6,00	3	66,0	235 x 90 x 39,0	2.747,16	120 x 36					
M 30x2,00	2	28,00	90 x 22 x 18,0	249,48	65 x 18	141,38											
M 30x3,00	2	27,00	125 x 56 x 18,0	243,88*	65 x 25	113,39*											
M 30x3,50	3	26,50	125 x 50 x 18,0	183,58*	65 x 25	118,46*											
M 32x1,00	2	31,00	90 x 22 x 18,0	332,84	65 x 18	213,78											
M 32x1,50	2	30,50	90 x 22 x 18,0	267,12	65 x 18	141,37											
M 32x2,00	2	30,00	90 x 22 x 18,0	333,40	65 x 18	113,40											
M 33x1,00	2	32,00	100 x 25 x 20,0	505,88	65 x 18	230,99											
M 33x1,50	2	31,50	100 x 25 x 20,0	275,56	65 x 18	145,43											
M 33x2,00	2	31,00	100 x 25 x 20,0	370,90	65 x 18	145,43											
M 33x3,00	2	30,00	125 x 56 x 20,0	429,96*	65 x 25	133,40*											

FILIERE CON MISURA ESTERNA IN POLLICI

		C5			
Ø x L3 mm	€	Ø x L3 mm	€		
M 3x0,50	25,4 x 9,5	23,63	M 8x1,25	38,1 x 12,7	32,14
M 4x0,70	25,4 x 9,5	23,63	M 10x1,50	25,4 x 9,50	29,70
M 5x0,80	25,4 x 9,5	23,45	M 10x1,50	38,1 x 12,7	39,86
M 6x1,00	25,4 x 9,5	23,63	M 12x1,75	25,4 x 9,50	29,42
M 8x1,25	25,4 x 9,5	23,66	M 12x1,75	38,1 x 12,7	40,20

* Consultare il prezzo delle serie di maschi e filiere a sinistra disponibili a Pag.188
* Sovrapprezzo per le filiere regolabili pari al 20% del prezzo.

SERIE DI MASCHI E FILIERE PER FILETTARE A MANO HSS

Maschi e Filiere

Verde

UNC

Ref. M0

HSS	DIN 351	TOL 2B
HSS	DIN 223	TOL 2a

Ref. C5

UNF

Ref. M0

HSS	DIN 2181	TOL 2B
HSS	DIN 223	TOL 2a

Ref. C5



	U.tà	D1 mm		M0		C5	
				L1 x L2 x mm	€	Ø x L3 mm	€
UNC n°1-64h.	3	1,85	1,50	36x8x2,1	116,08	16x5	
UNC n°2-56h.	3	2,18	1,80	36x9x2,1	82,03	16x5	
UNC n°3-48h.	3	2,51	2,10	40x9x2,1	82,03	16x5	
UNC n°4-40h.	3	2,84	2,25	40x11x2,7	60,29	20x5	38,91
UNC n°5-40h.	3	3,17	2,60	40x11x2,7	60,52	20x5	38,91
UNC n°6-32h.	3	3,50	2,75	45x13x3,0	60,52	20x7	38,91
UNC n°8-32h.	3	4,17	3,50	45x13x3,4	60,52	20x7	38,91
UNC n°10-24h.	3	4,83	3,90	50x16x4,9	60,52	20x7	38,91
UNC n°12-24h.	3	5,49	4,50	50x19x4,9	60,52	20x7	38,91
UNC 1/4-20h.	3	6,35	5,10	50x19x4,9	32,60*	20x7	32,52*
UNC 5/16-18h.	3	7,94	6,60	56x22x4,9	35,89*	25x9	36,01*
UNC 3/8-16h.	3	9,52	8,00	70x24x5,5	40,19*	30x11	38,00*
UNC 7/16-14h.	3	11,11	9,40	70x24x6,2	49,84	38x14	43,81
UNC 1/2-13h.	3	12,70	10,75	75x29x7,0	66,92*	38x14	48,77*
UNC 9/16-12h.	3	14,28	12,20	80x30x9,0	78,99	38x14	53,85
UNC 5/8-11h.	3	15,87	13,50	80x32x9,0	89,50*	45x18	53,66*
UNC 3/4-10h.	3	19,05	16,50	95x40x11,0	118,75*	45x18	62,97*
UNC 7/8-9h.	3	22,22	19,50	100x40x14,5	146,19	55x22	93,42
UNC 1"-8h.	3	25,40	22,25	110x50x14,5	176,26*	55x22	93,42*
UNC 1.1/8-7h.	3	28,57	25,00	125x56x18,0	361,43	65x25	151,42
UNC 1.1/4-7h.	3	31,75	28,00	125x56x18,0	428,17	65x25	151,42
UNC 1.3/8-6h.	3	34,92	30,75	150x63x22,0	661,99	65x25	151,42
UNC 1.1/2-6h.	3	38,10	34,00	150x63x24,0	646,08	75x30	151,43
UNC 2"-4,5h.	3	50,80	45,00	180x75x32,0	1.324,27	90x36	

	U.tà	D1 mm		M0		C5	
				L1 x L2 x mm	€	Ø x L3 mm	€
UNF n°2-64h.	2	2,18	1,85	36x8x2,1	72,14		
UNF n°3-56h.	2	2,51	2,15	40x9x2,1	61,34		
UNF n°4-48h.	2	2,84	2,35	40x9x2,7	36,87	20x5	38,91
UNF n°5-44h.	2	3,17	2,70	45x10x2,7	36,87	20x5	38,91
UNF n°6-40h.	2	3,50	2,95	45x16x3,0	36,51	20x5	38,91
UNF n°8-36h.	2	4,17	3,50	50x12x3,4	36,51	20x7	38,91
UNF n°10-32h.	2	4,83	4,10	50x12x4,9	36,51	20x7	38,91
UNF n°12-28h.	2	5,49	4,60	50x12x4,9	36,41	20x7	38,91
UNF 1/4-28h.	2	6,35	5,50	50x14x4,9	22,30*	25x9	32,52*
UNF 5/16-24h.	2	7,94	6,90	56x22x4,9	22,11*	25x9	36,03*
UNF 3/8-24h.	2	9,52	8,50	63x20x5,5	32,02*	38x10	37,40*
UNF 7/16-20h.	2	11,11	9,90	63x20x6,2	37,12	38x10	43,82
UNF 1/2-20h.	2	12,70	11,50	70x22x7,0	39,62*	38x10	48,77*
UNF 9/16-18h.	2	14,29	12,90	70x22x9,0	48,77	38x10	52,64
UNF 5/8-18h.	2	15,87	14,50	70x22x9,0	55,57*	45x14	53,66*
UNF 3/4-16h.	2	19,05	17,50	80x22x11,0	72,16*	45x14	62,97*
UNF 7/8-14h.	2	22,22	20,40	80x22x14,5	95,94*	55x16	93,42*
UNF 1"-12h.	2	25,40	23,25	90x22x16,0	142,07	55x16	93,42
UNF 1"-14h.	2	25,40	23,60	90x22x14,5	160,58*	55x16	121,88*
UNF 1.1/8-12h.	2	28,57	26,50	90x22x18,0	171,33	65x18	151,43
UNF 1.1/4-12h.	2	31,75	29,50	90x22x20,0	326,28	65x18	151,42
UNF 1.3/8-12h.	2	34,92	32,80	125x35x22,0	247,50	65x18	151,42
UNF 1.1/2-12h.	2	38,10	36,00	125x40x22,0	410,37	75x20	237,88
UNF 2"-12h.	2	50,80	48,38	140x40x29,0	1.289,47	90x22	

* Consultare il prezzo delle serie di maschi e filiere a sinistra disponibili a Pag.188

SERIE DI MASCHI E FILIERE PER FILETTARE A MANO HSS

BSP (GAS) Ref. MO **DIN 5157 TOL ISO 228** Ref. C5 **DIN 5158** Ref. MOT Ref. MOX **DIN 5157 TOL 6H** Ref. C5T Ref. C5X **DIN 5158 TOL 6g**



Maschi e Filiere
Verde Rosa

U.ità	D1 mm	Ø	L1 x L2 x L3 mm	MO		C5		U.ità	D1 mm	Ø	L1 x L2 x L3 mm	MOT		C5T		MOX		C5X	
				HSS	€	HSS	€					HSS	€	TiN	€	HSS	€	HSSCo	OX
G 1/8-28h.	2	9,73	8,80	63 x 20 x 5,5	33,49*	38 x 10	45,28*	G 1/8-28 h.	2	71,43	70,01	82,05	54,39						
G 1/4-19h.	2	13,16	11,80	70 x 22 x 9,0	35,76*	38 x 10	42,43*	G 1/4-19 h.	2	96,73	75,55	109,78	56,89						
G 3/8-19h.	2	16,66	15,25	70 x 22 x 9,0	52,39*	45 x 14	57,45*	G 3/8-19 h.	2	139,15	81,50	160,79	69,36						
G 1/2-14h.	2	20,95	19,00	80 x 22 x 12,0	82,26*	45 x 14	57,45*	G 1/2-14 h.	2	233,36	92,26	258,15	73,86						
G 5/8-14h.	2	22,91	21,00	80 x 22 x 14,5	97,69*	55 x 16	91,12*												
G 3/4-14h.	2	26,44	24,50	90 x 22 x 16,0	120,14*	55 x 16	91,11*	G 3/4-14 h.	2	270,33	150,30	327,17	110,24						
G 7/8-14h.	2	30,20	28,25	90 x 22 x 18,0	192,96	65 x 18	117,18												
G 1"-11h.	2	33,25	30,75	100 x 25 x 20,0	180,07*	65 x 18	117,17*	G 1" -11 h.	2	425,73	200,77	486,25	142,68						
G 1.1/8-11h.	2	37,90	35,50	125 x 40 x 22,0	362,65	75 x 20	181,01												
G 1.1/4-11h.	2	41,91	39,50	125 x 40 x 24,0	289,67*	75 x 20	181,02*												
G 1.3/8-11h.	2	44,32	42,00	125 x 40 x 29,0	480,54	90 x 22	269,32												
G 1.1/2-11h.	2	47,80	45,25	140 x 40 x 29,0	425,94	90 x 22	269,32												
G 1.3/4-11h.	2	53,75	51,25	140 x 40 x 32,0	775,43	105 x 22	280,06												
G 2"-11h.	2	59,61	57,00	160 x 40 x 35,0	693,98	105 x 22	300,75												
G 2.1/4-11h.	2	65,71	63,00	160 x 40 x 39,0	1.632,73	105 x 22													
G 2.1/2-11h.	2	75,18	72,50	160 x 40 x 39,0	1.931,99	120 x 22													
G 2.3/4-11h.	2	81,53	79,00	160 x 40 x 39,0	2.817,62	120 x 22													
G 3"-11h.	2	87,88	85,50	160 x 40 x 39,0	2.932,55	150 x 25													
G 4"-11h.	2	113,03	110,50	180 x 45 x 44,0	4.447,69	180 x 25													

UNF 3B Ref. MO **HSS DIN 2181 TOL 3B**

U.ità	D1 mm	Ø	L1 x L2 x L3 mm	MO-3B	€
UNF n°4-48-3B	2	2,84	2,35	40x9x2,7	57,26
UNF n°5-44-3B	2	3,17	2,70	45x10x2,7	57,26
UNF n°6-40-3B	2	3,50	2,95	45x16x3,0	54,53
UNF n°8-36-3B	2	4,17	3,50	50x12x3,4	54,53
UNF n°10-32-3B	2	4,83	4,10	50x12x4,9	54,53
UNF n°12-28-3B	2	5,49	4,60	50x12x4,9	57,26
UNF 1/4-28-3B	2	6,35	5,50	50x14x4,9	41,77
UNF 5/16-24-3B	2	7,94	6,90	56x22x4,9	44,71
UNF 3/8-24-3B	2	9,52	8,50	63x20x5,5	51,62
UNF 7/16-20-3B	2	11,11	9,90	63x20x6,2	68,52
UNF 1/2-20-3B	2	12,70	11,50	70x22x7,0	70,09

* Consultare il prezzo delle serie di maschi e filiere a sinistra disponibili a Pag.188

SERIE DI MASCHI E FILIERE PER FILETTARE A MANO HSS

Maschi e Filiera

Rosa
Verde

BSW

Ref. M0

HSS

DIN
351

TOL
Classe 2

BSW

Ref. C5

HSS

DIN
223

BSF

Ref. M0

HSS

DIN
5157

TOL
ISO 228

BSF

Ref. C5

HSS

DIN
223

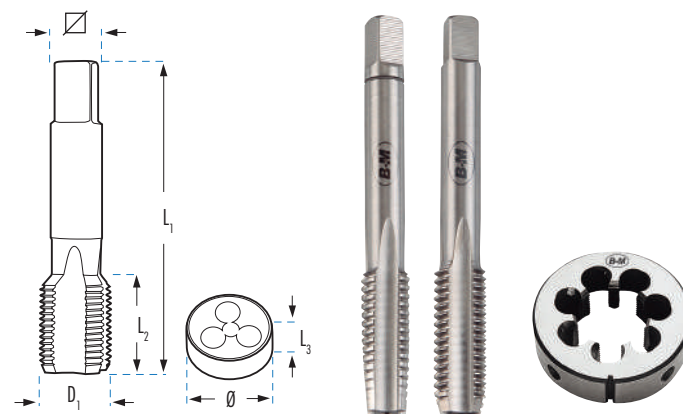

Urtà	D1 mm	Ø	L1 x L2 x mm	M0		C5	
				€	Ø x L3 mm	€	
W 1/16-60h.	3	1,59	1,15	32x8x2,1	41,49	16x5	83,35
W 3/32-48h.	3	2,38	1,80	40x9x2,1	45,28	20x5	32,23
W 1/8-40h.	3	3,17	2,55	40x14x2,7	32,53*	25x9	32,52*
W 5/32-32h.	3	3,97	3,10	45x17x3,4	30,89	25x9	32,52
W 3/16-24h.	3	4,76	3,60	50x19x4,9	30,90	25x9	32,52
W 7/32-24h.	3	5,55	4,40	50x19x4,9	30,50	25x9	32,53
W 1/4-20h.	3	6,35	5,10	50x20x4,9	30,78*	25x9	32,52*
W 5/16-18h.	3	7,94	6,50	56x20x4,9	35,80*	25x9	36,03*
W 3/8-16h.	3	9,52	7,90	63x22x5,5	44,25*	38x10	38,91*
W 7/16-14h.	3	11,11	9,25	70x22x6,2	47,51	38x10	43,81
W 1/2-12h.	3	12,70	10,50	75x25x7,0	70,11	38x14	48,78
W 9/16-12h.	3	14,29	12,00	80x26x9,0	74,19	38x14	58,05
W 5/8-11h.	3	15,87	13,40	80x27x9,0	85,31*	45x18	58,93*
W 11/16-11h.	3	17,46	15,25	95x32x11,0	251,42	45x18	59,16
W 3/4-10h.	3	19,05	16,50	95x32x11,0	113,55*	45x18	62,99*
W 7/8-9h.	3	22,22	19,25	100x32x14,5	140,01*	55x22	93,41*
W 1" - 8h.	3	25,40	21,75	110x36x14,5	229,66*	55x22	93,41*
W 1.1/8-7h.	3	28,57	24,75	125x40x18,0	289,53	65x25	174,52
W 1.1/4-7h.	3	31,75	27,75	125x40x18,0	321,91	65x25	174,59
W 1.3/8-6h.	3	34,92	30,50	150x50x22,0	441,52	65x25	177,81
W 1.1/2-6h.	3	38,10	33,50	150x50x24,0	496,12	75x30	270,28
W 1.5/8-5h.	3	41,27	46,50	150x56x24,0	892,96	75x30	324,11
W 1.3/4-5h.	3	44,45	39,00	160x58x29,0	900,29	90x36	407,90
W 1.7/8-4,5h.	3	47,62	42,00	180x65x29,0	1.268,49	90x36	446,32
W 2" - 4,5h.	3	50,80	44,50	180x65x32,0	1.410,94	90x36	467,76
W 2.1/4-4h.	3	57,15	50,00	200x85x35,0	2.626,83	105x36	
W 2.1/2-4h.	3	63,50	56,50	220x85x39,0	3.195,59	120x36	
W 2.3/4-3,5h.	3	69,85	62,00	250x90x44,0	4.562,91	120x36	
W 3" - 3,5h.	3	76,20	68,00	250x90x44,0	5.278,79	140x36	

Urtà	D1 mm	Ø	L1 x L2 x mm	M0		C5	
				€	Ø x L3 mm	€	
BSF 3/16-32h.	2	4,76	4,0	50x19x4,9	30,60	20x7	32,52
BSF 1/4-26h.	2	6,35	5,2	50x20x4,9	30,37	20x7	32,53
BSF 5/16-22h.	2	7,94	6,6	56x20x4,9	30,49	25x9	36,03
BSF 3/8-20h.	2	9,52	8,1	63x22x5,5	42,98	30x11	41,81
BSF 7/16-18h.	2	11,11	9,5	70x22x6,2	40,73	30x11	43,82
BSF 1/2-16h.	2	12,70	11,0	75x25x7,0	57,46	38x10	59,24
BSF 9/16-16h.	2	14,29	12,5	80x26x9,0	74,32	38x10	65,01
BSF 5/8-14h.	2	15,88	14,0	80x26x9,0	71,53	45x14	86,76
BSF 3/4-12h.	2	19,05	16,5	95x33x11,0	98,41	45x14	86,76
BSF 7/8-11h.	2	22,23	19,5	100x33x14,5	112,23	55x22	108,52
BSF 1" - 10h.	2	25,40	22,5	110x40x14,5	150,20	55x22	108,52
BSF 1.1/8-9h.	2	28,57	25,5	110x40x16,0	578,66		
BSF 1.1/4-9h.	2	31,75	28,5	125x46x18,0	660,65		
BSF 1.1/2-8h.	2	38,10	34,5	150x55x22,0	1.006,87		



BSW

INOX

TiN





Urtà	L1 x L2 x mm	M0T		C5T	
		€	Ø x L3 mm	€	
W 3/16-24 h.	3 50 x 19 x 4,90	58,69	25x9	46,33	
W 1/4-20 h.	3 50 x 20 x 4,90	58,08	25x9	47,78	
W 5/16-18 h	3 56 x 20 x 4,90	60,61	25x9	54,24	
W 3/8-16 h.	3 63 x 22 x 5,50	80,26	38x10	48,69	
W 1/2-12 h.	3 75 x 25 x 7,00	124,57	38x14	84,08	

* Consultare il prezzo delle serie di maschi e filiere a sinistra disponibili a Pag.188

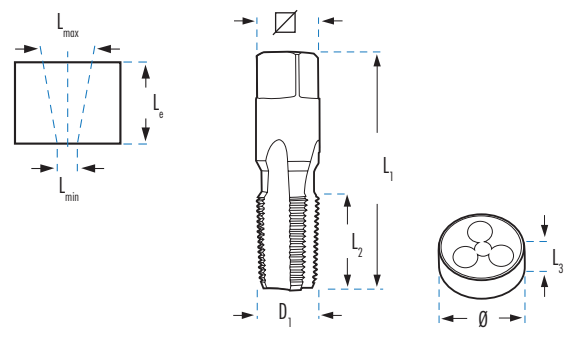
MASCHI E FILIERE PER FILETTARE A MANO HSS





NPTF  Filettatura AMERICANA
Filettatura conica a tenuta stagna Ref. M0 **HSS** Ref. C5 **HSS** **DIN 223**

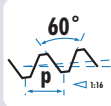

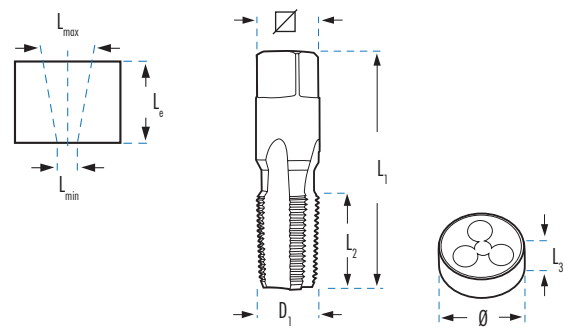
		U.ità	D1 mm			L min x L max mm	L _e mm	L1 x L2 x ∇ mm	€	Ø x L3 mm	€
NPTF 1/8-27 h.	1	10,22	8,5	8,30 x 8,76	12,0	54 x 19 x 8,0	90,54	38 x 10	197,73		
NPTF 1/4-18 h.	1	13,58	11,0	10,70 x 11,40	17,5	62 x 27 x 11,0	126,90	38 x 15	197,73		
NPTF 3/8-18 h.	1	17,02	14,5	14,20 x 14,84	17,6	65 x 27 x 13,0	175,19	45 x 14	258,19		
NPTF 1/2-14 h.	1	21,21	17,8	17,40 x 18,33	22,8	80 x 35 x 13,0	244,98	45 x 20	258,19		
NPTF 3/4-14 h.	1	26,56	23,0	22,80 x 23,68	23,0	83 x 35 x 17,0	374,47	55 x 22	492,06		
NPTF 1"-11,5 h.	1	33,19	29,0	28,60 x 29,72	27,4	110 x 38 x 20,0	498,78				

NPT  Filettatura AMERICANA
Filettatura conica non a tenuta stagna (Briggs) Ref. M0 **HSS** Ref. C5 **HSS** **DIN 223**





		U.ità	D1 mm			L min x L max mm	L _e mm	L1 x L2 x ∇ mm	€	Ø x L3 mm	€
NPT 1/16-27 h.	1	7,89	6,20	EMNPT1/16	6,00 x 6,38	12,0	54 x 18 x 6,0	37,89	25 x 9	82,00	
NPT 1/8-18 h.	1	10,24	8,50	EMNPT1/8	8,30 x 8,73	12,0	65 x 19 x 5,5	39,79	30 x 11	88,04	
NPT 1/4-18 h.	1	13,62	11,00	EMNPT1/4	10,70 x 11,35	17,5	62 x 27 x 11,0	55,83	38 x 14	104,41	
NPT 3/8-18 h.	1	17,05	14,50	EMNPT3/8	14,20 x 14,80	17,6	65 x 27 x 13,0	77,03	45 x 18	130,26	
NPT 1/2-14 h.	1	21,23	17,80	EMNPT1/2	17,40 x 18,32	22,8	80 x 35 x 13,0	107,71	45 x 18	135,47	
NPT 3/4-14 h.	1	26,57	23,00	-	22,80 x 23,66	23,0	83 x 35 x 17,0	164,68	55 x 22	204,93	
NPT 1"-11,5 h.	1	33,23	29,00	-	28,60 x 29,69	27,4	95 x 44 x 21,0	183,40	65 x 25	296,84	
NPT 1.1/4-11,5 h.	1	41,98	37,50	-	37,40 x 38,45	28,1	125 x 33 x 24,0	300,69	75 x 26	346,98	
NPT 1.1/2-11,5 h.	1	48,05	44,00	-	43,40 x 44,52	28,4	140 x 33 x 29,0	456,91	90 x 27	484,07	
NPT 2"-11,5 h.	1	60,09	56,00	-	55,50 x 56,56	28,4	160 x 33 x 35,0	713,32	105 x 36	673,96	
NPT 2.1/2"-8h.	1	73,03	67,00	-	68,68 x 69,08	28,9	200 x 45 x 39,0	879,98			
NPT 3"-8h.	1	88,90	82,00	-	84,45 x 84,86	30,5	220 x 48 x 39,0	1.236,91			

* Vedi alesatore precedente a pag. 137

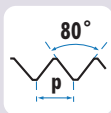
MASCHI E FILIERE PER FILETTARE A MANO HSS

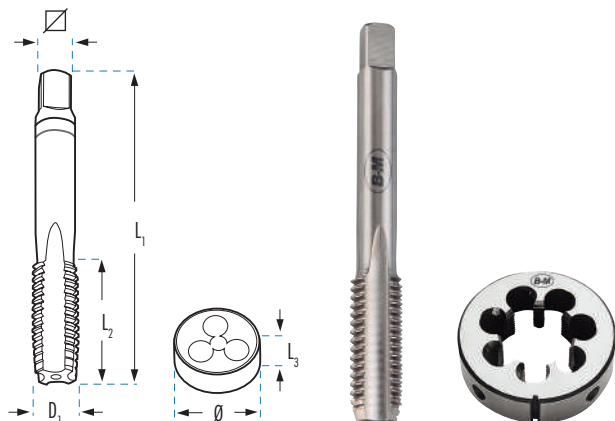

PG  Ref. MO **HSS** **DIN 40430** Ref. C5 **HSS** **DIN 223**

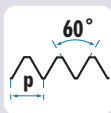

	Uità	D1 mm		L1 x L2 x mm	MO		C5	
					€	Ø x L3 mm	€	
Pg 7	20h.	12,5	11,50	70x20x7,0	40,54	38x10	75,01	
Pg 9	18h.	15,2	14,00	70x20x9,0	51,54	38x10	91,35	
Pg 11	18h.	18,6	17,25	80x22x11,0	71,55	45x14	91,36	
Pg 13,5	18h.	20,4	19,00	80x22x12,0	78,48	45x14	91,36	
Pg 16	18h.	22,5	21,25	80x22x14,5	94,25	55x16	105,45	
Pg 21	16h.	28,3	27,00	90x22x18,0	138,60	65x18	159,01	
Pg 29	16h.	37,0	35,50	100x25x22,0	275,20	65x18	159,01	
Pg 36	16h.	47,0	45,50	140x32x29,0	404,41	90x22	452,96	
Pg 42	16h.	54,0	52,50	140x36x32,0	480,25	105x22	452,96	
Pg 48	16h.	59,3	58,00	160x36x35,0	605,70	105x22	600,65	

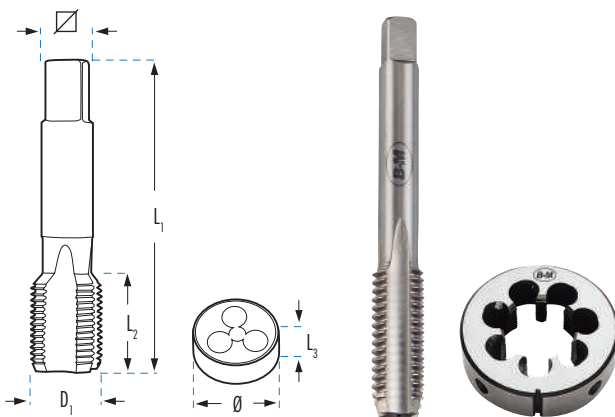

NPSF  Filettatura AMERICANA
Filettatura cilindrica a tenuta stagna Ref. MO **HSS** Ref. C5 **HSS** **DIN 223**

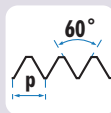

	Uità	D1 mm		L1 x L2 x mm	MO		C5	
					€	Ø x L3 mm	€	
NPSF 1/8-27 h.	1	10,05	8,75	63x18x5,5	138,94	38x10	242,07	
NPSF 1/4-18 h.	1	13,35	11,30	70x20x9,0	200,77	38x10	242,07	
NPSF 3/8-18 h.	1	16,78	14,70	70x20x9,0	277,71	45x14	307,93	
NPSF 1/2-14 h.	1	20,87	18,20	80x22x12,0	363,06	45x14	307,93	
NPSF 3/4-14 h.	1	26,23	23,50	90x22x16,0	552,42	55x16	665,61	

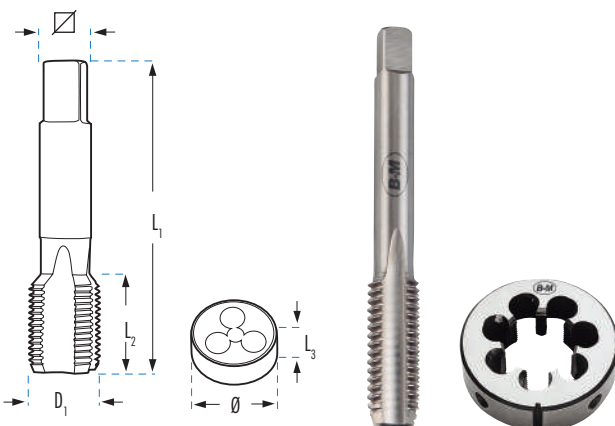
NPS (M)  Filettatura AMERICANA
Filettatura cilindrica non a tenuta stagna (Briggs) Ref. MO **HSS** Ref. C5 **HSS** **DIN 223**



	Uità	D1 mm		L1 x L2 x mm	MO		C5	
					€	Ø x L3 mm	€	
NPS 1/8-27 h.	1	10,20	8,9	63x18x5,5	115,13	38x10	201,65	
NPS 1/4-18 h.	1	13,60	11,7	70x20x9,0	91,63	38x10	201,65	
NPS 3/8-18 h.	1	17,00	15,0	70x20x9,0	126,72	45x14	256,59	
NPS 1/2-14 h.	1	21,20	18,6	80x22x12,0	165,62	45x14	256,59	
NPS 3/4-14 h.	1	26,55	24,0	90x22x16,0	240,55	55x16	508,31	
NPS 1"-11,5 h.	1	33,20	30,0	100x25x20,0	336,34	65x18	472,17	

SERIE DI MASCHI E FILIERE PER FILETTARE A MANO HSS

BSPT

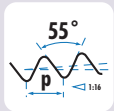

Ref. MO

HSS





DIN 5157

Ref. C5

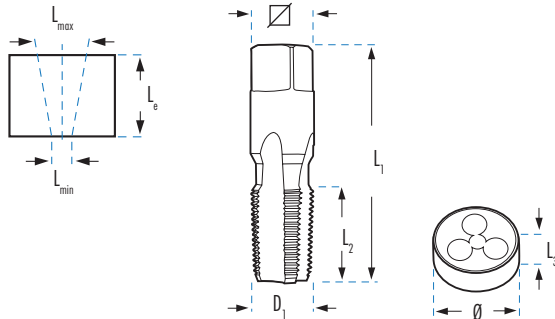
HSS

DIN 223



 	U.ità	D1 mm	 Ø	L min x L max mm	L _e mm	L1 x L2 x 	MO	C5	
							€	Ø x L3 mm	€
BSPT 1/8-28 h.	1	9,73	8,30	8,00 x 8,50	10,1	65 x 19 x 5,5	40,64	30 x 11	54,03
BSPT 1/4-19 h.	1	13,16	11,00	10,70 x 11,35	15,0	70 x 25 x 9,0	49,55	38 x 14	56,36
BSPT 3/8-19 h.	1	16,66	14,50	14,15 x 14,25	15,4	70 x 25 x 9,0	68,83	45 x 16	98,51
BSPT 1/2-14 h.	1	20,95	18,10	17,60 x 18,50	20,5	80 x 31 x 12,0	96,38	55 x 22	98,51
BSPT 5/8-14 h.	1	22,91	20,00	19,50 x 20,40	22,4	80 x 36 x 14,5	179,70	55 x 19	187,14
BSPT 3/4-14 h.	1	26,44	23,50	23,00 x 24,00	21,8	85 x 33 x 16,0	160,77	55 x 22	212,41
BSPT 7/8-14 h.	1	30,20	27,25	26,65 x 28,75	24,0	100 x 36 x 18,0	344,40	65 x 22	265,75
BSPT 1"-11 h.	1	33,25	29,60	29,00 x 30,20	26,0	110 x 38 x 20,0	229,69	65 x 25	234,61

BA

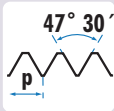

Ref. MO

HSS





DIN 352

Ref. C5

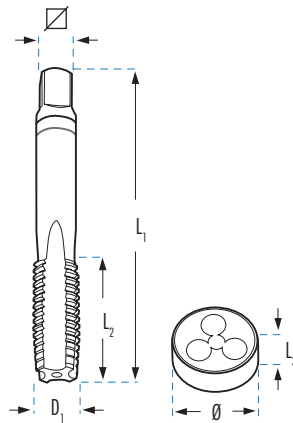
HSS

DIN 223

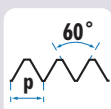

 	U.ità	D1 mm	 Ø	L1 x L2 x 	MO	C5		
					€	Ø x L3 mm	€	
BA-0	1,00	3	6,0	5,1	50 x 18 x 4,9	201,28	20 x 5	97,49
BA-1	0,90	3	5,3	4,5	50 x 18 x 4,9	201,28	20 x 5	97,49
BA-2	0,81	3	4,7	4,0	50 x 17 x 4,9	201,28	20 x 5	97,49
BA-3	0,73	3	4,1	3,4	45 x 14 x 3,4	216,32	20 x 5	97,49
BA-4	0,66	3	3,6	3,0	45 x 14 x 3,0	216,32	20 x 5	97,49
BA-5	0,59	3	3,2	2,6	45 x 14 x 3,0	258,46	20 x 5	97,49
BA-6	0,53	3	2,8	2,3	40 x 12 x 2,7	258,46	20 x 5	97,49
BA-7	0,48	3	2,5	2,0	40 x 10 x 2,1	284,17	20 x 5	97,49
BA-8	0,43	3	2,2	1,8	36 x 10 x 2,1	284,17	20 x 5	97,49

SERIE DI MASCHI E FILIERE PER FILETTARE A MANO HSS
UNx8



Filettatura AMERICANA

Ref. MO

HSS
**DIN
2181**
**TOL
2B**

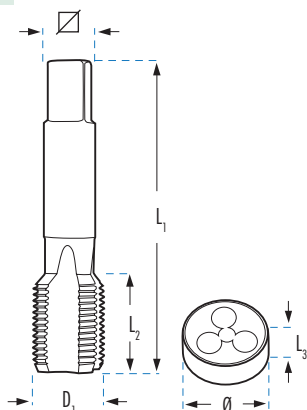
Ref. C5

HSS
**DIN
223**
**TOL
2a**

	U.iti	D1 mm		L1 x L2 x mm	MO		C5	
					€	Ø x L3 mm	€	
UN 1"1/8-8h.	2	28,57	25,40	138x65x17,0	386,94	65x25	408,27	
UN 1"1/4-8h.	2	31,75	28,50	146x65x19,5	501,80	65x25	408,27	
UN 1"3/8-8h.	2	34,92	31,75	154x76x21,0	624,11	65x25	391,28	
UN 1"1/2-8h.	2	38,10	35,00	162x76x23,5	714,23	75x30	442,96	
UN 1"5/8-8h.	2	41,27	38,10	170x80x25,0	887,99	75x30	442,96	
UN 1"3/4-8h.	2	44,45	41,25	178x81x27,0	1.106,68	90x36	516,78	
UN 1"7/8-8h.	2	47,62	44,45	186x90x29,0	1.380,64	90x36	611,44	
UN 2"-8h.	2	50,80	47,63	194x90x31,5	1.413,55	90x36	631,07	
UN 2"1/4-8h.	2	57,15	54,00	208x90x36,0				
UN 2"1/2-8h.	2	63,50	60,35	220x100x36,0				
UN 2"3/4-8h.	2	69,85	66,70	234X104X39,0				
UN 3"-8h.	2	76,20	73,05	248x115x49,0				

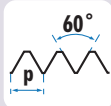
UNEF



Filettatura AMERICANA

Ref. MO

HSS
**DIN
2181**
**TOL
2B**

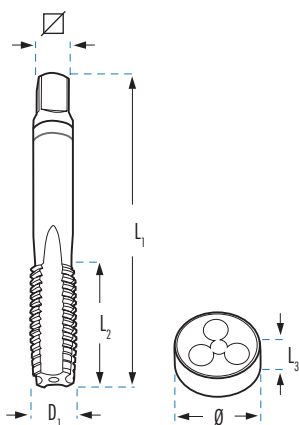
Ref. C5

HSS
**DIN
223**
**TOL
2a**

	U.iti	D1 mm		L1 x L2 x mm	MO		C5	
					€	Ø x L3 mm	€	
UNEF 1/4-32h.	2	6,35	5,55	65x28x4,9	37,82	20x7	76,37	
UNEF 5/16-32h.	2	7,94	7,15	70x30x6,0	42,25	25x9	95,42	
UNEF 3/8-32h.	2	9,52	8,70	75x33x7,0	47,49	30x11	108,10	
UNEF 7/16-28h.	2	11,11	10,20	81x38x6,0	59,39	30x11	150,16	
UNEF 1/2-28h.	2	12,70	11,80	86x44x7,0	70,77	38x10	158,81	
UNEF 9/16-24h.	2	14,29	13,20	92x44x8,0	67,88	38x10	150,16	
UNEF 5/8-24h.	2	15,87	14,80	93x47x9,0	76,47	45x14	248,79	
UNEF 3/4-20h.	2	19,05	17,80	108x52x11,0	102,13	45x14	248,79	
UNEF 7/8-20h.	2	22,22	20,95	120x58x13,0	138,56	55x16	297,08	
UNEF 1"-20h.	2	25,40	24,20	130x65x15,0	162,03	55x16	292,03	

SERIE DI MASCHI E FILIERE PER FILETTARE A MANO APPLICAZIONI SPECIALI

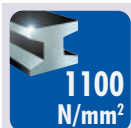

1100
N/mm²

Ref. MOMD

HSSCo
5%



DIN
352

OX

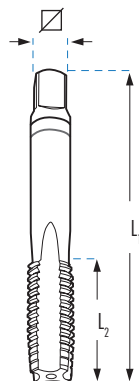

SPECIALE MATERIALI DURI
(≤ 1100 N/mm²=40Hrc)



				MOMD
	U.tà		L ₁ x L ₂ x mm	€
M 3 x 0,50	3	2,50	40 x 11 x 2,7	40,83
M 4 x 0,70	3	3,30	45 x 13 x 3,4	40,83
M 5 x 0,80	3	4,20	50 x 17 x 4,9	42,17
M 6 x 1,00	3	5,00	50 x 19 x 4,9	43,41
M 8 x 1,25	3	6,80	56 x 20 x 4,9	49,34
M 10 x 1,50	3	8,50	70 x 22 x 5,5	63,35
M 12 x 1,75	3	10,20	75 x 24 x 7,0	90,68
M 14 x 2,00	3	12,00	80 x 26 x 9,0	107,35
M 16 x 2,00	3	14,00	80 x 27 x 9,0	142,63
M 18 x 2,50	3	15,50	95 x 30 x 11,0	219,34
M 20 x 2,50	3	17,50	95 x 32 x 12,0	243,53

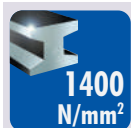

1400
N/mm²

Ref. MOC



HSS
PM

TiAlSiN

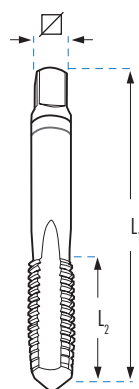

SPECIALE MATERIALI MOLTO DURI
(≤ 1400 N/mm²=44Hrc)



				MOC
	U.tà		L ₁ x L ₂ x mm	€
M 3 x 0,50	3	2,50	40 x 11 x 2,7	88,86
M 4 x 0,70	3	3,30	45 x 13 x 3,4	95,87
M 5 x 0,80	3	4,20	50 x 17 x 4,9	97,07
M 6 x 1,00	3	5,00	50 x 19 x 4,9	97,07
M 8 x 1,25	3	6,80	56 x 20 x 4,9	109,41
M 10 x 1,50	3	8,50	70 x 22 x 5,5	135,24
M 12 x 1,75	3	10,20	75 x 24 x 7,0	164,41
M 14 x 2,00	3	12,00	80 x 26 x 9,0	197,24
M 16 x 2,00	3	14,00	80 x 27 x 9,0	241,70
M 18 x 2,50	3	15,50	95 x 30 x 11,0	335,12
M 20 x 2,50	3	17,50	95 x 32 x 12,0	368,82

Al

Ref. MOAL

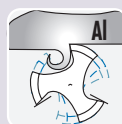

HSS

BRILLANTE

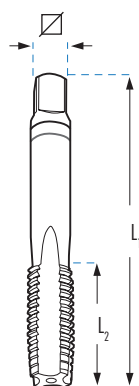

SPECIALE ALLUMINIO



				MOAL
	U.tà		L ₁ x L ₂ x mm	€
M 3 x 0,50	3	2,50	40 x 11 x 2,7	31,80
M 4 x 0,70	3	3,30	45 x 13 x 3,4	30,87
M 5 x 0,80	3	4,20	50 x 17 x 4,9	32,71
M 6 x 1,00	3	5,00	50 x 19 x 4,9	32,71
M 8 x 1,25	3	6,80	56 x 20 x 4,9	40,15
M 10 x 1,50	3	8,50	70 x 22 x 5,5	49,03
M 12 x 1,75	3	10,20	75 x 24 x 7,0	69,02
M 14 x 2,00	3	12,00	80 x 26 x 9,0	79,32
M 16 x 2,00	3	14,00	80 x 27 x 9,0	112,59
M 18 x 2,50	3	15,50	95 x 30 x 11,0	149,21
M 20 x 2,50	3	17,50	95 x 32 x 12,0	168,20

SERIE DI MASCHI E FILIERE PER FILETTARE A MANO INOX

M

INOX

Ref. MOT

DIN
352TOL
6H

TiN

Ref. CST

DIN
223TOL
6g

OX

Ref. MOX

Ref. CSX



		U.tà	L ₁ x L ₂ x ∇ mm	MOT	CST	MOX	CSX	Ø x L3 mm
				HSS	HSS	HSSCo	HSSCo	
				TiN	TiN	OX	OX	
				€	€	€	€	
M	3 x 0,50	3	40 x 11 x 2,70	29,78	26,91	34,28	29,38	20 x 5
M	4 x 0,70	3	45 x 13 x 3,40	26,07	62,56	34,28	29,38	20 x 5
M	5 x 0,80	3	50 x 16 x 4,90	28,61	28,16	34,78	28,04	20 x 7
M	6 x 1,00	3	50 x 19 x 4,90	28,61	28,16	34,70	28,01	20 x 7
M	8 x 1,00	2	50 x 19 x 4,90	30,62				
M	8 x 1,25	3	56 x 22 x 4,90	37,82	28,87	39,84	36,50	25 x 9
M	10 x 1,00	2	63 x 18 x 5,50	35,33				
M	10 x 1,50	3	70 x 24 x 5,50	44,28	36,20	53,28	48,83	30 x 11
M	12 x 1,50	2	70 x 20 x 7,00	44,97				
M	12 x 1,75	3	75 x 29 x 7,00	47,67	52,28	69,55	72,26	38 x 14
M	14 x 1,50	2	70 x 20 x 9,00	52,29				
M	14 x 2,00	3	80 x 30 x 9,00	70,18	57,89	87,71	72,26	38 x 14
M	16 x 2,00	3	80 x 32 x 9,00	76,59	73,63	107,01	104,55	45 x 18
M	18 x 2,50	3	95 x 40 x 11,00	98,92		140,15		
M	20 x 2,50	3	95 x 40 x 12,00	105,95		157,77		
M	22 x 2,50	3	100 x 40 x 14,50	134,00				
M	24 x 3,00	3	110 x 50 x 14,50	174,29				

M

FILIERE ESAGONALI HSS PER FILETTARE A MANO

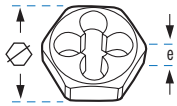

M HSS DIN 382

		C5HM	
			€
M 3 x 0,35	18 x 5	41,26	
M 3 x 0,50	19 x 5	23,24	
M 3,5 x 0,60	18 x 5	41,26	
M 4 x 0,50	18 x 5	41,26	
M 4 x 0,70	19 x 5	21,78	
M 5 x 0,50	18 x 5	41,26	
M 5 x 0,75	18 x 5	41,26	
M 5 x 0,80	19 x 7	21,78	
M 6 x 0,75	18 x 7	45,25	
M 6 x 1,00	19 x 7	23,24	
M 7 x 0,75	21 x 9	43,85	
M 7 x 1,00	21 x 9	24,63	
M 8 x 0,75	21 x 9	47,85	
M 8 x 1,00	21 x 9	47,85	
M 8 x 1,25	22 x 9	24,63	
M 9 x 0,75	21 x 9	49,63	
M 9 x 1,00	21 x 9	49,63	
M 9 x 1,25	22 x 9	44,68	
M 10 x 1,00	27 x 11	47,84	
M 10 x 1,25	27 x 11	47,84	
M 10 x 1,50	27 x 11	28,34	
M 11 x 1,00	27 x 11	74,43	
M 11 x 1,50	27 x 11	74,43	
M 12 x 1,25	36 x 10	64,01	
M 12 x 1,50	36 x 10	64,01	
M 12 x 1,75	36 x 10	41,29	
M 14 x 1,25	36 x 14	71,54	
M 14 x 1,50	36 x 10	71,54	
M 14 x 2,00	36 x 10	37,16	
M 15 x 1,00	36 x 14	98,10	
M 15 x 1,50	41 x 14	98,10	
M 16 x 1,00	41 x 14	86,60	
M 16 x 1,50	41 x 14	86,60	

		C5HM	
			€
M 16 x 2,00	41 x 18	56,08	
M 18 x 1,00	41 x 14	98,10	
M 18 x 1,50	41 x 14	91,12	
M 18 x 2,50	41 x 18	50,48	
M 20 x 1,00	41 x 14	98,10	
M 20 x 1,50	41 x 14	91,12	
M 20 x 2,00	41 x 18	98,10	
M 20 x 2,50	41 x 18	56,08	
M 22 x 1,00	50 x 16	143,32	
M 22 x 1,50	50 x 16	129,04	
M 22 x 2,00	50 x 16	143,32	
M 22 x 2,50	50 x 16	93,73	
M 24 x 1,00	50 x 16	231,28	
M 24 x 1,50	50 x 16	129,03	
M 24 x 2,00	50 x 16	129,03	
M 24 x 3,00	50 x 22	113,25	
M 27 x 1,50	60 x 18	193,78	
M 27 x 2,00	60 x 18	193,78	
M 27 x 3,00	60 x 25	166,91	
M 30 x 1,00	60 x 18	193,78	
M 30 x 1,50	60 x 18	193,78	
M 30 x 2,00	60 x 18	191,00	
M 30 x 3,00	60 x 18	193,78	
M 30 x 3,50	60 x 25	166,91	
M 33 x 1,50	60 x 18	216,98	
M 33 x 2,00	60 x 18	216,98	
M 33 x 3,50	60 x 25	186,21	
M 35 x 1,50	60 x 18	206,83	
M 36 x 1,50	60 x 18	206,83	
M 36 x 2,00	60 x 18	206,83	
M 36 x 3,00	60 x 18	206,83	
M 36 x 4,00	60 x 25	172,36	

BSW HSS DIN 382

		C5HW	
			€
BSW 1/8 x 40h.	19 x 5	47,71	
BSW 3/16 x 24h.	19 x 7	47,71	
BSW 1/4 x 20h.	19 x 7	47,71	
BSW 5/16 x 18h.	22 x 9	50,10	
BSW 3/8 x 16h.	27 x 11	59,64	
BSW 7/16 x 14h.	27 x 11	59,64	
BSW 1/2 x 12h.	36 x 14	71,59	

		C5HW	
			€
BSW 9/16 x 12h.	36 x 14	71,59	
BSW 5/8 x 11h.	41 x 18	105,80	
BSW 3/4 x 10h.	41 x 18	105,80	
BSW 7/8 x 9h.	50 x 22	155,05	
BSW 1" x 8h.	50 x 22	155,05	
BSW 1.1/8 x 7h.	60 x 25	267,26	

BSP (GAS) HSS DIN 382

		C5HG	
			€
G 1/8 x 28h.	27 x 11	84,00	
G 1/4 x 19h.	36 x 10	84,00	
G 3/8 x 19h.	41 x 14	105,03	
G 1/2 x 14h.	41 x 14	105,03	
G 5/8 x 14h.	50 x 16	247,29	
G 3/4 x 14h.	50 x 16	247,29	
G 7/8 x 14h.	60 x 18	249,51	
G 1" x 11h.	60 x 18	249,51	
G1.1/4 x 11h.	70 x 20	332,67	
G1.1/2 x 11h.	85 x 22	561,24	
G 2" x 11h.	100 x 22	844,52	

UNC HSS DIN 382

		C5HNC	
			€
UNC 1/4-20h	18 x 7	34,78	
UNC 5/16-18h	21 x 9	43,29	
UNC 3/8-16h	27 x 11	52,24	
UNC 7/16-14h	27 x 11	77,11	
UNC 1/2-13h	36 x 14	77,38	
UNC 9/16-12h	36 x 14	92,46	
UNC 5/8-11h	41 x 18	71,65	
UNC 3/4-10h	41 x 18	113,98	
UNC 7/8-9h	50 x 22	161,75	
UNC 1"-8h	50 x 22	161,75	
UNC 1.1/8-7h	60 x 25	213,85	
UNC 1.1/4-7h	60 x 25	213,85	

UNF HSS DIN 382

		C5HNF	
			€
UNF 1/4-28h.	18 x 7	36,87	
UNF 5/16-24h.	21 x 9	46,09	
UNF 3/8-24h.	27 x 11	55,44	
UNF 7/16-20h.	27 x 11	81,71	
UNF 1/2-20h.	36 x 10	82,97	
UNF 9/16-18h.	36 x 10	92,46	
UNF 5/8-18h.	41 x 14	115,37	
UNF 3/4-16h.	41 x 14	120,82	
UNF 7/8-14h.	50 x 16	152,81	
UNF 1"-12h.	50 x 16	160,21	
UNS 1"-14h.	50 x 16	160,21	
UNF 1.1/8-12h.	60 x 18	213,85	
UNF 1.1/4-12h.	60 x 18	213,85	

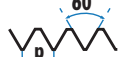
SERIE DI MASCHI E FILIERE PER FILETTARE A MANO, A SINISTRA
M
MF
DIN 13

Ref. MOI

HSS
DIN 352
DIN 2181
TOL 6H

Ref. CSI

HSS
DIN 223
TOL 6g

Per materiali fino a 38 HRc.

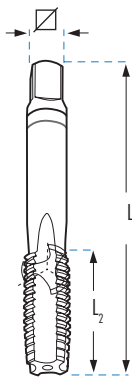

A SINISTRA

UNC

	U.tà	D1 mm		L1 x L2 x mm	MOI		CSI	
					€	Ø x L3 mm	€	
UNC 1/4-20h.	3	6,35	5,10	50x19x4,9	65,20	20x7	65,03	
UNC 5/16-18h.	3	7,94	6,60	56x22x4,9	71,77	25x9	72,02	
UNC 3/8-16h.	3	9,52	8,00	70x24x5,5	80,38	30x11	75,99	
UNC 1/2-13h.	3	12,70	10,75	75x29x7,0	133,84	38x14	97,54	
UNC 5/8-11h.	3	15,87	13,50	80x32x9,0	178,99	45x18	107,33	
UNC 3/4-10h.	3	19,05	16,50	95x40x11,0	237,50	45x18	125,95	
UNC 1"-8h.	3	25,40	22,25	110x50x14,5	352,53	55x22	186,84	

UNF

	U.tà	D1 mm		L1 x L2 x mm	MOI		CSI	
					€	Ø x L3 mm	€	
UNF 1/4-28h.	2	6,35	5,50	50x14x4,9	44,60	25x9	65,03	
UNF 5/16-24h.	2	7,94	6,90	56x22x4,9	44,23	25x9	72,06	
UNF 3/8-24h.	2	9,52	8,50	63x20x5,5	64,05	38x10	74,80	
UNF 1/2-20h.	2	12,70	11,50	70x22x7,0	79,25	38x10	97,54	
UNF 5/8-18h.	2	15,87	14,50	70x22x9,0	111,14	45x14	107,33	
UNF 3/4-16h.	2	19,05	17,50	80x22x11,0	144,32	45x14	125,95	
UNS 1"-14h.	2	25,40	23,60	90x22x14,5	321,15	55x16	243,76	

BSP (GAS)

	U.tà	D1 mm		L1 x L2 x mm	MOI		CSI	
					€	Ø x L3 mm	€	
G 1/8-28h.	2	9,73	8,80	63 x 20 x 5,5	66,97	38x10	90,56	
G 1/4-19h.	2	13,16	11,80	70 x 22 x 9,0	71,52	38x10	84,85	
G 3/8-19h.	2	16,66	15,25	70 x 22 x 9,0	104,77	45x14	114,91	
G 1/2-14h.	2	20,95	19,00	80 x 22 x 12,0	164,51	45x14	114,91	
G 5/8-14h.	2	22,91	21,00	80 x 22 x 14,5	195,37	55x16	182,25	
G 3/4-14h.	2	26,44	24,50	90 x 22 x 16,0	240,28	55x16	182,23	
G 1"-11h.	2	33,25	30,75	100 x 25 x 20,0	360,15	65x18	234,35	
G 1.1/4-11h.	2	41,91	39,50	125 x 40 x 24,0	579,33	75x20	362,05	

BSW

	U.tà	D1 mm		L1 x L2 x mm	MOI		CSI	
					€	Ø x L3 mm	€	
W 1/8-40h.	3	3,17	2,55	40x14x2,7	65,05	25x9	65,03	
W 1/4-20h.	3	6,35	5,10	50x20x4,9	61,55	25x9	65,03	
W 5/16-18h.	3	7,94	6,50	56x20x4,9	71,61	25x9	72,06	
W 3/8-16h.	3	9,52	7,90	63x22x5,5	88,50	38x10	77,83	
W 5/8-11h.	3	15,87	13,40	80x27x9,0	170,63	45x18	117,85	
W 3/4-10h.	3	19,05	16,50	95x32x11,0	227,09	45x18	125,99	
W 7/8-9h.	3	22,22	19,25	100x32x14,5	280,02	55x22	186,82	
W 1"-8h.	3	25,40	21,75	110x36x14,5	459,32	55x22	186,82	

	U.tà		L1 x L2 x mm	MOI		CSI	
				€	Ø x L3 mm	€	
M 2x0,40	3	1,60	36x9,0x2,1	59,43	16x5	61,05	
M 3x0,50	3	2,50	40x11,0x2,7	30,32	25x9	34,76	
M 4x0,70	3	3,30	45x13,0x3,4	30,30	25x9	34,76	
M 5x0,80	3	4,20	50x16,0x4,9	33,83	25x9	35,85	
M 6x1,00	3	5,00	50x19x4,9	34,20	25x9	38,60	
M 7x1,00	3	6,00	50x19x4,9	45,07	25x9	51,03	
M 8x1,00	2	7,00	56x18x4,9	42,52	25x9	55,61	
M 8x1,25	3	6,80	56x22x4,9	37,39	25x9	39,42	
M 9x1,25	3	7,80	63x22x5,5	50,74	25x9	58,23	
M 10x1,50	3	8,50	70x24x5,5	48,14	38x10	45,13	
M 12x1,50	2	10,50	70x20x7,0	75,35	38x10	76,36	
M 12x1,75	3	10,20	75x29x7,0	60,67	38x14	65,29	
M 14x1,25	2	12,80	70x20x9,0	94,95	38x10	88,26	
M 14x2,00	3	12,00	80x30x9,0	78,09	38x14	71,21	
M 16x1,50	2	14,50	70x20x9,0	100,01	45x14	104,66	
M 16x2,00	3	14,00	80x32x9,0	93,67	45x18	83,54	
M 18x2,00	2	16,00	80x22x11,0	151,16	45x14	123,67	
M 18x2,50	3	15,50	95x40x11,0	124,44	45x18	94,88	
M 20x2,00	2	18,00	80x22x12,0	194,30	45x14	120,41	
M 20x2,50	3	17,50	95x40x12,0	137,36	45x18	92,27	
M 22x2,00	2	20,00	80x22x14,5	188,51	55x16	211,72	
M 22x2,50	3	19,50	100x40x14,5	192,10	55x22	169,24	
M 24x2,00	2	22,00	90x22x14,5	256,88	55x16	215,74	
M 24x3,00	3	21,00	110x50x14,5	222,58	55x22	169,24	
M 27x2,00	2	25,00	90x22x16,0	460,14	65x18	318,85	
M 27x3,00	3	24,00	110x50x16,0	289,74	65x25	256,71	
M 30x3,00	2	27,00	125x56x18,0	487,77	65x25	226,78	
M 30x3,50	3	26,50	125x50x18,0	367,15	65x25	236,92	
M 33x2,00	2	31,00	100x25x20,0	741,81	65x18	266,81	
M 33x3,50	3	29,50	125x50x20,0	631,55	65x25	236,86	
M 36x3,00	2	33,00	125x33x22,0	855,77	65x25	282,74	
M 36x4,00	3	32,00	150x53x22,0	783,46	65x25	236,92	
M 39x3,00	2	36,00	125x33x24,0	962,99	75x30	442,95	
M 39x4,00	3	35,00	150x53x24,0	886,62	75x30	367,16	

Consultare altre misure disponibili su richiesta.

MASCHIO N°3 PER FILETTARE A MANO, FILETTO METRICO, A SINISTRA E A DESTRA

**M
MF**

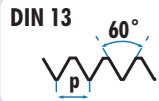

HSS

**DIN
352**

**TOL
6H**

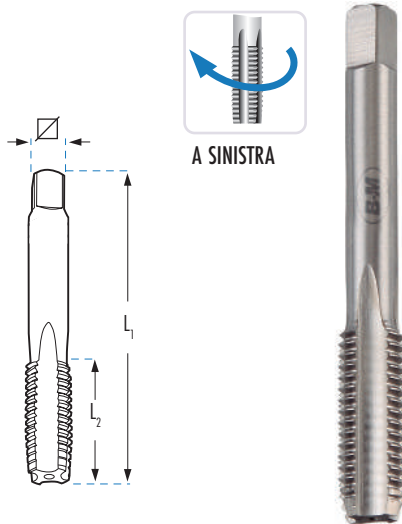

A SINISTRA

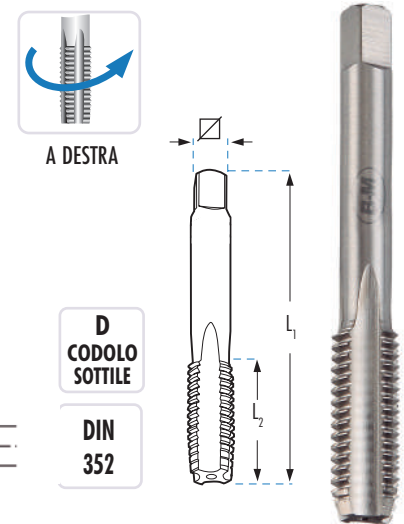

A DESTRA

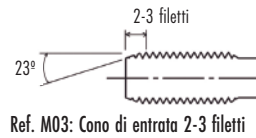

Ref. M03: Cono di entrata 2-3 filetti

**D
CODOLO
SOTTILE**
**DIN
352**

			M031
		L1 x L2 x D2 x √ mm	€
M 3x0,50	2,50	D 40 x 11 x 3,50 x 2,70	10,11
M 4x0,70	3,30	D 45 x 13 x 4,50 x 3,40	10,10
M 5x0,80	4,20	D 50 x 16 x 6,00 x 4,90	11,28
M 6x1,00	5,00	D 50 x 19 x 6,00 x 4,90	11,40
M 7x1,00	6,00	D 50 x 19 x 6,00 x 4,90	15,02
M 8x1,25	6,75	D 56 x 22 x 6,00 x 4,90	12,46
M 10x1,50	8,50	D 70 x 24 x 7,00 x 5,50	16,05
M 12x1,75	10,20	D 75 x 29 x 9,00 x 7,00	20,22
M 14x2,00	12,00	D 80 x 30 x 11,00 x 9,00	26,03
M 16x2,00	14,00	D 80 x 32 x 12,00 x 9,00	31,22
M 18x2,50	15,50	D 95 x 40 x 14,00 x 11,00	41,48
M 20x2,50	17,50	D 95 x 40 x 16,00 x 12,00	45,79

Consultare altre misure disponibili su richiesta.

			M03
		L1 x L2 x D2 x √ mm	€
M 3x0,50	2,50	D 40 x 11 x 3,50 x 2,70	5,05
M 4x0,70	3,30	D 45 x 13 x 4,50 x 3,40	5,05
M 5x0,80	4,20	D 50 x 16 x 6,00 x 4,90	5,64
M 6x1,00	5,00	D 50 x 19 x 6,00 x 4,90	5,70
M 7x1,00	6,00	D 50 x 19 x 6,00 x 4,90	7,51
M 8x1,00	7,00	D 56 x 18 x 6,00 x 4,90	10,63
M 8x1,25	6,75	D 56 x 22 x 6,00 x 4,90	6,23
M 9x1,25	7,75	D 63 x 18 x 7,00 x 5,50	8,46
M 10x1,00	9,00	D 63 x 18 x 7,00 x 5,50	12,50
M 10x1,25	8,80	D 70 x 24 x 7,00 x 5,50	11,64
M 10x1,50	8,50	D 70 x 24 x 7,00 x 5,50	8,02
M 12x1,00	11,00	D 70 x 20 x 9,00 x 7,00	20,49
M 12x1,25	10,75	D 70 x 20 x 9,00 x 7,00	20,42
M 12x1,50	10,50	D 70 x 20 x 9,00 x 7,00	18,84
M 12x1,75	10,20	D 75 x 29 x 9,00 x 7,00	10,11
M 14x1,00	13,00	D 70 x 20 x 11,00 x 9,00	31,82
M 14x1,25	12,80	D 70 x 20 x 11,00 x 9,00	23,74
M 14x1,50	12,50	D 70 x 20 x 11,00 x 9,00	20,34
M 14x2,00	12,00	D 80 x 30 x 11,00 x 9,00	13,02
M 16x1,00	15,00	D 70 x 20 x 12,00 x 9,00	34,70
M 16x1,25	14,75	D 70 x 20 x 12,00 x 9,00	34,91
M 16x1,50	14,50	D 70 x 20 x 12,00 x 9,00	25,00
M 16x2,00	14,00	D 80 x 32 x 12,00 x 9,00	15,61
M 18x1,50	16,50	D 80 x 22 x 14,00 x 11,00	25,51
M 18x2,50	15,50	D 95 x 40 x 14,00 x 11,00	20,74
M 20x1,50	18,50	D 80 x 22 x 16,00 x 12,00	27,63
M 20x2,50	17,50	D 95 x 40 x 16,00 x 12,00	22,89
M 22x2,50	19,50	D 100 x 40 x 18,00 x 14,50	32,02
M 24x3,00	21,00	D 110 x 50 x 18,00 x 14,50	37,10
M 27x3,00	24,00	D 110 x 50 x 20,00 x 16,00	48,29
M 30x3,50	26,50	D 125 x 50 x 22,00 x 18,00	61,19

CALIBRI PER IL CONTROLLO DEI PASSI DELLA FILETTATURA



	TIPI DI FILETTATURA	INTERVALLO DI PASSI		GAM
		Metrici	Inglese	€
		GAM	Passi filettatura metrica	0,25 - 2,5
GAMW	Passi filettatura metrica /filettatura inglese	0,25 - 6,0	62h - 4h	17,65

INSIEME DI GUIDE PER FILIERE M3-M12

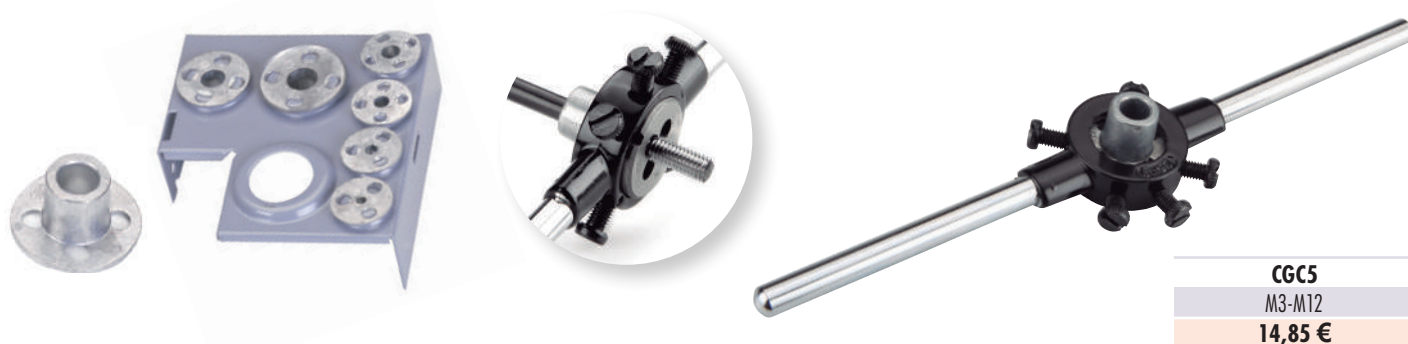

CGC5
M3-M12
14,85 €

PROLUNGA PER MASCHI

DIN
377

DIN 10

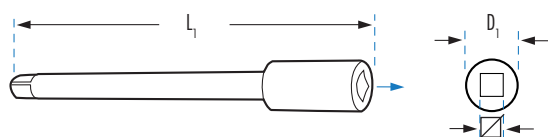

Stessa misura del attacco quadro in entrambe le zone maschio e femmina.

	∅ x L1 mm	D1 mm	AL €
AL21	2,1 x 60	6,0	8,76
AL24	2,4 x 70	6,0	8,76
AL27	2,7 x 80	7,0	8,76
AL30	3,0 x 90	7,0	8,76
AL34	3,4 x 95	8,0	9,49
AL38	3,8 x 95	9,0	9,91
AL43	4,3 x 105	10,0	11,04
AL49	4,9 x 110	11,0	10,65
AL55	5,5 x 115	12,0	10,82
AL62	6,2 x 120	14,0	13,54
AL70	7,0 x 125	15,0	14,69
AL80	8,0 x 125	17,0	18,33
AL90	9,0 x 135	19,0	18,84

	∅ x L1 mm	D1 mm	AL €
AL100	10,0 x 140	21,0	18,41
AL110	11,0 x 150	23,0	22,42
AL120	12,0 x 160	25,0	28,41
AL130	13,0 x 165	27,0	44,44
AL145	14,5 x 175	29,0	43,32
AL160	16,0 x 185	30,0	47,67
AL180	18,0 x 195	33,0	54,34
AL200	20,0 x 220	36,0	72,46
AL220	22,0 x 220	40,0	105,89
AL240	24,0 x 235	42,0	157,78
AL260	26,0 x 245	45,0	171,43
AL290	29,0 x 260	55,0	197,57
AL320	32,0 x 280	55,0	247,92

GIRAMASCHI IN ACCIAIO FORGIATO

Massima
Resistenza
150 kg/mm²

Ref. GAPRO

- Corpo in Acciaio Forgiato.
- Sopporta sforzi fino a 150 kg/mm.
- Massima resistenza e durabilità.

- Maggiore precisione e fermezza nell'attacco.
- La filettatura di precisione forma un insieme solido e robusto.
- Impugnatura antiscivolo, maggiore aderenza.



GAPRO

N° NORMA	N° 0	N° 1	N° 1.1/2	N° 2	N° 3	N° 4	N° 5
	M1-M8 2,00-5,00	M1-M10 2,00-6,30	M1-M12 2,50-7,00	M1-M12 2,50-8,00	M5-M20 4,00-13,00	M5-M27 4,00-16,00	M9-M32 5,50-20,00
€	18,25	18,54	24,63	31,12	44,05	70,42	149,05

Ref. GA

- Corpo in Lega di Zinco.
- Alta resistenza e durabilità.
- Alta precisione e fermezza nell'attacco.



GA

N° NORMA	N° 0	N° 1	N° 1.1/2	N° 2	N° 3	N° 4	N° 5	N° 7	N° 8
	M1-M8 1,50-5,00	M1-M10 2,00-7,00	M1-M12 2,00-8,00	M4-M12 2,50-10,00	M5-M20 3,50-14,00	M9-M27 4,00-15,00	M13-M32 5,50-19,00	M22-M52 14,00-34,00	M33-M64 16,00-40,00
€	10,18	12,32	16,55	20,92	29,61	47,35	100,22	206,76	425,75

GIRAFILIERE IN ACCIAIO

Ref. VA

**DIN
225**



IMPORTANTE: Al momento dell'ordine, indichi lo spessore del girafiliera in base agli spessori delle filiere indicati nella tariffa.

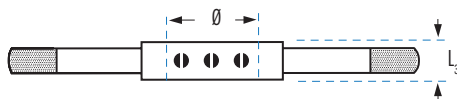

VA

Ø x L3 mm	16x5	20x5	20x7	25x9	30x11	38x10	38x14	45x14	45x18	55x16	55x22	65x18	65x25
€	10,65	11,78	11,78	13,45	16,29	21,30	21,27	26,14	26,35	33,79	35,40	48,43	48,43
Ø x L3 mm	75x20	75x30	90x22	90x36	105x22	105x36	120x22	120x36	130x25	130x36			
€	97,76	102,32	123,83	133,40	186,01	186,01	483,77	483,77	502,93	502,93			

Ref. VA

POLLICI



VA

Ø mm	20,60	25,40	38,10	50,80	63,50	76,20	88,90
POLLICI	13/16"	1"	1.1/2"	2"	2.1/2"	3"	3.1/2"
€	13,45	15,95	23,87	35,41	55,87	103,32	130,88

NOTA: I girafilieri con Ø esterno in pollici sono in disuso.

GIRAMASCHI A CRICCHETTO

Ref. TC

TIPO
T

SERIE CORTA



	CAPACITÀ mm min.-max.	Per codoli di maschi		L1 mm	PESO g	QUALITÀ	TC
		DIN	ISO				€
TC3B	2,6 - 5,5	M3 - 8	M3 - 6	85	180	1ª Qualità	29,34
TC4B	4,6 - 8,0	M5 - 12	M6 - 12	110	300	1ª Qualità	39,66
TC1B	2,6 - 5,5	M3 - 8	M3 - 6	85	180	2ª Qualità	16,82
TC2B	4,6 - 8,0	M5 - 12	M6 - 12	110	300	2ª Qualità	25,19

Ref. TL

TIPO
T

SERIE LUNGA

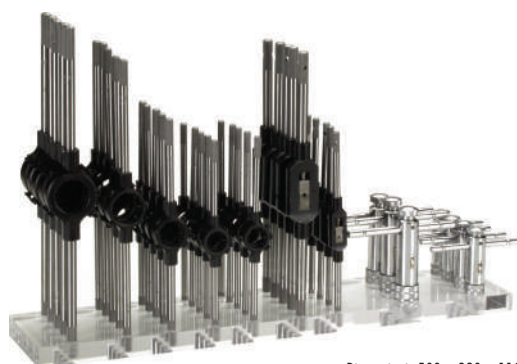

	CAPACITÀ mm min.-max.	Per codoli di maschi		L1 mm	PESO g	QUALITÀ	TL
		DIN	ISO				€
TL3	2,6 - 5,5	M3 - 8	M3 - 6	250	250	1ª Qualità	46,29
TL4	4,6 - 8,0	M5 - 12	M6 - 12	300	440	1ª Qualità	55,12
TL1	2,6 - 5,5	M3 - 10	M3 - 6	250	250	2ª Qualità	32,54
TL2	4,6 - 8,0	M5 - 12	M6 - 12	300	440	2ª Qualità	38,78

ESPOSITORE IN METACRILATO

Dimensioni: 500 x 320 x 110 mm

				GV-01
				€
GV-01	N° 1 1/2 5	N° 2 5	20 x 5 20 x 7 25 x 9 5 5 5 30 x 11 38 x 14 5 5	TC1 TC2 4 4 791,29

ASSORTIMENTO DI MASCHI E FILIERE HSS IN SCATOLA METALLICA

**M3
M12**

HSS



Ref. D624

CONTENUTO

					N° Pezzi	1° Qualità €	2° Qualità €
D624	M3 - M4 - M5 - M6 - M8 - M10 - M12	N° 1.1/2	25 x 9	-	30	258,27	234,29

ASSORTIMENTI DI FILIERE HSS IN SCATOLA METALLICA

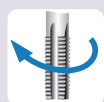

**M3
M12**

HSS



Ref. D671

CONTENUTO

			N° Pezzi	1° Qualità €	2° Qualità €		
D671	M3 - M4 - M5 - M6 - M8 - M10 - M12	20 x 5 30 x 11	20 x 7 38 x 14	25 x 9	12	254,76	215,79
D6711 (Sinistra)	M3 - M4 - M5 - M6 - M8 - M10 - M12	20 x 5 30 x 11	20 x 7 38 x 14	25 x 9	12	458,57	388,41

ASSORTIMENTI DI MASCHI E FILIERE HSS E HSSCo IN SCATOLA METALLICA CON GUIDE PER FILIERE
**M3
M12**

HSS
**HSSCo
5%**

Maschi e Filiere

Verde

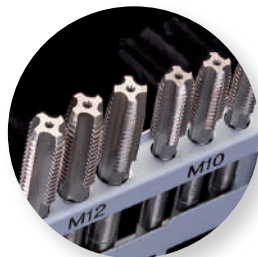





Ref. D621

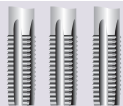

Ref. D655

CONTENUTO

						N° Pezzi	1° Qualità €	2° Qualità €
D621	M3 - M4 - M5 - M6 M8 - M10 - M12	2.5 / 3.3 / 4.2 / 5.0 6.8 / 8.5 / 10.2 mm	N° 1 N° 2	20 x 5 20 x 7 25 x 9 30 x 11 38 x 14	TC1	43	517,87	379,58
D652	M3 - M4 - M5 - M6 M8 - M10 - M12	2.5 / 3.3 / 4.2 / 5.0 6.8 / 8.5 / 10.2 mm	N° 1 N° 2	20 x 5 20 x 7 25 x 9 30 x 11 38 x 14	-	42	501,29	360,46
D662	M3-M4-M5-M6-M7 M8-M9-M10-M11-M12	-	N° 1 N° 2	20 x 5 20 x 7 25 x 9 30 x 11 38 x 14	TC1	48	771,48	678,57
D651	M3 - M4 - M5 - M6 M8 - M10 - M12	-	N° 1 N° 2	20 x 5 20 x 7 25 x 9 30 x 11 38 x 14	-	35	395,65	363,99
D655* (HSSCo)	M3 - M4 - M5 - M6 M8 - M10 - M12	2.5 / 3.3 / 4.2 / 5.0 6.8 / 8.5 / 10.2 mm	N° 1 N° 2	20 x 5 20 x 7 25 x 9 30 x 11 38 x 14	TC1	43	826,14	726,70
D6211 (Sinistra)	M3 - M4 - M5 - M6 M8 - M10 - M12	2.5 / 3.3 / 4.2 / 5.0 6.8 / 8.5 / 10.2 mm	N° 1 N° 2	20 x 5 20 x 7 25 x 9 30 x 11 38 x 14	TC1	43	932,17	683,24

*

**HSSCo
5%**

ASSORTIMENTI DI MASCHI E FILIERE HSS E HSSCo IN SCATOLA METALLICA CON GUIDE PER FILIERE

M3
M12









HSS HSSCo
5%

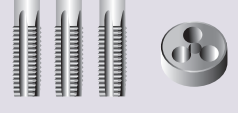

Maschi e Filiere
Verde



CONTENUTO

				 + GUIDE		N° Pezzi	1° Qualità €	2° Qualità €
D656	M3 - M4 - M5 - M6 M8 - M10 - M12	2.5 / 3.3 / 4.2 / 5.0 6.8 / 8.5 / 10.2 mm	N° 1 N° 2	20 x 5 20 x 7 25 x 9 30 x 11 38 x 14	TC1	43	578,71	512,29
D657* (HSSCo)	M3 - M4 - M5 - M6 M8 - M10 - M12	2.5 / 3.3 / 4.2 / 5.0 6.8 / 8.5 / 10.2 mm	N° 1 N° 2	20 x 5 20 x 7 25 x 9 30 x 11 38 x 14	TC1	43	861,50	760,39

* HSSCo 5%

ASSORTIMENTI DI MASCHI E FILIERE HSS E HSSCo IN SCATOLA METALLICA
**M3
M20**
**M5
M20**
HSS
**HSSCo
5%**

Ref. D622



Ref. D623

CONTENUTO

						N° Pezzi	1° Qualità €	2° Qualità €
D622	M3 - M4 - M5 - M6 - M8 - M10 - M12 M14 - M16 - M18 - M20	N° 1 N° 3	20 x 5 20 x 7 25 x 9 30 x 11 38 x 14 45 x 18	TC1 TC2	-	54	885,75	695,91
D658	M3 - M4 - M5 - M6 - M8 - M10 - M12 M14 - M16 - M18 - M20	N° 1 N° 3	20 x 5 20 x 7 25 x 9 30 x 11 38 x 14 45 x 18	-	-	52	815,98	629,61
D6221 (Sinistra)	M3 - M4 - M5 - M6 - M8 - M10 - M12 M14 - M16 - M18 - M20	N° 1 N° 3	20 x 5 20 x 7 25 x 9 30 x 11 38 x 14 45 x 18	TC1 TC2	-	54	1.594,35	1.252,64
D659* (HSSCo)	M3 - M4 - M5 - M6 - M8 - M10 - M12 M14 - M16 - M18 - M20	N° 1 N° 3	20 x 5 20 x 7 25 x 9 30 x 11 38 x 14 45 x 18	-	-	52	1.839,88	1.618,36
D623	M5 - M6 - M8 - M10 - M12 M14 - M16 - M18 - M20	N° 1 N° 3	20 x 7 25 x 9 30 x 11 38 x 14 45 x 18	TC1 TC2	-	45	928,65	727,04
D663	M5 - M6 - M7 - M8 - M9 - M10 - M12 M14 - M16 - M18 - M20	N° 1 N° 3	20 x 7 25 x 9 30 x 11 38 x 14 45 x 18	-	-	51	1.238,09	1.113,64

*

**HSSCo
5%**

ASSORTIMENTI DI MASCHI E FILIERE HSS IN SCATOLA METALLICA E DI LEGNO

M1
M10
M5
M12
M3
M24
M5
M30
HSS

Maschi e Filiere
Verde



Ref. D628



Ref. D626

CONTENUTO

					N° Pezzi	1° Qualità €	2° Qualità €
D626	M1 - M1.2 - M1.4 - M1.7 - M2.0 - M2.3 M2.6 - M3 - M3.5 - M4 - M5 - M6 - M8 - M10	N° 0 N° 1	16 x 5 20 x 5 20 x 7 25 x 9 30 x 11	TC1	64	-	1.158,45
D627	M5 - M6 - M7 - M8 - M9 - M10 - M11 - M12	N° 1 N° 2	20 x 7 25 x 9 30 x 11 38 x 14	TC1	39	-	865,42
D625	M3 - M4 - M5 - M6 - M8 - M10 - M12 - M14 M16 - M18 - M20 - M22 - M24	N° 1 N° 4	20 x 5 20 x 7 25 x 9 30 x 11 38 x 14 45 x 18 55 x 22	-	61	2.044,04	1.508,17
D628	M5 - M6 - M8 - M10 - M12 - M14 - M16 M18 - M20 - M22 - M24 - M27 - M30	N° 1 N° 3 N° 5	20 x 7 25 x 9 30 x 11 38 x 14 45 x 18 55 x 22 65 x 25	-	62	-	2.760,51





ASSORTIMENTI DI MASCHI E FILIERE HSS IN SCATOLA METALLICA
MF
HSS

Ref. D634



Ref. D636

CONTENUTO

					N° Pezzi	1ª Qualità €	2ª Qualità €
D634	MF 3 x 0.35 - 4 x 0.5 - 5 x 0.5 MF 6 x 0.75 - 8 x 0.75 - 8 x 1.0 MF 10 x 1.0 - 12 x 1.5	N° 1 N° 2	20 x 5 25 x 9 30 x 11 38 x 10	TCl	31	-	794,00
D635	MF 6 x 0.75 - 8 x 0.75 - 8 x 1.0 - 10 x 1.0 MF 12 x 1.0 - 12 x 1.5 - 14 x 1.25 - 14 x 1.5 MF 16 x 1.5 - 18 x 1.5 - 20 x 1.5	N° 1 N° 3	20 x 7 25 x 9 30 x 11 38 x 10 45 x 14	-	40	1.295,17	1.231,61
D636	MF 6 x 0.75 - 8 x 0.75 - 8 x 1.0 - 10 x 1.0 MF 12 x 1.0 - 12 x 1.5 - 14 x 1.25 - 14 x 1.5 MF 16 x 1.5 - 18 x 1.5 - 20 x 1.5 - 22 x 1.5 MF 24 x 1.5	N° 1 N° 4	20 x 7 25 x 9 30 x 11 38 x 10 45 x 14 55 x 16	-	47	1.776,74	1.642,72

ASSORTIMENTI DI MASCHI E FILIERE HSS IN SCATOLA METALLICA





**BSP
(GAS)**

HSS



Ref. D638

CONTENUTO

					N° Pezzi	1° Qualità €	2° Qualità €
D637	6 1/8 - 1/4 - 3/8 - 1/2 - 3/4 - 1"	N° 1 N° 3 N° 5	30 x 11 38 x 10 45 x 14 55 x 16 65 x 18	-	26	1.438,04	1.161,63
D638	6 1/8 - 1/4 - 3/8 - 1/2 - 5/8 - 3/4 - 7/8 - 1"	N° 1 N° 3 N° 5	30 x 11 38 x 10 45 x 14 55 x 16 65 x 18	-	32	1.951,57	1.703,58
D639	6 1/4 - 3/8 - 1/2 - 3/4 - 1" - 1".1/4 - 1".1/2	N° 2 N° 4 N° 7	38 x 10 45 x 14 55 x 16 65 x 18 75 x 20 90 x 22	-	30	3.600,32	3.037,02





BSW

HSS

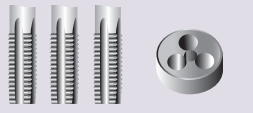

Ref. D640





CONTENUTO

					N° Pezzi	1° Qualità €	2° Qualità €
D640	BSW 1/8 - 3/16 - 1/4 - 5/16 - 3/8 - 7/16 - 1/2	N° 1 N° 2	20 x 5 20 x 7 25 x 9 30 x 11 38 x 14	TCl	36	802,23	685,78
D641	BSW 1/4 - 5/16 - 3/8 - 7/16 - 1/2	N° 1 N° 2	20 x 7 25 x 9 30 x 11 38 x 14	TCl	27	661,33	557,02
D642	BSW 1/4 - 5/16 - 3/8 - 7/16 - 1/2 - 5/8 - 3/4	N° 1 N° 3	20 x 7 25 x 9 30 x 11 38 x 14 45 x 18	-	35	1.183,54	1.079,93
D643	BSW 1/4 - 5/16 - 3/8 - 7/16 1/2 - 5/8 - 3/4 - 7/8 - 1"	N° 1 N° 4	20 x 7 25 x 9 30 x 11 38 x 14 45 x 18 55 x 22	-	44	1.673,80	1.469,54
D646	BSW 1/4 - 5/16 - 3/8 - 7/16 1/2 - 5/8 - 3/4 - 7/8 - 1" - 1".1/8 1".1/4 - 1".3/8 - 1".1/2	N° 1 N° 3 N° 5	20 x 7 25 x 9 30 x 11 38 x 14 45 x 18 55 x 22 65 x 25	-	62	-	4.465,59

ASSORTIMENTI DI MASCHI E FILIERE HSS IN SCATOLA METALLICA
BSF
HSS

Ref. D648



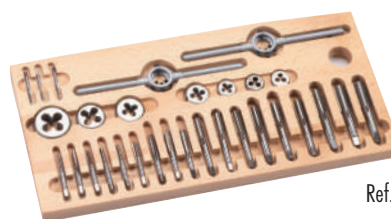

CONTENUTO

						N° Pezzi	1ª Qualità €	2ª Qualità €
D664	BSF 1/4 - 5/16 - 3/8 - 7/16 - 1/2		N° 1 N° 2	20 x 7 25 x 9 30 x 11 38 x 10	TCl	22	739,56	650,51
D648	BSF 1/4 - 5/16 - 3/8 - 7/16 - 1/2 - 5/8 - 3/4		N° 1 N° 3	20 x 7 25 x 9 30 x 11 38 x 10 45 x 14	-	28	1.148,09	1.079,93
D665	BSF 1/4 - 5/16 - 3/8 - 7/16 1/2 - 5/8 - 3/4 - 7/8 - 1"		N° 1 N° 4	20 x 7 25 x 9 30 x 11 38 x 10 45 x 14 55 x 16	-	35	1.948,12	1.713,55

**BSW
BSF**
HSS

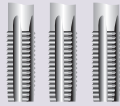
Ref. D666





CONTENUTO

						N° Pezzi	1ª Qualità €	2ª Qualità €
D666	BSW 1/4 - 5/16 - 3/8 - 7/16 - 1/2 - 5/8 - 3/4 BSF 1/4 - 5/16 - 3/8 - 7/16 - 1/2 - 5/8 - 3/4		N° 1 N° 3	20 x 7 25 x 9 30 x 11 38 x 14 45 x 18	-	63	2.200,66	1.935,68

ASSORTIMENTI DI MASCHI E FILIERE HSS IN SCATOLA METALLICA







CONTENUTO

						N° Pezzi	1° Qualità €	2° Qualità €
D660	NPT 1/8 - 1/4 - 3/8 - 1/2 - 3/4 - 1"		N°1 N°3 N°5	30 x 11 38 x 14 45 x 18 55 x 22 65 x 25	-	20	2.080,19	1.973,16
D661	NPT 1/8 - 1/4 - 3/8 - 1/2 - 3/4 1" - 1.1/4 - 1.1/2 - 2"		N° 2 N° 4 N° 7	30 x 11 38 x 14 45 x 18 55 x 22 65 x 25 75 x 30 90 x 36 105 X 36	-	29	6.227,02	5.850,26

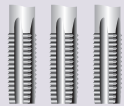



CONTENUTO

						N° Pezzi	1° Qualità €	2° Qualità €
D650	UNC 1/4 - 5/16 - 3/8 - 7/16 - 1/2		N° 1 N° 2	20 x 7 25 x 9 30 x 11 38 x 14	TCl	27	806,09	723,50
D667	UNC 1/4 - 5/16 - 3/8 - 7/16 - 1/2 - 5/8 - 3/4		N° 1 N° 2	20 x 7 25 x 9 30 x 11 38 x 14 45 x 18	-	35	1.298,75	1.142,36
D654	UNC 1/4 - 5/16 - 3/8 - 7/16 1/2 - 5/8 - 3/4 - 7/8 - 1"		N° 1 N° 4	20 x 7 25 x 9 30 x 11 38 x 14 45 x 18 55 x 22	-	44	2.095,65	1.961,26
D668	UNC 1/4 - 5/16 - 3/8 - 7/16 - 1/2 - 5/8 - 3/4 7/8 - 1" - 1.1/8 - 1.1/4 - 1.3/8 - 1.1/2"		N° 1 N° 3 N° 6	20 x 7 25 x 9 30 x 11 38 x 14 45 x 18 55 x 22 65 x 25	-	62	4.906,35	4.315,59

ASSORTIMENTI DI MASCHI E FILIERE HSS IN SCATOLA METALLICA
UNF
HSS

Ref. D644

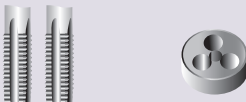

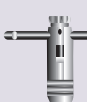

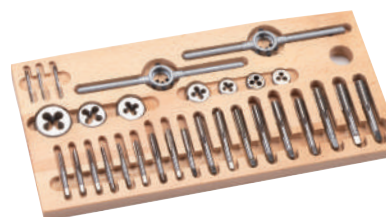
CONTENUTO

					N° Pezzi	1ª Qualità €	2ª Qualità €
D644	UNF 1/4 - 5/16 - 3/8 - 7/16 - 1/2	N° 1 N° 2	20 x 7 25 x 9 30 x 11 38 x 10	TCT	22	631,65	547,58
D669	UNF 1/4-5/16 - 3/8 - 7/16 - 1/2 - 5/8 - 3/4	N° 1 N° 3	20 x 7 25 x 9 30 x 11 38 x 10 45 x 14	-	28	1.190,50	1.047,16
D645	UNF 1/4 - 5/16 - 3/8 - 7/16 - 1/2 - 5/8 3/4 - 7/8 - 1"	N° 1 N° 4	20 x 7 25 x 9 30 x 11 38 x 10 45 x 14 55 x 16	-	34	1.459,80	1.323,60

**UNC
UNF**
HSS

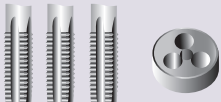
Ref. D670

CONTENUTO

					N° Pezzi	1ª Qualità €	2ª Qualità €
D670	UNC 1/4 - 5/16 - 3/8 - 7/16 - 1/2 - 5/8 - 3/4 UNF 1/4 - 5/16 - 3/8 - 7/16 - 1/2 - 5/8 - 3/4	N° 1 N° 3	20 x 7 25 x 9 30 x 11 38 x 14 45 x 18	-	35	2.200,66	1.935,68

ASSORTIMENTI DI MASCHI A MANO HSS E TIN IN SCATOLE METALLICHE



Ref. JMB0



Ref. JMB2



Ref. JMBT2

CONTENUTO

						HSS €	TiN* €
JMB2	M3 - M4 - M5 - M6 M8 - M10 - M12	-	-	-	-	171,76	JMBT2 339,25
JMB0	M3 - M4 - M5 - M6 M8 - M10 - M12	2.5 / 3.3 / 4.2 / 5.0 6.8 / 8.5 / 10.2 mm	-	-	-	195,94	JMBT0 380,71
JMB1	M3 - M4 - M5 - M6 M8 - M10 - M12	2.5 / 3.3 / 4.2 / 5.0 6.8 / 8.5 / 10.2 mm	N° 1.1/2	-	-	216,57	JMBT1 399,62
JMB5	M3 - M4 - M5 - M6 M8 - M10 - M12	2.5 / 3.3 / 4.2 / 5.0 6.8 / 8.5 / 10.2 mm	N° 1.1/2	TC1	-	233,18	JMBT5 418,75
JMBI2 (Sinistra)	M3 - M4 - M5 - M6 M8 - M10 - M12	-	-	-	-	309,17	JMBIT2 610,65
JMBI0 (Sinistra)	M3 - M4 - M5 - M6 M8 - M10 - M12	2.5 / 3.3 / 4.2 / 5.0 6.8 / 8.5 / 10.2 mm	-	-	-	352,69	JMBIT0 685,28
JMBI1 (Sinistra)	M3 - M4 - M5 - M6 M8 - M10 - M12	2.5 / 3.3 / 4.2 / 5.0 6.8 / 8.5 / 10.2 mm	N° 1.1/2	-	-	389,82	JMBIT1 719,31

ASSORTIMENTI DI MASCHI FINITORI A MANO HSS E TIN IN SCATOLE METALLICHE



Ref. JMB3



Ref. JMB4

CONTENUTO

3°						HSS €	TiN* €
JMB3	M3 - M4 - M5 - M6 M8 - M10 - M12	-	-	-	-	83,78	JMBT3 104,37
JMB4	M3 - M4 - M5 - M6 M8 - M10 - M12	2.5 / 3.3 / 4.2 / 5.0 6.8 / 8.5 / 10.2 mm	-	-	-	104,27	JMBT4 137,87
JMB7	M3 - M4 - M5 - M6 M8 - M10 - M12	2.5 / 3.3 / 4.2 / 5.0 6.8 / 8.5 / 10.2 mm	N° 1.1/2	-	-	119,33	JMBT7 191,23
JMB6	M3 - M4 - M5 - M6 M8 - M10 - M12	2.5 / 3.3 / 4.2 / 5.0 6.8 / 8.5 / 10.2 mm	N° 1.1/2	TC1	-	129,20	JMBT6 203,83
JMBI3 (Sinistra)	M3 - M4 - M5 - M6 M8 - M10 - M12	-	-	-	-	150,80	JMBIT3 187,87
JMBI4 (Sinistra)	M3 - M4 - M5 - M6 M8 - M10 - M12	2.5 / 3.3 / 4.2 / 5.0 6.8 / 8.5 / 10.2 mm	-	-	-	187,68	JMBIT4 248,16



ASSORTIMENTI DI MASCHI A MANO HSSCO IN SCATOLE METALLICHE
HSSCo
5%

Ref. JMBX0

CONTENUTO

INOX	MOX	HSSCo	N° 1.1/2		€
JMBX0	M3 - M4 - M5 - M6 M8 - M10 - M12	2.5 / 3.3 / 4.2 / 5.0 6.8 / 8.5 / 10.2 mm	-	-	303,01
JMBX1	M3 - M4 - M5 - M6 M8 - M10 - M12	2.5 / 3.3 / 4.2 / 5.0 6.8 / 8.5 / 10.2 mm	N° 1.1/2	-	318,89
JMBX2	M3 - M4 - M5 - M6 M8 - M10 - M12	-	-	-	286,53

CONTENUTO

1100 N/mm ²	MOMD	HSSCo	N° 1.1/2		€
JMBMD0	M3 - M4 - M5 - M6 M8 - M10 - M12	2.5 / 3.3 / 4.2 / 5.0 6.8 / 8.5 / 10.2 mm	-	-	316,43
JMBMD1	M3 - M4 - M5 - M6 M8 - M10 - M12	2.5 / 3.3 / 4.2 / 5.0 6.8 / 8.5 / 10.2 mm	N° 1.1/2	-	332,88
JMBMD2	M3 - M4 - M5 - M6 M8 - M10 - M12	-	-	-	301,61

SET DI FILIERE HSS IN SCATOLE METALLICHE

Ref. C5B3

CONTENUTO

	HSS	€
C5B3	M3 - M4 - M5 - M6 - M8 - M10 - M12	153,40
C5B3I (Sinistra)	M3 - M4 - M5 - M6 - M8 - M10 - M12	276,12

ESTRATTORE DI MASCHI ROTTI PER MASCHI A SCANALATURE DRITTE – NON ELICOIDALI



ESTRATTORI SCIOLTI

Ø MASCHIO DA ESTRARRE		MASCHI A MANO	MASCHI A MACCHINA	€/ U.tà
BSW UNC	M			ESTRATTORE COMPLETO
--	M3		W10043	48,19
1/8	M3,2		W10053	48,19
--	M3,5		W10063	48,19
5/32	M4		W10083	48,19
3/16	M5		W10103	48,19
--	M5,5	W10124	W10123	48,19
1/4	M6		W10253	49,62
5/16	M8	W10314	W10313	51,99
--	M9	W10374	W10373	51,49
3/8	M10	W10404	W10373	51,49
7/16	M11	W10434	W10433	54,36
1/2	M12	W10504	W10503	58,11
9/16	M14	W10564	W10563	80,33
5/8	M16	W10624	W10623	87,43
--	M18	W10684	W10753	108,33
3/4	M20	W10754	W10753	108,33
7/8	M22	W10874	W10873	118,52
1"	M25	W11004	W11003	132,18

ASTA DI RICAMBIO

MASCHI A MANO	MASCHI A MACCHINA	€/ U.tà
		ASTA EXTRA
	W12043	2,55
	W12053	2,55
	W12063	2,55
	W12083	2,55
	W12103	3,83
	W12123	3,83
	W12253	4,67
W12314	W12313	5,26
W12374		5,26
W12404	W12373	5,44
W12434	W12433	5,51
W12504	W12503	6,94
W12564	W12563	7,76
W12624	W12623	9,90
W12684		9,90
W12754	W12753	10,49
W12874	W12873	13,59
W13004	W13003	22,60

3 SEMPLICI PASSI PER L'ESTRAZIONE DI MASCHI ROTTI A SCANALATURE DRITTE

Rimuovere i trucioli del maschio rotto. Introdurre le aste dell'estrattore nelle scanalature del maschio rotto con fermezza fino in fondo.



Spingere il supporto verso il basso, fino a toccare il maschio rotto. Far scivolare la boccola verso il basso, fino a toccare la superficie di lavoro.



Applicare un giramaschi all'attacco quadro dell'estrattore. Girare a sinistra più volte fino a sbloccarlo, allora estrarre il maschio rotto.

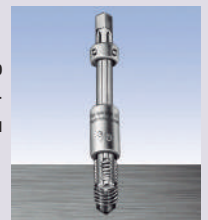

SET DI ESTRATTORI PER MASCHI ROTTI (SCANALATURE DRITTE)

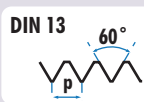
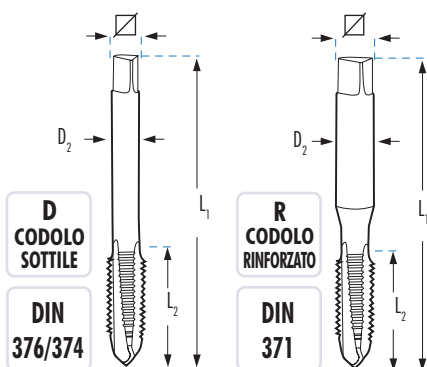

N° CANALI	MISURE INCLUSE PER MASCHI A MACCHINA E A MANO E: 3 E 4 CANALI	
W180013	3	M5- M6- M8- M10- M11- M12
W180014	4	3/16 - 1/4 - 5/16 - 3/8 - 7/16 - 1/2
W180023	3	M6- M8 -M10- M11- M12- M16
W180024	4	1/4 - 5/16 - 3/8 - 7/16 - 1/2 - 5/8
W180153	3	M3- M3,2- M3,5- M4-M5- M5,50- M6- M8
W180154	4	M9- M10- M12- M16- M18- M22- M25
		334,11
		375,91
		1.051,49

MASCHI PER FILETTARE A MACCHINA HSSCo
M
MF

HSSCo
5%
TOL
6H
Vc
12 m/min

		L1 x L2 x D2 x ∇ mm	M1D	M2D	M3D	M4D	M1R	M2R	M3R	M4R
			FORMA C €	FORMA B €	 15° €	 35° €	FORMA C €	FORMA B €	 15° €	 35° €
M 1x0,25	0,75	R 40 x 5,5 x 2,5 x 2,1					44,01			
M 1,1x0,25	0,85	R 40 x 6 x 2,5 x 2,1					42,81			
M 1,2x0,25	0,95	R 40 x 6 x 2,5 x 2,1					40,60			
M 1,4x0,30	1,10	R 40 x 7 x 2,5 x 2,1					40,60			
M 1,6x0,35	1,25	R 40 x 8 x 2,5 x 2,1					39,88			
M 1,7x0,35	1,35	R 40 x 8 x 2,5 x 2,1					38,40			
M 1,8x0,35	1,45	R 40 x 8 x 2,5 x 2,1					37,47			
M 2x0,40	1,60	R 40 x 8 x 2,8 x 2,1					18,05	19,24	22,33	21,13
M 2,2x0,45	1,75	R 40 x 9 x 2,8 x 2,1					19,49			
M 2,3x0,40	1,90	R 40 x 9 x 2,8 x 2,1					17,96			
M 2,5x0,45	2,05	R 50 x 9 x 2,8 x 2,1					18,05	19,24	30,24	21,13
M 2,6x0,45	2,10	R 50 x 9 x 2,8 x 2,1					17,41	19,58		37,84
M 3x0,50	2,50	R 56 x 11 x 3,5 x 2,7 D 56 x 11 x 2,2 x 1,8	10,55	11,50	16,39	13,84	11,95*	12,02	16,37	15,53
M 3x0,60	2,40	R 56 x 11 x 3,5 x 2,7					21,24	23,15		29,48
M 3,5x0,60	2,90	R 56 x 12 x 4,0 x 3,0 D 56 x 12 x 2,5 x 2,1					17,37	18,05	22,48	21,89
M 3,5x0,75	2,75	R 56 x 12 x 4,0 x 3,0					22,11			
M 4x0,50	3,50	R 63 x 13 x 4,5 x 3,4 D 63 x 13 x 2,8 x 2,1	22,67	25,66		27,42	25,00	26,79		31,01
M 4x0,70	3,30	R 63 x 13 x 4,5 x 3,4 D 63 x 13 x 2,8 x 2,1	10,75	11,67	16,13	13,71	13,34*	12,82	16,54	15,55
M 4x0,75	3,25	R 63 x 13 x 4,5 x 3,4					18,30	20,30		
M 4x0,80	3,20	R 63 x 13 x 4,5 x 3,4					97,18			
M 4,5x0,50	4,00	R 70 x 14 x 6,0 x 4,9						31,16		
M 4,5x0,75	3,75	R 70 x 14 x 6,0 x 4,9					23,47	25,83		
M 5x0,50	4,50	R 70 x 14 x 6,0 x 4,9 D 70 x 11 x 3,5 x 2,7	23,35	26,40		27,71	25,76	27,51		33,09
M 5x0,75	4,50	R 74 x 14 x 6,0 x 4,9 D 70 x 16 x 3,5 x 2,7					23,07	26,09		32,87
M 5x0,80	4,20	R 70 x 16 x 6,0 x 4,9 D 70 x 16 x 3,5 x 2,7	10,75	11,77	15,47	13,17	12,17*	12,90	16,71	14,91
M 5x0,90	4,10	R 70 x 15 x 6,0 x 4,9 D 70 x 16 x 3,5 x 2,7					19,35	24,92		
M 5x1,00	4,00	R 72 x 17 x 6,0 x 4,9					51,81			
M 5,5x0,90	4,60	R 80 x 17 x 6,0 x 4,9					51,81			
M 6x0,50	5,50	R 80 x 17 x 6,0 x 4,9 D 80 x 13 x 4,5 x 3,4	26,11	26,54		28,99	32,46			
M 6x0,75	5,25	R 80 x 13 x 6,0 x 4,9 D 80 x 13 x 4,5 x 3,4	18,21	21,89		24,63	21,02	24,51		29,41
M 6x1,00	5,00	R 80 x 19 x 6,0 x 4,9 D 80 x 19 x 4,5 x 3,4	12,25	12,90	17,42	14,43	13,43*	13,67	17,79	16,35

* Consultare il prezzo delle serie di maschi e filetere a sinistra disponibili a Pag.215

MASCHI PER FILETTARE A MACCHINA HSSCo











M	MF	Ø	L1 x L2 x D2 x mm	M1D	M2D	M3D	M4D	M1R	M2R	M3R	M4R
				FORMA C	FORMA B	15°	35°	FORMA C	FORMA B	15°	35°
				€	€	€	€	€	€	€	€
M 6x1,25		4,75	R 80 x 17 x 6,0 x 4,9					50,90			
M 7x0,75		6,25	D 80 x 13 x 5,5 x 4,3	23,45	26,42		28,99				
M 7x1,00		6,00	R 80 x 19 x 7,0 x 5,5 D 80 x 19 x 5,5 x 4,3	16,78	19,40	20,97	20,18	17,97 *	19,49	23,70	23,45
M 8x0,50		7,50	D 80 x 13 x 6 x 4,9	32,74							
M 8x0,75		7,25	D 80 x 13 x 6 x 4,9	22,85	27,38		28,99				
M 8x1,00		7,00	D 90 x 20 x 6 x 4,9	19,40	22,27	25,70	23,75				
M 8x1,25		6,80	R 90 x 22 x 8 x 6,2 D 90 x 22 x 6 x 4,9	13,73	14,63	19,81	17,01	15,65 *	15,66	19,45	19,11
M 8x1,50		6,50	D 90 x 20 x 6 x 4,9	92,42							
M 9x1,00		8,00	D 90 x 20 x 7 x 5,5	26,69	26,52		29,81				
M 9x1,25		7,80	R 90 x 22 x 9 x 7,0 D 90 x 22 x 7 x 5,5	22,69	24,78	28,91	29,33	24,99	22,31	32,36	27,42
M 10x0,50		9,50	D 90 x 20 x 7 x 5,5	91,57							
M 10x0,75		9,25	D 90 x 16 x 7 x 5,5	31,03	30,66		35,03				
M 10x1,00		9,00	D 90 x 16 x 7 x 5,5	21,47	24,77	30,35	30,02				
M 10x1,25		8,80	D 100 x 22 x 7 x 5,5	24,59	29,58	33,06	32,70				
M 10x1,50		8,50	R 100 x 24 x 10 x 8,0 D 100 x 24 x 7 x 5,5	15,81	17,69	23,57	20,37	17,41 *	19,28	22,40	22,64
M 11x1,00		10,00	D 90 x 20 x 8 x 6,2	35,73	38,29	96,82	45,91				
M 11x1,25		9,75	D 100 x 22 x 8 x 6,2	36,84	40,95	96,82	45,41				
M 11x1,50		9,50	D 100 x 24 x 8 x 6,2	28,77	32,78	70,60	65,44				
M 12x0,75		11,25	D 100 x 22 x 9 x 7,0	56,43							
M 12x1,00		11,00	D 100 x 22 x 9 x 7,0	29,23	32,52	37,43	37,02				
M 12x1,25		10,75	D 100 x 22 x 9 x 7,0	29,58	32,85	35,84	35,45				
M 12x1,50		10,50	D 100 x 22 x 9 x 7,0	26,44*	29,30	34,47	34,09				
M 12x1,75		10,20	D 110 x 28 x 9 x 7,0	19,07*	22,07	28,46	25,99				
M 13x0,75		12,25	D 100 x 22 x 11 x 9,0	98,47							
M 13x1,00		12,00	D 100 x 22 x 11 x 9,0	52,14	53,14						
M 13x1,25		11,75	D 100 x 22 x 11 x 9,0	52,14	59,05						
M 13x1,50		11,50	D 100 x 22 x 11 x 9,0	52,14	53,14						
M 13x1,75		11,25	D 100 x 28 x 11 x 9,0	49,86	59,05						
M 14x0,75		13,25	D 100 x 22 x 11 x 9,0	98,47							
M 14x1,00		13,00	D 100 x 22 x 11 x 9,0	42,74	49,84	57,73	55,97				
M 14x1,25		12,80	D 100 x 22 x 11 x 9,0	37,76	43,70	52,94	52,36				
M 14x1,50		12,50	D 100 x 22 x 11 x 9,0	31,50*	34,69	41,75	41,29				
M 14x2,00		12,00	D 110 x 30 x 11 x 9,0	31,28*	33,60	40,28	38,79				
M 15x1,00		14,00	D 100 x 22 x 12 x 9,0	59,82	58,40		64,71				
M 15x1,25		13,75	D 100 x 22 x 12 x 9,0	64,07	69,36						
M 15x1,50		13,50	D 100 x 22 x 12 x 9,0	51,22	58,40	143,67	64,55				
M 15x2,00		13,00	D 110 x 30 x 12 x 9,0	62,69	68,97						
M 16x1,00		15,00	D 100 x 22 x 12 x 9,0	53,17	59,16	80,80	64,50				
M 16x1,25		14,75	D 100 x 22 x 12 x 9,0	56,98	59,68	89,87	64,77				
M 16x1,50		14,50	D 100 x 22 x 12 x 9,0	37,24*	43,39	52,02	51,46				
M 16x2,00		14,00	D 110 x 32 x 12 x 9,0	36,80*	37,49	45,92	44,76				
M 17x1,00		16,00	D 100 x 22 x 12 x 9,0	112,17							
M 17x1,25		15,75	D 100 x 22 x 12 x 9,0	112,17							
M 17x1,50		15,50	D 100 x 22 x 12 x 9,0	112,17							
M 18x1,00		17,00	D 110 x 25 x 14 x 11,0	59,55	69,36		78,94				
M 18x1,25		16,75	D 110 x 25 x 14 x 11,0	78,25							
M 18x1,50		16,50	D 110 x 25 x 14 x 11,0	49,29*	54,24	63,92	62,19				
M 18x2,00		16,00	D 125 x 30 x 14 x 11,0	60,91	74,25	126,49	79,46				

* Consultare il prezzo delle serie di maschi e filiere a sinistra disponibili a Pag.215

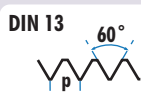
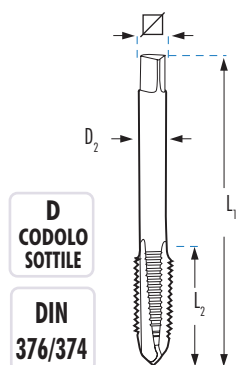
MASCHI PER FILETTARE A MACCHINA HSSCo
M
MF

HSSCo
5%
TOL
6H
D
CODOLO
SOTTILE
DIN
376/374
Vc
12 m/min

D
CODOLO
SOTTILE
DIN
376/374

		L1 x L2 x D2 x ∇ mm	M1D	M2D	M3D	M4D
			FORMA C	FORMA B	15°	35°
			€	€	€	€
M 18x2,50	15,50	D 125 x 34 x 14 x 11,0	49,96*	53,40	61,80	63,08
M 19x1,00	18,00	D 110 x 22 x 14 x 11,0	147,39			
M 19x1,25	17,75	D 110 x 25 x 14 x 11,0	145,96			
M 19x1,50	17,50	D 110 x 25 x 14 x 11,0	144,66			
M 20x1,00	19,00	D 125 x 25 x 16 x 12,0	69,03	83,30		88,87
M 20x1,25	18,75	D 125 x 25 x 16 x 12,0	66,81			
M 20x1,50	18,50	D 125 x 25 x 16 x 12,0	55,83*	61,34	71,84	71,05
M 20x2,00	18,00	D 140 x 32 x 16 x 12,0	69,03	80,45		89,43
M 20x2,50	17,50	D 140 x 34 x 16 x 12,0	56,36*	62,53	65,96	67,32
M 21x1,00	20,00	D 125 x 25 x 16 x 12,0	213,98			
M 21x1,25	19,75	D 125 x 25 x 16 x 12,0	213,98			
M 21x1,50	19,50	D 125 x 25 x 16 x 12,0	204,34			
M 22x1,00	21,00	D 125 x 25 x 18 x 14,5	86,19	99,17		107,17
M 22x1,25	20,75	D 125 x 25 x 18 x 14,5	147,39			
M 22x1,50	20,50	D 125 x 25 x 18 x 14,5	67,19	73,91	78,81	74,16
M 22x2,00	20,00	D 140 x 32 x 18 x 14,5	86,19	102,77		107,17
M 22x2,50	19,50	D 140 x 34 x 18 x 14,5	68,22*	75,02	78,21	82,05
M 23x1,00	22,00	D 125 x 25 x 18 x 14,5	208,05			
M 23x1,50	21,50	D 125 x 25 x 18 x 14,5	208,05			
M 24x1,00	23,00	D 140 x 25 x 18 x 14,5	96,04	113,90		130,29
M 24x1,25	22,75	D 140 x 25 x 18 x 14,5	213,98			
M 24x1,50	22,50	D 140 x 28 x 18 x 14,5	77,96	90,87	105,33	104,19
M 24x2,00	22,00	D 140 x 28 x 18 x 14,5	99,46*	114,87		119,39
M 24x3,00	21,00	D 160 x 38 x 18 x 14,5	81,67*	88,38	94,28	99,74
M 25x1,00	24,00	D 140 x 28 x 18 x 14,5	172,80			
M 25x1,25	23,75	D 140 x 28 x 18 x 14,5	289,42			
M 25x1,50	23,50	D 140 x 28 x 18 x 14,5	121,43	120,97		
M 25x2,00	23,00	D 140 x 28 x 18 x 14,5	276,80	287,26		
M 26x1,00	25,00	D 140 x 28 x 18 x 14,5	142,20			
M 26x1,50	24,50	D 140 x 28 x 18 x 14,5	101,62	116,81	197,33	130,14
M 26x2,00	24,00	D 140 x 28 x 18 x 14,5	119,95	121,79		126,35
M 27x1,00	26,00	D 140 x 28 x 20 x 16,0	137,25	142,21		
M 27x1,50	25,50	D 140 x 28 x 20 x 16,0	114,80	128,91	286,79	158,14
M 27x2,00	25,00	D 140 x 28 x 20 x 16,0	126,11*	150,41		

* Consultare il prezzo delle serie di maschi e filiere a sinistra disponibili a Pag.215

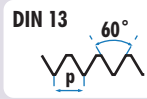
MASCHI PER FILETTARE A MACCHINA HSSCo

**M
MF**







**HSSCo
5%**

**TOL
6H**

**D
CODOLO
SOTTILE**

**DIN
376/374**

**Vc
12 m/min**



				L1 x L2 x D2 x ∇ mm	M1D	M2D	M3D	M4D
					FORMA C €	FORMA B €	 15° €	 35° €
M 27x3,00	24,00	D	160 x 36 x 20 x 16	101,96*	111,79	122,98	122,72	
M 28x1,00	27,00	D	140 x 28 x 20 x 16	276,80				
M 28x1,50	26,50	D	140 x 28 x 20 x 16	114,80	133,58	149,34	140,02	
M 28x2,00	26,00	D	140 x 28 x 20 x 16	137,76	145,23	176,01	157,76	
M 30x1,00	29,00	D	150 x 28 x 22 x 18	155,64	161,98		177,20	
M 30x1,50	28,50	D	150 x 28 x 22 x 18	119,65	139,58	161,97	160,19	
M 30x2,00	28,00	D	150 x 28 x 22 x 18	144,82*	162,92		177,62	
M 30x3,50	26,50	D	180 x 40 x 22 x 18	130,64*	143,64	157,61	157,28	
M 32x1,00	31,00	D	150 x 28 x 22 x 18	355,41	377,39			
M 32x1,50	30,50	D	150 x 28 x 22 x 18	151,42	176,21	199,53		
M 32x2,00	30,00	D	150 x 28 x 22 x 18	172,64	202,38			
M 33x1,00	32,00	D	160 x 30 x 25 x 20	339,91				
M 33x1,50	31,50	D	160 x 30 x 25 x 20	174,11	191,77		214,95	
M 33x2,00	31,00	D	160 x 30 x 25 x 20	195,70	195,21		221,49	
M 33x3,50	29,50	D	180 x 40 x 25 x 20	156,98*	180,65		200,37	
M 34x1,50	32,50	D	170 x 30 x 28 x 22	193,91	201,46			
M 34x2,00	32,00	D	160 x 30 x 28 x 22	423,51				
M 35x1,50	33,50	D	170 x 30 x 28 x 22	195,91	210,24		224,11	
M 35x2,00	33,00	D	170 x 30 x 28 x 22	376,32	414,29			
M 36x1,50	34,50	D	170 x 30 x 28 x 22	182,94	229,26		267,25	
M 36x2,00	34,00	D	170 x 30 x 28 x 22	233,37	238,99			
M 36x3,00	33,00	D	200 x 50 x 28 x 22	250,40	239,44		279,34	
M 36x4,00	32,00	D	200 x 50 x 28 x 22	187,19*	220,75	256,40	245,32	
M 38x1,50	36,50	D	170 x 30 x 28 x 22	195,03	232,93			
M 38x2,00	36,00	D	170 x 32 x 28 x 22	439,40	483,38			
M 39x1,50	37,50	D	170 x 32 x 32 x 24	324,83				
M 39x2,00	37,00	D	170 x 32 x 32 x 24	324,83				
M 39x3,00	36,00	D	200 x 47 x 32 x 24	424,23				
M 39x4,00	35,00	D	200 x 50 x 32 x 24	233,21	256,97		273,08	
M 40x1,50	38,50	D	170 x 30 x 32 x 24	255,01	290,92			
M 40x2,00	38,00	D	170 x 30 x 32 x 24	325,71				
M 40x3,00	37,00	D	200 x 47 x 32 x 24	283,86	292,10			
M 42x1,50	40,50	D	170 x 30 x 32 x 24	278,26	288,25			
M 42x2,00	40,00	D	170 x 30 x 32 x 24	372,62				
M 42x3,00	39,00	D	200 x 45 x 32 x 24	322,93	310,33			
M 42x4,50	37,50	D	200 x 56 x 32 x 24	269,90	299,18		396,63	
M 45x1,50	43,50	D	180 x 32 x 36 x 29	332,33	387,47			
M 45x2,00	43,00	D	180 x 32 x 36 x 29	431,45				
M 45x3,00	42,00	D	200 x 47 x 36 x 29	431,45				
M 45x4,50	40,50	D	220 x 58 x 36 x 29	327,58	360,32			
M 48x1,50	46,50	D	190 x 32 x 36 x 29	327,58				
M 48x2,00	46,00	D	190 x 32 x 36 x 29	540,29				
M 48x3,00	45,00	D	220 x 52 x 36 x 29	522,83				
M 48x5,00	43,00	D	250 x 65 x 36 x 29	402,84	443,09			
M 50x1,50	48,50	D	190 x 32 x 36 x 29	397,03				
M 52x1,50	50,50	D	190 x 32 x 40 x 32	387,86				
M 52x2,00	50,00	D	190 x 32 x 40 x 32	650,61				
M 52x3,00	49,00	D	225 x 50 x 40 x 32	668,66				
M 52x5,00	47,00	D	250 x 65 x 40 x 32	437,31	491,53			

* Consultare il prezzo delle serie di maschi e filiere a sinistra disponibili a Pag.215

MASCHI PER FILETTARE A MACCHINA HSSCo

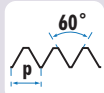
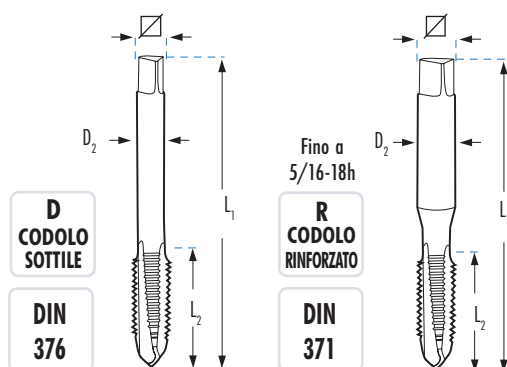
UNC

HSSCo
5%TOL
2BVc
12 m/min

	D1 mm		L1 x L2 x D2 x ∇ mm	M1R	M2R	M4R
				FORMA C	FORMA B	 35°
				€	€	€
UNC n° 4-40h	2,84	2,25	R 56 x 11 x 3,5 x 2,7	15,09	17,96	22,61
UNC n° 5-40h	3,17	2,60	R 56 x 11 x 3,5 x 2,7	15,65	18,77	22,61
UNC n° 6-32h	3,50	2,75	R 56 x 12 x 4,0 x 3,0	15,66	18,84	23,57
UNC n° 8-32h	4,17	3,50	R 63 x 13 x 4,5 x 3,4	15,66	18,84	22,54
UNC n° 10-24h	4,83	3,90	R 70 x 15 x 6,0 x 4,9	15,65	18,77	23,64
UNC n° 12-24h	5,49	4,50	R 80 x 16 x 6,0 x 4,9	16,42	18,77	22,73
UNC 1/4-20h	6,35	5,10	R 80 x 17 x 7,0 x 5,5	17,15	18,70	23,79
UNC 5/16-18h	7,94	6,60	R 90 x 20 x 8,0 x 6,2	21,40	23,59	28,67

	CODOLO SOTTILE			M1D	M2D	M4D
UNC 3/8-16h	9,52	8,00	D 100 x 22 x 7,0 x 5,5	24,10	25,24	30,29
UNC 7/16-14h	11,11	9,40	D 100 x 22 x 8,0 x 6,2	31,35	31,46	39,90
UNC 1/2-13h	12,70	10,75	D 110 x 24 x 9,0 x 7,0	28,68	31,77	39,95
UNC 9/16-12h	14,28	12,20	D 110 x 26 x 11,0 x 9,0	46,12	50,61	56,75
UNC 5/8-11h	15,87	13,50	D 110 x 27 x 12,0 x 9,0	44,77	49,30	65,06
UNC 3/4-10h	19,05	16,50	D 125 x 30 x 14,0 x 11,0	73,03	80,27	91,32
UNC 7/8-9h	22,22	19,50	D 140 x 32 x 18,0 x 14,5	96,08	105,56	137,94
UNC 1"-8h	25,40	22,25	D 160 x 36 x 18,0 x 14,5	126,95	138,69	156,16
UNC 1.1/8-7h	28,57	25,00	D 180 x 40 x 22,0 x 18,0	158,59		191,59
UNC 1.1/4-7h	31,75	28,00	D 180 x 40 x 22,0 x 18,0	185,91		245,10
UNC 1.3/8-6h	34,92	30,75	D 200 x 50 x 28,0 x 22,0	265,74		
UNC 1.1/2-6h	38,10	34,00	D 200 x 50 x 32,0 x 24,0	314,91		

MASCHI PER FILETTARE A MACCHINA HSSCo

UNF

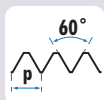



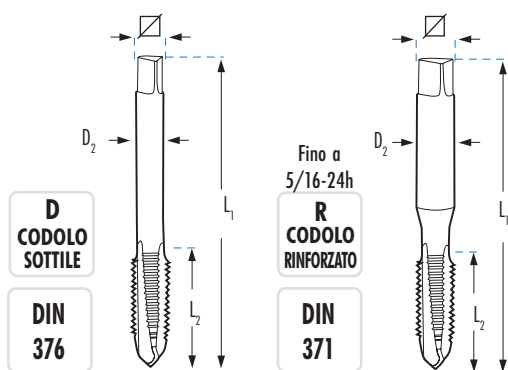

HSSCo
5%

TOL
2B

Vc
12 m/min



 	D1 mm		L1 x L2 x D2 x ∇ mm	M1R	M2R	M4R
				FORMA C	FORMA B	 35°
				€	€	€
UNF n° 4-48h	2,84	2,35	R 56 x 11 x 3,5 x 2,7	16,42	17,88	22,62
UNF n° 5-44h	3,17	2,70	R 56 x 11 x 3,5 x 2,7	16,42	17,88	22,62
UNF n° 6-40h	3,50	2,95	R 56 x 12 x 4,0 x 3,0	14,88	17,82	22,65
UNF n° 8-36h	4,17	3,50	R 63 x 13 x 4,5 x 3,4	14,88	17,82	22,65
UNF n°10-32h	4,83	4,10	R 70 x 15 x 6,0 x 4,9	14,88	17,82	22,65
UNF n°12-28h	5,49	4,60	R 80 x 16 x 6,0 x 4,9	15,00	17,97	22,62
UNF 1/4-28h	6,35	5,50	R 80 x 17 x 7,0 x 5,5	16,68	17,88	22,56
UNF 5/16-24h	7,94	6,90	R 90 x 20 x 8,0 x 6,2	19,69	22,54	27,33

	CODOLO SOTTILE			M1D	M2D	M4D
UNF 3/8-24h	9,52	8,50	D 90 x 16 x 7,0 x 5,5	21,84	25,24	31,35
UNF 7/16-20h	11,11	9,90	D 100 x 22 x 8,0 x 6,2	24,84	29,97	39,67
UNF 1/2-20h	12,70	11,50	D 100 x 22 x 9,0 x 7,0	24,99	30,09	40,04
UNF 9/16-18h	14,29	12,90	D 100 x 22 x 11,0 x 9,0	37,49	45,15	56,93
UNF 5/8-18h	15,87	14,50	D 100 x 22 x 12,0 x 9,0	37,63	45,28	63,61
UNF 3/4-16h	19,05	17,50	D 110 x 25 x 14,0 x 11,0	56,89	68,49	81,38
UNF 7/8-14h	22,22	20,40	D 125 x 25 x 18,0 x 14,5	71,53	86,14	124,46
UNF 1"-12h	25,40	23,25	D 140 x 28 x 18,0 x 14,5	87,03	109,75	136,00
UNS 1"-14h	25,40	23,60	D 140 x 28 x 18,0 x 14,5	95,93	112,85	146,49
UNF 1.1/8-12h	28,57	26,50	D 150 x 28 x 22,0 x 18,0	153,51		
UNF 1.1/4-12h	31,75	29,50	D 150 x 28 x 22,0 x 18,0	194,00		
UNF 1.1/2-12h	38,10	36,00	D 170 x 30 x 32,0 x 24,0	325,57		

MASCHI PER FILETTARE A MACCHINA HSSCo

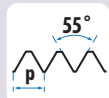
BSP
(GAS)HSSCo
5%TOL
ISO 228

INOX

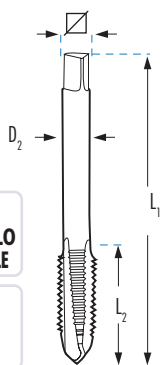
Vc
12 m/minVc
6 m/minD
CODOLO
SOTTILEDIN
5156

Icona	D1 mm	Ø	L1 x L2 x D2 x mm	M1D	M2D	M3D	M4D	M2DX	M4DX
				FORMA C	FORMA B	15°	35°	FORMA B	35°
				€	€	€	€	€	€
G 1/8-28h.	9,728	8,80	D 90 x 16 x 7 x 5,5	29,55 *	31,87	34,27	35,85	46,20	51,89
G 1/4-19h.	13,157	11,80	D 100 x 22 x 11 x 9,0	38,24 *	42,11	49,20	51,01	56,84	64,21
G 3/8-19h.	16,662	15,25	D 100 x 22 x 12 x 9,0	46,94 *	48,70	58,77	61,46	67,42	81,55
G 1/2-14h.	20,955	19,00	D 125 x 25 x 16 x 12,0	62,02 *	68,24	74,13	75,93	98,66	113,68
G 5/8-14h.	22,911	21,00	D 125 x 25 x 18 x 14,5	77,29 *	76,46	92,31	90,41		
G 3/4-14h.	26,441	24,50	D 140 x 28 x 20 x 16,0	97,07	106,85	116,04	121,35	158,82	209,13
G 7/8-14h.	30,201	28,25	D 150 x 28 x 22 x 18,0	105,01	110,45	156,06	156,06		
G 1"-11h.	33,249	30,75	D 160 x 30 x 25 x 20,0	150,69	156,35	178,16	186,34		
G 1.1/8-11h.	37,897	35,50	D 170 x 30 x 28 x 22,0	207,63	226,47		275,75		
G 1.1/4-11h.	41,910	39,50	D 170 x 30 x 32 x 24,0	256,79	270,20		291,44		
G 1.3/8-11h.	44,323	42,00	D 180 x 32 x 36 x 29,0	322,94			436,98		
G 1.1/2-11h.	47,803	45,25	D 190 x 32 x 36 x 29,0	283,49	395,17		426,36		
G 1.3/4-11h.	53,746	51,25	D 190 x 32 x 40 x 32,0	511,90	493,31				
G 2"-11h.	59,614	57,00	D 220 x 36 x 45 x 35,0	652,86	667,67				

* Disponibili anche con filettatura sinistra al doppio del prezzo.

BSF

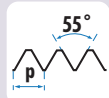
HSSCo
5%TOL
ISO 228Vc
12 m/minD
CODOLO
SOTTILEDIN
5156

Icona	D1 mm	Ø	L1 x L2 x D2 x mm	M1D
				FORMA C
				€
BSF 3/16-32h.	4,762	4,00	D 70 x 16 x 3,5 x 2,7	69,16
BSF 1/4-26h.	6,350	5,20	D 80 x 17 x 4,5 x 3,4	30,24
BSF 5/16-22h.	7,938	6,60	D 90 x 20 x 6,0 x 4,9	35,94
BSF 3/8-20h.	9,525	8,10	D 100 x 22 x 7,0 x 5,5	37,76
BSF 7/16-18h.	11,113	9,50	D 100 x 22 x 8,0 x 6,2	50,89
BSF 1/2-16h.	12,700	11,00	D 110 x 24 x 9,0 x 7,0	57,58
BSF 9/16-16h.	14,287	12,50	D 110 x 25 x 11,0 x 9,0	60,94
BSF 5/8-14h.	15,876	14,00	D 110 x 27 x 12,0 x 9,0	81,25
BSF 3/4-12h.	19,051	16,50	D 125 x 30 x 14,0 x 11,0	96,16
BSF 7/8-11h.	22,226	19,50	D 140 x 32 x 18,0 x 14,5	133,68
BSF 1"-10h.	25,400	22,50	D 160 x 36 x 18,0 x 14,5	155,38

MASCHI PER FILETTARE A MACCHINA HSSCo

BSW

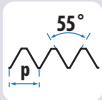

HSSCo
5%

TOL
Classe 2

Vc
12 m/min

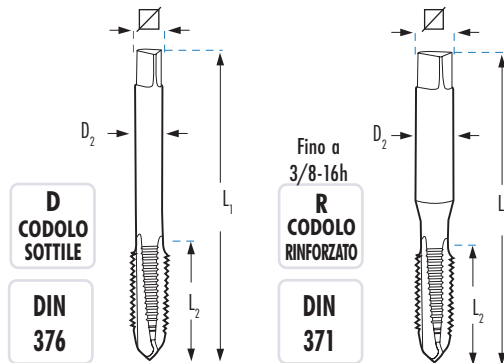



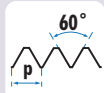
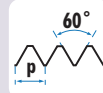
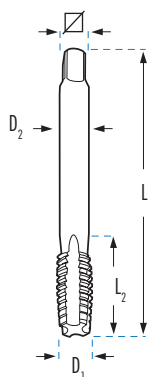
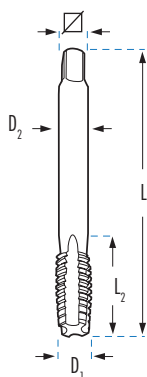

Icona	D1 mm	Ø	L1 x L2 x D2 x	M1R M2R M3R M4R			
				FORMA C	FORMA B	15°	35°
				€	€	€	€
W 3/32-48h.	2,38	1,80	R 50 x 9 x 2,8 x 2,1	21,51	20,97		
W 1/8-40h.	3,17	2,55	R 56 x 11 x 3,5 x 2,7	17,02 *	18,80	20,43	21,37
W 5/32-32h.	3,97	3,10	R 63 x 13 x 4,5 x 3,4	17,02	18,80	20,43	21,37
W 3/16-24h.	4,76	3,60	R 70 x 15 x 6,0 x 4,9	21,13	22,40	20,43	21,37
W 7/32-24h.	5,56	4,40	R 80 x 16 x 6,0 x 4,9	25,84	27,33		
W 1/4-20h.	6,35	5,10	R 80 x 17 x 7,0 x 5,5	18,20	19,01	23,18	23,94
W 5/16-18h.	7,94	6,50	R 90 x 20 x 8,0 x 6,2	21,60	24,10	27,06	28,30
W 3/8-16h.	9,52	7,90	R 100 x 22 x 10,0 x 8,0	22,82	26,96	30,06	31,45

CODOLO SOTTILE				M1D	M2D	M3D	M4D
W 7/16-14h.	11,11	9,25	D 100 x 22 x 8,0 x 6,2	31,73	34,89	39,71	39,98
W 1/2-12h.	12,70	10,50	D 110 x 24 x 9,0 x 7,0	30,44	33,14	38,03	39,77
W 9/16-12h.	14,29	12,00	D 110 x 26 x 11,0 x 9,0	43,63	45,82	54,55	57,05
W 5/8-11h.	15,87	13,40	D 110 x 27 x 12,0 x 9,0	41,31	45,38	51,58	53,94
W 3/4-10h.	19,05	16,50	D 125 x 30 x 14,0 x 11,0	57,81	63,61	69,11	72,27
W 7/8-9h.	22,22	19,25	D 140 x 32 x 18,0 x 14,5	74,87	82,31	93,53	93,53
W 1"-8h.	25,40	21,75	D 160 x 36 x 18,0 x 14,5	94,09	103,44	117,39	122,78
W 1.1/8-7h.	28,57	24,75	D 180 x 40 x 22,0 x 18,0	127,61	134,18	205,24	
W 1.1/4-7h.	31,75	27,75	D 180 x 40 x 22,0 x 18,0	185,39	183,95		
W 1.3/8-6h.	34,92	30,50	D 200 x 50 x 28,0 x 22,0	304,71	320,18		
W 1.1/2-6h.	38,10	33,50	D 200 x 50 x 32,0 x 24,0	330,74	347,85		
W 1.5/8-5h.	41,27	46,50	D 220 x 65 x 32,0 x 24,0	461,65	485,56		
W 1.3/4-5h.	44,45	39,00	D 220 x 58 x 36,0 x 29,0	476,20	523,82		
W 1.7/8-4,5h.	47,62	42,00	D 250 x 75 x 36,0 x 29,0	552,13	580,72		
W 2"-4,5h.	50,80	44,50	D 250 x 65 x 40,0 x 32,0	681,52			

* Disponibili anche con filettatura sinistra al doppio del prezzo.

MASCHI PER FILETTARE A MACCHINA HSSCo
UNJC

HSSCo
5%
TOL
3B
UNJF

HSSCo
5%
TOL
3B
Vc
12 m/min

Vc
12 m/min

	D1 mm		L1 x L2 x D2 x ∇ mm	M1R
				FORMA C
				€
UNJC n° 4-40h	2,84	2,25	R 56 x 11 x 3,5 x 2,7	42,71
UNJC n° 5-40h	3,17	2,60	R 56 x 11 x 3,5 x 2,7	42,71
UNJC n° 6-32h	3,50	2,75	R 56 x 12 x 4,0 x 3,0	42,71
UNJC n° 8-32h	4,17	3,50	R 63 x 13 x 4,5 x 3,4	42,71
UNJC n°10-24h	4,83	3,90	R 70 x 15 x 6,0 x 4,9	42,71
UNJC n°12-24h	5,49	4,50	R 80 x 16 x 6,0 x 4,9	44,80
UNJC 1/4-20h	6,35	5,10	R 80 x 17 x 7,0 x 5,5	39,86
UNJC 5/16-18h	7,94	6,60	R 90 x 20 x 8,0 x 6,2	45,10
UNJC 3/8-16h	9,52	8,00	R 100 x 22 x 8,0 x 6,2	51,41

	D1 mm		L1 x L2 x D2 x ∇ mm	M1R
				FORMA C
				€
UNJF n° 4-48h	2,84	2,35	R 56 x 11 x 3,5 x 2,7	46,86
UNJF n° 5-44h	3,17	2,70	R 56 x 11 x 3,5 x 2,7	46,86
UNJF n° 6-40h	3,50	2,95	R 56 x 12 x 4,0 x 3,0	46,86
UNJF n° 8-36h	4,17	3,50	R 63 x 13 x 4,5 x 3,4	46,86
UNJF n°10-32h	4,83	4,10	R 70 x 15 x 6,0 x 4,9	46,86
UNJF n°12-28h	5,49	4,60	R 80 x 16 x 6,0 x 4,9	46,86
UNJF 1/4-28h	6,35	5,50	R 80 x 17 x 7,0 x 5,5	36,37
UNJF 5/16-24h	7,94	6,90	R 90 x 20 x 8,0 x 6,2	40,68
UNJF 3/8-24h	9,52	8,50	R 90 x 16 x 7,0 x 6,2	44,53

CODOLO SOTTILE PASSI NORMALI			M1D	
UNJC 7/16-14h	11,11	9,40	D 110 x 24 x 9,0 x 7,0	70,90
UNJC 1/2-13h	12,70	10,75	D 110 x 26 x 11,0 x 9,0	76,97
UNJC 9/16-12h	14,28	12,20	D 110 x 27 x 12,0 x 9,0	105,77
UNJC 5/8-11h	15,87	13,50	D 110 x 27 x 12,0 x 9,0	115,55
UNJC 3/4-10h	19,05	16,50	D 125 x 30 x 14,0 x 11,0	136,04
UNJC 7/8-9h	22,22	19,50	D 140 x 32 x 18,0 x 14,5	179,00
UNJC 1"-8h	25,40	22,25	D 160 x 36 x 18,0 x 14,5	236,51

CODOLO SOTTILE PASSI NORMALI			M1D	
UNJF 7/16-20h	11,11	9,90	D 100 x 22 x 8,0 x 6,2	61,16
UNJF 1/2-20h	12,70	11,50	D 100 x 22 x 9,0 x 7,0	65,13
UNJF 9/16-18h	14,29	12,90	D 100 x 22 x 11,0 x 9,0	80,02
UNJF 5/8-18h	15,87	14,50	D 100 x 22 x 12,0 x 9,0	90,09
UNJF 3/4-16h	19,05	17,50	D 110 x 25 x 14,0 x 11,0	115,25
UNJF 7/8-14h	22,22	20,40	D 125 x 25 x 18,0 x 14,5	144,93
UNJF 1"-12h	25,40	23,25	D 140 x 28 x 18,0 x 14,5	161,60

MASCHI PER FILETTARE A MACCHINA HSSCo

BSPP  **HSSCo 5%** **DIN 374** **FORMA C**

BSPT  **HSSCo 5%** **DIN 5156** **FORMA C**

FILETTATURA CILINDRICA INGLESE PER TUBI

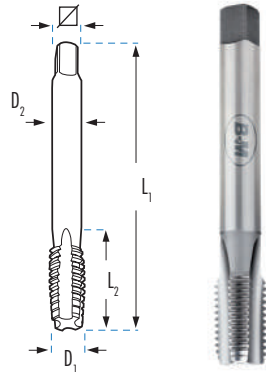

FILETTATURA CONICA INGLESE PER TUBI

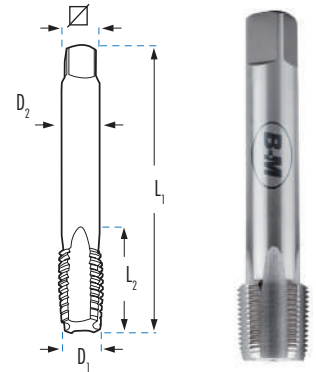

	D1 mm	L1 x L2 x D2 x ∇ mm	M1D €
Rp 1/16-28h.	7,72	D 90 x 16 x 6 x 4,9	
Rp 1/8-28h.	9,73	D 90 x 16 x 7 x 5,5	51,43
Rp 1/4-19h.	13,16	D 100 x 22 x 11 x 9,0	71,04
Rp 3/8-19h.	16,66	D 100 x 22 x 12 x 9,0	85,06
Rp 1/2-14h.	20,95	D 125 x 25 x 16 x 12,0	107,49
Rp 3/4-14h.	26,44	D 140 x 28 x 20 x 16,0	168,33
Rp 1"-11h.	33,25	D 160 x 30 x 25 x 20,0	261,18
Rp 1.1/4-11h.	41,91	D 170 x 30 x 32 x 24,0	
Rp 1.1/2-11h.	46,80	D 190 x 32 x 36 x 29,0	
Rp 2"-11h.	59,61	D 220 x 36 x 45 x 35,0	

	D1 mm	θ	L1 x L2 x D2 x ∇ mm	M1D €
Rc 1/16-28h.	7,72		D 90 x 14 x 6 x 4	
Rc 1/8-28h.	9,73	8,30	D 90 x 15 x 7 x 5	48,97
Rc 1/4-19h.	13,16	11,00	D 100 x 19 x 11 x 9	66,72
Rc 3/8-19h.	16,66	14,50	D 100 x 21 x 12 x 9	82,41
Rc 1/2-14h.	20,95	18,10	D 125 x 26 x 16 x 12	114,52
Rc 5/8-14h.	22,91	21,00	D 140 x 36 x 18 x 19	235,73
Rc 3/4-14h.	26,44	23,50	D 140 x 28 x 20 x 16	158,53
Rc 7/8-14h.	30,20	28,25	D 160 x 36 x 22 x 18	411,84
Rc 1"-11h.	33,25	29,60	D 160 x 33 x 25 x 20	294,41

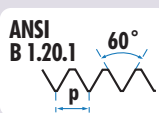
NPS (M)  **HSSCo 5%** **DIN 374** **FORMA C**

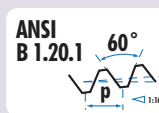
NPT  **HSSCo 5%** **DIN 374** **FORMA C**

FILETTATURA CILINDRICA AMERICANA PER TUBI

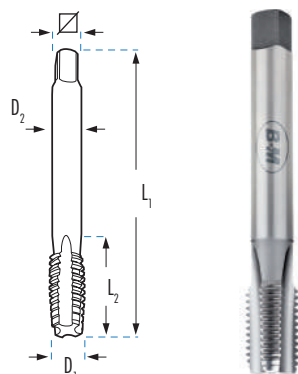

FILETTATURA CONICA AMERICANA PER TUBI

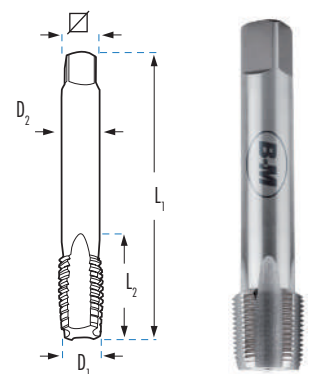

	D1 mm	θ	L1 x L2 x D2 x ∇ mm	M1D €
NPS 1/8-27h.	10,20	8,90	D 90 x 16 x 7 x 5,5	137,57
NPS 1/4-18h.	13,60	11,70	D 100 x 22 x 11 x 9,0	196,88
NPS 3/8-18h.	17,00	15,00	D 100 x 22 x 12 x 9,0	269,98
NPS 1/2-14h.	21,20	18,60	D 125 x 25 x 16 x 12,0	370,21
NPS 3/4-14h.	26,55	24,00	D 140 x 28 x 20 x 16,0	547,29
NPS 1"-11,5 h.	33,20	30,00	D 160 x 30 x 25 x 20,0	707,73
NPS 1.1/4-11,5h.	41,60		D 170 x 30 x 32 x 24,0	
NPS 1.1/2-11,5h.	47,68		D 190 x 32 x 36 x 29,0	
NPS 2"-11,5h.	59,71		D 220 x 36 x 45 x 35,0	

	D1 mm	θ	L1 x L2 x D2 x ∇ mm	M1D €
NPT 1/16-27h.	7,89	6,2	D 90 x 14 x 6 x 5	44,39
NPT 1/8-27h.	10,24	8,5	D 90 x 15 x 8 x 6	46,43
NPT 1/4-18h.	13,62	11,0	D 100 x 19 x 11 x 9	62,28
NPT 3/8-18h.	17,05	14,5	D 100 x 21 x 12 x 9	75,51
NPT 1/2-14h.	21,22	17,8	D 125 x 26 x 16 x 12	104,11
NPT 3/4-14h.	26,57	23,0	D 140 x 28 x 20 x 16	161,33
NPT 1"-11,5h.	33,23	29,0	D 160 x 33 x 25 x 20	209,66
NPT 1.1/4-11,5h.	41,98	37,5	D 170 x 36 x 32 x 24	275,78
NPT 1.1/2-11,5h.	48,05	44,0	D 190 x 37 x 36 x 29	450,79
NPT 2"-11,5h.	60,09	56,0	D 220 x 41 x 45 x 35	707,11

MASCHI PER FILETTARE A MACCHINA HSSCo

NPSF HSSCo 5% DIN 374 FORMA C

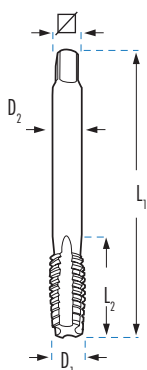
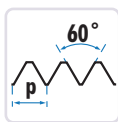

FILETTATURA PER TUBI
AMERICANA CILINDRICA

NPTF HSSCo 5% DIN 374 FORMA C

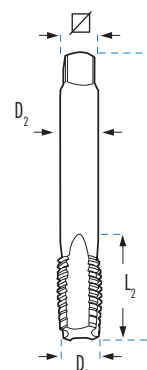
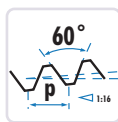

FILETTATURA PER TUBI
AMERICANA CONICA A TENUTA STAGNA

	D1 mm	\emptyset	L1 x L2 x D2 x ∇ mm	M1D €
NPSF 1/8-27h.	10,05	8,75	D 90 x 16 x 7 x 5,5	165,92
NPSF 1/4-18h.	13,33	11,30	D 100 x 22 x 11 x 9,0	228,71
NPSF 3/8-18h.	16,78	14,70	D 100 x 22 x 12 x 9,0	325,36
NPSF 1/2-14h.	20,87	18,20	D 125 x 25 x 16 x 12,0	405,73
NPSF 3/4-14h.	26,23	23,50	D 140 x 28 x 20 x 16,0	664,04
NPSF 1"-11,5h.	32,81	29,50	D 160 x 30 x 25 x 20,0	

	D1 mm	\emptyset	L1 x L2 x D2 x ∇ mm	M1D €
NPTF 1/16-27h.	7,87	6,20	D 90 x 14 x 12,0 x 6	
NPTF 1/8-27h.	10,22	8,50	D 90 x 15 x 12,0 x 7	105,77
NPTF 1/4-18h.	13,58	11,00	D 100 x 21 x 17,5 x 11	148,37
NPTF 3/8-18h.	17,02	14,50	D 110 x 21 x 17,6 x 12	190,62
NPTF 1/2-14h.	21,21	17,80	D 140 x 27 x 22,8 x 16	248,14
NPTF 3/4-14h.	26,56	23,00	D 140 x 27 x 23,0 x 20	384,41

MF HSSCo 5% TOL 6H DIN 374 FORMA C

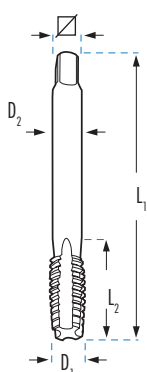
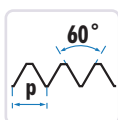

FILETTATURA METRICA FINE PER TUBI DI
CONDUZIONE ELETTRICA
EN 60423

PG HSSCo 5% DIN 40430 FORMA C

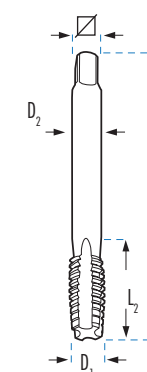
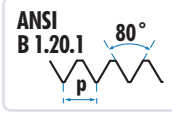

FILETTATURA PER TUBI
DI CONDUZIONE
ELETTRICA

	D1 mm	\emptyset	L1 x L2 x D2 x ∇ mm	M1D €
MF 12 x 1,50	12	10,5	D 100 x 22 x 9 x 7,0	26,44
MF 16 x 1,50	16	14,5	D 100 x 22 x 12 x 9,0	37,24
MF 20 x 1,50	20	18,5	D 125 x 25 x 16 x 12,0	55,83
MF 25 x 1,50	25	23,5	D 140 x 28 x 18 x 14,5	121,43
MF 32 x 1,50	32	30,5	D 150 x 28 x 22 x 18,0	151,42
MF 40 x 1,50	40	38,5	D 170 x 30 x 32 x 24,0	255,01
MF 50 x 1,50	50	48,5	D 190 x 32 x 36 x 29,0	397,03
MF 63 x 1,50	63	61,5	D 275 x 36 x 50 x 39,0	

	D1 mm	\emptyset	L1 x L2 x D2 x ∇ mm	M1D €
PG 7 - 20h.	12,5	11,50	D 100 x 22 x 9 x 7,0	49,19
PG 9 - 18h.	15,2	14,00	D 100 x 22 x 12 x 9,0	68,11
PG 11 - 18h.	18,6	17,25	D 110 x 25 x 14 x 11,0	88,65
PG 13,5 - 18h.	20,4	19,00	D 125 x 25 x 16 x 12,0	99,54
PG 16 - 18h.	22,5	21,25	D 125 x 25 x 18 x 14,5	117,15
PG 21 - 16h.	28,3	27,00	D 150 x 28 x 22 x 18,0	185,99
PG 29 - 16h.	37,0	35,50	D 170 x 30 x 28 x 22,0	314,39
PG 36 - 16h.	47,0	45,50	D 190 x 32 x 36 x 29,0	510,60
PG 42 - 16h.	54,0	52,50	D 190 x 32 x 40 x 32,0	810,94
PG 48 - 16h.	59,3	58,00	D 220 x 36 x 45 x 35,0	988,59

MASCHI PER FILETTARE A MACCHINA HSSCo

UNx8 HSSCo 5% DIN 374 FORMA C TOL 2B

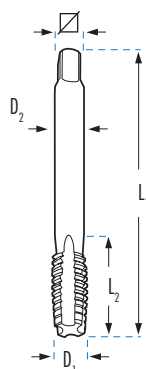
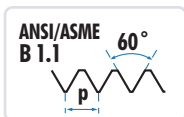

UNEF HSSCo 5% DIN 374 TOL 2B

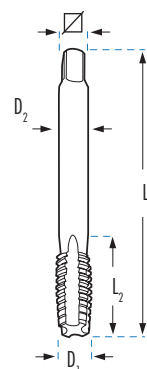
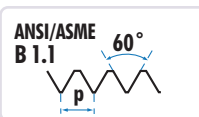

				M1D
		D2 mm	L1 x L2 x mm	FORMA C €
UN 1" 1/8-8h.	25,40	22	180 x 45 x 18	307,69
UN 1" 1/4-8h.	28,50	22	180 x 48 x 18	396,95
UN 1" 3/8-8h.	31,75	28	200 x 56 x 22	450,29
UN 1" 1/2-8h.	35,00	32	200 x 58 x 22	537,46
UN 1" 5/8-8h.	38,10	32	200 x 65 x 24	628,71
UN 1" 3/4-8h.	41,25	36	200 x 50 x 29	765,89
UN 1" 7/8-8h.	44,45	36	225 x 53 x 29	856,95
UN 2"-8h.	47,63	40	225 x 50 x 32	902,69

				M2D	M4D
		D2 mm	L1 x L2 x mm	FORMA B €	35° €
UNEF 1/4-32h.	5,55	7,0	R 82 x 16 x 5,4	101,20	113,72
UNEF 5/16-32h.	7,15	8,4	R 85 x 21 x 6,1	111,49	125,27
UNEF 3/8-32h.	8,70	7,0	D 95 x 22 x 5,4	111,56	125,35
UNEF 7/16-28h.	10,20	8,0	D 100 x 22 x 6,2	148,06	166,37
UNEF 1/2-28h.	11,80	9,0	D 100 x 22 x 7,0	155,97	175,23
UNEF 9/16-24h.	13,20	12,0	D 100 x 24 x 9,0	195,39	219,56
UNEF 5/8-24h.	14,80	12,0	D 100 x 24 x 9,0	222,34	249,83
UNEF 3/4-20h.	17,80	14,0	D 110 x 27 x 11,0	289,18	324,94
UNEF 7/8-20h.	20,95	18,0	D 125 x 26 x 14,5	310,85	333,05
UNEF 1"-20h.	24,20	18,0	D 140 x 28 x 14,5	475,70	534,48

MASCHI PER FILETTARE A MACCHINA HSSCo A SINISTRA

MM MF HSSCo 5% FORMA C TOL 6H

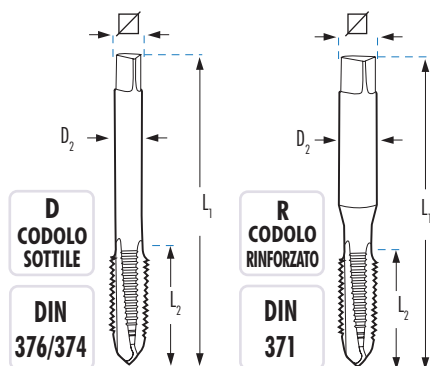
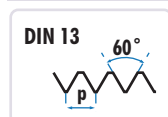

				M1R1
			L1 x L2 x D2 x mm	FORMA C €
M 3x0,50	2,50	R	56 x 11 x 3,5 x 2,7	23,90
M 4x0,70	3,30	R	63 x 13 x 4,5 x 3,4	26,67
M 5x0,80	4,20	R	70 x 16 x 6,0 x 4,9	24,34
M 6x1,00	5,00	R	80 x 17 x 6,0 x 4,9	26,86
M 7x1,00	6,00	R	80 x 17 x 7,0 x 5,5	35,93
M 8x1,25	6,80	R	90 x 20 x 8,0 x 6,2	31,29
M 10x1,50	8,50	R	100 x 22 x 10,0 x 8,0	34,82

				M1D1
			L1 x L2 x D2 x mm	FORMA C €
M 12x1,50	10,50	D	100 x 22 x 9,0 x 7,0	52,88
M 12x1,75	10,20	D	110 x 24 x 9,0 x 7,0	38,14
M 14x1,50	12,50	D	100 x 22 x 11,0 x 9,0	63,00
M 14x2,00	12,00	D	110 x 26 x 11,0 x 9,0	62,56
M 16x1,50	14,50	D	100 x 22 x 12,0 x 9,0	74,49
M 16x2,00	14,00	D	110 x 27 x 12,0 x 9,0	73,61
M 18x1,50	16,50	D	110 x 25 x 14,0 x 11,0	98,57
M 18x2,50	15,50	D	125 x 30 x 14,0 x 11,0	99,92
M 20x1,50	18,50	D	125 x 25 x 16,0 x 12,0	111,66
M 20x2,50	17,50	D	140 x 32 x 16,0 x 12,0	112,73
M 22x2,50	19,50	D	140 x 32 x 18,0 x 14,5	136,44
M 24x2,00	22,00	D	140 x 28 x 18,0 x 14,5	198,91
M 24x3,00	21,00	D	160 x 34 x 18,0 x 14,5	163,34
M 27x3,00	24,00	D	160 x 36 x 20,0 x 16,0	203,91
M 30x2,00	28,00	D	150 x 28 x 22,0 x 18,0	289,63
M 30x3,50	26,50	D	180 x 40 x 22,0 x 18,0	261,28
M 33x3,50	29,50	D	180 x 40 x 25,0 x 20,0	313,95
M 36x4,00	32,00	D	200 x 50 x 28,0 x 22,0	374,39

Consultare altre misure disponibili su richiesta.

MASCHI A MACCHINA METRICA NORMA ISO 529

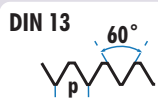
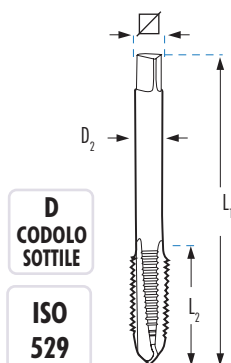
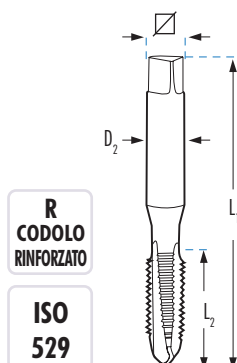
M
MFHSSCo
5%ISO
529TOL
6HD
CODOLO
SOTTILE
ISO
529R
CODOLO
RINFORZATO
ISO
529

			L1 x L2 x D2 x \square mm	M1RISO	M2RISO	M4RISO	M5RISO
				FORMA C	FORMA B	35°	DENTI ALTERNATI AI
				€	€	€	€
M 3x0,50	2,50	R	48 x 11 x 3,15 x 2,50	8,88	9,26	11,15	12,02
M 4x0,70	3,30	R	53 x 13 x 4,00 x 3,15	8,88	9,26	11,15	12,02
M 5x0,80	4,20	R	58 x 16 x 5,00 x 4,00	8,88	9,26	11,15	12,02
M 6x1,00	5,00	R	66 x 19 x 6,30 x 5,00	8,88	9,26	11,39	12,02
M 7x1,00	6,00	R	66 x 19 x 7,10 x 5,60		12,63	15,47	
M 8x1,00	7,00	R	69 x 19 x 8,00 x 6,30		16,34	16,16	
M 8x1,25	6,75	R	72 x 22 x 8,00 x 6,30	11,87	12,37	12,78	13,14
M 9x1,25	7,75	R	76 x 20 x 10,00 x 8,00		17,66	19,37	
M 10x1,00	9,00	R	76 x 20 x 10,00 x 8,00		18,75	20,49	
M 10x1,25	8,80	R	76 x 20 x 10,00 x 8,00		22,41	23,14	
M 10x1,50	8,50	R	80 x 24 x 10,00 x 8,00	15,09	15,72	16,46	16,57
CODOLO SOTTILE				M1DISO	M2DISO	M4DISO	M5DISO
M 12x1,00	11,00	D	84 x 24 x 9,00 x 7,10		27,91	28,33	
M 12x1,25	10,75	D	84 x 24 x 9,00 x 7,10		28,19	28,13	
M 12x1,50	10,50	D	89 x 29 x 9,00 x 7,10		25,17	26,09	
M 12x1,75	10,20	D	89 x 29 x 9,00 x 7,10	17,56	20,20	21,40	24,80
M 14x1,00	13,00	D	90 x 25 x 11,20 x 9,00		35,83	43,72	
M 14x1,25	12,80	D	90 x 25 x 11,20 x 9,00		31,41	39,48	
M 14x1,50	12,50	D	95 x 30 x 12,50 x 9,00		24,94	31,12	
M 14x2,00	12,00	D	95 x 30 x 11,20 x 9,00	23,18	24,15	29,24	
M 16x1,00	15,00	D	95 x 25 x 12,50 x 10,00		49,05	50,65	
M 16x1,25	14,75	D	102 x 32 x 12,50 x 10,00		49,49	50,85	
M 16x1,50	14,50	D	102 x 32 x 14,00 x 10,00		34,70	38,98	
M 16x2,00	14,00	D	102 x 32 x 12,50 x 10,00	28,79	29,99	33,92	
M 18x1,50	16,50	D	104 x 29 x 14,00 x 11,20		45,86	55,66	
M 18x2,50	15,50	D	112 x 37 x 14,00 x 11,20	43,35	45,15	56,45	
M 20x1,50	18,50	D	104 x 29 x 14,00 x 11,20		52,15	59,87	
M 20x2,50	17,50	D	112 x 37 x 14,00 x 11,20	48,45	50,47	59,52	
M 22x2,50	19,50	D	118 x 38 x 16,00 x 12,50	56,03	58,36	72,95	
M 24x3,00	21,00	D	130 x 45 x 18,00 x 14,00	63,29	65,93	82,40	
M 27x3,00	24,00	D	135 x 45 x 20,00 x 16,00	77,94	81,19	101,48	
M 30x3,50	26,50	D	138 x 48 x 20,00 x 16,00	115,79	120,62	142,24	

MASCHI A MACCHINA CORTI DIN 352

M
MF

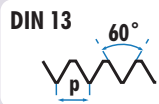

HSS

HSSCo
5%

DIN
352

TOL
6H

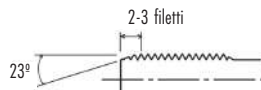

Ref. M03: Cono di entrata 2-3 filetti

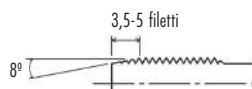

Ref. M02AT: Cono di entrata 3,5-5 filetti

D
CODOLO
SOTTILE

DIN
352

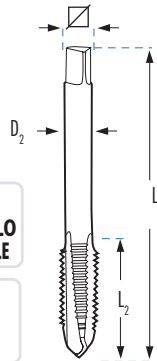

		L ₁ x L ₂ x D ₂ x  mm	M03	M02AT	M03X	M02DIN	M04DIN
			HSS	ALTEZZA FINITA HSS	INOX HSSCo	FORMA B HSS	 35° HSS
			€	€	€	€	€
M 3x0,50	2,50	D 40 x 11 x 3,50 x 2,70	5,05	6,70	11,43	10,19	12,26
M 4x0,70	3,30	D 45 x 13 x 4,50 x 3,40	5,05	6,69	11,43	10,19	12,26
M 5x0,80	4,20	D 50 x 16 x 6,00 x 4,90	5,64	7,47	11,59	10,19	12,26
M 6x1,00	5,00	D 50 x 19 x 6,00 x 4,90	5,70	7,56	11,57	10,19	12,54
M 7x1,00	6,00	D 50 x 19 x 6,00 x 4,90	7,51				
M 8x1,00	7,00	D 56 x 18 x 6,00 x 4,90	10,63				
M 8x1,25	6,75	D 56 x 22 x 6,00 x 4,90	6,23	8,26	13,28	13,59	15,84
M 9x1,25	7,75	D 63 x 18 x 7,00 x 5,50	8,46				
M 10x1,00	9,00	D 63 x 18 x 7,00 x 5,50	12,50				
M 10x1,25	8,80	D 70 x 24 x 7,00 x 5,50	11,64				
M 10x1,50	8,50	D 70 x 24 x 7,00 x 5,50	8,02	10,64	17,76	17,28	19,31
M 12x1,00	11,00	D 70 x 20 x 9,00 x 7,00	20,49				
M 12x1,25	10,75	D 70 x 20 x 9,00 x 7,00	20,42				
M 12x1,50	10,50	D 70 x 20 x 9,00 x 7,00	18,84				
M 12x1,75	10,20	D 75 x 29 x 9,00 x 7,00	10,11	13,40	23,18	20,98	25,62
M 14x1,00	13,00	D 70 x 20 x 11,00 x 9,00	31,82				
M 14x1,25	12,80	D 70 x 20 x 11,00 x 9,00	23,74				
M 14x1,50	12,50	D 70 x 20 x 11,00 x 9,00	20,34				
M 14x2,00	12,00	D 80 x 30 x 11,00 x 9,00	13,02	17,25	29,24	26,57	32,16
M 16x1,00	15,00	D 70 x 20 x 12,00 x 9,00	34,70				
M 16x1,25	14,75	D 70 x 20 x 12,00 x 9,00	34,91				
M 16x1,50	14,50	D 70 x 20 x 12,00 x 9,00	25,00				
M 16x2,00	14,00	D 80 x 32 x 12,00 x 9,00	15,61		35,67	32,99	37,31
M 18x1,50	16,50	D 80 x 22 x 14,00 x 11,00	25,51				
M 18x2,50	15,50	D 95 x 40 x 14,00 x 11,00	20,74		46,72	48,84	55,89
M 20x1,50	18,50	D 80 x 22 x 16,00 x 12,00	27,63				
M 20x2,50	17,50	D 95 x 40 x 16,00 x 12,00	22,89		52,59	55,52	58,93
M 22x2,50	19,50	D 100 x 40 x 18,00 x 14,50	32,02			64,19	72,23
M 24x3,00	21,00	D 110 x 50 x 18,00 x 14,50	37,10			72,52	81,59
M 27x3,00	24,00	D 110 x 50 x 20,00 x 16,00	48,29			94,49	103,74
M 30x3,50	26,50	D 125 x 50 x 22,00 x 18,00	61,19			129,43	132,94

MASCHI A MACCHINA E FILIERE SERIE *Plus* E *Super Plus*

Maschi e Filiere

Rosa

DIN 13

60°

TOL
6H

PER LAVORAZIONI DI ALTA PRODUZIONE
FABBRICATI IN ACCIAIO SINTERIZZATO

DIN
22568

TOL
6g



Plus

Plus TiN

Plus LUBE

Super Plus AlTiN

QUALITÀ	M2RP		M4RP		M2RT		M4RT		M2RHL		M4RHL		M2RSP		M4RSP		C5P	
	★★	★★	★★★	★★★	★★★★	★★★★	★★★★	★★★★	★★★★	★★★★	★★★★	★★★★	★★★★	★★★★	★★★★	★★★★	★★★★	★★★★
MATERIALE	HSS PM	HSS PM	HSSCo 5%	HSSCo 5%	HSS PM	HSS PM	HSS V3	HSS V3	HSS V3	HSS V3	HSS V3	HSS V3	HSS V3	HSS V3	HSS V3	HSS V3	HSS	HSS
FINITURA	BRILLANTE	BRILLANTE	TiN	TiN	HARD LUBE	HARD LUBE	ALTiN	ALTiN	ALTiN	ALTiN	ALTiN	ALTiN	ALTiN	ALTiN	ALTiN	ALTiN	BRILLANTE	BRILLANTE
ANGOLO DELL'ELICA	FORMA B	FORMA B	FORMA B	FORMA B	FORMA B	FORMA B	FORMA B	FORMA B	FORMA B	FORMA B	FORMA B	FORMA B	FORMA B	FORMA B	FORMA B	FORMA B	FORMA B	FORMA B
	L1 x L2 x D2 x	L1 x L2 x D2 x	L1 x L2 x D2 x	L1 x L2 x D2 x	L1 x L2 x D2 x	L1 x L2 x D2 x	L1 x L2 x D2 x	L1 x L2 x D2 x	L1 x L2 x D2 x	L1 x L2 x D2 x	L1 x L2 x D2 x	L1 x L2 x D2 x	L1 x L2 x D2 x	L1 x L2 x D2 x	L1 x L2 x D2 x	L1 x L2 x D2 x	∅ x L ₃	∅
	mm	mm	mm	mm	mm	mm	mm	mm	mm	mm	mm	mm	mm	mm	mm	mm	mm	mm
	€	€	€	€	€	€	€	€	€	€	€	€	€	€	€	€	€	€
M 3x0,50	2,50	R	56 x 11 x 3,5 x 2,7	14,31	17,68	20,78	23,37	23,88	25,86	44,51	46,58	25 x 9	26,85					
M 4x0,70	3,30	R	63 x 13 x 4,5 x 3,4	14,62	17,68	21,91	24,41	24,23	26,21	44,51	46,58	25 x 9	26,85					
M 5x0,80	4,20	R	70 x 16 x 6,0 x 4,9	14,62	16,96	21,91	23,92	24,23	26,21	47,00	48,29	25 x 9	26,85					
M 6x1,00	5,00	R	80 x 17 x 6,0 x 4,9	16,09	18,61	24,30	26,31	26,63	27,74	47,00	48,29	25 x 9	26,85					
M 8x1,00	7,00	D	90 x 20 x 6,0 x 4,9	22,94	27,24	31,74	35,31	37,46	41,70			25 x 9	36,07					
M 8x1,25	6,80	R	90 x 20 x 8,0 x 6,2	18,84	21,63	28,14	30,88	31,42	35,29	59,66	63,58	25 x 9	28,06					
M 10x1,00	9,00	D	90 x 16 x 7,0 x 5,5	25,60	32,11	37,07	42,57	43,75	51,70			30 x 10	44,09					
M 10x1,50	8,50	R	100 x 22 x 10,0 x 8,0	22,14	25,19	33,60	36,65	38,94	43,92	71,10	75,84	30 x 10	40,04					
CODOLO SOTTILE			M2DP	M4DP	M2DT	M4DT	M2DHL	M4DHL	M2DSP	M4DSP								
M 12x1,50	10,50	D	100 x 22 x 9,0 x 7,0	30,37	36,70	42,43	47,80	48,97	56,18			38 x 10	49,88					
M 12x1,75	10,20	D	110 x 24 x 9,0 x 7,0	28,54	33,88	41,63	46,52	43,49	52,68	89,46	97,05	38 x 14	44,03					
M 14x1,50	12,50	D	100 x 22 x 11,0 x 9,0	35,96	45,11	49,00	56,20	57,60	66,05			38 x 10	52,14					
M 14x2,00	12,00	D	110 x 26 x 11,0 x 9,0	35,69	41,38	50,89	55,95	58,21	63,98	91,35	122,99	38 x 14	44,89					
M 16x1,50	14,50	D	100 x 22 x 12,0 x 9,0	45,00	55,48	58,87	67,34	64,46	66,38			45 x 14	71,61					
M 16x2,00	14,00	D	110 x 27 x 12,0 x 9,0	41,99	50,00	58,12	65,46	66,44	73,45	124,69	132,63	45 x 18	60,29					
M 18x2,50	15,50	D	125 x 30 x 14,0 x 11,0	59,49	67,23	73,63	80,33	88,57	99,74	185,06	200,22	45 x 18	60,29					
M 20x2,50	17,50	D	140 x 32 x 16,0 x 12,0	64,30	71,67	83,92	90,42	98,64	112,30	197,23	208,48	45 x 18	60,29					
M 22x2,50	19,50	D	140 x 32 x 18,0 x 14,5	77,79	88,43	98,42	107,40	115,67	126,22			55 x 22	90,48					
M 24x3,00	21,00	D	160 x 34 x 18,0 x 14,5	92,48	105,87	110,91	122,86	130,34	144,38			55 x 22	90,48					

MASCHI A MACCHINA PER LAVORAZIONI SPECIALI HSS-PM

INOX

M

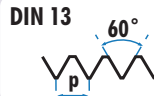

**TOL
6H**

**Vc
6 m/min**

**Vc
10 m/min**

**Vc
12 m/min**

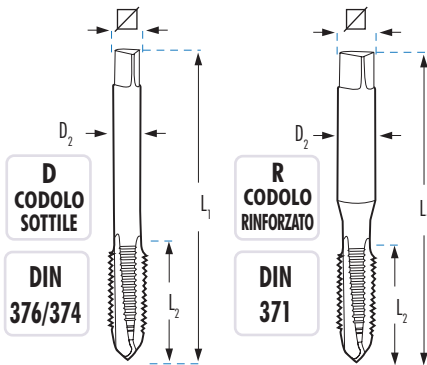

				M2RX	M4RX	M2RXT	M4RXT	M2RXHL	M4RXHL
QUALITÀ				★★	★★	★★★	★★★	★★★★	★★★★
MATERIALE				HSS PM	HSS PM	HSSCo 5%	HSSCo 5%	HSS PM	HSS PM
FINITURA				OX	OX	TiN	TiN	HARD LUBE	HARD LUBE
ANGOLO DELL'ELICA				FORMA B	35°	FORMA B	35°	FORMA B	35°
			L ₁ x L ₂ x D ₂ x ∅ mm	€	€	€	€	€	€
M 3x0,50	2,50	R	56 x 11 x 3,5 x 2,7	17,72	20,57	20,72	24,36	27,94	32,87
M 4x0,70	3,30	R	63 x 13 x 4,5 x 3,4	17,96	20,57	21,75	25,26	29,36	34,40
M 5x0,80	4,20	R	70 x 16 x 6,0 x 4,9	18,62	21,99	21,75	25,48	29,36	34,40
M 6x1,00	5,00	R	80 x 17 x 6,0 x 4,9	18,72	22,68	23,81	26,80	32,14	36,16
M 8x1,00	7,00	D	90 x 20 x 6,0 x 4,9	39,04	42,78				
M 8x1,25	6,80	R	90 x 20 x 8,0 x 6,2	21,95	26,16	26,59	30,57	35,89	41,24
M 10x1,00	9,00	D	90 x 16 x 7,0 x 5,5	40,24	42,96				
M 10x1,50	8,50	R	100 x 22 x 10,0 x 8,0	25,49	30,66	32,49	36,23	43,85	48,89
CODOLO SOTTILE				M2DX	M4DX	M2DXT	M4DXT	M2DXHL	M4DXHL
M 12x1,00	11,00	D	100 x 22 x 9,0 x 7,0	45,63	52,35				
M 12x1,50	10,50	D	100 x 22 x 9,0 x 7,0	46,32	54,77				
M 12x1,75	10,20	D	110 x 24 x 9,0 x 7,0	32,35	46,07	41,73	52,20	58,78	68,84
M 14x2,00	12,00	D	110 x 26 x 11,0 x 9,0	42,42	60,55	55,45	65,29	78,12	86,51
M 16x2,00	14,00	D	110 x 27 x 12,0 x 9,0	46,55	66,39	61,36	83,61	86,99	104,64
M 18x2,50	15,50	D	125 x 30 x 14,0 x 11,0	66,69	94,45	94,36	117,02	139,59	148,88
M 20x2,50	17,50	D	140 x 32 x 16,0 x 12,0	68,80	111,28	108,82	120,40	148,38	157,19
M 22x2,50	19,50	D	140 x 32 x 18,0 x 14,5	130,49	137,88	148,21	176,54		
M 24x3,00	21,00	D	160 x 34 x 18,0 x 14,5	137,19	157,47	151,10	180,56		
M 27x3,00	24,00	D	160 x 36 x 20,0 x 16,0	179,71	206,27				
M 30x3,50	26,50	D	180 x 40 x 22,0 x 18,0	229,81	263,78				



- Lubrificazione: **CUT MAGIC XTHICK**
- Si raccomanda l'applicazione dell'olio da taglio CUT MAGIC XTHICK per ottimizzare il processo di filettatura in Inox, Inconel, Titanio, Duplex, ecc...

Ref. ACXT00250

MASCHI *Super Plus* PER FILETTATURA DI LEGHE REFRATTIVE

M

DIN 13

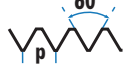
TOL
6HINOX
DUPLEX

Ni

INC

Ti

 PARTICOLARMENTE RACCOMANDATO
 IN APPLICAZIONI AERONAUTICHE
Vc
15
m/minINOX
DUPLEXVc
6
m/minNICKEL
INCONELVc
6
m/min

TITANIO

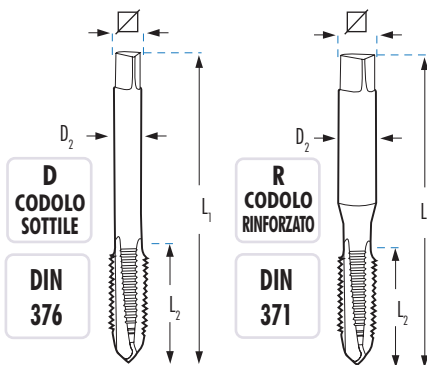

			M2RDU	M4RDU	M2RNI	M3RNI	M2RTIT	M3RTIT
QUALITÀ			★★★★	★★★★	★★★★	★★★★	★★★★	★★★★
MATERIALE			HSS V3	HSS V3	HSS PM	HSS PM	HSS PM	HSS PM
FINITURA			TiCN	TiCN	BRILLANTE	BRILLANTE	OX	OX
ANGOLO DELL'ELICA			FORMA B	41°	FORMA B	15°	FORMA B	15°
		L1 x L2 x D2 x ∇ mm	€	€	€	€	€	€
M 3x0,50	2,50	R 56 x 11 x 3,5 x 2,7	45,12	46,22	83,85	85,68	62,24	68,70
M 4x0,70	3,30	R 63 x 13 x 4,5 x 3,4	45,12	46,52	85,68	87,99	64,20	68,70
M 5x0,80	4,20	R 70 x 16 x 6,0 x 4,9	46,63	47,54	88,69	90,78	65,81	73,19
M 6x1,00	5,00	R 80 x 17 x 6,0 x 4,9	47,93	48,96	89,40	91,92	65,81	74,20
M 8x1,25	6,80	R 90 x 20 x 8,0 x 6,2	66,94	69,78	101,02	103,71	76,04	85,68
M 10x1,50	8,50	R 100 x 22 x 10,0 x 8,0	86,75	89,01	120,04	123,70	94,19	103,23
CODOLO SOTTILE			M2DDU	M4DDU	M2DNI	M3DNI	M2DTIT	M3DTIT
M 12x1,75	10,20	D 110 x 24 x 9,0 x 7,0	117,30	126,65	154,38	170,71	118,20	128,28
M 14x2,00	12,00	D 110 x 26 x 11,0 x 9,0						
M 16x2,00	14,00	D 110 x 27 x 12,0 x 9,0	172,48	184,43				
M 18x2,50	15,50	D 125 x 30 x 14,0 x 11,0						
M 20x2,50	17,50	D 140 x 32 x 16,0 x 12,0	255,40	275,88				
M 22x2,50	19,50	D 140 x 32 x 18,0 x 14,5						
M 24x3,00	21,00	D 160 x 34 x 18,0 x 14,5	345,93	351,84				
M 27x3,00	24,00	D 160 x 36 x 20,0 x 16,0	444,42	465,86				
M 30x3,50	26,50	D 180 x 40 x 22,0 x 18,0	524,87	549,21				

MASCHI A MACCHINA PER ACCIAIO STRUTTURALI EXTRA DOLCE < DE 450 N/mm²

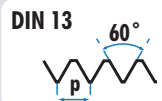

HSSCo
5%

OX

TOL
6H

APPLICAZIONI

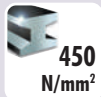



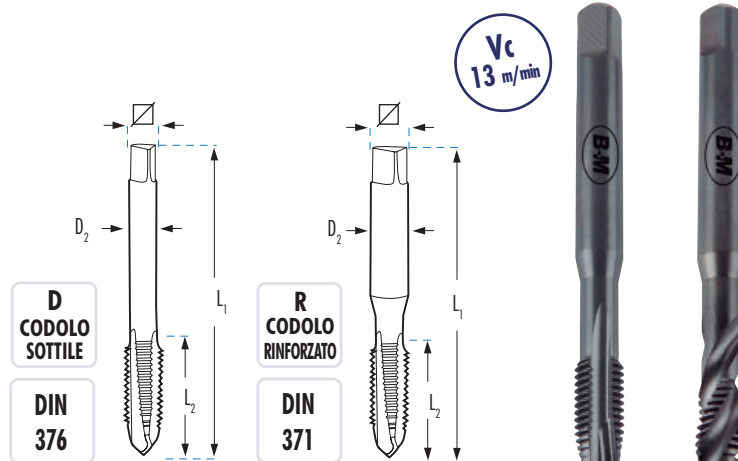

ST52

Al

Geometria di taglio specifica per materiali morbidi, non genera sovradimensionamento e si adatta perfettamente a questo tipo di materiali in cui i maschi convenzionali possono causare allargamenti durante la generazione del filo.

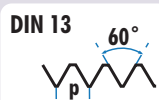

		L ₁ x L ₂ x D ₂ x  mm	M2RSS	M4RSS
			FORMA B	 35°
			€	€
M 3 x 0,50	2,50	R 56 x 11 x 3,5 x 2,7	14,90	19,60
M 4 x 0,70	3,30	R 63 x 13 x 4,5 x 3,4	15,73	19,62
M 5 x 0,80	4,20	R 70 x 16 x 6,0 x 4,9	15,83	18,81
M 6 x 1,00	5,00	R 80 x 17 x 6,0 x 4,9	16,77	20,65
M 8 x 1,25	6,80	R 90 x 20 x 8,0 x 6,2	19,39	23,90
M 10 x 1,50	8,50	R 100 x 22 x 10,0 x 8,0	23,88	28,30
CODOLO SOTTILE			M2DSS	M4DSS
M 12 x 1,75	10,20	D 110 x 24 x 9,0 x 7,0	27,09	32,80
M 14 x 2,00	12,00	D 110 x 26 x 11,0 x 9,0	38,68	45,51
M 16 x 2,00	14,00	D 110 x 27 x 12,0 x 9,0	43,16	52,52
M 18 x 2,50	15,50	D 125 x 30 x 14,0 x 11,0	61,48	74,00
M 20 x 2,50	17,50	D 140 x 32 x 16,0 x 12,0	71,97	78,99
M 22 x 2,50	19,50	D 140 x 32 x 18,0 x 14,5	86,38	96,29
M 24 x 3,00	21,00	D 160 x 34 x 18,0 x 14,5	101,77	117,02
M 27 x 3,00	24,00	D 160 x 36 x 20,0 x 16,0	128,71	143,99
M 30 x 3,50	26,50	D 180 x 40 x 22,0 x 18,0	165,36	184,53

MASCHI A MACCHINA PER LAVORAZIONI SPECIALI HSS-V3

**HSS
V3**
**TOL
6H**
**MATERIALI
DURI**

			M2RMD	M4RMD	M2RMDTX	M4RMDTX
QUALITÀ			★★★	★★★	★★★★	★★★★
MATERIALE			HSS V3	HSS V3	HSS V3	HSS V3
FINITURA			OX	OX	TINALOX	TINALOX
ANGOLO DELL'ELICA			FORMA B	35°	FORMA B	35°
		$L1 \times L2 \times D2 \times \square$ mm	€	€	€	€
M 3x0,50	2,50	R 56 x 11 x 3,5 x 2,7	18,35	21,08	26,17	30,77
M 4x0,70	3,30	R 63 x 13 x 4,5 x 3,4	19,07	21,08	27,49	32,21
M 5x0,80	4,20	R 70 x 16 x 6,0 x 4,9	19,07	20,97	27,49	32,21
M 6x1,00	5,00	R 80 x 17 x 6,0 x 4,9	20,90	23,06	30,10	33,87
M 8x1,25	6,80	R 90 x 20 x 8,0 x 6,2	23,55	25,78	33,61	38,64
M 10x1,50	8,50	R 100 x 22 x 10,0 x 8,0	27,14	29,97	42,53	47,44
CODOLO SOTTILE			M2DMD	M4DMD	M2DMDTX	M4DMDTX
M 12x1,75	10,20	D 110 x 24 x 9,0 x 7,0	38,69	42,29	56,64	66,30
M 14x2,00	12,00	D 110 x 26 x 11,0 x 9,0	48,11	55,89	80,61	88,48
M 16x2,00	14,00	D 110 x 27 x 12,0 x 9,0	56,76	67,61	89,79	107,04
M 18x2,50	15,50	D 125 x 30 x 14,0 x 11,0	80,24	96,20	132,00	149,49
M 20x2,50	17,50	D 140 x 32 x 16,0 x 12,0	86,71	101,58	142,66	157,79

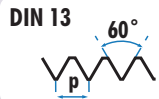
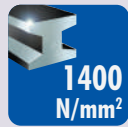
MASCHI A MACCHINA PER MATERIALI TEMPRATI (HARDOX 450/500)



TOL
6H

HSSE

HSS
PM

MD

MATERIALI
MOLTO
DURI

48
HRc

48-62
HRc



MD

Vc
5 m/min



48
HRc

DIN 371 6HX



48-62
HRc

Materiali molto duri

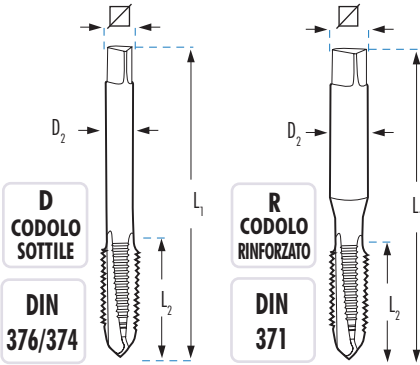

				M2RC	M3RC	M2HRC	M4HRC	M1RCM		M1RHMC	
		MATERIALE		HSSE	HSSE	HSS PM	HSS PM	HSS PM		MD	
		FINITURA		TiAlN	TiAlN	TiAlOX	TiAlOX	TiCN		TiCN	
		FORMA		FORMA B	15°	FORMA B	35°	FORMA C		FORMA C	
		L1 x L2 x D2 x ∅		€	€	€	€	€	€	€	€
M	3 x 0,50	2,50	R 56 x 11 x 3,5 x 2,7	29,52	31,41	41,71	46,70	2,60	47,28	2,60	122,41
M	4 x 0,70	3,30	R 63 x 13 x 4,5 x 3,4	29,58	33,44	43,31	48,52	3,40	41,59	3,40	122,41
M	5 x 0,80	4,20	R 70 x 16 x 6,0 x 4,9	29,85	32,68	43,73	48,97	4,30	46,47	4,30	122,41
M	6 x 1,00	5,00	R 80 x 17 x 6,0 x 4,9	32,28	36,18	45,61	51,08	5,10	59,50	5,10	153,01
M	8 x 1,25	6,80	R 90 x 20 x 8,0 x 6,2	37,29	42,55	56,70	63,50	6,90	66,00	6,90	172,21
M	10 x 1,50	8,50	R 100 x 22 x 10,0 x 8,0	44,64	52,71	67,86	71,25	8,60	85,56	8,60	264,23
		CODOLO SOTTILE		M2DC	M3DC	M2HDC	M4HDC	M1RCM		M1DHMC	
M	12 x 1,75	10,20	D 110 x 24 x 9,0 x 7,0	66,74	79,22	103,59	112,92	10,40	113,20 *	10,40	413,84
M	14 x 2,00	12,00	D 110 x 26 x 11,0 x 9,0	90,11	105,40	122,84	133,90	12,10	143,12 *	12,10	532,91
M	16 x 2,00	14,00	D 110 x 27 x 12,0 x 9,0	101,68	121,07	136,59	148,89	14,10	153,09 *	16,10	695,86
M	18 x 2,50	15,50	D 125 x 30 x 14,0 x 11,0	128,75	140,20	144,48	157,48			15,75	850,13
M	20 x 2,50	17,50	D 140 x 32 x 16,0 x 12,0	155,93	162,29	199,67	217,64			17,75	1.344,76
M	22 x 2,50	19,50	D 140 x 32 x 18,0 x 14,5	220,88	230,33						
M	24 x 3,00	21,00	D 160 x 34 x 18,0 x 14,5	226,13	236,63	269,93	294,22				
M	27 x 3,00	24,00	D 160 x 36 x 20,0 x 16,0	241,76	254,48						
M	30 x 3,50	26,50	D 180 x 40 x 22,0 x 18,0	253,31	268,13						

* Codolo Rinforzato: M12 - Ø 12 x 9
M14 - Ø 14 x 11
M16 - Ø 16 x 12



- Lubrificazione: **CUT MAGIC XTHICK**
- Si raccomanda di filettare il pezzo sulla stessa attrezzatura utilizzata per la foratura precedente e nella stessa posizione, per garantire co-assialità tra il maschio e il preforo.

Ref. ACXT00250

HRc	Vc (m/min)
48 Hrc	8 m/min
56 Hrc	6 m/min
62Hrc	3 m/min

MASCHI A MACCHINA QUALSIASI TERRENO
**QUALSIASI
TERRENO**

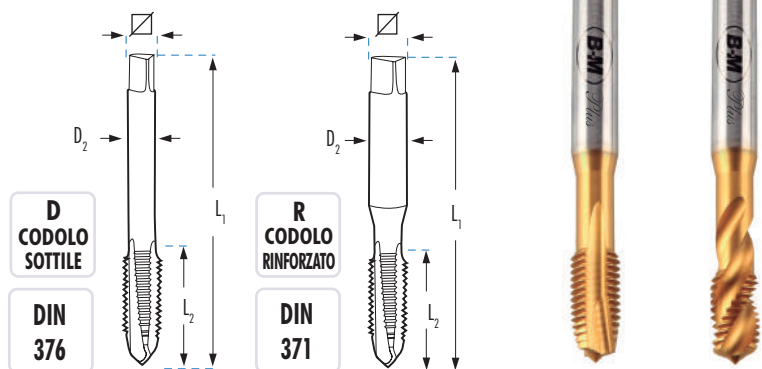
**HSSCo
5%**
TiN
**TOL
6H**
APPLICAZIONI
**1200
N/mm²**
Al
GHISA
Ti
INOX
**Vc
13
m/min**

		L1 x L2 x D2 x ∇ mm	M2RD	M4RD
			FORMA B €	35° €
M 3 x 0,50	2,50	R 56 x 11 x 3,5 x 2,7	21,91	26,79
M 4 x 0,70	3,30	R 63 x 13 x 4,5 x 3,4	23,22	26,79
M 5 x 0,80	4,20	R 70 x 16 x 6,0 x 4,9	26,91	30,60
M 6 x 1,00	5,00	R 80 x 17 x 6,0 x 4,9	27,83	31,75
M 8 x 1,25	6,80	R 90 x 20 x 8,0 x 6,2	32,61	36,24
M 10 x 1,50	8,50	R 100 x 22 x 10,0 x 8,0	37,63	42,90
CODOLO SOTTILE			M2DD	M4DD
M 12 x 1,75	10,20	D 110 x 24 x 9,0 x 7,0	47,42	56,44
M 14 x 2,00	12,00	D 110 x 26 x 11,0 x 9,0	61,92	68,05
M 16 x 2,00	14,00	D 110 x 27 x 12,0 x 9,0	69,38	75,10
M 18 x 2,50	15,50	D 125 x 30 x 14,0 x 11,0	94,67	111,18
M 20 x 2,50	17,50	D 140 x 32 x 16,0 x 12,0	110,43	114,59

MASCHI A MACCHINA PER LAVORAZIONI SPECIALI HSSCo

Al
GHISA
OTTONE

 DIN 13 60°
HSSCo 5%
MD
TOL 6H

Vc
18 m/min

Vc
11 m/min

Vc
21 m/min

Vc
16 m/min

Vc
19 m/min

Vc
19 m/min

D
CODOLO SOTTILE

DIN 376

R
CODOLO RINFORZATO

DIN 371

				M5R	M6R	M1RFM	MHM1R	M1RL	M1RLCRN
APPLICAZIONE		Al	Al	GHISA	GHISA	OTTONE	OTTONE	OTTONE	OTTONE
MATERIALE		HSSCo 5%	HSSCo 5%	HSSCo 5%	HSSCo 5%	MD	HSSCo 5%	HSSCo 5%	HSSCo 5%
FINITURA		BRILLANTE	BRILLANTE	OX	BRILLANTE	BRILLANTE	BRILLANTE	BRILLANTE	CrN
FORMA		DENTI ALTERNATI	2 CANALI	FORMA C	FORMA C	FORMA C	FORMA C	FORMA C	FORMA C
		L1 x L2 x D2 x ∇ mm		€	€	€	€	€	€
M 3x0,50	2,50	R	56 x 11 x 3,5 x 2,7	17,28	19,96	14,84	82,76	17,61	19,99
M 4x0,70	3,30	R	63 x 13 x 4,5 x 3,4	17,26	19,96	15,35	82,76	18,70	22,05
M 5x0,80	4,20	R	70 x 16 x 6,0 x 4,9	18,02	20,36	15,35	82,76	18,70	22,11
M 6x1,00	5,00	R	80 x 17 x 6,0 x 4,9	17,97	22,02	17,42	94,38	20,48	24,16
M 8x1,25	6,80	R	90 x 20 x 8,0 x 6,2	21,82	26,39	19,52	105,40	23,35	29,38
M 10x1,50	8,50	R	100 x 22 x 10,0 x 8,0	25,92	31,22	22,31	132,08	28,09	35,75
CODOLO SOTTILE				M5D	M6D	M1DFM	MHM1D	M1DL	M1DLCRN
M 12x1,75	10,20	D	110 x 24 x 9,0 x 7,0	33,19	40,36	28,60	187,77	33,40	44,00
M 14x2,00	12,00	D	110 x 26 x 11,0 x 9,0	42,87	51,09	47,00	292,55	41,00	53,64
M 16x2,00	14,00	D	110 x 27 x 12,0 x 9,0	47,64	66,87	55,31	348,04	47,17	59,98
M 18x2,50	15,50	D	125 x 30 x 14,0 x 11,0			77,37	426,63	61,89	75,97
M 20x2,50	17,50	D	140 x 32 x 16,0 x 12,0			77,66	516,62	69,46	84,58



- Lubrificazione: **CUT MAGIC ALUMINIO**
- Si raccomanda l'applicazione dell'olio da taglio CUT MAGIC ALUMINIO per ottimizzare il processo di filettatura in alluminio e le sue ghise.

Ref. ACAL00250

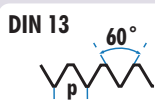
MASCHI PER FILETTARE A MACCHINA PER LAMINAZIONE

HSSCo
5%
HSSCo
8%
TOL
6HX
APPLICAZIONI

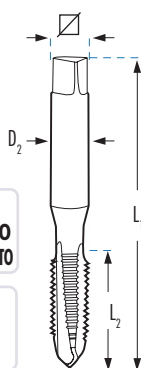
Al
GHISA

INOX
Plus
R
CODOLO
RINFORZATO
DIN
2174

				M07R	M07RT	M07RCR	M07RCCR	M09RCCR	M07RXTCR
		APPLICAZIONE		LAMINAZIONE	LAMINAZIONE	LAMINAZIONE	LAMINAZIONE	LAMINAZIONE	LAMINAZIONE
		MATERIALE		HSSCo 5%	HSSCo 5%	HSSCo 5%	HSSCo 5%	HSSCo 8%	HSSCo 5%
		FINITURA		OX	TiN	OX	TiCN	TiCN	TiN
		FORMA							
			L1 x L2 x D2 x mm	€	€	€	€	€	€
M	3x0,50	2,75	R 56 x 11 x 3,5 x 2,7	26,22	36,87	33,96	51,72	117,35	87,52
M	3,5x0,60	3,20	R 56 x 11 x 3,5 x 2,7	27,56	39,15	37,20	54,73		
M	4x0,70	3,65	R 63 x 13 x 4,5 x 3,4	28,70	38,46	33,61	53,94	118,83	87,52
M	5x0,80	4,60	R 70 x 16 x 6,0 x 4,9	28,70	38,46	35,99	53,94	120,41	94,45
M	6x1,00	5,50	R 80 x 17 x 6,0 x 4,9	29,32	40,64	36,63	57,00	122,33	94,45
M	8x1,25	7,40	R 90 x 20 x 8,0 x 6,2	35,32	53,63	42,72	75,24	135,69	113,03
M	10x1,50	9,30	R 100 x 22 x 10,0 x 8,0	41,46	60,14	50,36	82,82	162,02	138,00
		CODOLO SOTTILE		M07D	M07DT	M07DCR	M07DCCR	M09DCCR	M07DXTCR
M	12x1,75	11,20	D 110 x 24 x 9,0 x 7,0	50,88	75,74	59,34	105,64	191,78	179,71
M	14x2,00	13,05	D 110 x 26 x 11,0 x 9,0	91,75	124,22	98,97	169,37	238,67	258,51
M	16x2,00	15,05	D 110 x 27 x 12,0 x 9,0	107,72	139,90	116,18	198,74	328,27	262,99
M	18x2,50	16,80	D 125 x 30 x 14,0 x 11,0	131,01	161,08	141,31	211,83	388,95	
M	20x2,50	18,80	D 140 x 32 x 16,0 x 12,0	172,63	243,85	186,20	347,39	430,62	

MASCHI A MACCHINA HSSCO A TOLLERANZA SPECIALE E SOVRAMISURA



			M2R4H	M4R4H	M2R6G	M4R6G	M2R7G	M4R7G	M2R+0,1	M4R+0,1	M2R+0,2	M4R+0,2
TOLLERANZA			TOL 4H	TOL 4H	TOL 6G	TOL 6G	TOL 7G	TOL 7G	TOL 6H (+0,1)	TOL 6H (+0,1)	TOL 6H (+0,2)	TOL 6H (+0,2)
MATERIALE			HSSCo 5%	HSSCo 5%	HSSCo 5%	HSSCo 5%	HSSCo 5%	HSSCo 5%	HSSCo 5%	HSSCo 5%	HSSCo 5%	HSSCo 5%
FINITURA			BRILLANTE	BRILLANTE	BRILLANTE	BRILLANTE	BRILLANTE	BRILLANTE	BRILLANTE	BRILLANTE	BRILLANTE	BRILLANTE
FORMA			FORMA B	35°	FORMA B	35°	FORMA B	35°	FORMA B	35°	FORMA B	35°
L1 x L2 x D2 mm			€	€	€	€	€	€	€	€	€	€
M 3x0,50	2,50	R 56 x 11 x 3,5 x 2,7	20,51	25,37	14,48	17,66	17,42	21,54	17,19	21,81	26,50	32,81
M 4x0,70	3,30	R 63 x 13 x 4,5 x 3,4	20,98	25,37	14,48	17,66	17,82	21,54	17,19	21,81	27,11	28,95
M 5x0,80	4,20	R 70 x 16 x 6,0 x 4,9	20,98	24,31	15,23	18,43	17,82	20,63	17,19	20,90	27,11	31,43
M 6x1,00	5,00	R 80 x 17 x 6,0 x 4,9	23,06	26,68	15,17	18,55	19,59	22,64	17,25	22,92	29,80	34,48
M 8x1,00	7,00	D 90 x 20 x 6,0 x 4,9			35,83	39,64						
M 8x1,25	6,75	R 90 x 20 x 8,0 x 6,2	25,82	30,45	19,29	22,87	21,91	25,84	21,15	26,17	29,47	39,36
M 10x1,00	9,00	D 90 x 16 x 7,0 x 5,5			42,30	49,23						
M 10x1,50	8,50	R 100 x 22 x 10,0 x 8,0	31,74	36,13	22,87	26,18	26,95	34,08	26,01	31,03	36,24	41,20
CODOLO SOTTILE			M2D4H	M4D4H	M2D6G	M4D6G	M2D7G	M4D7G	M2D+0,1	M4D+0,1	M2D+0,2	M4D+0,2
M 12x1,50	10,50	D 100 x 22 x 9,0 x 7,0			74,85	88,74						
M 12x1,75	10,20	D 110 x 24 x 9,0 x 7,0	40,95	48,62	26,72	28,97	32,83	38,98	32,10	49,12	46,68	55,45
M 14x2,00	12,00	D 110 x 26 x 11,0 x 9,0			38,93	41,70			69,54	82,91	86,29	100,02
M 16x2,00	14,00	D 110 x 27 x 12,0 x 9,0			43,48	44,25			81,80	100,19	89,60	106,68
M 18x2,50	15,50	D 125 x 30 x 14,0 x 11,0			60,49	64,88			119,16	134,91	143,78	151,40
M 20x2,50	17,50	D 140 x 32 x 16,0 x 12,0			74,52	85,48			128,77	143,57	155,35	163,13

4H.-Per filettature molto precise. Regolazione più esatta.

6G.- Per filettature con rivestimenti. Spessore tra 20 – 40 μ

7G.-Per filettature con rivestimenti. Spessore tra 20 – 50 μ

6H. (+0,1)- Per ottenere filettature con sovramisure o per compensare deformazioni da trattamenti termici.

6H. (+0,2)- Per ottenere filettature con sovramisure o per compensare deformazioni da trattamenti termici.

MASCHI A MACCHINA EXTRA LUNGI HSSCo

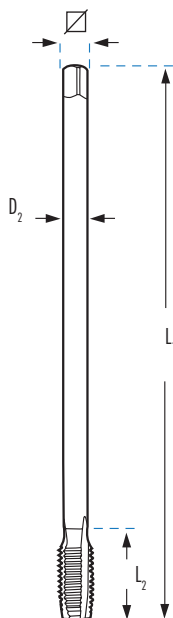
FORMA
BHSSCo
5%

BRILLANTE

TOL
6HR
CODOLO
RINFORZATODIN
371D
CODOLO
SOTTILEDIN
376

					M2L
				L1 x L2 x D2 x ∇ mm	FORMA B €
M2LM03X0,50	M 3x0,50	2,50	R	100 x 10 x 3,5 x 2,7	18,62
M2LM04X0,70	M 4x0,70	3,30	R	120 x 12 x 4,5 x 3,4	19,04
M2LM05X0,80	M 5x0,80	4,20	R	140 x 14 x 6,0 x 4,9	22,40
M2LM06X1,00-120	M 6x1,00	5,00	R	120 x 16 x 6,0 x 4,9	21,01
M2LM06X1,00	M 6x1,00	5,00	R	160 x 16 x 6,0 x 4,9	22,43
M2LM07X1,00	M 7x1,00	6,00	R	160 x 17 x 7,0 x 5,5	27,20
M2LM08X1,25-150	M 8x1,25	6,80	R	150 x 18 x 8,0 x 6,2	25,41
M2LM08X1,25	M 8x1,25	6,80	R	180 x 18 x 8,0 x 6,2	27,33

CODOLO SOTTILE

					M2L-D
				L1 x L2 x D2 x ∇ mm	FORMA B €
M2LM06X1,00D	M 6x1,00	5,00	D	160 x 16 x 4,5 x 3,4	24,89
M2LM08X1,25D	M 8x1,25	6,80	D	180 x 18 x 6,2 x 5,0	29,19
M2LM10X1,50-150	M 10x1,50	8,50	D	150 x 20 x 7,0 x 5,5	29,51
M2LM10X1,50	M 10x1,50	8,50	D	200 x 20 x 7,0 x 5,5	31,45
M2LM12X1,75-150	M 12x1,75	10,20	D	150 x 22 x 8,5 x 6,5	33,51
M2LM12X1,75	M 12x1,75	10,20	D	220 x 22 x 8,5 x 6,5	35,60
M2LM14X2,00	M 14x2,00	12,00	D	220 x 25 x 10,5 x 8,0	66,02
M2LM16X2,00	M 16x2,00	14,00	D	220 x 28 x 12,5 x 10,0	77,68
M2LM18X2,50	M 18x2,50	15,50	D	250 x 32 x 14,0 x 11,0	141,32
M2LM20X2,50	M 20x2,50	17,50	D	250 x 32 x 16,0 x 12,0	152,76
M2LM22X2,50	M 22x2,50	19,50	D	250 x 35 x 18,0 x 14,5	247,13
M2LM24X3,00	M 24x3,00	21,00	D	250 x 38 x 18,0 x 14,5	311,18

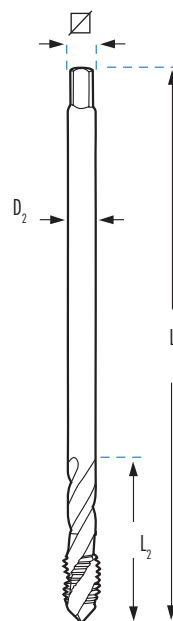
HSSCo
5%

BRILLANTE

TOL
6HR
CODOLO
RINFORZATODIN
371D
CODOLO
SOTTILEDIN
376

					M4L
				L1 x L2 x D2 x ∇ mm	FORMA B €
M4LM03X0,50	M 3x0,50	2,50	R	100 x 10 x 3,5 x 2,7	22,07
M4LM04X0,70	M 4x0,70	3,30	R	120 x 12 x 4,5 x 3,4	23,04
M4LM05X0,80	M 5x0,80	4,20	R	140 x 14 x 6,0 x 4,9	25,29
M4LM06X1,00-120	M 6x1,00	5,00	R	120 x 16 x 6,0 x 4,9	25,01
M4LM06X1,00	M 6x1,00	5,00	R	160 x 16 x 6,0 x 4,9	26,74
M4LM07X1,00	M 7x1,00	6,00	R	160 x 17 x 7,0 x 5,5	31,50
M4LM08X1,25-150	M 8x1,25	6,80	R	150 x 18 x 8,0 x 6,2	29,01
M4LM08X1,25	M 8x1,25	6,80	R	180 x 18 x 8,0 x 6,2	31,27

CODOLO SOTTILE

					M4L-D
				L1 x L2 x D2 x ∇ mm	FORMA B €
M4LM06X1,00D	M 6x1,00	5,00	D	160 x 16 x 4,5 x 3,4	28,82
M4LM08X1,25D	M 8x1,25	6,80	D	180 x 18 x 6,2 x 5,0	33,73
M4LM10X1,50-150	M 10x1,50	8,50	D	150 x 20 x 7,0 x 5,5	35,85
M4LM10X1,50	M 10x1,50	8,50	D	200 x 20 x 7,0 x 5,5	38,01
M4LM12X1,75-150	M 12x1,75	10,20	D	150 x 22 x 8,5 x 6,5	37,11
M4LM12X1,75	M 12x1,75	10,20	D	220 x 22 x 8,5 x 6,5	39,51
M4LM14X2,00	M 14x2,00	12,00	D	220 x 25 x 10,5 x 8,0	73,99
M4LM16X2,00	M 16x2,00	14,00	D	220 x 28 x 12,5 x 10,0	107,23
M4LM18X2,50	M 18x2,50	15,50	D	250 x 32 x 14,0 x 11,0	160,03
M4LM20X2,50	M 20x2,50	17,50	D	250 x 32 x 16,0 x 12,0	170,30
M4LM22X2,50	M 22x2,50	19,50	D	250 x 35 x 18,0 x 14,5	278,63
M4LM24X3,00	M 24x3,00	21,00	D	250 x 38 x 18,0 x 14,5	326,81

MASCHIO A MACCHINA PER DADI FILETTATURA METRICA DIN 357



HSSCo
5%

BRILLANTE

TOL
6H

DIN
357



				MTU	
				FORMA A	
				€	
			L1 x L2 x D2 x ∇ mm		
M	3x0,50**	2,50	D 70 x 22 x 2,2	24,00	
M	4x0,70	3,30	D 90 x 25 x 2,8 x 2,1	24,00	
M	5x0,80	4,20	D 100 x 28 x 3,5 x 2,7	24,00	
M	6x1,00	5,00	D 110 x 32 x 4,5 x 3,4	24,00	
M	8x1,25	6,80	D 125 x 40 x 6,0 x 4,9	29,27	
M	10x1,50	8,50	D 140 x 45 x 7,0 x 5,5	31,50	
M	12x1,75	10,20	D 180 x 50 x 9,0 x 7,0	51,73	
M	14x2,00	12,00	D 200 x 56 x 11,0 x 9,0	60,26	
M	16x2,00	14,00	D 200 x 63 x 12,0 x 9,0	74,62	
M	18x2,50	15,50	D 220 x 63 x 14,0 x 11,0	100,39	
M	20x2,50	17,50	D 250 x 70 x 16,0 x 12,0	127,26*	
M	22x2,50	19,50	D 280 x 80 x 18,0 x 14,5	156,14*	
M	24x3,00	21,00	D 280 x 80 x 18,0 x 14,5	212,43*	

** Codolo cilindrico

*Fino ad esaurimento scorte

MASCHIO A MACCHINA PER FILETTATURA TRAPEZOIDALE HSS

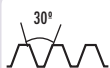

HSS

BRILLANTE



DIN
103

TOL
7H

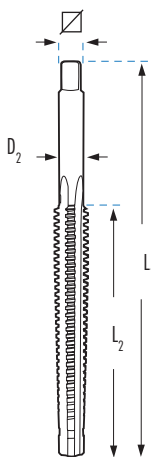

				MRTM	
				€	
			L1 x L2 x D2 x ∇ mm		
Tr	14 x 3	11,25	160 x 105 x 10,5 x 8,0	399,63	
Tr	16 x 4	12,25	205 x 110 x 11,5 x 9,0	434,12	
Tr	18 x 4	14,25	215 x 120 x 13,0 x 10,0	444,94	
Tr	20 x 4	16,25	230 x 130 x 15,0 x 12,0	466,17	
Tr	22 x 5	17,25	270 x 165 x 16,0 x 12,0	605,21	
Tr	24 x 5	19,25	280 x 165 x 18,0 x 14,5	696,01	
Tr	26 x 5	21,25	290 x 170 x 20,0 x 16,0	720,14	
Tr	28 x 5	23,25	300 x 180 x 22,0 x 18,0	804,59	
Tr	30 x 6	24,25	345 x 200 x 23,0 x 18,0	951,69	

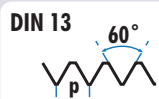
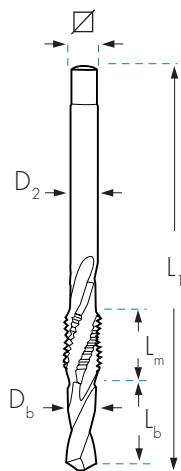
PUNTA-MASCHIO HSSCo

HSSCo
5%
BRILLANTE
TOL
6H
R
CODOLO
RINFORZATO
DIN
371
D
CODOLO
SOTTILE
DIN
376

								M8M	
		Lb mm	Lm mm	L1 mm	Db mm	D2 mm		€	
M	3x0,50	R	9,0	12,5	62,0	2,5	3,5	2,7	32,50
M	4x0,70	R	10,0	16,0	66,0	3,30	4,5	3,4	32,50
M	5x0,80	R	12,5	18,0	75,5	4,20	6,0	4,9	35,07
M	6x1,00	R	14,0	20,0	81,0	5,00	6,0	4,9	38,75
M	8x1,00	R	20,0	14,0	91,0	7,00	6,0	4,9	48,74
M	8x1,25	R	20,0	14,0	91,0	6,75	8,0	6,2	50,25

CODOLO SOTTILE

M	8x1,25	D	20,0	14,0	91,0	6,75	6,0	4,9	45,13
M	10x1,00	D	20,0	15,0	95,0	9,00	7,0	5,5	60,52
M	10x1,50	D	25,0	18,0	105,0	8,50	7,0	5,5	49,32
M	12x1,50	D	24,0	18,0	110,0	10,50	9,0	7,0	65,51
M	12x1,75	D	28,0	20,0	118,0	12,50	11,0	9,0	58,59
M	14x1,50	D	28,0	20,0	118,0	12,50	11,0	9,0	110,93
M	14x2,00	D	28,0	22,0	130,0	12,00	11,0	9,0	107,22
M	16x2,00	D	36,0	24,0	139,0	14,00	12,0	9,0	173,63
M	18x2,50	D	40,0	26,0	151,0	15,50	14,0	11,0	205,65
M	20x2,50	D	45,0	30,0	168,0	17,50	16,0	2,0	347,59

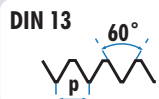
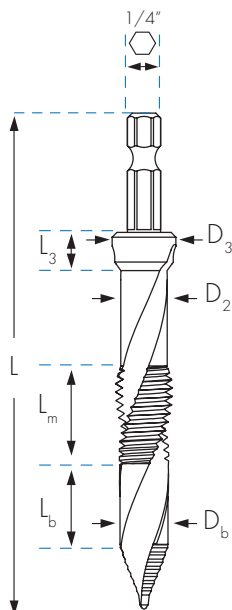
NOTA: Non utilizzare i Punta-Maschi in fori ciechi o passanti più profondi di Lb.

PUNTA MASCHIO SVASATRICE HSSCo STEP CUT
NEW

HSSCo
5%
BRILLANTE
TOL
6H
D
CODOLO
SOTTILE
1/4"
STEP CUT

									MTKM		
		Lb mm	Lm mm	L3 mm	L mm	Db mm	D2 mm	D3 mm		€	
M	3x0,50	D	7,0	6,0	6,0	57,0	2,5	2,2	7,3	1/4"	23,41
M	4x0,70	D	7,0	8,5	6,0	62,0	3,3	3,0	7,3	1/4"	23,41
M	5x0,80	D	9,0	10,0	6,0	69,0	4,2	3,7	7,3	1/4"	23,41
M	6x1,00	D	10,0	12,0	6,0	73,0	5,0	4,5	7,3	1/4"	23,41
M	8x1,25	D	12,0	16,0	6,0	87,0	6,8	6,3	9,4	1/4"	32,39
M	10x1,50	D	14,0	20,0	6,0	96,0	8,5	8,0	11,4	1/4"	39,05
M	12x1,75	D	16,0	24,0	8,0	112,0	10,3	9,8	13,4	1/4"	56,36

NOTA: Non utilizzare i Punta-Maschio Svasatrice in fori ciechi o passanti più profondi di Lb.

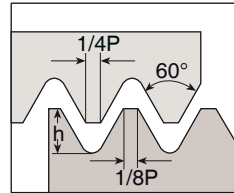
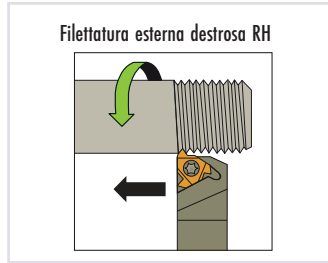
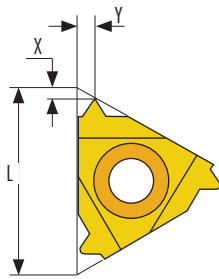
PLACCHETTE PER FILETTATURA ESTERNA



Norma: R262 (DIN 13)
Tolleranza classe: 6g/6H

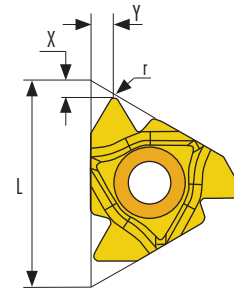

Profilo totale

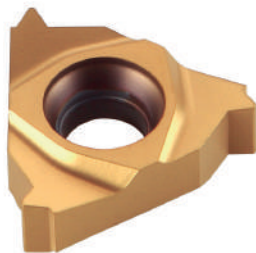
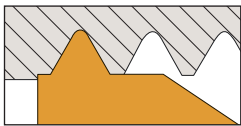

Profilo parziale

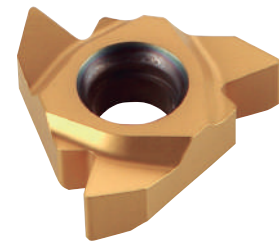
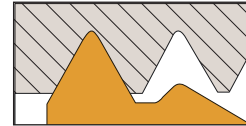

Filettare il profilo completo, terminando il diametro esterno della filettatura. Utilizzeremo una placchetta differente per ogni passo.

Non terminare il diametro esterno della filettatura.

La stessa placchetta può essere utilizzata per una gamma di differenti passi aventi lo stesso angolo di filettatura.

PROFILO TOTALE 60°

FILETTATURA ESTERNA	L	PASSO	h	X	Y	€
PRE-16-075	16	0,75	0,46	0,6	0,6	26,94*
PRE-16-100		1,00	0,61	0,7	0,7	26,94*
PRE-16-125		1,25	0,77	0,8	0,9	26,94*
PRE-16-150		1,50	0,92	0,8	1	26,94*
PRE-16-175		1,75	1,07	0,9	1,2	26,94*
PRE-16-200		2,00	1,23	1	1,3	26,94*
PRE-16-250		2,50	1,53	1,1	1,5	26,94*
PRE-16-300		3,00	1,84	1,2	1,6	26,94*

*Fino ad esaurimento scorte.

PROFILO PARZIALE 60°

FILETTATURA ESTERNA	L	INTERVALLI METRICI	INTERVALLI POLLICI	r	X	Y	€
PPRE-16-150	16	0,50-1,50	48 - 16	0,05	0,80	0,90	26,94*

*Fino ad esaurimento scorte.

PORTAUTENSILI DA FILETTATURA ESTERNA

FILETTATURA ESTERNA	H1=H=B=F	L1	L2	€
PEXT-25-16	25	153	30	197,03*

*Fino ad esaurimento scorte.

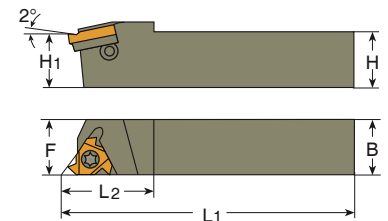

FORMULA MATEMATICA PER RICAVARE LA VELOCITÀ DI GIRO DEL PEZZO (RPM)

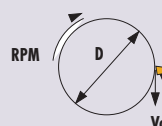

$$RPM = \frac{1000 \times Vc}{\pi \times D}$$

RPM: Rotazioni x minuto

Vc: Velocità di taglio (m/mm)

D: Diametro pezzo (mm)

le RPM si ricavano in funzione di Vc e D

	Vc		Vc
ACCIAIO DOLCE 70 kg/mm ²	25 m / min	ALLUMINIO	50 m / min
ACCIAIO TRATTATO 120 kg/mm ²	13 m / min	TITANIO	18 m / min
INOX	11 m / min	GHISA	25 m / min
		OTTONE	50 m / min

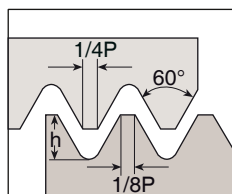
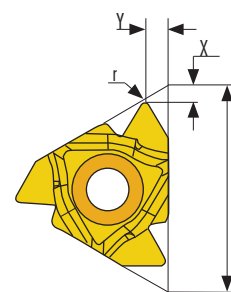
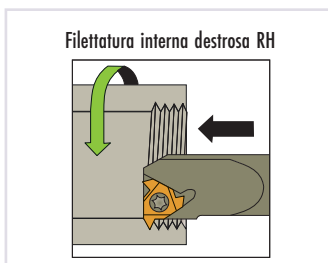
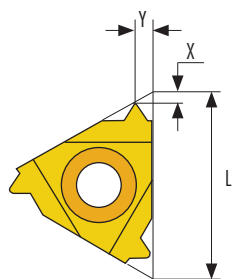
PLACCHETTE PER FILETTATURA INTERNA

Norma: R262 (DIN 13)
 Tolleranza classe: 6g/6H

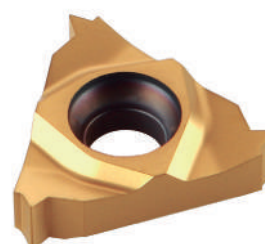
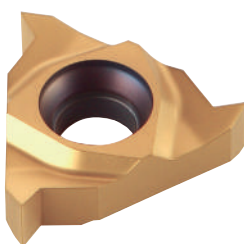
PROFILO TOTALE 60°

FILETTATURA INTERNA	L	PASSO	h	X	Y	€
PRI-16-075	16	0,75	0,43	0,6	0,6	26,94*
PRI-16-100		1,00	0,58	0,6	0,7	26,94*
PRI-16-125		1,25	0,72	0,8	0,9	26,94*
PRI-16-150		1,50	0,87	0,8	1,0	26,94*
PRI-16-175		1,75	1,01	0,9	1,2	26,94*
PRI-16-200		2,00	1,15	1,0	1,3	26,94*
PRI-16-250		2,50	1,44	1,1	1,5	26,94*
PRI-16-300		3,00	1,73	1,1	1,5	26,94*

*Fino ad esaurimento scorte.

PROFILO PARZIALE 60°

FILETTATURA INTERNA	L	INTERVALLI METRICI	INTERVALLO POLLICI	r	X	Y	€
PPRI-16-150	16	0,50-1,50	48 - 16	0,05	0,80	0,90	26,94*
PPRI-16-300		1,75-3,00	14 - 8	0,16	1,20	1,70	26,94*

*Fino ad esaurimento scorte.

PORTAUTENSILI DA FILETTATURA INTERNA

FILETTATURA INTERNA	L	L1	D	D1	A	Ø MIN. FORO	€
PINT-25-16	200	45	25	24,6	22,6	29	237,45*

*Fino ad esaurimento scorte.

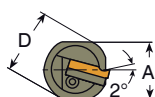
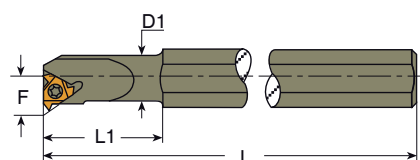

SET DI MASCHI A MACCHINA HSSCo IN SCATOLE METALLICHE

**USO
GENERALE**

**HSSCo
5%**



Ref. JM6



Ref. JM2





Ref. JM8



Ref. JM4

CONTENUTO

	FORMA C	FORMA B	 15°	 35°	 HSS	HSSCo 5% €
JM5	M3 - M4 - M5 - M6 M8 - M10 - M12	-	-	-	-	113,22
JM1	M3 - M4 - M5 - M6 M8 - M10 - M12	-	-	-	2.5/3.3/4.2/5.0/6.8/8.5/10.2 mm	139,26
JM6	-	M3 - M4 - M5 - M6 M8 - M10 - M12	-	-	-	119,97
JM2	-	M3 - M4 - M5 - M6 M8 - M10 - M12	-	-	2.5/3.3/4.2/5.0/6.8/8.5/10.2 mm	146,00
JM7	-	-	M3 - M4 - M5 - M6 M8 - M10 - M12	-	-	153,92
JM3	-	-	M3 - M4 - M5 - M6 M8 - M10 - M12	-	2.5/3.3/4.2/5.0/6.8/8.5/10.2 mm	179,96
JM8	-	-	-	M3 - M4 - M5 - M6 M8 - M10 - M12	-	141,82
JM4	-	-	-	M3 - M4 - M5 - M6 M8 - M10 - M12	2.5/3.3/4.2/5.0/6.8/8.5/10.2 mm	167,86



ASSORTIMENTI DI MASCHI A MACCHINA IN SCATOLE METALLICHE

Plus





Ref. JMPT2

CONTENUTO

	FORMA B	BRILLANTE	 35°	BRILLANTE	 HSSCo 5%	HSS PM €		TiN €
JMP6	M3 - M4 - M5 - M6 M8 - M10 - M12		-		-	135,78	JMPT6	196,64
JMP2	M3 - M4 - M5 - M6 M8 - M10 - M12		-		2.5/3.3/4.2/5.0/6.8/8.5/10.2 mm	183,80	JMPT2	244,66
JMP8	-		M3 - M4 - M5 - M6 M8 - M10 - M12		-	157,86	JMPT8	215,51
JMP4	-		M3 - M4 - M5 - M6 M8 - M10 - M12		2.5/3.3/4.2/5.0/6.8/8.5/10.2 mm	205,87	JMPT4	263,53

INOX



CONTENUTO

	FORMA B	OX	 35°	OX	 HSSCo 5%	HSS PM €		TiN €
JMX6	M3 - M4 - M5 - M6 M8 - M10 - M12		-		-	152,95	JMXT6	186,12
JMX2	M3 - M4 - M5 - M6 M8 - M10 - M12		-		2.5/3.3/4.2/5.0/6.8/8.5/10.2 mm	200,96	JMXT2	234,14
JMX8	-		M3 - M4 - M5 - M6 M8 - M10 - M12		-	187,01	JMXT8	215,67
JMX4	-		M3 - M4 - M5 - M6 M8 - M10 - M12		2.5/3.3/4.2/5.0/6.8/8.5/10.2 mm	235,03	JMXT4	263,68



1200
N/mm²

CONTENUTO

	FORMA B	OX	 35°	OX	 HSSCo 5%	HSS V3 €		TINALOX €
JMMD6	M3 - M4 - M5 - M6 M8 - M10 - M12		-		-	170,08	JMMDT6	243,27
JMMD2	M3 - M4 - M5 - M6 M8 - M10 - M12		-		2.5/3.3/4.2/5.0/6.8/8.5/10.2 mm	218,10	JMMDT2	291,29
JMMD8	-		M3 - M4 - M5 - M6 M8 - M10 - M12		-	186,61	JMMDT8	278,66
JMMD4	-		M3 - M4 - M5 - M6 M8 - M10 - M12		2.5/3.3/4.2/5.0/6.8/8.5/10.2 mm	234,63	JMMDT4	326,69

ASSORTIMENTI DI MASCHI A MACCHINA IN SCATOLE METALLICHE

1400
N/mm²



Ref. JMC2

CONTENUTO

	FORMA B	TiCN	15° TiCN	HSSCo 5%	HSS-PM €
JMC6	M3 - M4 - M5 - M6 - M8 - M10 - M12	-	-	-	278,89
JMC2	M3 - M4 - M5 - M6 - M8 - M10 - M12	-	-	2.5/3.3/4.2/5.0/6.8/8.5/10.2 mm	326,91
JMC8	-	M3 - M4 - M5 - M6 - M8 - M10 - M12	-	-	314,79
JMC4	-	M3 - M4 - M5 - M6 - M8 - M10 - M12	2.5/3.3/4.2/5.0/6.8/8.5/10.2 mm	-	362,82

QUALSIASI TERRENO

CONTENUTO

	FORMA B	TiN	35° TiN	HSSCo 5%	HSSCo 5% €
JMD6	M3 - M4 - M5 - M6 - M8 - M10 - M12	-	-	-	230,93
JMD2	M3 - M4 - M5 - M6 - M8 - M10 - M12	-	-	2.5/3.3/4.2/5.0/6.8/8.5/10.2 mm	278,93
JMD8	-	M3 - M4 - M5 - M6 - M8 - M10 - M12	-	-	263,58
JMD4	-	M3 - M4 - M5 - M6 - M8 - M10 - M12	2.5/3.3/4.2/5.0/6.8/8.5/10.2 mm	-	311,61

AI

CONTENUTO

	DENTI ALTERNATI	BRILLANTE	2 CANALI	BRILLANTE	HSS	HSSCo 5% €
JMAL6	M3 - M4 - M5 - M6 - M8 - M10 - M12	-	-	-	-	162,92
JMAL2	M3 - M4 - M5 - M6 - M8 - M10 - M12	-	-	-	2.5/3.3/4.2/5.0/6.8/8.5/10.2 mm	189,68
JMAL8	-	M3 - M4 - M5 - M6 - M8 - M10 - M12	-	-	-	191,59
JMAL4	-	M3 - M4 - M5 - M6 - M8 - M10 - M12	2.5/3.3/4.2/5.0/6.8/8.5/10.2 mm	-	-	217,64

MASCHI A MACCHINA IN ASTUCCI
**USO
GENERALE**
CONTENUTO

	FORMA B	BRILLANTE	 35°	BRILLANTE	HSSCo 5% €
PT01	M4 - M5 - M6 - M8 - M10	M4 - M5 - M6 - M8 - M10	M4 - M5 - M6 - M8 - M10	M4 - M5 - M6 - M8 - M10	154,07



Ref. PT01

Plus
CONTENUTO

	FORMA B	BRILLANTE	 35°	BRILLANTE	HSS PM €	TiN €
PT02	M4 - M5 - M6 - M8 - M10	M4 - M5 - M6 - M8 - M10	M4 - M5 - M6 - M8 - M10	M4 - M5 - M6 - M8 - M10	169,53	PT03 248,92



Ref. PT03

INOX
CONTENUTO

	FORMA B	OX	 35°	OX	HSS PM €	TiN €
PT05	M4 - M5 - M6 - M8 - M10	M4 - M5 - M6 - M8 - M10	M4 - M5 - M6 - M8 - M10	M4 - M5 - M6 - M8 - M10	197,15	PT13 237,02

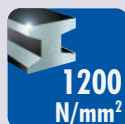

Ref. PT05

**1200
N/mm²**
CONTENUTO

	FORMA B	OX	 35°	OX	HSS V3 €	TINALOX €
PT04	M4 - M5 - M6 - M8 - M10	M4 - M5 - M6 - M8 - M10	M4 - M5 - M6 - M8 - M10	M4 - M5 - M6 - M8 - M10	209,19	PT14 313,56



Ref. PT04

**1400
N/mm²**
CONTENUTO

	FORMA B	TiCN	 15°	TiCN	HSS PM €
PT11	M4 - M5 - M6 - M8 - M10	M4 - M5 - M6 - M8 - M10	M4 - M5 - M6 - M8 - M10	M4 - M5 - M6 - M8 - M10	361,60



Ref. PT11

MASCHI A MACCHINA IN ASTUCCI

AI



Ref. PT06

CONTENUTO

	DENTI ALTERN.	2 CANALI	HSSCo 5% €
PT06	M4 - M5 - M6 M8 - M10	M4 - M5 - M6 M8 - M10	209,87

GHISA



Ref. PT07

CONTENUTO

	FORMA C	HSSCo 5% €
PT07	M4 - M5 - M6 - M8 - M10 M4 - M5 - M6 - M8 - M10	170,90

OTTONE



Ref. PT10

CONTENUTO

	FORMA C	HSSCo 5% €
PT10	M4 - M5 - M6 - M8 - M10 M4 - M5 - M6 - M8 - M10	207,73



LAMINAZIONE



Ref. PT08

CONTENUTO

		HSSCo 5% €
PT08	M4 - M5 - M6 - M8 - M10 M4 - M5 - M6 - M8 - M10	347,00



Ref. PT09

CONTENUTO

		HSSCo 5% €
PT09	M4 - M5 - M6 - M8 - M10 M4 - M5 - M6 - M8 - M10	384,99

TOL 6G



Ref. PT12

CONTENUTO

	FORMA B	 35°	HSSCo 5% €
PT12	M4 - M5 - M6 M8 - M10	M4 - M5 - M6 M8 - M10	186,32

ESPOSITORI IN METACRILATO PER MASCHI A MACCHINA
ESPOSITORE IN METACRILATO

MM-03

Composizione: Maschi a macchina, Serie Normale

HSSCo
5%

Ref. MM-03

FORMA
B

Fori passanti, Ref. M2

M4	M5	M6	M8	M10	M12	M14
5	10	10	10	10	5	4



35°

Fori ciechi, Ref. M4

M4	M5	M6	M8	M10	M12	M14
5	10	10	10	10	5	4

Dimensioni: larghezza 240 x profondità 240 x altezza 245 mm

2.016,85 €



Ref. MM-04

ESPOSITORE IN METACRILATO

MM-04

Composizione: Maschi a macchina, Serie Plus
Fabbricati in acciaio sinterizzato PM
HSS
PM
Plus
FORMA
B

Fori passanti, Ref. M2

M4	M5	M6	M8	M10	M12	M14
5	10	10	10	10	5	4



35°

Fori ciechi, Ref. M4

M4	M5	M6	M8	M10	M12	M14
5	10	10	10	10	5	4

Dimensioni: larghezza 240 x profondità 240 x altezza 245 mm

2.322,55 €

ESPOSITORE IN METACRILATO

MM-05

Composizione: Maschi a macchina per lavorazioni speciali

FORMA
B

Fori passanti Ref. M2



35°

Fori ciechi, Ref. M4

1200
N/mm²

M4	M5	M6	M8	M10	M12	M14
1	2	2	2	2	1	1

1200
N/mm²

M4	M5	M6	M8	M10	M12	M14
1	2	2	2	2	1	1



INOX

M4	M5	M6	M8	M10	M12	M14
1	2	2	2	2	1	1



INOX

M4	M5	M6	M8	M10	M12	M14
1	2	2	2	2	1	1



AI

M4	M5	M6	M8	M10	M12	M14
1	2	2	2	2	1	1



AI

M4	M5	M6	M8	M10	M12	M14
1	2	2	2	2	1	1



TiN

M4	M5	M6	M8	M10	M12	M14
1	2	2	2	2	1	1



TiN

M4	M5	M6	M8	M10	M12	M14
1	2	2	2	2	1	1

1400
N/mm²

M4	M5	M6	M8	M10	M12
1	2	2	2	2	1

1400
N/mm²

M4	M5	M6	M8	M10	M12
1	2	2	2	2	1

Dimensioni: larghezza 240 x profondità 240 x altezza 245 mm

3.097,38 €