

# MACHOS Y TERRAJAS



**BLUE-MASTER<sup>®</sup>**  
*by celesa*

CUTTING TECHNOLOGIES

## JUEGOS DE MACHOS Y TERRAJAS PARA ROSCAR A MANO HSS

M  
MF



DIN 13 60°

Ref. M0

HSS

DIN 352

DIN 2181

TOL 6H

Ref. C5



HSS

DIN 223

TOL 6g

Para materiales hasta 38 HRc



				M0		C5	
	Uds.		L1 x L2 x mm	€	Ø x L3 mm	€	€
M 5,5x0,90	3	4,60	50 x 16 x 4,9	92,91	25 x 9	104,63	
M 6x0,50	2	5,50	50 x 14 x 4,9	31,55	20 x 5	40,48	
M 6x0,75	2	5,25	50 x 14 x 4,9	26,63	25 x 9	33,20	
<b>M 6x1,00</b>	<b>3</b>	<b>5,00</b>	50 x 19 x 4,9	23,58*	25 x 9	29,54*	
M 6x1,25	3	4,75	50 x 19 x 4,9	152,44	25 x 9	107,13	
M 7x0,75	2	6,25	50 x 14 x 4,9	34,96	25 x 9	32,87	
<b>M 7x1,00</b>	<b>3</b>	<b>6,00</b>	50 x 19 x 4,9	28,73*	25 x 9	31,01*	
M 7x1,25	3	5,75	50 x 19 x 4,9	105,92	25 x 9	128,76	
M 8x0,50	2	7,50	50 x 16 x 4,9	55,65	25 x 9	49,08	
M 8x0,75	2	7,25	50 x 16 x 4,9	36,63	25 x 9	35,54	
M 8x1,00	2	7,00	56 x 18 x 4,9	26,50*	25 x 9	34,27*	
<b>M 8x1,25</b>	<b>3</b>	<b>6,80</b>	56 x 22 x 4,9	28,70*	25 x 9	31,34*	
M 8x1,50	3	6,50	56 x 22 x 4,9	103,02	25 x 9	111,94	
M 9x1,00	2	8,00	63 x 18 x 5,5	38,81	25 x 9	38,09	
<b>M 9x1,25</b>	<b>3</b>	<b>7,80</b>	63 x 22 x 5,5	47,02*	25 x 9	36,43*	
M 10x0,50	2	9,50	63 x 18 x 5,5	57,38	30 x 10	123,69	
M 10x0,75	2	9,25	63 x 18 x 5,5	58,67	30 x 11	60,81	
M 10x1,00	2	9,00	63 x 18 x 5,5	28,38	38 x 10	40,32	
M 10x1,25	2	8,80	70 x 24 x 5,5	28,77	38 x 10	43,01	
<b>M 10x1,50</b>	<b>3</b>	<b>8,50</b>	70 x 24 x 5,5	35,39*	38 x 10	41,95*	
M 11x0,75	2	10,25	63 x 18 x 6,2	86,15	30 x 11	133,63	
M 11x1,00	2	10,00	63 x 18 x 6,2	54,27	30 x 11	63,64	
M 11x1,25	2	9,75	63 x 20 x 6,2	54,27	30 x 11	63,63	
<b>M 11x1,50</b>	<b>3</b>	<b>9,50</b>	70 x 24 x 6,2	58,99	38 x 10	50,83	
M 12x0,75	2	11,25	70 x 20 x 7,0	78,33	38 x 10	69,00	
M 12x1,00	2	11,00	70 x 20 x 7,0	50,32	38 x 10	60,81	
M 12x1,25	2	10,75	70 x 20 x 7,0	50,17	38 x 10	58,63	
M 12x1,50	2	10,50	70 x 20 x 7,0	42,75*	38 x 10	52,58*	
<b>M 12x1,75</b>	<b>3</b>	<b>10,20</b>	75 x 29 x 7,0	49,79*	38 x 14	45,58*	
M 13x0,75	2	12,25	70 x 20 x 9,0	88,52	38 x 10	121,66	
M 13x1,00	2	12,00	70 x 20 x 9,0	85,22	38 x 10	64,61	
M 13x1,25	2	11,75	70 x 20 x 9,0	77,80	38 x 10	86,39	
M 13x1,50	2	11,50	70 x 20 x 9,0	77,80	38 x 10	67,91	
<b>M 13x1,75</b>	<b>3</b>	<b>11,25</b>	70 x 20 x 9,0	90,02	38 x 14	72,77	
M 14x0,75	2	13,25	70 x 20 x 9,0	101,73	38 x 10	114,07	
M 14x1,00	2	13,00	70 x 20 x 9,0	78,43	38 x 10	68,20	
M 14x1,25	2	12,80	70 x 20 x 9,0	61,26*	38 x 10	68,20*	
M 14x1,50	2	12,50	70 x 20 x 9,0	47,64	38 x 10	58,06	
M 14x1,75	2	12,25	70 x 20 x 9,0	95,27	38 x 14	194,25	
<b>M 14x2,00</b>	<b>3</b>	<b>12,00</b>	80 x 30 x 9,0	55,08*	38 x 14	45,13*	
M 15x1,00	2	14,00	70 x 20 x 9,0	109,88	45 x 14	73,44	
M 15x1,25	2	13,75	70 x 20 x 9,0	113,85	45 x 14	113,77	
M 15x1,50	2	13,50	70 x 20 x 9,0	101,93	45 x 14	78,68	
<b>M 15x2,00</b>	<b>3</b>	<b>13,00</b>	80 x 30 x 9,0	110,13	45 x 14	98,62	
M 16x1,00	2	15,00	70 x 20 x 9,0	104,04	45 x 14	83,15	
M 16x1,25	2	14,75	70 x 20 x 9,0	109,51	45 x 14	69,96	
M 16x1,50	2	14,50	70 x 20 x 9,0	59,28*	45 x 14	65,31*	
<b>M 16x2,00</b>	<b>3</b>	<b>14,00</b>	80 x 32 x 9,0	78,81*	45 x 18	61,19*	
M 17x1,00	2	16,00	70 x 20 x 9,0	168,03	45 x 14	118,99	
M 17x1,25	2	15,75	70 x 20 x 9,0	168,03	45 x 14	118,99	
<b>M 17x1,50</b>	<b>2</b>	<b>15,50</b>	70 x 20 x 9,0	168,03	45 x 14	118,99	
M 17x1,75	2	15,25	70 x 20 x 9,0	115,67	45 x 14	87,92	
M 18x1,00	2	17,00	80 x 22 x 11,0	115,67	45 x 14	87,92	
M 18x1,25	2	16,75	80 x 22 x 11,0	165,12	45 x 14	91,45	

\* Consulte el precio de machos y terrajas a izquierdas disponibles en Pag.188

\* Recargo por cojinetes abiertos 20% sobre los precios tarifados

JUEGOS DE MACHOS Y TERRAJAS PARA ROSCAR A MANO HSS

DIN 13

60°

Ref. M0

HSS

DIN 352

DIN 2181

TOL 6H

Ref. C5

HSS

DIN 223

TOL 6g

		M0					C5						
		Uds.	Ø	L1 x L2 x L3 mm	€	Ø x L3 mm	€	Uds.	Ø	L1 x L2 x L3 mm	€	Ø x L3 mm	€
M 18x1,50	2	16,50	80 x 22 x 11,0	78,10	45 x 14	79,10	M 33x3,50	3	29,5	125 x 50 x 20,0	378,72*	65 x 25	140,34*
M 18x2,00	2	16,00	80 x 22 x 11,0	124,66*	45 x 14	88,38*	M 34x1,50	2	32,5	100 x 25 x 22,0	389,17	65 x 18	160,62
<b>M 18x2,50</b>	<b>3</b>	<b>15,50</b>	95 x 40 x 11,0	104,01*	45 x 18	61,22*	M 34x2,00	2	32,0	100 x 25 x 22,0	465,42	65 x 18	366,63
M 19x1,00	2	18,00	80 x 22 x 11,0	243,86	45 x 14	147,58	M 35x1,50	2	33,5	100 x 25 x 22,0	415,50	65 x 18	166,60
M 19x1,25	2	17,75	80 x 22 x 11,0	243,86	45 x 14	166,91	M 35x2,00	2	33,0	100 x 25 x 22,0	465,42	65 x 18	285,90
M 19x1,50	2	17,50	80 x 22 x 11,0	243,86	45 x 14	147,58	M 36x1,50	2	34,5	100 x 25 x 22,0	405,66	65 x 18	157,71
M 19x2,00	2	17,00	80 x 22 x 11,0	289,49	45 x 14	168,60	M 36x2,00	2	34,0	125 x 33 x 22,0	534,30	65 x 18	164,49
M 20x1,00	2	19,00	80 x 22 x 12,0	157,47	45 x 14	87,92	M 36x3,00	2	33,0	125 x 33 x 22,0	692,36*	65 x 25	165,03*
M 20x1,25	2	18,75	80 x 22 x 12,0	242,97	45 x 14	190,82	<b>M 36x4,00</b>	<b>3</b>	<b>32,0</b>	150 x 53 x 22,0	487,58*	65 x 25	143,08*
M 20x1,50	2	18,50	80 x 22 x 12,0	97,81	45 x 14	80,93	M 38x1,50	2	36,5	100 x 25 x 22,0	468,86	75 x 20	240,97
M 20x2,00	2	18,00	80 x 22 x 12,0	132,04*	45 x 14	87,92*	M 38x2,00	2	36,0	125 x 25 x 22,0	631,04	75 x 20	356,06
<b>M 20x2,50</b>	<b>3</b>	<b>17,50</b>	95 x 40 x 12,0	116,68*	45 x 18	60,26*	M 39x1,50	2	37,5	110 x 25 x 24,0	620,57	75 x 20	239,69
M 21x1,00	2	20,00	80 x 22 x 12,0	312,44	45 x 14	180,80	M 39x2,00	2	37,0	125 x 23 x 24,0	620,57	75 x 20	253,12
M 21x1,25	2	19,75	80 x 22 x 12,0	312,44	45 x 14	180,80	M 39x3,00	2	36,0	125 x 33 x 24,0	598,60*	75 x 30	258,53*
M 21x1,50	2	19,50	80 x 22 x 12,0	243,22	45 x 14	191,12	<b>M 39x4,00</b>	<b>3</b>	<b>35,0</b>	150 x 53 x 24,0	545,57*	75 x 30	217,63*
M 22x1,00	2	21,00	80 x 22 x 14,5	176,48	55 x 16	118,35	M 40x1,50	2	38,5	110 x 25 x 24,0	550,60	75 x 20	251,78
M 22x1,25	2	20,75	80 x 22 x 14,5	240,63	55 x 16	192,87	M 40x2,00	2	38,0	125 x 33 x 24,0	606,32	75 x 20	233,80
M 22x1,50	2	20,50	80 x 22 x 14,5	107,57	55 x 16	101,81	M 40x3,00	2	37,0	125 x 33 x 24,0	604,10	75 x 30	254,99
M 22x2,00	2	20,00	80 x 22 x 14,5	171,59*	55 x 16	113,28*	M 42x1,50	2	40,5	110 x 25 x 24,0	598,49	75 x 20	279,95
<b>M 22x2,50</b>	<b>3</b>	<b>19,50</b>	100 x 40 x 14,5	155,42*	55 x 22	90,55*	M 42x2,00	2	40,0	125 x 33 x 24,0	709,47	75 x 20	296,02
M 23x1,00	2	22,00	80 x 22 x 14,5	315,16	55 x 16	195,57	M 42x3,00	2	39,0	125 x 33 x 24,0	712,52	75 x 30	279,95
M 23x1,50	2	21,50	80 x 22 x 14,5	313,93	55 x 16	231,86	<b>M 42x4,50</b>	<b>3</b>	<b>37,5</b>	150 x 53 x 24,0	682,61	75 x 30	217,61
M 24x1,00	2	23,00	90 x 22 x 14,5	190,42	55 x 16	115,43	M 45x1,50	2	43,5	110 x 25 x 29,0	653,71	90 x 22	327,13
M 24x1,25	2	22,75	90 x 22 x 14,5	311,22	55 x 16	153,25	M 45x2,00	2	43,0	125 x 33 x 29,0	852,03	90 x 22	355,13
M 24x1,50	2	22,50	90 x 22 x 14,5	137,13	55 x 16	103,73	M 45x3,00	2	42,0	125 x 33 x 29,0	852,03	90 x 36	370,53
M 24x2,00	2	22,00	90 x 22 x 14,5	204,61*	55 x 16	115,43*	<b>M 45x4,50</b>	<b>3</b>	<b>40,5</b>	160 x 60 x 29,0	788,03	90 x 36	337,20
<b>M 24x3,00</b>	<b>3</b>	<b>21,00</b>	110 x 50 x 14,5	185,38*	55 x 22	90,55*	M 48x1,50	2	46,5	140 x 33 x 29,0	729,83	90 x 22	319,67
M 25x1,00	2	24,00	90 x 22 x 14,5	268,63	55 x 16	175,18	M 48x2,00	2	46,0	140 x 33 x 29,0	1.113,54	90 x 22	350,15
M 25x1,25	2	23,75	90 x 22 x 14,5	351,81	55 x 16	230,66	M 48x3,00	2	45,0	140 x 33 x 29,0	1.032,49	90 x 36	337,79
M 25x1,50	2	23,50	90 x 22 x 14,5	253,44	55 x 16	150,69	<b>M 48x5,00</b>	<b>3</b>	<b>43,0</b>	180 x 65 x 29,0	948,78	90 x 36	337,60
M 25x2,00	2	23,00	90 x 22 x 14,5	458,14	55 x 16	224,26	M 50x1,50	2	48,5	140 x 33 x 29,0	798,16	90 x 22	333,33
M 26x1,00	2	25,00	90 x 22 x 14,5	240,13	55 x 16	173,63	M 50x3,00	2	57,0	140 x 33 x 29,0	1.065,89	90 x 22	363,28
M 26x1,50	2	24,50	90 x 22 x 14,5	225,30	55 x 16	139,98	M 52x1,50	2	50,5	140 x 33 x 32,0	837,23	90 x 22	340,38
M 26x2,00	2	24,00	90 x 22 x 14,5	264,35	55 x 16	196,21	M 52x2,00	2	50,0	140 x 33 x 32,0	1.214,75	90 x 22	395,57
M 27x1,00	2	26,00	90 x 22 x 16,0	264,37	65 x 18	156,19	M 52x3,00	2	49,0	140 x 33 x 32,0	1.118,40	90 x 36	431,67
M 27x1,50	2	25,50	90 x 22 x 16,0	255,26	65 x 18	156,86	<b>M 52x5,00</b>	<b>3</b>	<b>47,0</b>	180 x 65 x 32,0	1.136,36	90 x 36	337,60
M 27x2,00	2	25,00	90 x 22 x 16,0	283,57*	65 x 18	170,60*	<b>M 56x4,00</b>	<b>2</b>	<b>52,0</b>	180 x 47 x 32,0	1.247,09	105 x 36	
<b>M 27x3,00</b>	<b>3</b>	<b>24,00</b>	110 x 50 x 16,0	234,42*	65 x 25	137,35*	<b>M 56x5,50</b>	<b>3</b>	<b>50,5</b>	200 x 85 x 35,0	1.763,76	105 x 36	
M 28x1,00	2	27,00	90 x 22 x 16,0	446,20	65 x 18	201,90	<b>M 60x5,50</b>	<b>3</b>	<b>54,5</b>	200 x 85 x 35,0	1.832,90	105 x 36	
M 28x1,50	2	26,50	90 x 22 x 16,0	250,28	65 x 18	142,20	<b>M 64x4,00</b>	<b>2</b>	<b>60,0</b>	180 x 50 x 35,0	1.756,34	120 x 36	
M 28x2,00	2	26,00	90 x 22 x 16,0	299,45	65 x 18	199,93	<b>M 64x6,00</b>	<b>3</b>	<b>58,0</b>	220 x 90 x 39,0	2.168,78	120 x 36	
M 30x1,00	2	29,00	90 x 22 x 18,0	277,93	65 x 18	165,52	<b>M 68x6,00</b>	<b>3</b>	<b>62,0</b>	220 x 90 x 39,0	2.596,44	120 x 36	
M 30x1,50	2	28,50	90 x 22 x 18,0	266,73	65 x 18	156,85	<b>M 72x6,00</b>	<b>3</b>	<b>66,0</b>	235 x 90 x 39,0	2.812,95	120 x 36	
M 30x2,00	2	28,00	90 x 22 x 18,0	307,51	65 x 18	173,83	<b>COJINETES CON MEDIDA EXTERIOR EN PULGADAS</b>						
M 30x3,00	2	27,00	125 x 56 x 18,0	300,62*	65 x 25	193,63*	C5						
<b>M 30x3,50</b>	<b>3</b>	<b>26,50</b>	125 x 50 x 18,0	301,60*	65 x 25	137,70*		Ø x L3 mm	€		Ø x L3 mm	€	
M 32x1,00	2	31,00	90 x 22 x 18,0	366,52	65 x 18	213,79	M 3x0,50	25,4 x 9,5	25,32	M 8x1,25	38,1 x 12,7	26,88	
M 32x1,50	2	30,50	90 x 22 x 18,0	317,59	65 x 18	162,68	M 4x0,70	25,4 x 9,5	25,32	M 10x1,50	25,4 x 9,5	34,02	
M 32x2,00	2	30,00	90 x 22 x 18,0	454,59	65 x 18	198,14	M 5x0,80	25,4 x 9,5	25,80	M 10x1,50	38,1 x 12,7	34,02	
M 33x1,00	2	32,00	100 x 25 x 20,0	584,92	65 x 18	226,37	M 6x1,00	25,4 x 9,5	25,32	M 12x1,75	25,4 x 9,5	40,99	
M 33x1,50	2	31,50	100 x 25 x 20,0	339,67	65 x 18	153,93	M 8x1,25	25,4 x 9,5	26,88	M 12x1,75	38,1 x 12,7	40,99	
M 33x2,00	2	31,00	100 x 25 x 20,0	428,84	65 x 18	154,99							
M 33x3,00	2	30,00	125 x 56 x 20,0	541,12*	65 x 25	239,18*							

\* Consulte el precio de machos y terrajas a izquierdas disponibles en Pag.188  
\* Recargo por cojinetes abiertos 20% sobre los precios tarifados

**JUEGOS DE MACHOS Y TERRAJAS PARA ROSCAR A MANO HSS**

UNC

Ref. M0

Ref. C5

HSS	DIN 351	TOL 2B
HSS	DIN 223	TOL 2a

UNF

Ref. M0

Ref. C5

HSS	DIN 2181	TOL 2B
HSS	DIN 223	TOL 2a



UNC	Uds.	D1 mm	L1 mm	L2 mm	L3 mm	M0		C5	
						€	Ø x L3 mm	€	
UNC nº1-64h.	3	1,85	1,50	36x8x2,1		110,43	16x5		
UNC nº2-56h.	3	2,18	1,80	36x9x2,1		78,04	16x5		
UNC nº3-48h.	3	2,51	2,10	40x9x2,1		78,04	16x5		
UNC nº4-40h.	3	2,84	2,25	40x11x2,7		59,10	20x5	43,85	
UNC nº5-40h.	3	3,17	2,60	40x11x2,7		56,50	20x5	43,97	
UNC nº6-32h.	3	3,50	2,75	45x13x3,0		56,50	20x7	43,97	
UNC nº8-32h.	3	4,17	3,50	45x13x3,4		56,50	20x7	43,97	
UNC nº10-24h.	3	4,83	3,90	50x16x4,9		56,50	20x7	43,97	
UNC nº12-24h.	3	5,49	4,50	50x19x4,9		56,50	20x7	43,97	
UNC 1/4-20h.	3	6,35	5,10	50x19x4,9		48,42*	20x7	41,44*	
UNC 5/16-18h.	3	7,94	6,60	56x22x4,9		54,97*	25x9	42,52*	
UNC 3/8-16h.	3	9,52	8,00	70x24x5,5		62,54*	30x11	59,12*	
UNC 7/16-14h.	3	11,11	9,40	70x24x6,2		81,44	38x14	59,12	
UNC 1/2-13h.	3	12,70	10,75	75x29x7,0		93,70*	38x14	60,77*	
UNC 9/16-12h.	3	14,28	12,20	80x30x9,0		110,62	38x14	63,60	
UNC 5/8-11h.	3	15,87	13,50	80x32x9,0		152,56*	45x18	86,21*	
UNC 3/4-10h.	3	19,05	16,50	95x40x11,0		207,87*	45x18	86,21*	
UNC 7/8-9h.	3	22,22	19,50	100x40x14,5		255,89	55x22	120,36	
UNC 1"-8h.	3	25,40	22,25	110x50x14,5		345,54*	55x22	115,72*	
UNC 1.1/8-7h.	3	28,57	25,00	125x56x18,0		520,99	65x25	171,90	
UNC 1.1/4-7h.	3	31,75	28,00	125x56x18,0		655,77	65x25	171,90	
UNC 1.3/8-6h.	3	34,92	30,75	150x63x22,0		831,92	65x25	171,90	
UNC 1.1/2-6h.	3	38,10	34,00	150x63x24,0		1.021,43	75x30	268,02	
UNC 2"-4,5h.	3	50,80	45,00	180x75x32,0		2.200,08	90x36		

UNF	Uds.	D1 mm	L1 mm	L2 mm	L3 mm	M0		C5	
						€	Ø x L3 mm	€	
UNF nº2-64h.	2	2,18	1,85	36x8x2,1		70,71			
UNF nº3-56h.	2	2,51	2,15	40x9x2,1		70,71			
UNF nº4-48h.	2	2,84	2,35	40x9x2,7		44,06	20x5	45,57	
UNF nº5-44h.	2	3,17	2,70	45x10x2,7		44,06	20x5	43,97	
UNF nº6-40h.	2	3,50	2,95	45x16x3,0		42,11	20x5	43,97	
UNF nº8-36h.	2	4,17	3,50	50x12x3,4		42,11	20x7	43,97	
UNF nº10-32h.	2	4,83	4,10	50x12x4,9		42,11	20x7	43,97	
UNF nº12-28h.	2	5,49	4,60	50x12x4,9		44,06	20x7	43,97	
UNF 1/4-28h.	2	6,35	5,50	50x14x4,9		32,14*	25x9	38,82*	
UNF 5/16-24h.	2	7,94	6,90	56x22x4,9		34,41*	25x9	43,33*	
UNF 3/8-24h.	2	9,52	8,50	63x20x5,5		39,73*	38x10	59,12*	
UNF 7/16-20h.	2	11,11	9,90	63x20x6,2		52,72	38x10	58,00	
UNF 1/2-20h.	2	12,70	11,50	70x22x7,0		53,94*	38x10	63,19*	
UNF 9/16-18h.	2	14,29	12,90	70x22x9,0		70,29	38x10	66,15	
UNF 5/8-18h.	2	15,87	14,50	70x22x9,0		90,80*	45x14	86,21*	
UNF 3/4-16h.	2	19,05	17,50	80x22x11,0		121,96*	45x14	86,21*	
UNF 7/8-14h.	2	22,22	20,40	80x22x14,5		156,74*	55x16	115,72*	
UNF 1"-12h.	2	25,40	23,25	90x22x16,0		207,83	55x16	115,72	
UNF 1"-14h.	2	25,40	23,60	90x22x14,5		230,23*	55x16	125,74*	
UNF 1.1/8-12h.	2	28,57	26,50	90x22x18,0		306,75	65x18	140,93	
UNF 1.1/4-12h.	2	31,75	29,50	90x22x20,0		374,63	65x18	178,78	
UNF 1.3/8-12h.	2	34,92	32,80	125x35x22,0		505,42	65x18	187,15	
UNF 1.1/2-12h.	2	38,10	36,00	125x40x22,0		638,51	75x20	268,02	
UNF 2"-12h.	2	50,80	48,38	140x40x29,0		1.579,94	90x22		

JUEGOS DE MACHOS Y TERRAJAS PARA ROSCAR A MANO HSS



Icono	Uds.	D1 mm	L1 x L2 x mm	M0		C5		Icono	Uds.	MOT		C5T		MOX		CSX	
				HSS	€	HSS	€			HSS	€	HSS	€	HSSCo	OX	HSSCo	OX
G 1/8-28h.	2	9,73	8,80	63 x 20 x 5,5	35,93*	38 x 10	52,86*	G 1/8-28 h.	2	78,20	98,55	89,85	67,01				
G 1/4-19h.	2	13,16	11,80	70 x 22 x 9,0	50,64*	38 x 10	52,58*	G 1/4-19 h.	2	142,27	101,99	161,46	69,12				
G 3/8-19h.	2	16,66	15,25	70 x 22 x 9,0	63,57*	45 x 14	69,64*	G 3/8-19 h.	2	173,58	114,73	200,57	82,22				
G 1/2-14h.	2	20,95	19,00	80 x 22 x 12,0	89,16*	45 x 14	69,64*	G 1/2-14 h.	2	244,64	129,87	270,62	90,98				
G 5/8-14h.	2	22,91	21,00	80 x 22 x 14,5	114,08*	55 x 16	96,61*										
G 3/4-14h.	2	26,44	24,50	90 x 22 x 16,0	139,17*	55 x 16	125,76*	G 3/4-14 h.	2	320,95	211,59	388,44	155,18				
G 7/8-14h.	2	30,20	28,25	90 x 22 x 18,0	187,36	65 x 18	149,71										
G 1"-11h.	2	33,25	30,75	100 x 25 x 20,0	220,63*	65 x 18	151,16*	G 1" -11 h.	2	559,37	282,63	638,89	185,39				
G 1.1/8-11h.	2	37,90	35,50	125 x 40 x 22,0	352,09	75 x 20	213,34										
G 1.1/4-11h.	2	41,91	39,50	125 x 40 x 24,0	383,69*	75 x 20	209,42*										
G 1.3/8-11h.	2	44,32	42,00	125 x 40 x 29,0	521,14	90 x 22	328,17										
G 1.1/2-11h.	2	47,80	45,25	140 x 40 x 29,0	579,86	90 x 22	316,12										
G 1.3/4-11h.	2	53,75	51,25	140 x 40 x 32,0	964,01	105 x 22	328,17										
G 2"-11h.	2	59,61	57,00	160 x 40 x 35,0	1.071,90	105 x 22	394,95										
G 2.1/4-11h.	2	65,71	63,00	160 x 40 x 39,0	1.770,67	105 x 22											
G 2.1/2-11h.	2	75,18	72,50	160 x 40 x 39,0	2.661,51	120 x 22											
G 2.3/4-11h.	2	81,53	79,00	160 x 40 x 39,0	3.227,33	120 x 22											
G 3"-11h.	2	87,88	85,50	160 x 40 x 39,0	3.358,99	150 x 25											
G 4"-11h.	2	113,03	110,50	180 x 45 x 44,0	5.094,44	180 x 25											



Icono	Uds.	D1 mm	L1 x L2 x mm	€
UNF n°4-48-3B	2	2,84	40x9x2,7	56,12
UNF n°5-44-3B	2	3,17	45x10x2,7	56,12
UNF n°6-40-3B	2	3,50	45x16x3,0	52,94
UNF n°8-36-3B	2	4,17	50x12x3,4	52,94
UNF n°10-32-3B	2	4,83	50x12x4,9	52,94
UNF n°12-28-3B	2	5,49	50x12x4,9	56,12
UNF 1/4-28-3B	2	6,35	50x14x4,9	40,93
UNF 5/16-24-3B	2	7,94	56x22x4,9	43,82
UNF 3/8-24-3B	2	9,52	63x20x5,5	50,59
UNF 7/16-20-3B	2	11,11	63x20x6,2	67,16
UNF 1/2-20-3B	2	12,70	70x22x7,0	68,70

\* Consulte el precio de machos y terrajas a izquierdas disponibles en Pag.188

Machos y Terrajas  
Verde Rosa

**JUEGOS DE MACHOS Y TERRAJAS PARA ROSCAR A MANO HSS**

Machos y Terrajas

Rosa  
Verde

**BSW**

Ref. M0

HSS

DIN 351

TOL Clase 2

Ref. C5

HSS

DIN 223

**BSF**

Ref. M0

HSS

DIN 5157

TOL ISO 228

Ref. C5

HSS

DIN 223

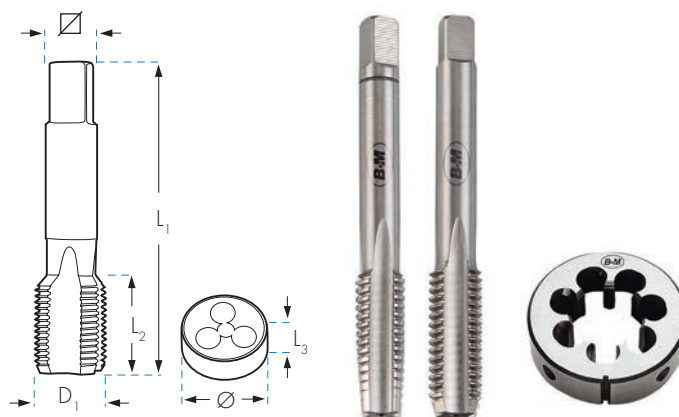

Icono	Uds.	D1 mm	L1 x L2 x ∅	M0		C5	
				€	∅ x L3 mm	€	∅ x L3 mm
W 1/16-60h.	3	1,59	1,15	32x8x2,1	60,71	16x5	81,70
W 3/32-48h.	3	2,38	1,80	40x9x2,1	44,39	20x5	42,16
W 1/8-40h.	3	3,17	2,55	40x14x2,7	31,88*	25x9	33,27*
W 5/32-32h.	3	3,97	3,10	45x17x3,4	32,21	25x9	33,94
W 3/16-24h.	3	4,76	3,60	50x19x4,9	31,88	25x9	33,27
W 7/32-24h.	3	5,55	4,40	50x19x4,9	52,44	25x9	43,46
W 1/4-20h.	3	6,35	5,10	50x20x4,9	35,91*	25x9	33,94*
W 5/16-18h.	3	7,94	6,50	56x20x4,9	43,86*	25x9	35,40*
W 3/8-16h.	3	9,52	7,90	63x22x5,5	48,19*	38x10	51,23*
W 7/16-14h.	3	11,11	9,25	70x22x6,2	64,69	38x10	51,30
W 1/2-12h.	3	12,70	10,50	75x25x7,0	69,42	38x14	50,34
W 9/16-12h.	3	14,29	12,00	80x26x9,0	94,44	38x14	61,48
W 5/8-11h.	3	15,87	13,40	80x27x9,0	108,60*	45x18	73,11*
W 11/16-11h.	3	17,46	15,25	95x32x11,0	255,93	45x18	120,43
W 3/4-10h.	3	19,05	16,50	95x32x11,0	154,60*	45x18	73,22*
W 7/8-9h.	3	22,22	19,25	100x32x14,5	211,14*	55x22	107,66*
W 1"-8h.	3	25,40	21,75	110x36x14,5	258,75*	55x22	108,64*
W 1.1/8-7h.	3	28,57	24,75	125x40x18,0	383,52	65x25	171,07
W 1.1/4-7h.	3	31,75	27,75	125x40x18,0	464,02	65x25	171,14
W 1.3/8-6h.	3	34,92	30,50	150x50x22,0	577,03	65x25	174,30
W 1.1/2-6h.	3	38,10	33,50	150x50x24,0	694,72	75x30	264,95
W 1.5/8-5h.	3	41,27	46,50	150x56x24,0	966,99	75x30	329,91
W 1.3/4-5h.	3	44,45	39,00	160x58x29,0	1.190,14	90x36	415,20
W 1.7/8-4,5h.	3	47,62	42,00	180x65x29,0	1.537,13	90x36	454,32
W 2"-4,5h.	3	50,80	44,50	180x65x32,0	1.613,72	90x36	476,13
W 2.1/4-4h.	3	57,15	50,00	200x85x35,0	2.673,86	105x36	
W 2.1/2-4h.	3	63,50	56,50	220x85x39,0	3.252,80	120x36	
W 2.3/4-3,5h.	3	69,85	62,00	250x90x44,0	4.644,61	120x36	
W 3"-3,5h.	3	76,20	68,00	250x90x44,0	5.373,30	140x36	

Icono	Uds.	D1 mm	L1 x L2 x ∅	M0		C5	
				€	∅ x L3 mm	€	∅ x L3 mm
BSF 3/16-32h.	2	4,76	4,0	50x19x4,9	119,98	20x7	43,78
BSF 1/4-26h.	2	6,35	5,2	50x20x4,9	48,80	20x7	48,48
BSF 5/16-22h.	2	7,94	6,6	56x20x4,9	56,90	25x9	49,03
BSF 3/8-20h.	2	9,52	8,1	63x22x5,5	65,85	30x11	94,18
BSF 7/16-18h.	2	11,11	9,5	70x22x6,2	79,02	30x11	93,31
BSF 1/2-16h.	2	12,70	11,0	75x25x7,0	89,40	38x10	81,43
BSF 9/16-16h.	2	14,29	12,5	80x26x9,0	107,16	38x10	85,93
BSF 5/8-14h.	2	15,88	14,0	80x26x9,0	140,23	45x14	133,96
BSF 3/4-12h.	2	19,05	16,5	95x33x11,0	214,34	45x14	135,20
BSF 7/8-11h.	2	22,23	19,5	100x33x14,5	255,83	55x22	181,31
BSF 1"-10h.	2	25,40	22,5	110x40x14,5	359,11	55x22	179,30
BSF 1.1/8-9h.	2	28,57	25,5	110x40x16,0	810,29		
BSF 1.1/4-9h.	2	31,75	28,5	125x46x18,0	925,10		
BSF 1.1/2-8h.	2	38,10	34,5	150x55x22,0	1.409,91		



**BSW**

**INOX**

**TiN**





Icono	Uds.	L1 x L2 x ∅	M0T		C5T	
			€	∅ x L3 mm	€	∅ x L3 mm
W 3/16-24 h.	3	50 x 19 x 4,90	60,87	25x9	60,84	
W 1/4-20 h.	3	50 x 20 x 4,90	68,14	25x9	61,96	
W 5/16-18 h.	3	56 x 20 x 4,90	74,66	25x9	64,41	
W 3/8-16 h.	3	63 x 22 x 5,50	87,87	38x10	76,14	
W 1/2-12 h.	3	75 x 25 x 7,00	124,00	38x14	102,29	

\* Consulte el precio de machos y terrajas a izquierdas disponibles en Pag.188

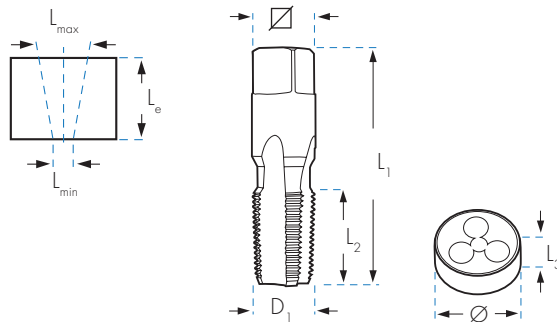
MACHOS Y TERRAJAS PARA ROSCAR A MANO HSS





**NPTF**  Rosca AMERICANA  
Rosca Cónica estanca Ref. M0 **HSS** Ref. C5 **HSS** **DIN 223**

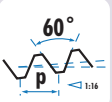

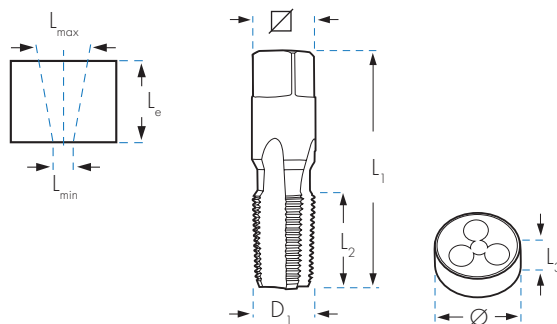
							M0	C5		
		Uds.	D1 mm		L <sub>min</sub> x L <sub>max</sub> mm	L <sub>e</sub> mm	L <sub>1</sub> x L <sub>2</sub> x  mm	€	Ø x L <sub>3</sub> mm	€
NPTF	1/8-27 h.	1	10,22	8,5	8,30 x 8,76	12,0	54 x 19 x 8,0	97,82	38 x 10	213,61
NPTF	1/4-18 h.	1	13,58	11,0	10,70 x 11,40	17,5	62 x 27 x 11,0	137,10	38 x 15	213,61
NPTF	3/8-18 h.	1	17,02	14,5	14,20 x 14,84	17,6	65 x 27 x 13,0	189,25	45 x 14	278,91
NPTF	1/2-14 h.	1	21,21	17,8	17,40 x 18,33	22,8	80 x 35 x 13,0	264,64	45 x 20	278,91
NPTF	3/4-14 h.	1	26,56	23,0	22,80 x 23,68	23,0	83 x 35 x 17,0	404,52	55 x 22	531,58
NPTF	1"-11,5 h.	1	33,19	29,0	28,60 x 29,72	27,4	110 x 38 x 20,0	538,83		

**NPT**  Rosca AMERICANA  
Rosca Cónica no estanca (Briggs) Ref. M0 **HSS** Ref. C5 **HSS** **DIN 223**

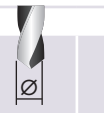

								M0	C5		
		Uds.	D1 mm			L <sub>min</sub> x L <sub>max</sub> mm	L <sub>e</sub> mm	L <sub>1</sub> x L <sub>2</sub> x  mm	€	Ø x L <sub>3</sub> mm	€
NPT	1/16-27 h.	1	7,89	6,20	EMNPT1/16	6,00 x 6,38	12,0	54 x 18 x 6,0	37,14	25 x 9	122,79
NPT	1/8-27 h.	1	10,24	8,50	EMNPT1/8	8,30 x 8,73	12,0	65 x 19 x 5,5	37,14	30 x 11	90,79
NPT	1/4-18 h.	1	13,62	11,00	EMNPT1/4	10,70 x 11,35	17,5	62 x 27 x 11,0	52,11	38 x 14	90,79
NPT	3/8-18 h.	1	17,05	14,50	EMNPT3/8	14,20 x 14,80	17,6	65 x 27 x 13,0	71,91	45 x 18	118,52
NPT	1/2-14 h.	1	21,23	17,80	EMNPT1/2	17,40 x 18,32	22,8	80 x 35 x 13,0	100,55	45 x 18	118,52
NPT	3/4-14 h.	1	26,57	23,00	-	22,80 x 23,66	23,0	83 x 35 x 17,0	153,72	55 x 22	216,82
NPT	1"-11,5 h.	1	33,23	29,00	-	28,60 x 29,69	27,4	95 x 44 x 21,0	171,20	65 x 25	260,65
NPT	1.1/4-11,5 h.	1	41,98	37,50	-	37,40 x 38,45	28,1	125 x 33 x 24,0	280,70	75 x 26	323,90
NPT	1.1/2-11,5 h.	1	48,05	44,00	-	43,40 x 44,52	28,4	140 x 33 x 29,0	426,53	90 x 27	451,90
NPT	2"-11,5 h.	1	60,09	56,00	-	55,50 x 56,56	28,4	160 x 33 x 35,0	665,90	105 x 36	629,16
NPT	2.1/2"-8h.	1	73,03	67,00	-	68,68 x 69,08	28,9	200 x 45 x 39,0	813,66		
NPT	3"-8h.	1	88,90	82,00	-	84,45 x 84,86	30,5	220 x 48 x 39,0	1.143,70		

\* Ver escariador previo pag.137

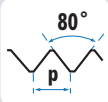
**MACHOS Y TERRAJAS PARA ROSCAR A MANO HSS**
**PG**

Ref. M0

**HSS**
**DIN  
40430**

Ref. C5

**HSS**
**DIN  
223**

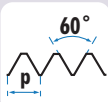

	Uds.	D <sub>1</sub> mm		L <sub>1</sub> x L <sub>2</sub> x	M0		C5	
					€	Ø x L <sub>3</sub> mm	€	
Pg 7	20h.	1	12,5	11,50	70x20x7,0	35,61	38x10	65,48
Pg 9	18h.	1	15,2	14,00	70x20x9,0	45,27	38x10	65,48
Pg 11	18h.	1	18,6	17,25	80x22x11,0	62,86	45x14	81,98
Pg 13,5	18h.	1	20,4	19,00	80x22x12,0	68,93	45x14	81,98
Pg 16	18h.	1	22,5	21,25	80x22x14,5	82,79	55x16	105,76
Pg 21	16h.	1	28,3	27,00	90x22x18,0	121,74	65x18	150,33
Pg 29	16h.	1	37,0	35,50	100x25x22,0	241,73	65x18	150,33
Pg 36	16h.	1	47,0	45,50	140x32x29,0	396,70	90x22	385,31
Pg 42	16h.	1	54,0	52,50	140x36x32,0	471,11	105x22	385,31
Pg 48	16h.	1	59,3	58,00	160x36x35,0	594,16	105x22	510,96

**NPSF**

 Rosca AMERICANA  
 Rosca Cilindrica estanca

Ref. M0

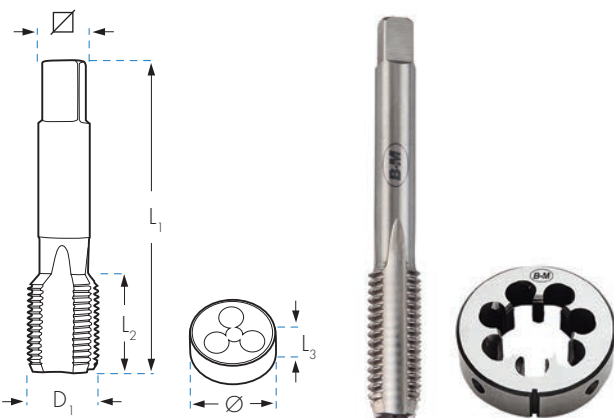
**HSS**

Ref. C5

**HSS**
**DIN  
223**

	Uds.	D <sub>1</sub> mm		L <sub>1</sub> x L <sub>2</sub> x	M0		C5	
					€	Ø x L <sub>3</sub> mm	€	
NPSF 1/8-27 h.	1	10,05	8,75	63x18x5,5	147,30	38x10	256,60	
NPSF 1/4-18 h.	1	13,35	11,30	70x20x9,0	212,85	38x10	256,60	
NPSF 3/8-18 h.	1	16,78	14,70	70x20x9,0	294,42	45x14	326,43	
NPSF 1/2-14 h.	1	20,87	18,20	80x22x12,0	384,88	45x14	326,43	
NPSF 3/4-14 h.	1	26,23	23,50	90x22x16,0	585,61	55x16	705,59	

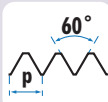
**NPS  
(M)**

 Rosca AMERICANA  
 Rosca Cilindrica no estanca

Ref. M0

**HSS**

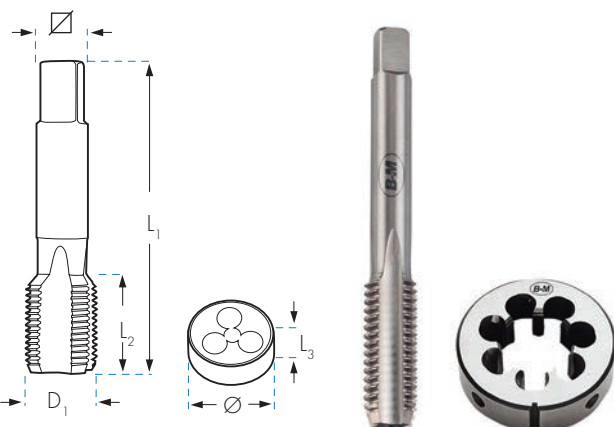
Ref. C5

**HSS**
**DIN  
223**







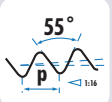

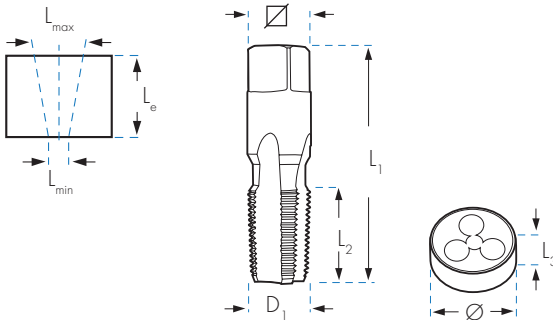



	Uds.	D <sub>1</sub> mm		L <sub>1</sub> x L <sub>2</sub> x	M0		C5	
					€	Ø x L <sub>3</sub> mm	€	
NPS 1/8-27 h.	1	10,20	8,9	63x18x5,5	122,05	38x10	213,78	
NPS 1/4-18 h.	1	13,60	11,7	70x20x9,0	97,13	38x10	213,78	
NPS 3/8-18 h.	1	17,00	15,0	70x20x9,0	134,34	45x14	272,01	
NPS 1/2-14 h.	1	21,20	18,6	80x22x12,0	175,59	45x14	272,01	
NPS 3/4-14 h.	1	26,55	24,0	90x22x16,0	254,99	55x16	538,85	
NPS 1"-11,5 h.	1	33,20	30,0	100x25x20,0	356,54	65x18	543,05	



**JUEGOS DE MACHOS Y TERRAJAS PARA ROSCAR A MANO HSS**







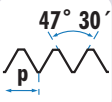

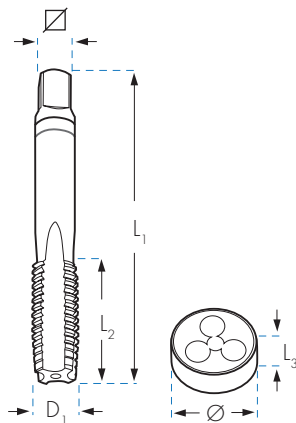



**BSPT**  Ref. M0 **HSS** **DIN 5157** Ref. C5 **HSS** **DIN 223**



		Uds.	D <sub>1</sub> mm		L <sub>min</sub> x L <sub>max</sub> mm	L <sub>e</sub> mm	L <sub>1</sub> x L <sub>2</sub> x 	€	Ø x L <sub>3</sub> mm	€
BSPT 1/8-28 h.		1	9,73	8,30	8,00 x 8,50	10,1	65 x 19 x 5,5	33,25	30 x 11	99,12
BSPT 1/4-19 h.		1	13,16	11,00	10,70 x 11,35	15,0	70 x 25 x 9,0	46,85	38 x 14	99,12
BSPT 3/8-19 h.		1	16,66	14,50	14,15 x 14,25	15,4	70 x 25 x 9,0	65,06	45 x 16	129,09
BSPT 1/2-14 h.		1	20,95	18,10	17,60 x 18,50	20,5	80 x 31 x 12,0	91,10	55 x 22	129,09
BSPT 5/8-14 h.		1	22,91	20,00	19,50 x 20,40	22,4	80 x 36 x 14,5	159,76	55 x 19	269,37
BSPT 3/4-14 h.		1	26,44	23,50	23,00 x 24,00	21,8	85 x 33 x 16,0	148,65	55 x 22	243,78
BSPT 7/8-14 h.		1	30,20	27,25	26,65 x 28,75	24,0	100 x 36 x 18,0	281,71	65 x 22	351,92
BSPT 1"-11 h.		1	33,25	29,60	29,00 x 30,20	26,0	110 x 38 x 20,0	235,42	65 x 25	281,51

**BA**  Ref. M0 **HSS** **DIN 352** Ref. C5 **HSS** **DIN 223**



		Uds.	D <sub>1</sub> mm		L <sub>1</sub> x L <sub>2</sub> x 	€	Ø x L <sub>3</sub> mm	€	
BA-0		1,00	3	6,0	5,1	50 x 18 x 4,9	207,17	20 x 5	161,97
BA-1		0,90	3	5,3	4,5	50 x 18 x 4,9	207,17	20 x 5	161,97
BA-2		0,81	3	4,7	4,0	50 x 17 x 4,9	207,17	20 x 5	161,97
BA-3		0,73	3	4,1	3,4	45 x 14 x 3,4	222,63	20 x 5	161,97
BA-4		0,66	3	3,6	3,0	45 x 14 x 3,0	222,63	20 x 5	161,97
BA-5		0,59	3	3,2	2,6	45 x 14 x 3,0	266,01	20 x 5	161,97
BA-6		0,53	3	2,8	2,3	40 x 12 x 2,7	266,01	20 x 5	161,97
BA-7		0,48	3	2,5	2,0	40 x 10 x 2,1	292,46	20 x 5	161,97
BA-8		0,43	3	2,2	1,8	36 x 10 x 2,1	292,46	20 x 5	161,97

**JUEGOS DE MACHOS Y TERRAJAS PARA ROSCAR A MANO HSS**

Machos y Terrajas

Verde

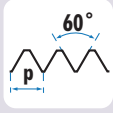
**UNx8**

Rosca AMERICANA

Ref. M0

HSS

DIN  
2181TOL  
2B

Ref. C5

HSS

DIN  
223TOL  
2a

	Uds.	D1 mm		L1 x L2 x $\nabla$ mm	M0		C5	
					€	Ø x L3 mm	€	
UN 1"1/8-8h.	2	28,57	25,40	138x65x170	390,67	65x25	427,89	
UN 1"1/4-8h.	2	31,75	28,50	146x65x19,5	506,63	65x25	427,89	
UN 1"3/8-8h.	2	34,92	31,75	154x76x21,0	630,11	65x25	426,01	
UN 1"1/2-8h.	2	38,10	35,00	162x76x23,5	721,11	75x30	482,28	
UN 1"5/8-8h.	2	41,27	38,10	170x80x25,0	896,53	75x30	504,81	
UN 1"3/4-8h.	2	44,45	41,25	178x81x27,0	1.117,32	90x36	673,10	
UN 1"7/8-8h.	2	47,62	44,45	186x90x29,0	1.393,92	90x36	720,20	
UN 2"-8h.	2	50,80	47,63	194x90x31,5	1.325,21	90x36	729,18	
UN 2"1/4-8h.	2	57,15	54,00	208x90x36,0				
UN 2"1/2-8h.	2	63,50	60,35	220x100x36,0				
UN 2"3/4-8h.	2	69,85	66,70	234x104x39,0				
UN 3"-8h.	2	76,20	73,05	248x115x49,0				

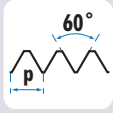
**UNEF**

Rosca AMERICANA

Ref. M0

HSS

DIN  
2181TOL  
2B

Ref. C5

HSS

DIN  
223TOL  
2a

	Uds.	D1 mm		L1 x L2 x $\nabla$ mm	M0		C5	
					€	Ø x L3 mm	€	
UNEF 1/4-32h.	2	6,35	5,55	65x28x4,9	105,00	20x7	106,61	
UNEF 5/16-32h.	2	7,94	7,15	70x30x6,0	117,31	25x9	106,61	
UNEF 3/8-32h.	2	9,52	8,70	75x33x7,0	134,25	30x11	165,54	
UNEF 7/16-28h.	2	11,11	10,20	81x38x6,0	170,89	30x11	165,54	
UNEF 1/2-28h.	2	12,70	11,80	86x44x7,0	193,10	38x10	165,54	
UNEF 9/16-24h.	2	14,29	13,20	92x44x8,0	157,85	38x10	165,54	
UNEF 5/8-24h.	2	15,87	14,80	93x47x9,0	162,59	45x14	265,34	
UNEF 3/4-20h.	2	19,05	17,80	108x52x11,0	178,94	45x14	265,34	
UNEF 7/8-20h.	2	22,22	20,95	120x58x13,0	271,56	55x16	315,63	
UNEF 1"-20h.	2	25,40	24,20	130x65x15,0	279,32	55x16	324,28	

**JUEGOS DE MACHOS PARA ROSCAR A MANO APLICACIONES ESPECIALES**

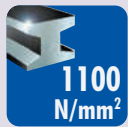

**1100**  
N/mm<sup>2</sup>

Ref. M0MD

**HSSCo**  
5%

**DIN**  
352

**OX**



ESPECIAL MATERIALES DUROS  
( ≤ 1100 N/mm<sup>2</sup>=40HRc )

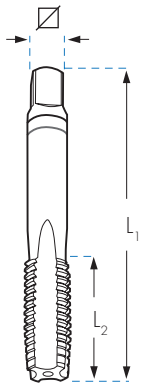

				M0MD
	Uds.		L <sub>1</sub> x L <sub>2</sub> x	€
M 3 x 0,50	3	2,50	40 x 11 x 2,7	38,32
M 4 x 0,70	3	3,30	45 x 13 x 3,4	38,32
M 5 x 0,80	3	4,20	50 x 17 x 4,9	39,56
M 6 x 1,00	3	5,00	50 x 19 x 4,9	40,73
M 8 x 1,25	3	6,80	56 x 20 x 4,9	46,31
M 10 x 1,50	3	8,50	70 x 22 x 5,5	59,44
M 12 x 1,75	3	10,20	75 x 24 x 7,0	85,11
M 14 x 2,00	3	12,00	80 x 26 x 9,0	100,74
M 16 x 2,00	3	14,00	80 x 27 x 9,0	133,85
M 18 x 2,50	3	15,50	95 x 30 x 11,0	205,86
M 20 x 2,50	3	17,50	95 x 32 x 12,0	228,55

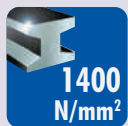

**1400**  
N/mm<sup>2</sup>

Ref. M0C

**HSS**  
PM

**TiAlSiN**



ESPECIAL MATERIALES MUY DUROS  
( ≤ 1400 N/mm<sup>2</sup>=44HRc )

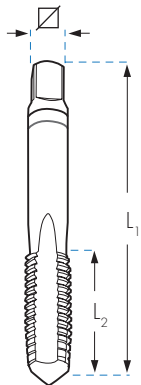

				M0C
	Uds.		L <sub>1</sub> x L <sub>2</sub> x	€
M 3 x 0,50	3	2,50	40 x 11 x 2,7	95,43
M 4 x 0,70	3	3,30	45 x 13 x 3,4	102,97
M 5 x 0,80	3	4,20	50 x 17 x 4,9	104,25
M 6 x 1,00	3	5,00	50 x 19 x 4,9	104,25
M 8 x 1,25	3	6,80	56 x 20 x 4,9	117,51
M 10 x 1,50	3	8,50	70 x 22 x 5,5	145,25
M 12 x 1,75	3	10,20	75 x 24 x 7,0	176,57
M 14 x 2,00	3	12,00	80 x 26 x 9,0	216,66
M 16 x 2,00	3	14,00	80 x 27 x 9,0	259,60
M 18 x 2,50	3	15,50	95 x 30 x 11,0	359,92
M 20 x 2,50	3	17,50	95 x 32 x 12,0	396,13

**Al**

Ref. M0AL

**HSS**

**BRILLANTE**



ESPECIAL ALUMINIO

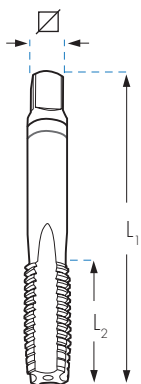

				M0AL
	Uds.		L <sub>1</sub> x L <sub>2</sub> x	€
M 3 x 0,50	3	2,50	40 x 11 x 2,7	29,84
M 4 x 0,70	3	3,30	45 x 13 x 3,4	28,97
M 5 x 0,80	3	4,20	50 x 17 x 4,9	30,70
M 6 x 1,00	3	5,00	50 x 19 x 4,9	30,70
M 8 x 1,25	3	6,80	56 x 20 x 4,9	37,68
M 10 x 1,50	3	8,50	70 x 22 x 5,5	46,01
M 12 x 1,75	3	10,20	75 x 24 x 7,0	64,78
M 14 x 2,00	3	12,00	80 x 26 x 9,0	74,44
M 16 x 2,00	3	14,00	80 x 27 x 9,0	105,66
M 18 x 2,50	3	15,50	95 x 30 x 11,0	140,04
M 20 x 2,50	3	17,50	95 x 32 x 12,0	157,87

## JUEGOS DE MACHOS Y TERRAJAS PARA ROSCAR A MANO INOXIDABLE

M

INOX

Ref. MOT  
Ref. MOXDIN  
352TOL  
6H

TiN

Ref. CST  
Ref. CSXDIN  
223TOL  
6g

OX

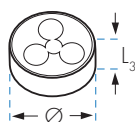
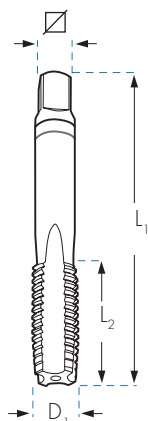

		Uds.	L <sub>1</sub> x L <sub>2</sub> x $\nabla$ mm	MOT	CST	MOX	CSX	Ø x L <sub>3</sub> mm
				HSS TiN €	HSS TiN €	HSSCo OX €	HSSCo OX €	
M	3 x 0,50	3	40 x 11 x 2,70	42,73	62,83	39,41	34,13	20 x 5
M	4 x 0,70	3	45 x 13 x 3,40	44,89	62,83	39,41	34,13	20 x 5
M	5 x 0,80	3	50 x 16 x 4,90	47,63	62,83	41,03	35,78	20 x 7
M	6 x 1,00	3	50 x 19 x 4,90	47,63	62,83	40,90	36,28	20 x 7
M	8 x 1,00	2	50 x 19 x 4,90	41,87				
M	8 x 1,25	3	56 x 22 x 4,90	54,93	64,41	47,60	39,35	25 x 9
M	10 x 1,00	2	63 x 18 x 5,50	48,31				
M	10 x 1,50	3	70 x 24 x 5,50	73,16	84,56	61,24	49,93	30 x 11
M	12 x 1,50	2	70 x 20 x 7,00	61,51				
M	12 x 1,75	3	75 x 29 x 7,00	84,88	93,76	87,70	52,75	38 x 14
M	14 x 1,50	2	70 x 20 x 9,00	73,86				
M	14 x 2,00	3	80 x 30 x 9,00	102,65	93,76	97,12	52,75	38 x 14
M	16 x 2,00	3	80 x 32 x 9,00	128,91	115,54	133,10	70,82	45 x 18
M	18 x 2,50	3	95 x 40 x 11,00	159,80		181,78		
M	20 x 2,50	3	95 x 40 x 12,00	165,71		201,77		
M	22 x 2,50	3	100 x 40 x 14,50	209,62				
M	24 x 3,00	3	110 x 50 x 14,50	252,59				

M

TERRAJAS HEXAGONALES HSS PARA ROSCAR A MANO

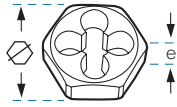

**M** HSS DIN 382

C5HM			C5HM		
		€			€
M 3 x 0,35	18 x 5	40,65	M 16 x 2,00	41 x 18	111,70
<b>M 3 x 0,50</b>	<b>19 x 5</b>	<b>40,65</b>	M 18 x 1,00	41 x 14	111,70
M 3,5 x 0,60	18 x 5	40,65	M 18 x 1,50	41 x 14	111,70
M 4 x 0,50	18 x 5	40,65	<b>M 18 x 2,50</b>	<b>41 x 18</b>	<b>111,70</b>
<b>M 4 x 0,70</b>	<b>19 x 5</b>	<b>40,65</b>	M 20 x 1,00	41 x 14	111,70
M 5 x 0,50	18 x 5	40,65	M 20 x 1,50	41 x 14	111,70
M 5 x 0,75	18 x 5	40,65	M 20 x 2,00	41 x 18	111,70
<b>M 5 x 0,80</b>	<b>19 x 7</b>	<b>40,65</b>	<b>M 20 x 2,50</b>	<b>41 x 18</b>	<b>111,70</b>
M 6 x 0,75	18 x 7	40,65	M 22 x 1,00	50 x 16	141,23
<b>M 6 x 1,00</b>	<b>19 x 7</b>	<b>40,65</b>	M 22 x 1,50	50 x 16	141,23
M 7 x 0,75	21 x 9	43,21	M 22 x 2,00	50 x 16	141,23
M 7 x 1,00	21 x 9	43,21	<b>M 22 x 2,50</b>	<b>50 x 16</b>	<b>141,23</b>
M 8 x 0,75	21 x 9	43,21	M 24 x 1,00	50 x 16	172,01
M 8 x 1,00	21 x 9	43,21	M 24 x 1,50	50 x 16	172,01
<b>M 8 x 1,25</b>	<b>22 x 9</b>	<b>43,21</b>	M 24 x 2,00	50 x 16	172,01
M 9 x 0,75	21 x 9	50,86	<b>M 24 x 3,00</b>	<b>50 x 22</b>	<b>141,23</b>
M 9 x 1,00	21 x 9	50,86	M 27 x 1,50	60 x 18	190,96
<b>M 9 x 1,25</b>	<b>22 x 9</b>	<b>50,86</b>	M 27 x 2,00	60 x 18	190,96
M 10 x 1,00	27 x 11	50,86	<b>M 27 x 3,00</b>	<b>60 x 25</b>	<b>159,13</b>
M 10 x 1,25	27 x 11	50,86	M 30 x 1,00	60 x 18	190,96
<b>M 10 x 1,50</b>	<b>27 x 11</b>	<b>50,86</b>	M 30 x 1,50	60 x 18	190,96
M 11 x 1,00	27 x 11	84,75	M 30 x 2,00	60 x 18	190,96
M 11 x 1,50	27 x 11	84,75	M 30 x 3,00	60 x 18	190,96
M 12 x 1,25	36 x 10	84,75	<b>M 30 x 3,50</b>	<b>60 x 25</b>	<b>159,13</b>
M 12 x 1,50	36 x 10	84,75	M 33 x 1,50	60 x 18	213,82
<b>M 12 x 1,75</b>	<b>36 x 10</b>	<b>71,20</b>	M 33 x 2,00	60 x 18	213,82
M 14 x 1,25	36 x 14	96,30	<b>M 33 x 3,50</b>	<b>60 x 25</b>	<b>178,19</b>
M 14 x 1,50	36 x 10	96,30	M 35 x 1,50	60 x 18	220,43
<b>M 14 x 2,00</b>	<b>36 x 10</b>	<b>71,20</b>	M 36 x 1,50	60 x 18	220,43
M 15 x 1,00	36 x 14	111,70	M 36 x 2,00	60 x 18	220,43
M 15 x 1,50	41 x 14	111,70	M 36 x 3,00	60 x 18	220,43
M 16 x 1,00	41 x 14	111,70	<b>M 36 x 4,00</b>	<b>60 x 25</b>	<b>183,69</b>
M 16 x 1,50	41 x 14	111,70			

**BSP (GAS)** HSS DIN 382

C5HG		
		€
G 1/8 x 28h.	27 x 11	89,51
G 1/4 x 19h.	36 x 10	89,51
G 3/8 x 19h.	41 x 14	111,94
G 1/2 x 14h.	41 x 14	111,94
G 5/8 x 14h.	50 x 16	263,56
G 3/4 x 14h.	50 x 16	263,56
G 7/8 x 14h.	60 x 18	265,90
G 1" x 11h.	60 x 18	265,90
G1.1/4 x 11h.	70 x 20	354,54
G1.1/2 x 11h.	85 x 22	598,13
G 2" x 11h.	100 x 22	900,05

**UNC** HSS DIN 382

C5HNC		
		€
UNC 1/4-20h	18 x 7	37,07
UNC 5/16-18h	21 x 9	46,13
UNC 3/8-16h	27 x 11	55,68
UNC 7/16-14h	27 x 11	82,17
UNC 1/2-13h	36 x 14	82,48
UNC 9/16-12h	36 x 14	98,56
UNC 5/8-11h	41 x 18	76,36
UNC 3/4-10h	41 x 18	121,47
UNC 7/8-9h	50 x 22	172,38
UNC 1"-8h	50 x 22	172,38
UNC 1.1/8-7h	60 x 25	227,91
UNC 1.1/4-7h	60 x 25	227,91

**UNF** HSS DIN 382

C5HNF		
		€
UNF 1/4-28h.	18 x 7	39,29
UNF 5/16-24h.	21 x 9	49,13
UNF 3/8-24h.	27 x 11	59,11
UNF 7/16-20h.	27 x 11	87,09
UNF 1/2-20h.	36 x 10	88,43
UNF 9/16-18h.	36 x 10	98,56
UNF 5/8-18h.	41 x 14	122,96
UNF 3/4-16h.	41 x 14	128,77
UNF 7/8-14h.	50 x 16	162,86
UNF 1"-12h.	50 x 16	170,72
UNS 1"-14h.	50 x 16	170,72
UNF 1.1/8-12h.	60 x 18	227,91
UNF 1.1/4-12h.	60 x 18	227,91

**BSW** HSS DIN 382

C5HW			C5HW		
		€			€
BSW 1/8 x 40h.	19 x 5	50,86	BSW 9/16 x 12h.	36 x 14	76,30
BSW 3/16 x 24h.	19 x 7	50,86	BSW 5/8 x 11h.	41 x 18	112,75
BSW 1/4 x 20h.	19 x 7	50,86	BSW 3/4 x 10h.	41 x 18	112,75
BSW 5/16 x 18h.	22 x 9	53,39	BSW 7/8 x 9h.	50 x 22	165,25
BSW 3/8 x 16h.	27 x 11	63,56	BSW 1" x 8h.	50 x 22	165,25
BSW 7/16 x 14h.	27 x 11	63,56	BSW 1.1/8 x 7h.	60 x 25	284,83
BSW 1/2 x 12h.	36 x 14	76,30			

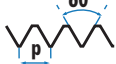
**JUEGOS DE MACHOS Y TERRAJAS PARA ROSCAR A MANO, ROSCA A IZQUIERDA**
**M**  
**MF**
**DIN 13**

Ref. MOI

**HSS**
**DIN 352**
**DIN 2181**
**TOL 6H**

Ref. CSI

**HSS**
**DIN 223**
**TOL 6g**

Para materiales hasta 38 HRC

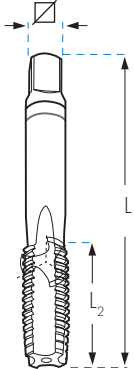

IZQUIERDA

**UNC**

	Uds.	D1 mm			L1 x L2 x L3 mm	MOI		CSI	
		mm	mm			€	Ø x L3 mm	€	
UNC 1/4-20h.	3	6,35	5,10		50x19x4,9	96,84	20x7	82,87	
UNC 5/16-18h.	3	7,94	6,60		56x22x4,9	109,94	25x9	85,03	
UNC 3/8-16h.	3	9,52	8,00		70x24x5,5	125,08	30x11	118,23	
UNC 1/2-13h.	3	12,70	10,75		75x29x7,0	187,41	38x14	121,54	
UNC 5/8-11h.	3	15,87	13,50		80x32x9,0	305,11	45x18	172,42	
UNC 3/4-10h.	3	19,05	16,50		95x40x11,0	415,73	45x18	172,42	
UNC 1"-8h.	3	25,40	22,25		110x50x14,5	691,08	55x22	231,44	

**UNF**

	Uds.	D1 mm			L1 x L2 x L3 mm	MOI		CSI	
		mm	mm			€	Ø x L3 mm	€	
UNF 1/4-28h.	2	6,35	5,50		50x14x4,9	64,28	25x9	77,63	
UNF 5/16-24h.	2	7,94	6,90		56x22x4,9	68,82	25x9	86,67	
UNF 3/8-24h.	2	9,52	8,50		63x20x5,5	79,46	38x10	118,23	
UNF 1/2-20h.	2	12,70	11,50		70x22x7,0	107,89	38x10	126,37	
UNF 5/8-18h.	2	15,87	14,50		70x22x9,0	181,60	45x14	172,42	
UNF 3/4-16h.	2	19,05	17,50		80x22x11,0	243,93	45x14	172,42	
UNS 1"-14h.	2	25,40	23,60		90x22x14,5	460,46	55x16	251,48	

**BSP (GAS)**

	Uds.	D1 mm			L1 x L2 x L3 mm	MOI		CSI	
		mm	mm			€	Ø x L3 mm	€	
G 1/8-28h.	2	9,73	8,80		63 x 20 x 5,5	71,87	38x10	105,72	
G 1/4-19h.	2	13,16	11,80		70 x 22 x 9,0	101,27	38x10	105,15	
G 3/8-19h.	2	16,66	15,25		70 x 22 x 9,0	127,14	45x14	139,28	
G 1/2-14h.	2	20,95	19,00		80 x 22 x 12,0	178,31	45x14	139,28	
G 5/8-14h.	2	22,91	21,00		80 x 22 x 14,5	228,15	55x16	193,22	
G 3/4-14h.	2	26,44	24,50		90 x 22 x 16,0	278,33	55x16	251,52	
G 1"-11h.	2	33,25	30,75		100 x 25 x 20,0	441,26	65x18	302,31	
G 1.1/4-11h.	2	41,91	39,50		125 x 40 x 24,0	767,38	75x20	418,85	

**BSW**

	Uds.	D1 mm			L1 x L2 x L3 mm	MOI		CSI	
		mm	mm			€	Ø x L3 mm	€	
W 1/8-40h.	3	3,17	2,55		40x14x2,7	63,77	25x9	66,55	
W 1/4-20h.	3	6,35	5,10		50x20x4,9	71,83	25x9	67,88	
W 5/16-18h.	3	7,94	6,50		56x20x4,9	87,73	25x9	70,81	
W 3/8-16h.	3	9,52	7,90		63x22x5,5	96,38	38x10	102,46	
W 5/8-11h.	3	15,87	13,40		80x27x9,0	217,19	45x18	146,22	
W 3/4-10h.	3	19,05	16,50		95x32x11,0	309,20	45x18	146,45	
W 7/8-9h.	3	22,22	19,25		100x32x14,5	422,28	55x22	215,33	
W 1"-8h.	3	25,40	21,75		110x36x14,5	517,49	55x22	217,28	

	Uds.	D1 mm			L1 x L2 x L3 mm	MOI		CSI	
		mm	mm			€	Ø x L3 mm	€	
M 2x0,40	3	1,60	36x9,0x2,1		78,65	16x5	64,96		
M 3x0,50	3	2,50	40x11,0x2,7		44,16	25x9	59,08		
M 4x0,70	3	3,30	45x13,0x3,4		44,12	25x9	59,38		
M 5x0,80	3	4,20	50x16,0x4,9		47,17	25x9	59,04		
M 6x1,00	3	5,00	50x19x4,9		47,17	25x9	59,08		
M 7x1,00	3	6,00	50x19x4,9		57,45	25x9	62,01		
M 8x1,00	2	7,00	56x18x4,9		53,00	25x9	68,54		
M 8x1,25	3	6,80	56x22x4,9		57,41	25x9	62,69		
M 9x1,25	3	7,80	63x22x5,5		94,04	25x9	72,86		
M 10x1,50	3	8,50	70x24x5,5		70,79	38x10	83,91		
M 12x1,50	2	10,50	70x20x7,0		85,50	38x10	105,15		
M 12x1,75	3	10,20	75x29x7,0		99,58	38x14	91,16		
M 14x1,25	2	12,80	70x20x9,0		122,51	38x10	136,40		
M 14x2,00	3	12,00	80x30x9,0		110,17	38x14	90,27		
M 16x1,50	2	14,50	70x20x9,0		118,55	45x14	130,61		
M 16x2,00	3	14,00	80x32x9,0		157,62	45x18	122,39		
M 18x2,00	2	16,00	80x22x11,0		249,31	45x14	176,77		
M 18x2,50	3	15,50	95x40x11,0		208,02	45x18	122,43		
M 20x2,00	2	18,00	80x22x12,0		264,09	45x14	175,83		
M 20x2,50	3	17,50	95x40x12,0		233,36	45x18	120,52		
M 22x2,00	2	20,00	80x22x14,5		343,19	55x16	226,56		
M 22x2,50	3	19,50	100x40x14,5		310,83	55x22	181,09		
M 24x2,00	2	22,00	90x22x14,5		409,22	55x16	230,87		
M 24x3,00	3	21,00	110x50x14,5		370,76	55x22	181,09		
M 27x2,00	2	25,00	90x22x16,0		567,14	65x18	341,19		
M 27x3,00	3	24,00	110x50x16,0		468,84	65x25	274,71		
M 30x3,00	2	27,00	125x56x18,0		601,23	65x25	387,26		
M 30x3,50	3	26,50	125x50x18,0		603,20	65x25	275,41		
M 33x2,00	2	31,00	100x25x20,0		857,69	65x18	478,36		
M 33x3,50	3	29,50	125x50x20,0		757,43	65x25	280,69		
M 36x3,00	2	33,00	125x33x22,0		1.384,72	65x25	330,06		
M 36x4,00	3	32,00	150x53x22,0		975,16	65x25	286,16		
M 39x3,00	2	36,00	125x33x24,0		1.197,21	75x30	517,07		
M 39x4,00	3	35,00	150x53x24,0		1.091,14	75x30	435,26		

Consulte otras medidas disponibles bajo demanda

**MACHO Nº3 PARA ROSCAR A MANO, ROSCA METRICA, A IZQUIERDA Y DERECHA**

**M  
MF**

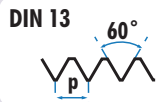

**HSS**

**DIN  
352**

**TOL  
6H**

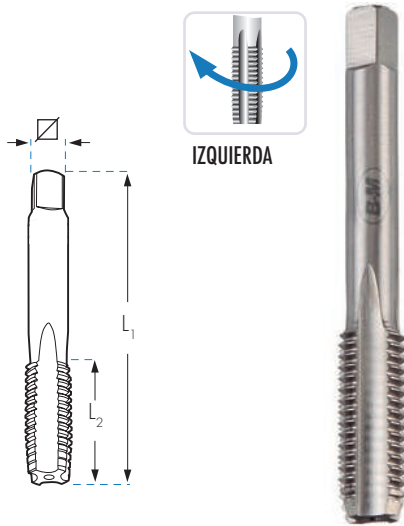

**IZQUIERDA**



**DERECHA**

**D  
MANGO  
DELGADO**

**DIN  
352**

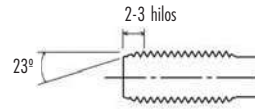

Ref. M03: Cono de entrada 2-3 hilos

		M03I	
		L <sub>1</sub> x L <sub>2</sub> x D <sub>2</sub> x	€
mm			
M 3x0,50	2,50	D 40 x 11 x 3,50 x 2,70	14,72
M 4x0,70	3,30	D 45 x 13 x 4,50 x 3,40	14,71
M 5x0,80	4,20	D 50 x 16 x 6,00 x 4,90	15,72
M 6x1,00	5,00	D 50 x 19 x 6,00 x 4,90	15,72
M 7x1,00	6,00	D 50 x 19 x 6,00 x 4,90	19,15
M 8x1,25	6,75	D 56 x 22 x 6,00 x 4,90	19,14
M 10x1,50	8,50	D 70 x 24 x 7,00 x 5,50	23,60
M 12x1,75	10,20	D 75 x 29 x 9,00 x 7,00	33,19
M 14x2,00	12,00	D 80 x 30 x 11,00 x 9,00	36,72
M 16x2,00	14,00	D 80 x 32 x 12,00 x 9,00	52,54
M 18x2,50	15,50	D 95 x 40 x 14,00 x 11,00	69,34
M 20x2,50	17,50	D 95 x 40 x 16,00 x 12,00	77,79

Consulte otras medidas disponibles bajo demanda

		M03	
		L <sub>1</sub> x L <sub>2</sub> x D <sub>2</sub> x	€
mm			
M 3x0,50	2,50	D 40 x 11 x 3,50 x 2,70	7,36
M 4x0,70	3,30	D 45 x 13 x 4,50 x 3,40	7,35
M 5x0,80	4,20	D 50 x 16 x 6,00 x 4,90	7,86
M 6x1,00	5,00	D 50 x 19 x 6,00 x 4,90	7,86
M 7x1,00	6,00	D 50 x 19 x 6,00 x 4,90	9,58
M 8x1,00	7,00	D 56 x 18 x 6,00 x 4,90	13,25
M 8x1,25	6,75	D 56 x 22 x 6,00 x 4,90	9,57
M 9x1,25	7,75	D 63 x 18 x 7,00 x 5,50	15,67
M 10x1,00	9,00	D 63 x 18 x 7,00 x 5,50	14,19
M 10x1,25	8,80	D 70 x 24 x 7,00 x 5,50	14,38
M 10x1,50	8,50	D 70 x 24 x 7,00 x 5,50	11,80
M 12x1,00	11,00	D 70 x 20 x 9,00 x 7,00	25,16
M 12x1,25	10,75	D 70 x 20 x 9,00 x 7,00	25,08
M 12x1,50	10,50	D 70 x 20 x 9,00 x 7,00	21,37
M 12x1,75	10,20	D 75 x 29 x 9,00 x 7,00	16,60
M 14x1,00	13,00	D 70 x 20 x 11,00 x 9,00	39,21
M 14x1,25	12,80	D 70 x 20 x 11,00 x 9,00	30,63
M 14x1,50	12,50	D 70 x 20 x 11,00 x 9,00	23,82
M 14x2,00	12,00	D 80 x 30 x 11,00 x 9,00	18,36
M 16x1,00	15,00	D 70 x 20 x 12,00 x 9,00	52,02
M 16x1,25	14,75	D 70 x 20 x 12,00 x 9,00	54,75
M 16x1,50	14,50	D 70 x 20 x 12,00 x 9,00	29,64
M 16x2,00	14,00	D 80 x 32 x 12,00 x 9,00	26,27
M 18x1,50	16,50	D 80 x 22 x 14,00 x 11,00	39,05
M 18x2,50	15,50	D 95 x 40 x 14,00 x 11,00	34,67
M 20x1,50	18,50	D 80 x 22 x 16,00 x 12,00	48,90
M 20x2,50	17,50	D 95 x 40 x 16,00 x 12,00	38,89
M 22x2,50	19,50	D 100 x 40 x 18,00 x 14,50	51,81
M 24x3,00	21,00	D 110 x 50 x 18,00 x 14,50	61,79
M 27x3,00	24,00	D 110 x 50 x 20,00 x 16,00	78,14
M 30x3,50	26,50	D 125 x 50 x 22,00 x 18,00	100,53

**GALGAS PARA LA COMPROBACIÓN DE PASOS DE ROSCAS**

	TIPOS DE ROSCA	RANGO DE PASOS		GAM
		Métricos	Ingleses	€
GAM	Pasos rosca métrica	0,25 - 2,5		11,91
GAMW	Pasos rosca métrica /rosca Inglesa	0,25 - 6,0	62h - 4h	21,58

**CONJUNTO DE GUIAS PARA COJINETES M3-M12**

CG5  
M3-M12  
**14,42 €**

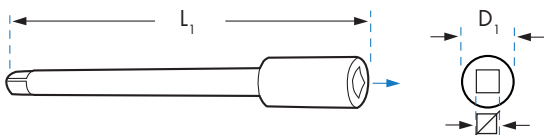
**ALARGADOR DE MACHOS**
**DIN  
377**
**DIN 10**

Misma medida de cuadradillo tanto en zona macho como hembra

	$\square \times L_1$ mm	D <sub>1</sub>	AL €
AL21	2,1 x 60	6,0	8,63
AL24	2,4 x 70	6,0	8,63
AL27	2,7 x 80	7,0	8,63
AL30	3,0 x 90	7,0	8,63
AL34	3,4 x 95	8,0	9,36
AL38	3,8 x 95	9,0	9,77
AL43	4,3 x 105	10,0	10,88
AL49	4,9 x 110	11,0	10,89
AL55	5,5 x 115	12,0	10,96
AL62	6,2 x 120	14,0	13,35
AL70	7,0 x 125	15,0	13,91
AL80	8,0 x 125	17,0	17,37
AL90	9,0 x 135	19,0	17,84

	$\square \times L_1$ mm	D <sub>1</sub>	AL €
AL100	10,0 x 140	21,0	24,65
AL110	11,0 x 150	23,0	24,99
AL120	12,0 x 160	25,0	26,91
AL130	13,0 x 165	27,0	42,10
AL145	14,5 x 175	29,0	42,69
AL160	16,0 x 185	30,0	45,17
AL180	18,0 x 195	33,0	51,47
AL200	20,0 x 220	36,0	68,65
AL220	22,0 x 220	40,0	100,33
AL240	24,0 x 235	42,0	153,66
AL260	26,0 x 245	45,0	162,25
AL290	29,0 x 260	55,0	187,20
AL320	32,0 x 280	55,0	230,45



**GIRAMACHOS DE ACERO FORJADO**

Máxima Resistencia  
150 kg/mm<sup>2</sup>

Ref. GAPRO

- Cuerpo de Acero Forjado.
- Soporta esfuerzos hasta 150 kg/mm<sup>2</sup>.
- Máxima resistencia y durabilidad.

- Mayor precisión y firmeza en el amarre.
- Su rosca de precisión conforma un conjunto sólido y robusto.
- Maneral antideslizante, mayor agarre en el taller.



GAPRO

Nº NORMA	Nº 0	Nº 1	Nº 1.1/2	Nº 2	Nº 3	Nº 4	Nº 5
	M1-M8 2,00-5,00	M1-M10 2,00-6,30	M1-M12 2,50-7,00	M1-M12 2,50-8,00	M5-M20 4,00-13,00	M5-M27 4,00-16,00	M9-M32 5,50-20,00
€	21,41	22,62	24,04	30,38	42,99	68,74	145,49

Ref. GA

- Cuerpo de Aleación de Zinc.
- Alta resistencia y durabilidad.
- Alta precisión y firmeza en el amarre.



GA

Nº NORMA	Nº 0	Nº 1	Nº 1.1/2	Nº 2	Nº 3	Nº 4	Nº 5	Nº 7	Nº 8
	M1-M8 1,50-5,00	M1-M10 2,00-7,00	M1-M12 2,00-8,00	M4-M12 2,50-10,00	M5-M20 3,50-14,00	M9-M27 4,00-15,00	M13-M32 5,50-19,00	M22-M52 14,00-34,00	M33-M64 16,00-40,00
€	17,99	19,02	20,20	25,52	36,12	57,77	122,26	241,52	394,59

**VOLVEDORES PARA TERRAJAS DE ROSCAR**

Ref. VA

DIN  
225



5

IMPORTANTE: A la hora de cursar sus pedidos de volvedores, indiquen el espesor del volvedor que corresponda, según detalle de espesores que indicamos en la tarifa de terrajas.

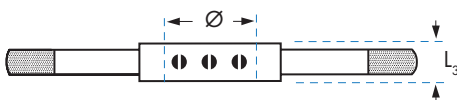

Ø x L3 mm	16x5	20x5	20x7	25x9	30x11	38x10	38x14	45x14	45x18	55x16	55x22	65x18	65x25
€	9,99	11,06	11,06	12,62	15,29	19,99	19,96	24,54	24,72	31,72	33,22	45,45	45,45
Ø x L3 mm	75x20	75x30	90x22	90x36	105x22	105x36	120x22	120x36	130x25	130x36	140x25		
€	78,75	82,43	99,75	107,47	148,41	148,41	385,98	385,98	401,27	401,27	421,98		

VA

Ref. VA

PULGADAS



3



Ø mm	20,60	25,40	38,10	50,80	63,50	76,20	88,90
PULGADAS	13/16"	1"	1.1/2"	2"	2.1/2"	3"	3.1/2"
€	10,83	12,85	19,23	28,52	45,01	83,23	105,43

VA

NOTA: Los volvedores para terrajas en Ø exteriores en pulgadas, están en desuso.

## GIRAMACHOS EN T CON CRIQUE

Ref. TC

**TIPO**  
**T**

SERIE CORTA



	CAPACIDAD mm mín.-máx.	Para mangos de machos		L <sub>1</sub> mm	PESO g	CALIDAD	TC
		DIN	ISO				€
TC3B	2,6 - 5,5	M3 - 8	M3 - 6	85	180	1ª Calidad	29,38
TC4B	4,6 - 8,0	M5 - 12	M6 - 12	110	300	1ª Calidad	39,70
TC1B	2,6 - 5,5	M3 - 8	M3 - 6	85	180	2ª Calidad	22,25
TC2B	4,6 - 8,0	M5 - 12	M6 - 12	110	300	2ª Calidad	29,84

Ref. TL

**TIPO**  
**T**

SERIE LARGA



	CAPACIDAD mm mín.-máx.	Para mangos de machos		L <sub>1</sub> mm	PESO g	CALIDAD	TL
		DIN	ISO				€
TL3	2,6 - 5,5	M3 - 8	M3 - 6	250	250	1ª Calidad	44,69
TL4	4,6 - 8,0	M5 - 12	M6 - 12	300	440	1ª Calidad	53,20
TL1	2,6 - 5,5	M3 - 10	M3 - 6	250	250	2ª Calidad	35,29
TL2	4,6 - 8,0	M5 - 12	M6 - 12	300	440	2ª Calidad	42,05

## EXPOSITOR DE METACRILATO

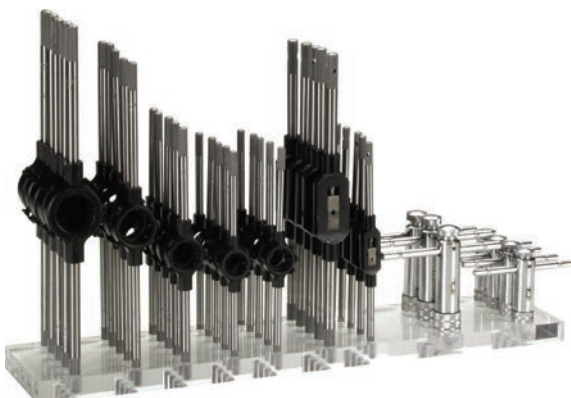

Dimensiones: 500 x 320 x 110 mm

				GV-01
				€
GV-01	Nº 1 1/2 5	Nº 2 5	20x5 20x7 25x9 5 5 5 30x11 38x14 5 5	TC1 TC2 4 4 773,85

**CONJUNTOS DE MACHOS Y COJINETES EN CAJA METÁLICA HSS**



**M3  
M12**

**HSS**



Ref. D624

**CONTENIDO**

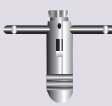
					Nº Piezas	1º Calidad €	2º Calidad €
D624	M3 - M4 - M5 - M6 - M8 - M10 - M12	Nº 1.1/2	25 x 9	-	30	250,75	227,47

**CONJUNTOS DE COJINETES EN CAJA METÁLICA HSS**



**M3  
M12**

**HSS**



Ref. D671

**CONTENIDO**

				Nº Piezas	1º Calidad €	2º Calidad €	
D671	M3 - M4 - M5 - M6 - M8 - M10 - M12	20 x 5 30 x 11	20 x 7 38 x 14	25 x 9	12	247,34	209,50
D671I (Izq)	 M3 - M4 - M5 - M6 - M8 - M10 - M12	20 x 5 30 x 11	20 x 7 38 x 14	25 x 9	12	494,67	418,97

**CONJUNTOS DE MACHOS Y COJINETES EN CAJA METÁLICA HSS Y HSSCo**
**M3  
M12**

**HSS**
**HSSCo  
5%**

Ref. D621



Ref. D655

**CONTENIDO**

						Nº Piezas	1ª Calidad €	2ª Calidad €
D621	M3 - M4 - M5 - M6 M8 - M10 - M12	2.5 / 3.3 / 4.2 / 5.0 6.8 / 8.5 / 10.2 mm	Nº 1 Nº 2	20 x 5 20 x 7 25 x 9 30 x 11 38 x 14	TC1	43	502,79	368,52
D652	M3 - M4 - M5 - M6 M8 - M10 - M12	2.5 / 3.3 / 4.2 / 5.0 6.8 / 8.5 / 10.2 mm	Nº 1 Nº 2	20 x 5 20 x 7 25 x 9 30 x 11 38 x 14	-	42	486,69	349,96
D662	M3-M4-M5-M6-M7 M8-M9-M10-M11-M12	-	Nº 1 Nº 2	20 x 5 20 x 7 25 x 9 30 x 11 38 x 14	TC1	48	749,01	658,81
D651	M3 - M4 - M5 - M6 M8 - M10 - M12	-	Nº 1 Nº 2	20 x 5 20 x 7 25 x 9 30 x 11 38 x 14	-	35	384,13	353,39
D655* (HSSCo)	M3 - M4 - M5 - M6 M8 - M10 - M12	2.5 / 3.3 / 4.2 / 5.0 6.8 / 8.5 / 10.2 mm	Nº 1 Nº 2	20 x 5 20 x 7 25 x 9 30 x 11 38 x 14	TC1	43	802,08	705,53
D621I (Izq)	M3 - M4 - M5 - M6 M8 - M10 - M12	2.5 / 3.3 / 4.2 / 5.0 6.8 / 8.5 / 10.2 mm	Nº 1 Nº 2	20 x 5 20 x 7 25 x 9 30 x 11 38 x 14	TC1	43	785,25	684,80

\*

**HSSCo  
5%**

**CONJUNTOS DE MACHOS Y COJINETES EN CAJA METÁLICA HSS Y HSSCo CON GUÍAS PARA COJINETES**

**M3  
M12**



**HSS**

**HSSCo  
5%**



Ref. D656



GUÍAS



Ref. D657

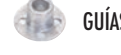

GUÍAS

**CONTENIDO**

							Nº Piezas	1ª Calidad €	2ª Calidad €
	M3 - M4 - M5 - M6 M8 - M10 - M12	2.5 / 3.3 / 4.2 / 5.0 6.8 / 8.5 / 10.2 mm	Nº 1 Nº 2	+ GUÍAS	20x5 20x7 25x9 30x11 38x14	TC1	43	561,85	497,37
D656	M3 - M4 - M5 - M6 M8 - M10 - M12	2.5 / 3.3 / 4.2 / 5.0 6.8 / 8.5 / 10.2 mm	Nº 1 Nº 2	+ GUÍAS	20x5 20x7 25x9 30x11 38x14	TC1	43	561,85	497,37
D657* (HSSCo)	M3 - M4 - M5 - M6 M8 - M10 - M12	2.5 / 3.3 / 4.2 / 5.0 6.8 / 8.5 / 10.2 mm	Nº 1 Nº 2	+ GUÍAS	20x5 20x7 25x9 30x11 38x14	TC1	43	836,41	738,24

\* **HSSCo 5%**

**CONJUNTOS DE MACHOS Y COJINETES EN CAJA METÁLICA HSS Y HSSCo**
**M3  
M20**
**M5  
M20**
**HSS**
**HSSCo  
5%**

Ref. D622



Ref. D623

**CONTENIDO**

						Nº Piezas	1ª Calidad €	2ª Calidad €
D622	M3 - M4 - M5 - M6 - M8 - M10 - M12 M14 - M16 - M18 - M20	Nº 1 Nº 3	20 x 5   20 x 7   25 x 9 30 x 11   38 x 14   45 x 18		TC1 TC2	54	859,95	675,64
D658	M3 - M4 - M5 - M6 - M8 - M10 - M12 M14 - M16 - M18 - M20	Nº 1 Nº 3	20 x 5   20 x 7   25 x 9 30 x 11   38 x 14   45 x 18		-	52	792,21	611,27
D622I (Izq)	M3 - M4 - M5 - M6 - M8 - M10 - M12 M14 - M16 - M18 - M20	Nº 1 Nº 3	20 x 5   20 x 7   25 x 9 30 x 11   38 x 14   45 x 18		TC1 TC2	54	1.480,89	-
D659* (HSSCo)	M3 - M4 - M5 - M6 - M8 - M10 - M12 M14 - M16 - M18 - M20	Nº 1 Nº 3	20 x 5   20 x 7   25 x 9 30 x 11   38 x 14   45 x 18		-	52	1.786,29	1.571,22
D623	M5 - M6 - M8 - M10 - M12 M14 - M16 - M18 - M20	Nº 1 Nº 3	20 x 7   25 x 9 30 x 11   38 x 14   45 x 18		TC1 TC2	45	901,60	705,86
D663	M5 - M6 - M7 - M8 - M9 - M10 - M12 M14 - M16 - M18 - M20	Nº 1 Nº 3	20 x 7   25 x 9   30 x 11 38 x 14   45 x 18		-	51	1.202,03	1.081,20

\*

**HSSCo  
5%**

**CONJUNTOS DE MACHOS Y COJINETES EN CAJA METÁLICA Y DE MADERA HSS**

**M1  
M10**

**M5  
M12**

**M3  
M24**

**M5  
M30**

**HSS**





Ref. D628

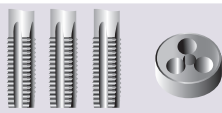

Ref. D626

**CONTENIDO**

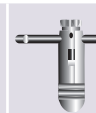
					Nº Piezas	1ª Calidad €	2ª Calidad €
D626	M1 - M1.2 - M1.4 - M1.7 - M2.0 - M2.3 M2.6 - M3 - M3.5 - M4 - M5 - M6 - M8 - M10	Nº 0 Nº 1	16 x 5   20 x 5   20 x 7 25 x 9   30 x 11	TC1	64	-	1.124,71
D627	M5 - M6 - M7 - M8 - M9 - M10 - M11 - M12	Nº 1 Nº 2	20 x 7   25 x 9 30 x 11   38 x 14	TC1	39	-	840,21
D625	M3 - M4 - M5 - M6 - M8 - M10 - M12 - M14 M16 - M18 - M20 - M22 - M24	Nº 1 Nº 4	20 x 5   20 x 7   25 x 9 30 x 11   38 x 14   45 x 18   55 x 22	-	61	1.984,50	1.464,24
D628	M5 - M6 - M8 - M10 - M12 - M14 - M16 M18 - M20 - M22 - M24 - M27 - M30	Nº 1 Nº 3 Nº 5	20 x 7   25 x 9   30 x 11 38 x 14   45 x 18   55 x 22 65 x 25	-	62	-	2.680,11





**CONJUNTOS DE MACHOS Y COJINETES EN CAJA METÁLICA HSS**
**MF**
**HSS**

Ref. D634

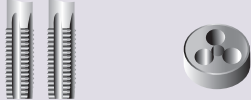

Ref. D636

**CONTENIDO**

					Nº Piezas	1ª Calidad €	2ª Calidad €
D634	MF 3 x 0.35 - 4 x 0.5 - 5 x 0.5 MF 6 x 0.75 - 8 x 0.75 - 8 x 1.0 MF 10 x 1.0 - 12 x 1.5	Nº 1 Nº 2	20 x 5 25 x 9 30 x 11 38 x 10	TC1	31	-	770,87
D635	MF 6 x 0.75 - 8 x 0.75 - 8 x 1.0 - 10 x 1.0 MF 12 x 1.0 - 12 x 1.5 - 14 x 1.25 - 14 x 1.5 MF 16 x 1.5 - 18 x 1.5 - 20 x 1.5	Nº 1 Nº 3	20 x 7 25 x 9 30 x 11 38 x 10 45 x 14	-	40	1.257,45	1.195,74
D636	MF 6 x 0.75 - 8 x 0.75 - 8 x 1.0 - 10 x 1.0 MF 12 x 1.0 - 12 x 1.5 - 14 x 1.25 - 14 x 1.5 MF 16 x 1.5 - 18 x 1.5 - 20 x 1.5 - 22 x 1.5 MF 24 x 1.5	Nº 1 Nº 4	20 x 7 25 x 9 30 x 11 38 x 10 45 x 14 55 x 16	-	47	1.724,99	1.594,87



**CONJUNTOS DE MACHOS Y COJINETES EN CAJA METÁLICA HSS**



Ref. D638

**CONTENIDO**

						Nº Piezas	1ª Calidad €	2ª Calidad €
D637	G 1/8 - 1/4 - 3/8 - 1/2 - 3/4 - 1"	Nº 1 Nº 3 Nº 5	30 x 11 38 x 10 45 x 14 55 x 16 65 x 18	-	26	1.396,16	1.127,80	
D638	G 1/8 - 1/4 - 3/8 - 1/2 - 5/8 - 3/4 - 7/8 - 1"	Nº 1 Nº 3 Nº 5	30 x 11 38 x 10 45 x 14 55 x 16 65 x 18	-	32	1.894,73	1.653,96	
D639	G 1/4 - 3/8 - 1/2 - 3/4 - 1" - 1".1/4 - 1".1/2	Nº 2 Nº 4 Nº 7	38 x 10 45 x 14 55 x 16 65 x 18 75 x 20 90 x 22	-	30	3.495,46	2.948,56	

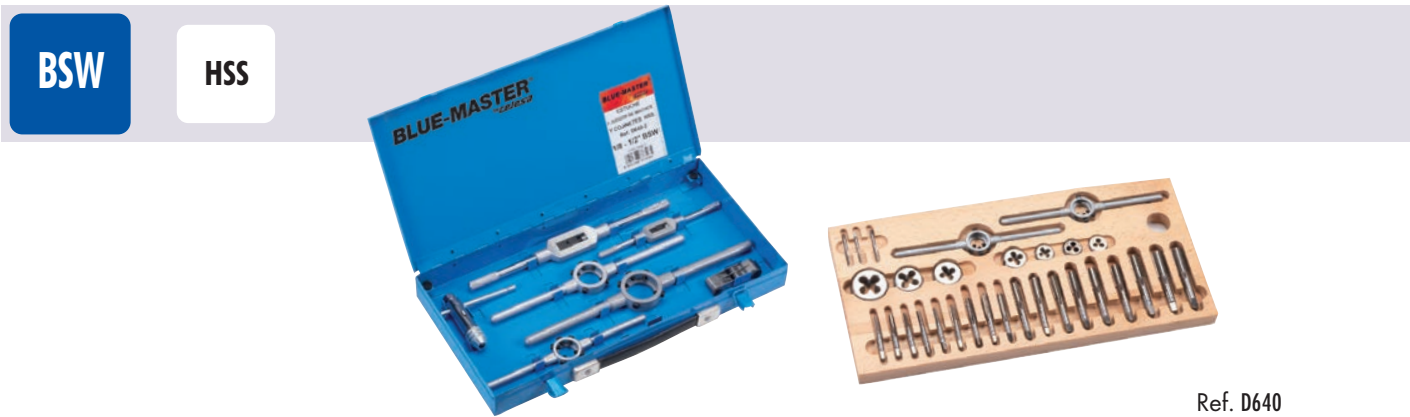

Ref. D640





**CONTENIDO**

						Nº Piezas	1ª Calidad €	2ª Calidad €
D640	BSW 1/8 - 3/16 - 1/4 - 5/16 - 3/8 - 7/16 - 1/2	Nº 1 Nº 2	20 x 5 20 x 7 25 x 9 30 x 11 38 x 14	TC1	36	778,86	665,81	
D641	BSW 1/4 - 5/16 - 3/8 - 7/16 - 1/2	Nº 1 Nº 2	20 x 7 25 x 9 30 x 11 38 x 14	TC1	27	642,07	540,80	
D642	BSW 1/4 - 5/16 - 3/8 - 7/16 - 1/2 - 5/8 - 3/4	Nº 1 Nº 3	20 x 7 25 x 9 30 x 11 38 x 14 45 x 18	-	35	1.149,07	1.048,48	
D643	BSW 1/4 - 5/16 - 3/8 - 7/16 1/2 - 5/8 - 3/4 - 7/8 - 1"	Nº 1 Nº 4	20 x 7 25 x 9 30 x 11 38 x 14 45 x 18 55 x 22	-	44	1.625,05	1.426,74	
D646	BSW 1/4 - 5/16 - 3/8 - 7/16 1/2 - 5/8 - 3/4 - 7/8 - 1" - 1".1/8 1".1/4 - 1".3/8 - 1".1/2	Nº 1 Nº 3 Nº 5	20 x 7 25 x 9 30 x 11 38 x 14 45 x 18 55 x 22 65 x 25	-	62	-	4.335,52	

**CONJUNTOS DE MACHOS Y COJINETES EN CAJA METÁLICA HSS**
**BSF**
**HSS**

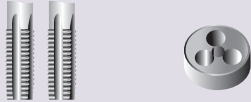
Ref. D648





**CONTENIDO**

					Nº Piezas	1ª Calidad €	2ª Calidad €
D664	BSF 1/4 - 5/16 - 3/8 - 7/16 - 1/2	Nº 1 Nº 2	20 x 7 25 x 9 30 x 11 38 x 10	TC1	22	718,02	631,56
D648	BSF 1/4 - 5/16 - 3/8 - 7/16 - 1/2 - 5/8 - 3/4	Nº 1 Nº 3	20 x 7 25 x 9 30 x 11 38 x 10 45 x 14	-	28	1.114,65	1.048,48
D665	BSF 1/4 - 5/16 - 3/8 - 7/16 1/2 - 5/8 - 3/4 - 7/8 - 1"	Nº 1 Nº 4	20 x 7 25 x 9 30 x 11 38 x 10 45 x 14 55 x 16	-	35	1.891,38	1.663,64

**BSW  
BSF**
**HSS**

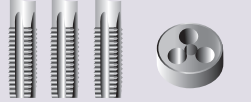
Ref. D666

**CONTENIDO**





					Nº Piezas	1ª Calidad €	2ª Calidad €
D666	BSW 1/4 - 5/16 - 3/8 - 7/16 - 1/2 - 5/8 - 3/4 BSF 1/4 - 5/16 - 3/8 - 7/16 - 1/2 - 5/8 - 3/4	Nº 1 Nº 3	20 x 7 25 x 9 30 x 11 38 x 14 45 x 18	-	63	2.136,56	1.879,30

**CONJUNTOS DE MACHOS Y COJINETES EN CAJA METÁLICA HSS**



Ref. D660





**CONTENIDO**

						Nº Piezas	1ª Calidad €	2ª Calidad €
D660	NPT 1/8 - 1/4 - 3/8 - 1/2 - 3/4 - 1"		Nº1 Nº3 Nº5	30 x 11 38 x 14 45 x 18 55 x 22 65 x 25	-	20	2.019,60	1.915,69
D661	NPT 1/8 - 1/4 - 3/8 - 1/2 - 3/4 1" - 1.1/4 - 1.1/2 - 2"		Nº 2 Nº 4 Nº 7	30 x 11 38 x 14 45 x 18 55 x 22 65 x 25 75 x 30 90 x 36 105 x 36	-	29	6.045,65	5.679,86

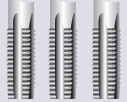

Ref. D650

**CONTENIDO**

						Nº Piezas	1ª Calidad €	2ª Calidad €
D650	UNC 1/4 - 5/16 - 3/8 - 7/16 - 1/2		Nº 1 Nº 2	20 x 7 25 x 9 30 x 11 38 x 14	TC1	27	782,61	702,43
D667	UNC 1/4 - 5/16 - 3/8 - 7/16 - 1/2 - 5/8 - 3/4		Nº 1 Nº 2	20 x 7 25 x 9 30 x 11 38 x 14 45 x 18	-	35	1.260,92	1.109,09
D654	UNC 1/4 - 5/16 - 3/8 - 7/16 1/2 - 5/8 - 3/4 - 7/8 - 1"		Nº 1 Nº 4	20 x 7 25 x 9 30 x 11 38 x 14 45 x 18 55 x 22	-	44	2.034,61	1.904,14
D668	UNC 1/4 - 5/16 - 3/8 - 7/16 - 1/2 - 5/8 - 3/4 7/8 - 1" - 1.1/8 - 1.1/4 - 1.3/8 - 1.1/2"		Nº 1 Nº 3 Nº 6	20 x 7 25 x 9 30 x 11 38 x 14 45 x 18 55 x 22 65 x 25	-	62	4.763,45	4.189,89

**CONJUNTOS DE MACHOS Y COJINETES EN CAJA METÁLICA HSS**



UNF

HSS



Ref. D644

**CONTENIDO**

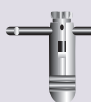
					Nº Piezas	1ª Calidad €	2ª Calidad €
D644	UNF 1/4 - 5/16 - 3/8 - 7/16 - 1/2	Nº 1 Nº 2	20 x 7 25 x 9 30 x 11 38 x 10	TC1	22	613,25	531,63
D669	UNF 1/4-5/16-3/8-7/16-1/2-5/8-3/4	Nº 1 Nº 3	20 x 7 25 x 9 30 x 11 38 x 10 45 x 14	-	28	1.155,83	1.016,66
D645	UNF 1/4 - 5/16 - 3/8 - 7/16 - 1/2 - 5/8 3/4 - 7/8 - 1"	Nº 1 Nº 4	20 x 7 25 x 9 30 x 11 38 x 10 45 x 14 55 x 16	-	34	1.417,28	1.285,05

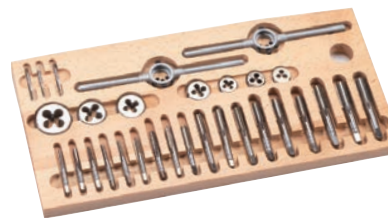

UNC  
UNF

HSS

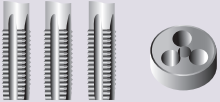

Ref. D670

**CONTENIDO**

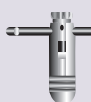
					Nº Piezas	1ª Calidad €	2ª Calidad €
D670	UNC 1/4 - 5/16 - 3/8 - 7/16 - 1/2 - 5/8 - 3/4 UNF 1/4 - 5/16 - 3/8 - 7/16 - 1/2 - 5/8 - 3/4	Nº 1 Nº 3	20 x 7 25 x 9 30 x 11 38 x 14 45 x 18	-	35	2.136,56	1.879,30

**JUEGOS DE MACHOS DE MANO HSS Y TiN EN ESTUCHES METÁLICOS**



Ref. JMB0



Ref. JMB2



Ref. JMBT2

**CONTENIDO**

					HSS €		TiN* €
JMB2	M3 - M4 - M5 - M6 M8 - M10 - M12	-	-	-	198,53	JMBT2	394,19
JMB0	M3 - M4 - M5 - M6 M8 - M10 - M12	2.5 / 3.3 / 4.2 / 5.0 6.8 / 8.5 / 10.2 mm	-	-	226,46	JMBT0	442,36
JMB1	M3 - M4 - M5 - M6 M8 - M10 - M12	2.5 / 3.3 / 4.2 / 5.0 6.8 / 8.5 / 10.2 mm	Nº 1.1/2	-	243,73	JMBT1	379,06
JMB5	M3 - M4 - M5 - M6 M8 - M10 - M12	2.5 / 3.3 / 4.2 / 5.0 6.8 / 8.5 / 10.2 mm	Nº 1.1/2	TC1	258,87	JMBT5	397,19
JMBI2 (Izq)	M3 - M4 - M5 - M6 M8 - M10 - M12	-	-	-	368,17	JMBIT2	684,78
JMBI0 (Izq)	M3 - M4 - M5 - M6 M8 - M10 - M12	2.5 / 3.3 / 4.2 / 5.0 6.8 / 8.5 / 10.2 mm	-	-	426,50	JMBIT0	742,74
JMBI1 (Izq)	M3 - M4 - M5 - M6 M8 - M10 - M12	2.5 / 3.3 / 4.2 / 5.0 6.8 / 8.5 / 10.2 mm	Nº 1.1/2	-	443,15	JMBIT1	758,13

**MACHOS TERCEROS DE MANO HSS Y TiN EN ESTUCHES METÁLICOS**



Ref. JMB3



Ref. JMB4

**CONTENIDO**

3°					HSS €		TiN* €
JMB3	M3 - M4 - M5 - M6 M8 - M10 - M12	-	-	-	91,14	JMBT3	114,13
JMB4	M3 - M4 - M5 - M6 M8 - M10 - M12	2.5 / 3.3 / 4.2 / 5.0 6.8 / 8.5 / 10.2 mm	-	-	113,43	JMBT4	150,77
JMB7	M3 - M4 - M5 - M6 M8 - M10 - M12	2.5 / 3.3 / 4.2 / 5.0 6.8 / 8.5 / 10.2 mm	Nº 1.1/2	-	129,80	JMBT7	209,14
JMB6	M3 - M4 - M5 - M6 M8 - M10 - M12	2.5 / 3.3 / 4.2 / 5.0 6.8 / 8.5 / 10.2 mm	Nº 1.1/2	TC1	140,55	JMBT6	222,91
JMBI3 (Izq)	M3 - M4 - M5 - M6 M8 - M10 - M12	-	-	-	122,71	JMBIT3	228,25
JMBI4 (Izq)	M3 - M4 - M5 - M6 M8 - M10 - M12	2.5 / 3.3 / 4.2 / 5.0 6.8 / 8.5 / 10.2 mm	-	-	164,44	JMBIT4	302,56



**MACHOS DE MANO HSSCo EN ESTUCHES METÁLICOS**
**HSSCo**  
**5%**

Ref. JMBX0

**CONTENIDO**

INOX	 MOX	 HSSCo			€
JMBX0	M3 - M4 - M5 - M6 M8 - M10 - M12	2.5 / 3.3 / 4.2 / 5.0 6.8 / 8.5 / 10.2 mm	-	-	312,94
JMBX1	M3 - M4 - M5 - M6 M8 - M10 - M12	2.5 / 3.3 / 4.2 / 5.0 6.8 / 8.5 / 10.2 mm	Nº 1.1/2	-	329,35
JMBX2	M3 - M4 - M5 - M6 M8 - M10 - M12	-	-	-	295,92

**CONTENIDO**

 1100 N/mm <sup>2</sup>	 MOMD	 HSSCo			€
JMBMD0	M3 - M4 - M5 - M6 M8 - M10 - M12	2.5 / 3.3 / 4.2 / 5.0 6.8 / 8.5 / 10.2 mm	-	-	326,82
JMBMD1	M3 - M4 - M5 - M6 M8 - M10 - M12	2.5 / 3.3 / 4.2 / 5.0 6.8 / 8.5 / 10.2 mm	Nº 1.1/2	-	343,82
JMBMD2	M3 - M4 - M5 - M6 M8 - M10 - M12	-	-	-	311,53

**ESTUCHES DE COJINETES EN CAJAS METÁLICAS HSS**

Ref. C5B3

**CONTENIDO**

		HSS €
C5B3	M3 - M4 - M5 - M6 - M8 - M10 - M12	237,19
C5B31 (Izda.)	M3 - M4 - M5 - M6 - M8 - M10 - M12	469,78

**EXTRACTOR DE MACHOS ROTOS PARA MACHOS DE CANALES RECTOS - NO HELICOIDALES**



**EXTRACTORES SUELTOS**

Ø MACHO A EXTRAER		MACHOS DE MANO	MACHOS DE MÁQUINA	€/ Ud.
BSW UNC	M			EXTRACTOR COMPLETO
--	M3		W10043	45,23
1/8	M3,2		W10053	45,23
--	M3,5		W10063	45,23
5/32	M4		W10083	45,23
3/16	M5		W10103	45,23
--	M5,5	W10124	W10123	45,23
1/4	M6	W10254	W10253	46,56
5/16	M8	W10314	W10313	48,79
--	M9	W10374	W10373	48,33
3/8	M10	W10404	W10373	48,33
7/16	M11	W10434	W10433	51,02
1/2	M12	W10504	W10503	54,55
9/16	M14	W10564	W10563	75,39
5/8	M16	W10624	W10623	82,05
--	M18	W10684	W10753	101,66
3/4	M20	W10754	W10753	101,66
7/8	M22	W10874	W10873	111,24
1"	M25	W11004	W11003	124,05

**VARILLA REPUESTO**

MACHOS DE MANO	MACHOS DE MÁQUINA	€/ Ud.
		VARILLA EXTRA
	W12043	2,41
	W12053	2,41
	W12063	2,41
	W12083	2,41
	W12103	3,59
	W12123	3,59
	W12253	4,38
W12314	W12313	4,94
W12374		4,94
W12404	W12373	5,10
W12434	W12433	5,18
W12504	W12503	6,52
W12564	W12563	7,27
W12624	W12623	9,30
W12684		9,30
W12754	W12753	9,84
W12874	W12873	12,75
W13004	W13003	21,22

**3 SIMPLES PASOS PARA EXTRAER MACHOS DE ROSCAR ROTOS DE CANALES RECTOS**

Sacar toda la viruta del macho roto. Introducir las varillas del extractor en los canales del macho roto con firmeza hasta el fondo.



Empujar el soporte hacia abajo, hasta tocar el macho roto. Deslice el casquillo hacia abajo, hasta tocar la zona de trabajo.



Aplicar al cuadradillo del extractor un gira-machos. Gire a izquierdas unas cuantas veces hasta soltarlo y entonces saque el macho roto.

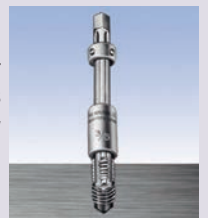

**JUEGOS DE EXTRACTORES PARA MACHOS ROTOS (CANALES RECTOS)**



Nº CANALES	MEDIDAS INCLUIDAS PARA MACHOS DE MÁQUINA Y DE MANO: 3 y 4 CANALES	
W180013	3	M5- M6- M8- M10- M11- M12
W180014	4	3/16 - 1/4 - 5/16 - 3/8 - 7/16 - 1/2
W180023	3	M6- M8 -M10- M11- M12- M16
W180024	4	1/4 - 5/16 - 3/8 - 7/16 - 1/2 - 5/8
W180153	3	M3- M3,2- M3,5- M4-M5- M5,50- M6- M8
W180154	4	M9- M10- M12- M16- M18- M22- M25

313,57

352,79

986,83

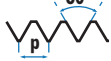
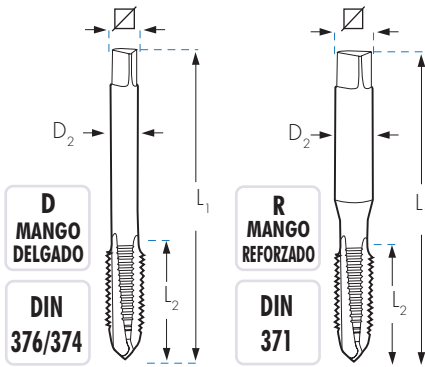
**MACHOS PARA ROSCAR A MÁQUINA HSSCo**
**M  
MF**
**DIN 13**

**HSSCo  
5%**
**TOL  
6H**
**Vc  
12 m/min**









D	MANGO DELGADO	DIN 376/374	R	MANGO REFORZADO	DIN 371	M1D		M2D		M3D		M4D		M1R		M2R		M3R		M4R	
						FORMA C	FORMA B	FORMA C	FORMA B	FORMA C	FORMA B	FORMA C	FORMA B	FORMA C	FORMA B	FORMA C	FORMA B	FORMA C	FORMA B	FORMA C	FORMA B
L1 x L2 x D2 x $\square$ mm						€	€	€	€	€	€	€	€	€	€	€	€	€	€	€	€
M 1x0,25	0,75	R	40 x 5,5 x 2,5 x 2,1											43,34							
M 1,1x0,25	0,85	R	40 x 6 x 2,5 x 2,1											42,16							
M 1,2x0,25	0,95	R	40 x 6 x 2,5 x 2,1											38,51							
M 1,4x0,30	1,10	R	40 x 7 x 2,5 x 2,1											38,51							
M 1,6x0,35	1,25	R	40 x 8 x 2,5 x 2,1											37,82							
M 1,7x0,35	1,35	R	40 x 8 x 2,5 x 2,1											36,42							
M 1,8x0,35	1,45	R	40 x 8 x 2,5 x 2,1											35,52							
M 2x0,40	1,60	R	40 x 8 x 2,8 x 2,1											17,10	18,95	21,19	21,59				
M 2,2x0,45	1,75	R	40 x 9 x 2,8 x 2,1											18,49							
M 2,3x0,40	1,90	R	40 x 9 x 2,8 x 2,1											17,03							
M 2,5x0,45	2,05	R	50 x 9 x 2,8 x 2,1											17,10	18,95	29,79	21,59				
M 2,6x0,45	2,10	R	50 x 9 x 2,8 x 2,1											17,13	19,29					35,89	
M 3x0,50	2,50	R D	56 x 11 x 3,5 x 2,7 56 x 11 x 2,2 x 1,8			11,33	12,27	17,08	14,72					11,33*	11,51	16,74	15,09				
M 3x0,60	2,40	R	56 x 11 x 3,5 x 2,7											20,14	21,98					29,03	
M 3,5x0,60	2,90	R D	56 x 12 x 4,0 x 3,0 56 x 12 x 2,5 x 2,1											16,47	17,14	22,14	20,78				
M 3,5x0,75	2,75	R	56 x 12 x 4,0 x 3,0											21,77							
M 4x0,50	3,50	R D	63 x 13 x 4,5 x 3,4 63 x 13 x 2,8 x 2,1			24,81	27,32		28,89					23,71	26,38					30,54	
M 4x0,70	3,30	R D	63 x 13 x 4,5 x 3,4 63 x 13 x 2,8 x 2,1			11,53	12,40	18,31	14,58					12,89*	12,16	16,52	15,10				
M 4x0,75	3,25	R	63 x 13 x 4,5 x 3,4											18,03	19,25						
M 4x0,80	3,20	R	63 x 13 x 4,5 x 3,4											95,70							
M 4,5x0,50	4,00	R	70 x 14 x 6,0 x 4,9												30,69						
M 4,5x0,75	3,75	R	70 x 14 x 6,0 x 4,9											22,25	24,50						
M 5x0,50	4,50	R D	70 x 14 x 6,0 x 4,9 70 x 11 x 3,5 x 2,7			25,55	28,07		29,21					24,42	27,10					32,58	
M 5x0,75	4,50	R D	74 x 14 x 6,0 x 4,9 70 x 16 x 3,5 x 2,7											21,90	25,69					32,37	
M 5x0,80	4,20	R D	70 x 16 x 6,0 x 4,9 70 x 16 x 3,5 x 2,7			11,53	12,47	17,55	14,00					11,54*	12,18	15,85	14,48				
M 5x0,90	4,10	R D	70 x 15 x 6,0 x 4,9 70 x 16 x 3,5 x 2,7											19,05	24,54						
M 5x1,00	4,00	R	72 x 17 x 6,0 x 4,9											51,02							
M 5,5x0,90	4,60	R	80 x 17 x 6,0 x 4,9											51,02							
M 6x0,50	5,50	R D	80 x 17 x 6,0 x 4,9 80 x 13 x 4,5 x 3,4			30,25	37,09		46,80					31,97							
M 6x0,75	5,25	R D	80 x 13 x 6,0 x 4,9 80 x 13 x 4,5 x 3,4			19,93	23,08		26,95					20,71	24,13					28,98	
M 6x1,00	5,00	R D	80 x 19 x 6,0 x 4,9 80 x 19 x 4,5 x 3,4			13,15	13,66	18,36	15,35					13,13*	13,36	17,39	15,88				

\* Consulte el precio de machos y terrajas a izquierdas disponibles en Pag.217



**MACHOS PARA ROSCAR A MÁQUINA HSSCo**





**M MF** **DIN 13**  **HSSCo 5%** **TOL 6H** **D MANGO DELGADO** **DIN 376/374** **Vc 12 m/min** **R MANGO REFORZADO** **DIN 371**

		L1 x L2 x D2 x  mm	M1D	M2D	M3D	M4D	M1R	M2R	M3R	M4R
			FORMA C €	FORMA B €	 15° €	 35° €	FORMA C €	FORMA B €	 15° €	 35° €
M 6x1,25	4,75	R 80 x 17 x 6,0 x 4,9					50,15			
M 7x0,75	6,25	D 80 x 13 x 5,5 x 4,3	25,66	28,46		35,15				
<b>M 7x1,00</b>	<b>6,00</b>	R 80 x 19 x 7,0 x 5,5 D 80 x 19 x 5,5 x 4,3	17,69	20,45	22,09	21,26	17,03*	19,88	22,48	22,25
M 8x0,50	7,50	D 80 x 13 x 6 x 4,9	34,51							
M 8x0,75	7,25	D 80 x 13 x 6 x 4,9	25,00	30,66		38,02				
M 8x1,00	7,00	D 90 x 20 x 6 x 4,9	20,45	23,47	28,12	26,00				
<b>M 8x1,25</b>	<b>6,80</b>	R 90 x 22 x 8 x 6,2 D 90 x 22 x 6 x 4,9	14,75	15,41	20,90	17,92	14,84*	14,85	20,02	18,14
M 8x1,50	6,50	D 90 x 20 x 6 x 4,9	101,14							
M 9x1,00	8,00	D 90 x 20 x 7 x 5,5	30,92	33,06		35,13				
<b>M 9x1,25</b>	<b>7,80</b>	R 90 x 22 x 9 x 7,0 D 90 x 22 x 7 x 5,5	24,85	26,11	31,62	30,91	24,61	24,93	31,88	31,80
M 10x0,50	9,50	D 90 x 20 x 7 x 5,5	100,21							
M 10x0,75	9,25	D 90 x 16 x 7 x 5,5	39,64	39,72		48,37				
M 10x1,00	9,00	D 90 x 16 x 7 x 5,5	22,64	26,08	33,20	31,63				
M 10x1,25	8,80	D 100 x 22 x 7 x 5,5	25,92	31,18	36,19	34,47				
<b>M 10x1,50</b>	<b>8,50</b>	R 100 x 24 x 10 x 8,0 D 100 x 24 x 7 x 5,5	16,67	18,64	24,85	21,48	16,82*	18,29	22,99	21,48
M 11x1,00	10,00	D 90 x 20 x 8 x 6,2	40,58	41,91	105,96	96,42				
M 11x1,25	9,75	D 100 x 22 x 8 x 6,2	38,83	43,14	105,96	86,07				
<b>M 11x1,50</b>	<b>9,50</b>	D 100 x 24 x 8 x 6,2	31,48	36,19	77,26	70,27				
M 12x0,75	11,25	D 100 x 22 x 9 x 7,0	59,46							
M 12x1,00	11,00	D 100 x 22 x 9 x 7,0	30,79	35,24	40,96	40,52				
M 12x1,25	10,75	D 100 x 22 x 9 x 7,0	31,17	34,62	39,22	38,79				
M 12x1,50	10,50	D 100 x 22 x 9 x 7,0	27,86*	30,88	37,71	37,31				
<b>M 12x1,75</b>	<b>10,20</b>	D 110 x 28 x 9 x 7,0	20,08*	23,28	31,78	27,39				
M 13x0,75	12,25	D 100 x 22 x 11 x 9,0	103,78							
M 13x1,00	12,00	D 100 x 22 x 11 x 9,0	54,96	62,23						
M 13x1,25	11,75	D 100 x 22 x 11 x 9,0	54,96	62,23						
M 13x1,50	11,50	D 100 x 22 x 11 x 9,0	54,96	62,23						
<b>M 13x1,75</b>	<b>11,25</b>	D 100 x 28 x 11 x 9,0	54,57	62,23						
M 14x0,75	13,25	D 100 x 22 x 11 x 9,0	103,78							
M 14x1,00	13,00	D 100 x 22 x 11 x 9,0	49,56	54,52	63,15	62,62				
M 14x1,25	12,80	D 100 x 22 x 11 x 9,0	42,18	46,04	57,92	55,18				
M 14x1,50	12,50	D 100 x 22 x 11 x 9,0	33,18*	36,56	45,68	43,51				
<b>M 14x2,00</b>	<b>12,00</b>	D 110 x 30 x 11 x 9,0	32,96*	36,62	42,44	42,44				
M 15x1,00	14,00	D 100 x 22 x 12 x 9,0	63,03	66,73		84,97				
M 15x1,25	13,75	D 100 x 22 x 12 x 9,0	67,51	73,11						
M 15x1,50	13,50	D 100 x 22 x 12 x 9,0	53,96	61,54	157,22	127,53				
<b>M 15x2,00</b>	<b>13,00</b>	D 110 x 30 x 12 x 9,0	66,05	72,69						
M 16x1,00	15,00	D 100 x 22 x 12 x 9,0	59,41	63,03	88,42	85,85				
M 16x1,25	14,75	D 100 x 22 x 12 x 9,0	63,57	69,88	98,33	95,22				
M 16x1,50	14,50	D 100 x 22 x 12 x 9,0	39,23*	45,71	56,92	54,23				
<b>M 16x2,00</b>	<b>14,00</b>	D 110 x 32 x 12 x 9,0	38,79*	42,84	51,27	51,27				
M 17x1,00	16,00	D 100 x 22 x 12 x 9,0	118,20							
M 17x1,25	15,75	D 100 x 22 x 12 x 9,0	118,20							
M 17x1,50	15,50	D 100 x 22 x 12 x 9,0	118,20							
M 18x1,00	17,00	D 110 x 25 x 14 x 11,0	66,53	73,12		105,05				
M 18x1,25	16,75	D 110 x 25 x 14 x 11,0	82,46							
M 18x1,50	16,50	D 110 x 25 x 14 x 11,0	51,94*	57,16	69,95	68,06				
M 18x2,00	16,00	D 125 x 30 x 14 x 11,0	73,30	81,23	138,42	123,54				

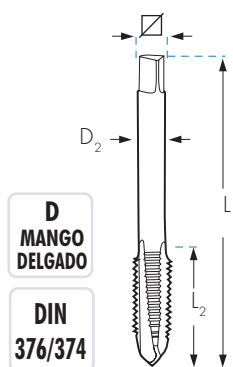
\* Consulte el precio de machos y terrajas a izquierdas disponibles en Pag.217

**MACHOS PARA ROSCAR A MÁQUINA HSSCo**
**M**  
**MF**

**HSSCo**  
**5%**
**TOL**  
**6H**
**D**  
**MANGO**  
**DELGADO**
**DIN**  
**376/374**
**Vc**  
**12**  
m/min

**D**  
**MANGO**  
**DELGADO**
**DIN**  
**376/374**

			L <sub>1</sub> x L <sub>2</sub> x D <sub>2</sub> x ∅ <small>mm</small>	M1D	M2D	M3D	M4D
				FORMA <b>C</b> €	FORMA <b>B</b> €	 15° €	 35° €
M 18x2,50	15,50	D	125 x 34 x 14 x 11,0	55,81*	61,02	69,03	66,48
M 19x1,00	18,00	D	110 x 22 x 14 x 11,0	155,30			
M 19x1,25	17,75	D	110 x 25 x 14 x 11,0	159,71			
M 19x1,50	17,50	D	110 x 25 x 14 x 11,0	152,44			
M 20x1,00	19,00	D	125 x 25 x 16 x 12,0	87,83	97,53		112,20
M 20x1,25	18,75	D	125 x 25 x 16 x 12,0	155,30			
M 20x1,50	18,50	D	125 x 25 x 16 x 12,0	58,83*	64,65	78,62	77,75
M 20x2,00	18,00	D	140 x 32 x 16 x 12,0	77,10	84,77		100,09
M 20x2,50	17,50	D	140 x 34 x 16 x 12,0	59,41*	65,88	73,67	73,68
M 21x1,00	20,00	D	125 x 25 x 16 x 12,0	225,49			
M 21x1,25	19,75	D	125 x 25 x 16 x 12,0	225,49			
M 21x1,50	19,50	D	125 x 25 x 16 x 12,0	215,34			
M 22x1,00	21,00	D	125 x 25 x 18 x 14,5	98,46	104,50		144,59
M 22x1,25	20,75	D	125 x 25 x 18 x 14,5	155,30			
M 22x1,50	20,50	D	125 x 25 x 18 x 14,5	70,81	77,89	86,24	81,14
M 22x2,00	20,00	D	140 x 32 x 18 x 14,5	98,46	108,29		144,59
M 22x2,50	19,50	D	140 x 34 x 18 x 14,5	71,89*	79,07	87,39	86,48
M 23x1,00	22,00	D	125 x 25 x 18 x 14,5	219,22			
M 23x1,50	21,50	D	125 x 25 x 18 x 14,5	219,22			
M 24x1,00	23,00	D	140 x 25 x 18 x 14,5	107,29	130,15		152,77
M 24x1,25	22,75	D	140 x 25 x 18 x 14,5	225,49			
M 24x1,50	22,50	D	140 x 28 x 18 x 14,5	87,09	95,75	115,27	109,80
M 24x2,00	22,00	D	140 x 28 x 18 x 14,5	111,11*	121,06		130,63
M 24x3,00	21,00	D	160 x 38 x 18 x 14,5	86,06*	94,19	105,32	105,11
M 25x1,00	24,00	D	140 x 28 x 18 x 14,5	207,99			
M 25x1,25	23,75	D	140 x 28 x 18 x 14,5	328,66			
M 25x1,50	23,50	D	140 x 28 x 18 x 14,5	135,50	143,41		
M 25x2,00	23,00	D	140 x 28 x 18 x 14,5	291,68	320,86		
M 26x1,00	25,00	D	140 x 28 x 18 x 14,5	161,48			
M 26x1,50	24,50	D	140 x 28 x 18 x 14,5	117,44	123,10	215,94	189,89
M 26x2,00	24,00	D	140 x 28 x 18 x 14,5	227,46	250,21		274,82
M 27x1,00	26,00	D	140 x 28 x 20 x 16,0	144,63	186,74		
M 27x1,50	25,50	D	140 x 28 x 20 x 16,0	128,23	135,84	313,83	282,97
M 27x2,00	25,00	D	140 x 28 x 20 x 16,0	158,61*	167,83		

\* Consulte el precio de machos y terrajas a izquierdas disponibles en Pag.217

MACHOS PARA ROSCAR A MÁQUINA HSSCo

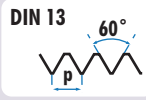
M  
MF







HSSCo  
5%

TOL  
6H

D  
MANGO  
DELGADO  
DIN  
376/374



Machos y Terrajas  
Rosa

		L <sub>1</sub> x L <sub>2</sub> x D <sub>2</sub> x 	M1D	M2D	M3D	M4D
			FORMA C	FORMA B	 15°	 35°
		mm	€	€	€	€
<b>M 27x3,00</b>	<b>24,00</b>	D 160 x 36 x 20 x 16	107,43*	117,81	129,58	129,33
M 28x1,00	27,00	D 140 x 28 x 20 x 16	291,68			
M 28x1,50	26,50	D 140 x 28 x 20 x 16	128,23	140,78	163,43	147,55
M 28x2,00	26,00	D 140 x 28 x 20 x 16	156,44	176,68	192,60	189,40
M 30x1,00	29,00	D 150 x 28 x 22 x 18	164,01	189,65		221,11
M 30x1,50	28,50	D 150 x 28 x 22 x 18	133,66	147,07	177,23	168,80
M 30x2,00	28,00	D 150 x 28 x 22 x 18	165,44*	175,59		242,96
<b>M 30x3,50</b>	<b>26,50</b>	D 180 x 40 x 22 x 18	137,67*	151,36	166,08	165,73
M 32x1,00	31,00	D 150 x 28 x 22 x 18	388,93	412,98		
M 32x1,50	30,50	D 150 x 28 x 22 x 18	169,12	185,68	218,36	
M 32x2,00	30,00	D 150 x 28 x 22 x 18	207,81	318,20		
M 33x1,00	32,00	D 160 x 30 x 25 x 20	358,20			
M 33x1,50	31,50	D 160 x 30 x 25 x 20	190,54	202,09		235,21
M 33x2,00	31,00	D 160 x 30 x 25 x 20	312,29	319,21		389,52
<b>M 33x3,50</b>	<b>29,50</b>	D 180 x 40 x 25 x 20	165,44*	190,36		211,14
M 34x1,50	32,50	D 170 x 30 x 28 x 22	212,21	224,80		
M 34x2,00	32,00	D 160 x 30 x 28 x 22	446,29			
M 35x1,50	33,50	D 170 x 30 x 28 x 22	223,80	246,17		269,20
M 35x2,00	33,00	D 170 x 30 x 28 x 22	411,82	453,36		
M 36x1,50	34,50	D 170 x 30 x 28 x 22	204,35	241,59		292,44
M 36x2,00	34,00	D 170 x 30 x 28 x 22	276,01	286,90		
M 36x3,00	33,00	D 200 x 50 x 28 x 22	316,67	329,12		423,25
<b>M 36x4,00</b>	<b>32,00</b>	D 200 x 50 x 28 x 22	217,13*	232,62	270,20	258,53
M 38x1,50	36,50	D 170 x 30 x 28 x 22	217,85	245,46		
M 38x2,00	36,00	D 170 x 32 x 28 x 22	463,04	509,37		
M 39x1,50	37,50	D 170 x 32 x 32 x 24	342,33			
M 39x2,00	37,00	D 170 x 32 x 32 x 24	342,33			
M 39x3,00	36,00	D 200 x 47 x 32 x 24	447,05			
<b>M 39x4,00</b>	<b>35,00</b>	D 200 x 50 x 32 x 24	260,50	270,79		333,90
M 40x1,50	38,50	D 170 x 30 x 32 x 24	284,85	313,53		
M 40x2,00	38,00	D 170 x 30 x 32 x 24	343,23			
M 40x3,00	37,00	D 200 x 47 x 32 x 24	336,52	401,49		
M 42x1,50	40,50	D 170 x 30 x 32 x 24	310,81	303,76		
M 42x2,00	40,00	D 170 x 30 x 32 x 24	392,65			
M 42x3,00	39,00	D 200 x 45 x 32 x 24	392,65	470,20		
<b>M 42x4,50</b>	<b>37,50</b>	D 200 x 56 x 32 x 24	334,98	348,10		372,23
M 45x1,50	43,50	D 180 x 32 x 36 x 29	371,22	408,30		
M 45x2,00	43,00	D 180 x 32 x 36 x 29	454,65			
M 45x3,00	42,00	D 200 x 47 x 36 x 29	454,65			
<b>M 45x4,50</b>	<b>40,50</b>	D 220 x 58 x 36 x 29	365,91	402,48		
M 48x1,50	46,50	D 190 x 32 x 36 x 29	365,91			
M 48x2,00	46,00	D 190 x 32 x 36 x 29	591,25			
M 48x3,00	45,00	D 220 x 52 x 36 x 29	550,95			
<b>M 48x5,00</b>	<b>43,00</b>	D 250 x 65 x 36 x 29	449,97	494,94		
M 50x1,50	48,50	D 190 x 32 x 36 x 29	443,49			
M 52x1,50	50,50	D 190 x 32 x 40 x 32	433,24			
M 52x2,00	50,00	D 190 x 32 x 40 x 32	685,61			
M 52x3,00	49,00	D 225 x 50 x 40 x 32	704,62			
<b>M 52x5,00</b>	<b>47,00</b>	D 250 x 65 x 40 x 32	460,83	570,19		

\* Consulte el precio de machos y terrajas a izquierdas disponibles en Pag.217

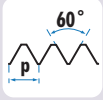
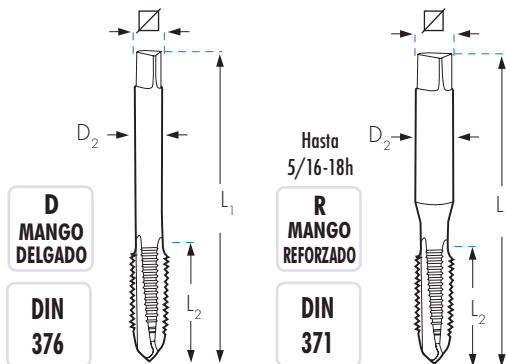
**MACHOS PARA ROSCAR A MÁQUINA HSSCo**
**UNC**

**HSSCo**  
**5%**
**TOL**  
**2B**
**Vc**  
**12 m/min**

	D1 mm		L1 x L2 x D2 x $\nabla$ mm	M1R	M2R	M4R
				FORMA C	FORMA B	35°
				€	€	€
UNC nº 4-40h	2,84	2,25	R 56 x 11 x 3,5 x 2,7	25,64	30,49	34,79
UNC nº 5-40h	3,17	2,60	R 56 x 11 x 3,5 x 2,7	26,57	31,88	34,79
UNC nº 6-32h	3,50	2,75	R 56 x 12 x 4,0 x 3,0	25,29	30,39	34,64
UNC nº 8-32h	4,17	3,50	R 63 x 13 x 4,5 x 3,4	25,29	30,39	33,13
UNC nº 10-24h	4,83	3,90	R 70 x 15 x 6,0 x 4,9	26,57	31,88	36,39
UNC nº 12-24h	5,49	4,50	R 80 x 16 x 6,0 x 4,9	27,88	31,88	33,40
UNC 1/4-20h	6,35	5,10	R 80 x 17 x 7,0 x 5,5	24,84	27,08	31,25
UNC 5/16-18h	7,94	6,60	R 90 x 20 x 8,0 x 6,2	28,11	30,99	35,29

MANGO DELGADO			M1D	M2D	M4D	
UNC 3/8-16h	9,52	8,00	D 100 x 22 x 7,0 x 5,5	32,05	33,61	37,77
UNC 7/16-14h	11,11	9,40	D 100 x 22 x 8,0 x 6,2	44,11	44,26	55,35
UNC 1/2-13h	12,70	10,75	D 110 x 24 x 9,0 x 7,0	47,87	53,04	60,54
UNC 9/16-12h	14,28	12,20	D 110 x 26 x 11,0 x 9,0	65,80	72,25	82,19
UNC 5/8-11h	15,87	13,50	D 110 x 27 x 12,0 x 9,0	63,93	70,36	79,93
UNC 3/4-10h	19,05	16,50	D 125 x 30 x 14,0 x 11,0	84,64	93,05	105,87
UNC 7/8-9h	22,22	19,50	D 140 x 32 x 18,0 x 14,5	111,37	122,36	165,66
UNC 1"-8h	25,40	22,25	D 160 x 36 x 18,0 x 14,5	147,16	160,76	207,81
UNC 1.1/8-7h	28,57	25,00	D 180 x 40 x 22,0 x 18,0	192,22		232,19
UNC 1.1/4-7h	31,75	28,00	D 180 x 40 x 22,0 x 18,0	225,30		297,04
UNC 1.3/8-6h	34,92	30,75	D 200 x 50 x 28,0 x 22,0	336,06		
UNC 1.1/2-6h	38,10	34,00	D 200 x 50 x 32,0 x 24,0	381,64		

MACHOS PARA ROSCAR A MÁQUINA HSSCo

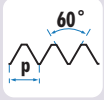
UNF



HSSCo  
5%

TOL  
2B

Vc  
12 m/min

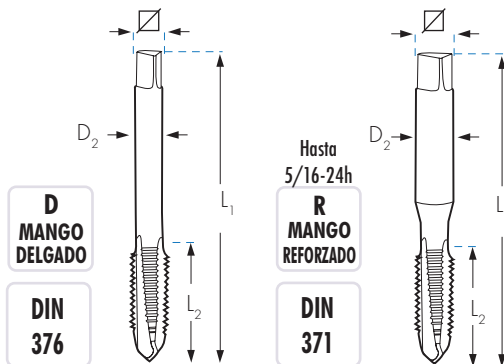

UNF nº	D1 mm	D2 mm	L1 x L2 x D2 x mm	M1R	M2R	M4R
				FORMA C	FORMA B	35°
				€	€	€
UNF nº 4-48h	2,84	2,35	R 56 x 11 x 3,5 x 2,7	26,84	29,22	36,68
UNF nº 5-44h	3,17	2,70	R 56 x 11 x 3,5 x 2,7	26,84	29,22	36,68
UNF nº 6-40h	3,50	2,95	R 56 x 12 x 4,0 x 3,0	25,67	30,74	36,40
UNF nº 8-36h	4,17	3,50	R 63 x 13 x 4,5 x 3,4	25,67	30,74	36,40
UNF nº 10-32h	4,83	4,10	R 70 x 15 x 6,0 x 4,9	25,67	30,74	36,40
UNF nº 12-28h	5,49	4,60	R 80 x 16 x 6,0 x 4,9	26,84	32,16	36,68
UNF 1/4-28h	6,35	5,50	R 80 x 17 x 7,0 x 5,5	21,68	23,22	27,09
UNF 5/16-24h	7,94	6,90	R 90 x 20 x 8,0 x 6,2	24,24	26,72	31,24

UNF	D1 mm	D2 mm	D	L1 x L2 x D2 x mm	M1D	M2D	M4D
					€	€	€
UNF 3/8-24h	9,52	8,50	D	90 x 16 x 7,0 x 5,5	26,54	30,70	39,08
UNF 7/16-20h	11,11	9,90	D	100 x 22 x 8,0 x 6,2	32,74	37,95	50,10
UNF 1/2-20h	12,70	11,50	D	100 x 22 x 9,0 x 7,0	34,86	40,35	53,30
UNF 9/16-18h	14,29	12,90	D	100 x 22 x 11,0 x 9,0	42,83	49,60	66,00
UNF 5/8-18h	15,87	14,50	D	100 x 22 x 12,0 x 9,0	48,22	55,79	73,74
UNF 3/4-16h	19,05	17,50	D	110 x 25 x 14,0 x 11,0	61,70	71,45	94,32
UNF 7/8-14h	22,22	20,40	D	125 x 25 x 18,0 x 14,5	77,59	97,06	144,28
UNF 1"-12h	25,40	23,25	D	140 x 28 x 18,0 x 14,5	116,79	127,17	169,81
UNS 1"-14h	25,40	23,60	D	140 x 28 x 18,0 x 14,5	117,31	130,82	169,82
UNF 1.1/8-12h	28,57	26,50	D	150 x 28 x 22,0 x 18,0	177,95		
UNF 1.1/4-12h	31,75	29,50	D	150 x 28 x 22,0 x 18,0	224,88		
UNF 1.1/2-12h	38,10	36,00	D	170 x 30 x 32,0 x 24,0	377,42		

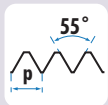
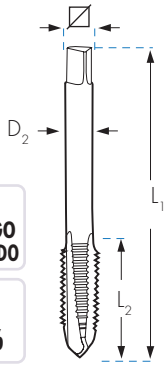
**MACHOS PARA ROSCAR A MÁQUINA HSSCo**
**BSP  
(GAS)**

**HSSCo  
5%**
**TOL  
ISO 228**
**INOX**
**Vc  
12 m/min**
**Vc  
6 m/min**

**D  
MANGO  
DELGADO**
**DIN  
5156**

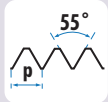

Forma	D1 mm	D	L1 x L2 x D2 x $\nabla$ mm	M1D	M2D	M3D	M4D	M2DX	M4DX
				FORMA C €	FORMA B €	FORMA B €	FORMA B €	FORMA B €	FORMA B €
G 1/8-28h.	9,728	8,80	D 90 x 16 x 7 x 5,5	33,94*	38,77	39,72	41,16	59,93	59,31
G 1/4-19h.	13,157	11,80	D 100 x 22 x 11 x 9,0	47,07*	51,82	57,04	59,11	80,74	86,42
G 3/8-19h.	16,662	15,25	D 100 x 22 x 12 x 9,0	56,36*	62,01	68,13	70,59	95,79	101,56
G 1/2-14h.	20,955	19,00	D 125 x 25 x 16 x 12,0	71,23*	78,38	85,93	89,02	118,60	128,19
G 5/8-14h.	22,911	21,00	D 125 x 25 x 18 x 14,5	88,76*	93,09	106,99	106,00		
G 3/4-14h.	26,441	24,50	D 140 x 28 x 20 x 16,0	111,49	122,71	134,50	139,36	179,20	197,70
G 7/8-14h.	30,201	28,25	D 150 x 28 x 22 x 18,0	149,87	157,66	180,90	179,21		
G 1"-11h.	33,249	30,75	D 160 x 30 x 25 x 20,0	173,06	190,32	206,53	214,00		
G 1.1/8-11h.	37,897	35,50	D 170 x 30 x 28 x 22,0	276,34	301,43		331,06		
G 1.1/4-11h.	41,910	39,50	D 170 x 30 x 32 x 24,0	324,25	341,16		377,68		
G 1.3/8-11h.	44,323	42,00	D 180 x 32 x 36 x 29,0	387,73			524,62		
G 1.1/2-11h.	47,803	45,25	D 190 x 32 x 36 x 29,0	517,04	720,77		682,81		
G 1.3/4-11h.	53,746	51,25	D 190 x 32 x 40 x 32,0	614,56	710,98				
G 2"-11h.	59,614	57,00	D 220 x 36 x 45 x 35,0	783,81	780,18				

\* Disponibles también con rosca izquierda con 100% de recargo sobre los precios tarifados en rosca derecha

**BSF**

**HSSCo  
5%**
**TOL  
ISO 228**
**Vc  
12 m/min**
**D  
MANGO  
DELGADO**
**DIN  
5156**

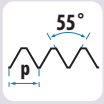
Forma	D1 mm	D	L1 x L2 x D2 x $\nabla$ mm	M1D
				FORMA C €
BSF 3/16-32h.	4,762	4,00	D 70 x 16 x 3,5 x 2,7	77,66
BSF 1/4-26h.	6,350	5,20	D 80 x 17 x 4,5 x 3,4	33,98
BSF 5/16-22h.	7,938	6,60	D 90 x 20 x 6,0 x 4,9	40,35
BSF 3/8-20h.	9,525	8,10	D 100 x 22 x 7,0 x 5,5	42,42
BSF 7/16-18h.	11,113	9,50	D 100 x 22 x 8,0 x 6,2	57,17
BSF 1/2-16h.	12,700	11,00	D 110 x 24 x 9,0 x 7,0	64,70
BSF 9/16-16h.	14,287	12,50	D 110 x 25 x 11,0 x 9,0	68,48
BSF 5/8-14h.	15,876	14,00	D 110 x 27 x 12,0 x 9,0	91,27
BSF 3/4-12h.	19,051	16,50	D 125 x 30 x 14,0 x 11,0	108,04
BSF 7/8-11h.	22,226	19,50	D 140 x 32 x 18,0 x 14,5	150,15
BSF 1"-10h.	25,400	22,50	D 160 x 36 x 18,0 x 14,5	174,54

MACHOS PARA ROSCAR A MÁQUINA HSSCo



HSSCo  
5%

TOL  
Clase 2

Vc  
12 m/min

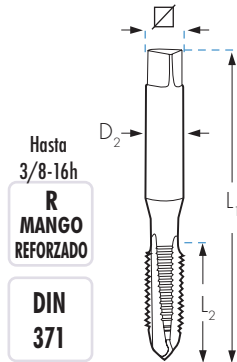
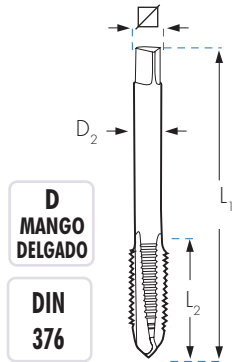

Icono	D1 mm	D	L1 x L2 x D2 x mm	M1R	M2R	M3R	M4R
				FORMA C	FORMA B	15°	35°
				€	€	€	€
W 3/32-48h.	2,38	1,80	R 50 x 9 x 2,8 x 2,1	23,59	25,18		
W 1/8-40h.	3,17	2,55	R 56 x 11 x 3,5 x 2,7	19,68*	21,75	25,68	24,71
W 5/32-32h.	3,97	3,10	R 63 x 13 x 4,5 x 3,4	19,68	21,75	25,68	24,71
W 3/16-24h.	4,76	3,60	R 70 x 15 x 6,0 x 4,9	21,84	21,75	25,68	24,71
W 7/32-24h.	5,56	4,40	R 80 x 16 x 6,0 x 4,9	29,88	31,59		
W 1/4-20h.	6,35	5,10	R 80 x 17 x 7,0 x 5,5	21,02	24,71	29,15	30,20
W 5/16-18h.	7,94	6,50	R 90 x 20 x 8,0 x 6,2	23,57	31,16	34,02	33,96
W 3/8-16h.	9,52	7,90	R 100 x 22 x 10,0 x 8,0	26,38	34,44	37,81	37,75

MANGO DELGADO			M1D	M2D	M3D	M4D	
W 7/16-14h.	11,11	9,25	D 100 x 22 x 8,0 x 6,2	36,69	37,93	47,66	48,00
W 1/2-12h.	12,70	10,50	D 110 x 24 x 9,0 x 7,0	35,18	39,55	45,66	45,99
W 9/16-12h.	14,29	12,00	D 110 x 26 x 11,0 x 9,0	50,43	52,37	65,49	65,95
W 5/8-11h.	15,87	13,40	D 110 x 27 x 12,0 x 9,0	47,75	49,48	61,93	62,36
W 3/4-10h.	19,05	16,50	D 125 x 30 x 14,0 x 11,0	66,83	69,37	82,97	83,56
W 7/8-9h.	22,22	19,25	D 140 x 32 x 18,0 x 14,5	86,56	89,76	112,31	108,15
W 1"-8h.	25,40	21,75	D 160 x 36 x 18,0 x 14,5	108,79	112,82	140,94	141,94
W 1.1/8-7h.	28,57	24,75	D 180 x 40 x 22,0 x 18,0	147,54	168,11	202,14	
W 1.1/4-7h.	31,75	27,75	D 180 x 40 x 22,0 x 18,0	214,33	244,27		
W 1.3/8-6h.	34,92	30,50	D 200 x 50 x 28,0 x 22,0	352,29	401,13		
W 1.1/2-6h.	38,10	33,50	D 200 x 50 x 32,0 x 24,0	382,38	435,79		
W 1.5/8-5h.	41,27	46,50	D 220 x 65 x 32,0 x 24,0	533,73	608,30		
W 1.3/4-5h.	44,45	39,00	D 220 x 58 x 36,0 x 29,0	571,69	656,25		
W 1.7/8-4,5h.	47,62	42,00	D 250 x 75 x 36,0 x 29,0	662,89	727,51		
W 2"-4,5h.	50,80	44,50	D 250 x 65 x 40,0 x 32,0	818,21			

\* Disponibles también con rosca izquierda con 100% de recargo sobre los precios tarifados en rosca derecha

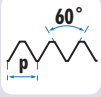
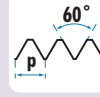
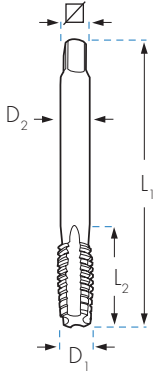
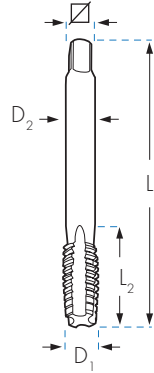
**MACHOS PARA ROSCAR A MÁQUINA HSSCo**
**UNJC**

**HSSCo**  
**5%**
**TOL**  
**3B**
**UNJF**

**HSSCo**  
**5%**
**TOL**  
**3B**
**Vc**  
**12 m/min**

**Vc**  
**12 m/min**

		D1 mm		L1 x L2 x D2 x $\nabla$ mm	MTR
					FORMA C
UNJC nº 4-40h	2,84	2,25	R	56 x 11 x 3,5 x 2,7	38,94
UNJC nº 5-40h	3,17	2,60	R	56 x 11 x 3,5 x 2,7	38,94
UNJC nº 6-32h	3,50	2,75	R	56 x 12 x 4,0 x 3,0	38,94
UNJC nº 8-32h	4,17	3,50	R	63 x 13 x 4,5 x 3,4	38,94
UNJC nº10-24h	4,83	3,90	R	70 x 15 x 6,0 x 4,9	38,94
UNJC nº12-24h	5,49	4,50	R	80 x 16 x 6,0 x 4,9	40,85
UNJC 1/4-20h	6,35	5,10	R	80 x 17 x 7,0 x 5,5	36,34
UNJC 5/16-18h	7,94	6,60	R	90 x 20 x 8,0 x 6,2	41,12
UNJC 3/8-16h	9,52	8,00	R	100 x 22 x 8,0 x 6,2	46,88

		D1 mm		L1 x L2 x D2 x $\nabla$ mm	MTR
					FORMA C
UNJF nº 4-48h	2,84	2,35	R	56 x 11 x 3,5 x 2,7	42,72
UNJF nº 5-44h	3,17	2,70	R	56 x 11 x 3,5 x 2,7	42,72
UNJF nº 6-40h	3,50	2,95	R	56 x 12 x 4,0 x 3,0	42,72
UNJF nº 8-36h	4,17	3,50	R	63 x 13 x 4,5 x 3,4	42,72
UNJF nº10-32h	4,83	4,10	R	70 x 15 x 6,0 x 4,9	42,72
UNJF nº12-28h	5,49	4,60	R	80 x 16 x 6,0 x 4,9	42,72
UNJF 1/4-28h	6,35	5,50	R	80 x 17 x 7,0 x 5,5	33,17
UNJF 5/16-24h	7,94	6,90	R	90 x 20 x 8,0 x 6,2	37,09
UNJF 3/8-24h	9,52	8,50	R	90 x 16 x 7,0 x 6,2	40,61

MANGO DELGADO PASOS NORMALES				M1D	
UNJC 7/16-14h	11,11	9,40	D	110 x 24 x 9,0 x 7,0	64,65
UNJC 1/2-13h	12,70	10,75	D	110 x 26 x 11,0 x 9,0	70,17
UNJC 9/16-12h	14,28	12,20	D	110 x 27 x 12,0 x 9,0	96,45
UNJC 5/8-11h	15,87	13,50	D	110 x 27 x 12,0 x 9,0	98,87
UNJC 3/4-10h	19,05	16,50	D	125 x 30 x 14,0 x 11,0	124,05
UNJC 7/8-9h	22,22	19,50	D	140 x 32 x 18,0 x 14,5	163,23
UNJC 1"-8h	25,40	22,25	D	160 x 36 x 18,0 x 14,5	215,66

MANGO DELGADO PASOS NORMALES				M1D	
UNJF 7/16-20h	11,11	9,90	D	100 x 22 x 8,0 x 6,2	55,77
UNJF 1/2-20h	12,70	11,50	D	100 x 22 x 9,0 x 7,0	59,39
UNJF 9/16-18h	14,29	12,90	D	100 x 22 x 11,0 x 9,0	72,97
UNJF 5/8-18h	15,87	14,50	D	100 x 22 x 12,0 x 9,0	82,15
UNJF 3/4-16h	19,05	17,50	D	110 x 25 x 14,0 x 11,0	105,10
UNJF 7/8-14h	22,22	20,40	D	125 x 25 x 18,0 x 14,5	132,16
UNJF 1"-12h	25,40	23,25	D	140 x 28 x 18,0 x 14,5	147,35



MACHOS PARA ROSCAR A MÁQUINA HSSCo

**BSPP** DIN 2999 55° HSSCo 5% DIN 374 FORMA C

**BSPT** BS21 ISO7/1 55° HSSCo 5% DIN 5156 FORMA C

ROSCA CILÍNDRICA INGLESA PARA TUBO

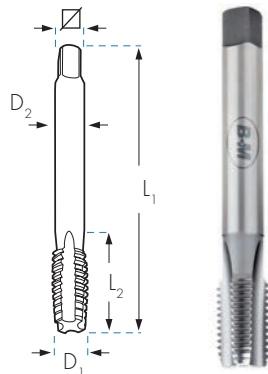

ROSCA CÓNICA INGLESA PARA TUBO

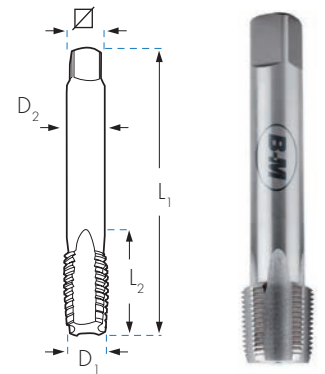

	D1 mm	L1 x L2 x D2 x ∅ mm	MTD	€
Rp 1/16-28h.	7,72	D 90 x 16 x 6 x 4,9		
Rp 1/8-28h.	9,73	D 90 x 16 x 7 x 5,5		50,65
Rp 1/4-19h.	13,16	D 100 x 22 x 11 x 9,0		69,96
Rp 3/8-19h.	16,66	D 100 x 22 x 12 x 9,0		83,77
Rp 1/2-14h.	20,95	D 125 x 25 x 16 x 12,0		105,87
Rp 3/4-14h.	26,44	D 140 x 28 x 20 x 16,0		165,78
Rp 1"-11h.	33,25	D 160 x 30 x 25 x 20,0		257,22
Rp 1.1/4-11h.	41,91	D 170 x 30 x 32 x 24,0		
Rp 1.1/2-11h.	46,80	D 190 x 32 x 36 x 29,0		
Rp 2"-11h.	59,61	D 220 x 36 x 45 x 35,0		

	D1 mm	∅	L1 x L2 x D2 x ∅ mm	MTD	€
Rc 1/16-28h.	7,72		D 90 x 14 x 6 x 4		
Rc 1/8-28h.	9,73	8,30	D 90 x 15 x 7 x 5		51,82
Rc 1/4-19h.	13,16	11,00	D 100 x 19 x 11 x 9		74,53
Rc 3/8-19h.	16,66	14,50	D 100 x 21 x 12 x 9		103,58
Rc 1/2-14h.	20,95	18,10	D 125 x 26 x 16 x 12		143,92
Rc 5/8-14h.	22,91	21,00	D 140 x 36 x 18 x 19		232,16
Rc 3/4-14h.	26,44	23,50	D 140 x 28 x 20 x 16		224,47
Rc 7/8-14h.	30,20	28,25	D 160 x 36 x 22 x 18		390,60
Rc 1"-11h.	33,25	29,60	D 160 x 33 x 25 x 20		321,71

**NPS (M)** ANSI B 1.20.1 60° HSSCo 5% DIN 374 FORMA C

**NPT** ANSI B 1.20.1 60° HSSCo 5% DIN 374 FORMA C

ROSCA CILÍNDRICA AMERICANA PARA TUBO

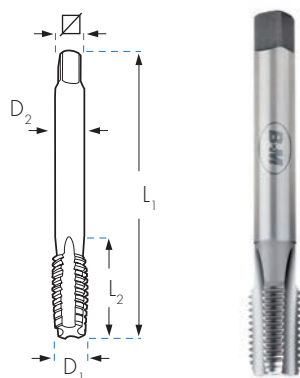

ROSCA CÓNICA AMERICANA PARA TUBO

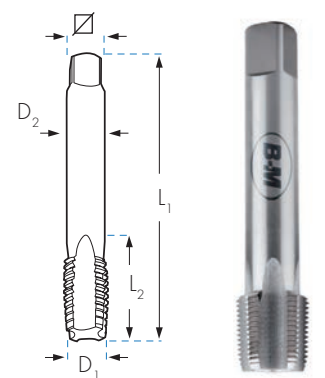

	D1 mm	∅	L1 x L2 x D2 x ∅ mm	MTD	€
NPS 1/8-27h.	10,20	8,90	D 90 x 16 x 7 x 5,5		130,46
NPS 1/4-18h.	13,60	11,70	D 100 x 22 x 11 x 9,0		186,72
NPS 3/8-18h.	17,00	15,00	D 100 x 22 x 12 x 9,0		256,05
NPS 1/2-14h.	21,20	18,60	D 125 x 25 x 16 x 12,0		351,11
NPS 3/4-14h.	26,55	24,00	D 140 x 28 x 20 x 16,0		519,05
NPS 1"-11,5 h.	33,20	30,00	D 160 x 30 x 25 x 20,0		671,23
NPS 1.1/4-11,5h.	41,60		D 170 x 30 x 32 x 24,0		
NPS 1.1/2-11,5h.	47,68		D 190 x 32 x 36 x 29,0		
NPS 2"-11,5h.	59,71		D 220 x 36 x 45 x 35,0		

	D1 mm	∅	L1 x L2 x D2 x ∅ mm	MTD	€
NPT 1/16-27h.	7,89	6,2	D 90 x 14 x 6 x 5		45,39
NPT 1/8-27h.	10,24	8,5	D 90 x 15 x 8 x 6		47,47
NPT 1/4-18h.	13,62	11,0	D 100 x 19 x 11 x 9		61,30
NPT 3/8-18h.	17,05	14,5	D 100 x 21 x 12 x 9		78,80
NPT 1/2-14h.	21,22	17,8	D 125 x 26 x 16 x 12		102,51
NPT 3/4-14h.	26,57	23,0	D 140 x 28 x 20 x 16		158,83
NPT 1"-11,5h.	33,23	29,0	D 160 x 33 x 25 x 20		206,44
NPT 1.1/4-11,5h.	41,98	37,5	D 170 x 36 x 32 x 24		281,86
NPT 1.1/2-11,5h.	48,05	44,0	D 190 x 37 x 36 x 29		443,82
NPT 2"-11,5h.	60,09	56,0	D 220 x 41 x 45 x 35		696,18

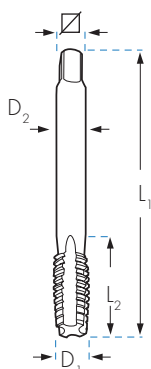
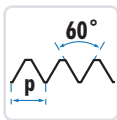
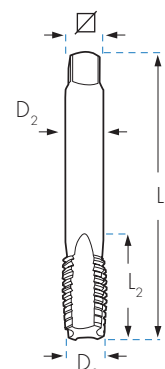
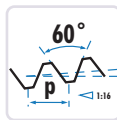
**MACHOS PARA ROSCAR A MÁQUINA HSSCo**
**NPSF**
**HSSCo**  
**5%**
**DIN**  
**374**
**FORMA**  
**C**

**ROSCA PARA TUBO**  
**AMERICANA CILÍNDRICA**
**NPTF**
**HSSCo**  
**5%**
**DIN**  
**374**
**FORMA**  
**C**

**ROSCA PARA TUBO**  
**AMERICANA CÓNICA ESTANCA**

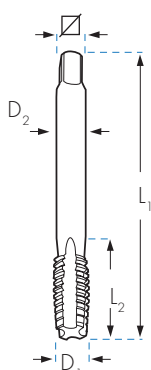
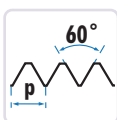
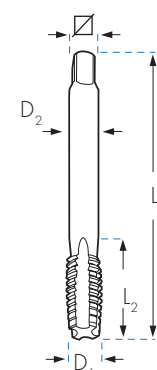
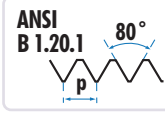
			D1 mm		$L_1 \times L_2 \times D_2 \times \square$ mm	MID €
NPSF 1/8-27h.			10,05	8,75	D 90 x 16 x 7 x 5,5	163,42
NPSF 1/4-18h.			13,33	11,30	D 100 x 22 x 11 x 9,0	225,25
NPSF 3/8-18h.			16,78	14,70	D 100 x 22 x 12 x 9,0	320,44
NPSF 1/2-14h.			20,87	18,20	D 125 x 25 x 16 x 12,0	399,60
NPSF 3/4-14h.			26,23	23,50	D 140 x 28 x 20 x 16,0	654,00
NPSF 1"-11,5h.			32,81	29,50	D 160 x 30 x 25 x 20,0	

			D1 mm		$L_1 \times L_2 \times D_2 \times \square$ mm	MID €
NPTF 1/16-27h.			7,87	6,20	D 90 x 14 x 12,0 x 6	
NPTF 1/8-27h.			10,22	8,50	D 90 x 15 x 12,0 x 7	110,41
NPTF 1/4-18h.			13,58	11,00	D 100 x 21 x 17,5 x 11	154,90
NPTF 3/8-18h.			17,02	14,50	D 110 x 21 x 17,6 x 12	198,99
NPTF 1/2-14h.			21,21	17,80	D 140 x 27 x 22,8 x 16	259,05
NPTF 3/4-14h.			26,56	23,00	D 140 x 27 x 23,0 x 20	401,32

**MF**
**HSSCo**  
**5%**
**TOL**  
**6H**
**FORMA**  
**C**
**DIN**  
**374**

**ROSCA MÉTRICA FINA PARA**  
**TUBO DE CONDUCCIÓN**  
**ELÉCTRICA EN 60423**
**PG**
**HSSCo**  
**5%**
**DIN**  
**40430**
**FORMA**  
**C**

**ROSCA PARA TUBO**  
**DE CONDUCCIÓN**  
**ELÉCTRICA**

			D1 mm		$L_1 \times L_2 \times D_2 \times \square$ mm	MID €
MF 12 x 1,50			12	10,5	D 100 x 22 x 9 x 7,0	27,86
MF 16 x 1,50			16	14,5	D 100 x 22 x 12 x 9,0	39,23
MF 20 x 1,50			20	18,5	D 125 x 25 x 16 x 12,0	58,83
MF 25 x 1,50			25	23,5	D 140 x 28 x 18 x 14,5	135,50
MF 32 x 1,50			32	30,5	D 150 x 28 x 22 x 18,0	169,12
MF 40 x 1,50			40	38,5	D 170 x 30 x 32 x 24,0	284,85
MF 50 x 1,50			50	48,5	D 190 x 32 x 36 x 29,0	443,49
MF 63 x 1,50			63	61,5	D 275 x 36 x 50 x 39,0	

			D1 mm		$L_1 \times L_2 \times D_2 \times \square$ mm	MID €
PG 7 - 20h.			12,5	11,50	D 100 x 22 x 9 x 7,0	48,45
PG 9 - 18h.			15,2	14,00	D 100 x 22 x 12 x 9,0	67,10
PG 11 - 18h.			18,6	17,25	D 110 x 25 x 14 x 11,0	87,30
PG 13,5 - 18h.			20,4	19,00	D 125 x 25 x 16 x 12,0	98,04
PG 16 - 18h.			22,5	21,25	D 125 x 25 x 18 x 14,5	115,38
PG 21 - 16h.			28,3	27,00	D 150 x 28 x 22 x 18,0	183,17
PG 29 - 16h.			37,0	35,50	D 170 x 30 x 28 x 22,0	309,65
PG 36 - 16h.			47,0	45,50	D 190 x 32 x 36 x 29,0	502,89
PG 42 - 16h.			54,0	52,50	D 190 x 32 x 40 x 32,0	798,67
PG 48 - 16h.			59,3	58,00	D 220 x 36 x 45 x 35,0	973,64

MACHOS PARA ROSCAR A MÁQUINA HSSCo

**UNx8** HSSCo 5% DIN 374 FORMA C TOL 2B

ANSI/ASME B 1.1 60°

**UNEF** HSSCo 5% DIN 374 TOL 2B

ANSI/ASME B 1.1 60°

		D <sub>2</sub> mm	L <sub>1</sub> x L <sub>2</sub> x mm	M1D FORMA C €
UN 1" 1/8-8h.	25,40	22	180 x 45 x 18	240,85
UN 1" 1/4-8h.	28,50	22	180 x 48 x 18	310,74
UN 1" 3/8-8h.	31,75	28	200 x 56 x 22	352,49
UN 1" 1/2-8h.	35,00	32	200 x 58 x 22	448,49
UN 1" 5/8-8h.	38,10	32	200 x 65 x 24	524,62
UN 1" 3/4-8h.	41,25	36	200 x 50 x 29	639,07
UN 1" 7/8-8h.	44,45	36	225 x 53 x 29	737,18
UN 2"-8h.	47,63	40	225 x 50 x 32	753,23

		D <sub>2</sub> mm	L <sub>1</sub> x L <sub>2</sub> x mm	M2D FORMA B €	M4D 35° €
UNEF 1/4-32h.	5,55	7,0	R 82 x 16 x 5,4	99,66	112,00
UNEF 5/16-32h.	7,15	8,4	R 85 x 21 x 6,1	109,81	123,38
UNEF 3/8-32h.	8,70	7,0	D 95 x 22 x 5,4	109,87	123,45
UNEF 7/16-28h.	10,20	8,0	D 100 x 22 x 6,2	145,83	163,85
UNEF 1/2-28h.	11,80	9,0	D 100 x 22 x 7,0	153,60	172,59
UNEF 9/16-24h.	13,20	12,0	D 100 x 24 x 9,0	192,44	216,23
UNEF 5/8-24h.	14,80	12,0	D 100 x 24 x 9,0	218,99	246,06
UNEF 3/4-20h.	17,80	14,0	D 110 x 27 x 11,0	284,81	320,04
UNEF 7/8-20h.	20,95	18,0	D 125 x 26 x 14,5	306,15	328,02
UNEF 1"-20h.	24,20	18,0	D 140 x 28 x 14,5	468,51	526,42

MACHOS PARA ROSCAR A MÁQUINA HSSCo ROSCA A IZQUIERDA

**M MF** HSSCo 5% FORMA C TOL 6H

DIN 13 60°

Vc 12 m/min

IZQUIERDA

**D MANGO DELGADO** DIN 376/374

**R MANGO REFORZADO** DIN 371

			L <sub>1</sub> x L <sub>2</sub> x D <sub>2</sub> x mm	M1RI FORMA C €
M 3x0,50	2,50	R	56 x 11 x 3,5 x 2,7	22,66
M 4x0,70	3,30	R	63 x 13 x 4,5 x 3,4	25,79
M 5x0,80	4,20	R	70 x 16 x 6,0 x 4,9	23,09
M 6x1,00	5,00	R	80 x 17 x 6,0 x 4,9	26,27
M 7x1,00	6,00	R	80 x 17 x 7,0 x 5,5	34,07
M 8x1,25	6,80	R	90 x 20 x 8,0 x 6,2	29,68
M 10x1,50	8,50	R	100 x 22 x 10,0 x 8,0	33,64

			MANGO DELGADO	M1DI
M 12x1,50	10,50	D	100 x 22 x 9,0 x 7,0	55,72
M 12x1,75	10,20	D	110 x 24 x 9,0 x 7,0	40,15
M 14x1,50	12,50	D	100 x 22 x 11,0 x 9,0	66,36
M 14x2,00	12,00	D	110 x 26 x 11,0 x 9,0	65,92
M 16x1,50	14,50	D	100 x 22 x 12,0 x 9,0	78,46
M 16x2,00	14,00	D	110 x 27 x 12,0 x 9,0	77,59
M 18x1,50	16,50	D	110 x 25 x 14,0 x 11,0	103,88
M 18x2,50	15,50	D	125 x 30 x 14,0 x 11,0	111,62
M 20x1,50	18,50	D	125 x 25 x 16,0 x 12,0	117,65
M 20x2,50	17,50	D	140 x 32 x 16,0 x 12,0	118,81
M 22x2,50	19,50	D	140 x 32 x 18,0 x 14,5	143,77
M 24x2,00	22,00	D	140 x 28 x 18,0 x 14,5	222,23
M 24x3,00	21,00	D	160 x 34 x 18,0 x 14,5	172,11
M 27x3,00	24,00	D	160 x 36 x 20,0 x 16,0	214,86
M 30x2,00	28,00	D	150 x 28 x 22,0 x 18,0	330,88
M 30x3,50	26,50	D	180 x 40 x 22,0 x 18,0	275,33
M 33x3,50	29,50	D	180 x 40 x 25,0 x 20,0	330,88
M 36x4,00	32,00	D	200 x 50 x 28,0 x 22,0	434,27

Consulte otras medidas disponibles bajo demanda

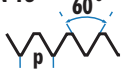
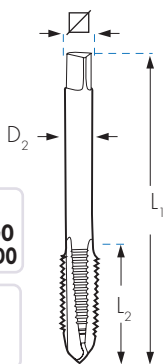
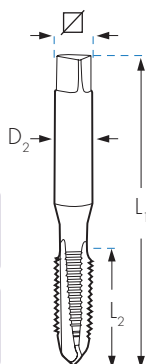
**MACHOS MÁQUINA MÉTRICA NORMA ISO 529**
**M  
MF**
**DIN 13**

**HSSCo  
5%**
**ISO  
529**
**TOL  
6H**
**D  
MANGO  
DELGADO**  
  
**ISO  
529**

**R  
MANGO  
REFORZADO**  
  
**ISO  
529**

			L1 x L2 x D2 x $\square$ mm	M1RISO	M2RISO	M4RISO	M5RISO
				FORMA C	FORMA B	35°	DIENTE ALTERNO AI
				€	€	€	€
M 3x0,50	2,50	R	48 x 11 x 3,15 x 2,50	8,17	8,52	10,26	12,20
M 4x0,70	3,30	R	53 x 13 x 4,00 x 3,15	8,17	8,52	10,26	12,20
M 5x0,80	4,20	R	58 x 16 x 5,00 x 4,00	8,17	8,52	10,26	12,20
M 6x1,00	5,00	R	66 x 19 x 6,30 x 5,00	8,17	8,52	10,48	12,20
M 7x1,00	6,00	R	66 x 19 x 7,10 x 5,60		12,12	13,91	
M 8x1,00	7,00	R	69 x 19 x 8,00 x 6,30		16,72	17,16	
M 8x1,25	6,75	R	72 x 22 x 8,00 x 6,30	10,92	11,37	11,76	13,33
M 9x1,25	7,75	R	76 x 20 x 10,00 x 8,00		18,09	20,66	
M 10x1,00	9,00	R	76 x 20 x 10,00 x 8,00		19,18	20,95	
M 10x1,25	8,80	R	76 x 20 x 10,00 x 8,00		22,93	23,67	
M 10x1,50	8,50	R	80 x 24 x 10,00 x 8,00	13,89	14,47	15,16	16,82
<b>MANGO DELGADO</b>				<b>M1DISO</b>	<b>M2DISO</b>	<b>M4DISO</b>	<b>M5DISO</b>
M 12x1,00	11,00	D	84 x 24 x 9,00 x 7,10		26,42	27,07	
M 12x1,25	10,75	D	84 x 24 x 9,00 x 7,10		25,95	26,87	
M 12x1,50	10,50	D	89 x 29 x 9,00 x 7,10		23,15	24,93	
M 12x1,75	10,20	D	89 x 29 x 9,00 x 7,10	17,85	18,59	19,69	25,16
M 14x1,00	13,00	D	90 x 25 x 11,20 x 9,00		33,09	41,16	
M 14x1,25	12,80	D	90 x 25 x 11,20 x 9,00		27,94	34,99	
M 14x1,50	12,50	D	95 x 30 x 12,50 x 9,00		24,55	27,59	
M 14x2,00	12,00	D	95 x 30 x 11,20 x 9,00	21,34	22,23	26,91	
M 16x1,00	15,00	D	95 x 25 x 12,50 x 10,00		42,10	54,18	
M 16x1,25	14,75	D	102 x 32 x 12,50 x 10,00		46,68	60,08	
M 16x1,50	14,50	D	102 x 32 x 14,00 x 10,00		29,47	33,02	
M 16x2,00	14,00	D	102 x 32 x 12,50 x 10,00	26,50	27,60	31,22	
M 18x1,50	16,50	D	104 x 29 x 14,00 x 11,20		38,93	53,20	
M 18x2,50	15,50	D	112 x 37 x 14,00 x 11,20	39,90	41,56	51,96	
M 20x1,50	18,50	D	104 x 29 x 14,00 x 11,20		50,10	61,28	
M 20x2,50	17,50	D	112 x 37 x 14,00 x 11,20	44,60	46,46	58,07	
M 22x2,50	19,50	D	118 x 38 x 16,00 x 12,50	51,57	53,72	67,15	
M 24x3,00	21,00	D	130 x 45 x 18,00 x 14,00	58,26	60,69	75,85	
M 27x3,00	24,00	D	135 x 45 x 20,00 x 16,00	71,74	74,73	93,42	
M 30x3,50	26,50	D	138 x 48 x 20,00 x 16,00	106,59	111,04	138,79	

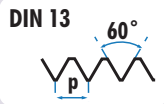
MACHOS MÁQUINA CORTOS DIN 352

M  
MF



HSS

HSSCo  
5%

DIN  
352

TOL  
6H

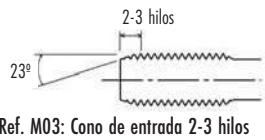

Ref. M03: Cono de entrada 2-3 hilos

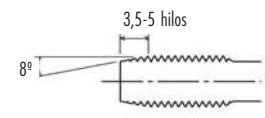

Ref. M02AT: Cono de entrada 3,5-5 hilos

D  
MANGO  
DELGADO

DIN  
352

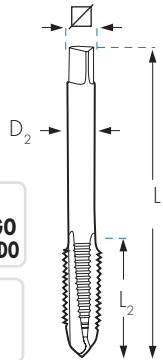

Icono	D	L1 x L2 x D2 x $\square$ mm	M03	M02AT	M03X	M02DIN	M04DIN
			HSS €	ALTURA TERMINADA HSS €	INOX HSSCo €	FORMA B HSS €	35° HSS €
M 3x0,50	2,50	D 40 x 11 x 3,50 x 2,70	7,36	9,93	13,14	9,37	11,29
M 4x0,70	3,30	D 45 x 13 x 4,50 x 3,40	7,35	9,92	13,14	9,37	11,29
M 5x0,80	4,20	D 50 x 16 x 6,00 x 4,90	7,86	10,62	13,68	9,37	11,29
M 6x1,00	5,00	D 50 x 19 x 6,00 x 4,90	7,86	10,62	13,63	9,37	11,53
M 7x1,00	6,00	D 50 x 19 x 6,00 x 4,90	9,58				
M 8x1,00	7,00	D 56 x 18 x 6,00 x 4,90	13,25				
M 8x1,25	6,75	D 56 x 22 x 6,00 x 4,90	9,57	12,92	15,87	12,51	13,98
M 9x1,25	7,75	D 63 x 18 x 7,00 x 5,50	15,67				
M 10x1,00	9,00	D 63 x 18 x 7,00 x 5,50	14,19				
M 10x1,25	8,80	D 70 x 24 x 7,00 x 5,50	14,38				
M 10x1,50	8,50	D 70 x 24 x 7,00 x 5,50	11,80	15,92	20,41	15,91	17,62
M 12x1,00	11,00	D 70 x 20 x 9,00 x 7,00	25,16				
M 12x1,25	10,75	D 70 x 20 x 9,00 x 7,00	25,08				
M 12x1,50	10,50	D 70 x 20 x 9,00 x 7,00	21,37				
M 12x1,75	10,20	D 75 x 29 x 9,00 x 7,00	16,60	22,42	29,23	20,46	22,94
M 14x1,00	13,00	D 70 x 20 x 11,00 x 9,00	39,21				
M 14x1,25	12,80	D 70 x 20 x 11,00 x 9,00	30,63				
M 14x1,50	12,50	D 70 x 20 x 11,00 x 9,00	23,82				
M 14x2,00	12,00	D 80 x 30 x 11,00 x 9,00	18,36	24,79	32,37	24,45	29,61
M 16x1,00	15,00	D 70 x 20 x 12,00 x 9,00	52,02				
M 16x1,25	14,75	D 70 x 20 x 12,00 x 9,00	54,75				
M 16x1,50	14,50	D 70 x 20 x 12,00 x 9,00	29,64				
M 16x2,00	14,00	D 80 x 32 x 12,00 x 9,00	26,27		44,37	30,37	34,33
M 18x1,50	16,50	D 80 x 22 x 14,00 x 11,00	39,05				
M 18x2,50	15,50	D 95 x 40 x 14,00 x 11,00	34,67		60,59	45,72	57,16
M 20x1,50	18,50	D 80 x 22 x 16,00 x 12,00	48,90				
M 20x2,50	17,50	D 95 x 40 x 16,00 x 12,00	38,89		67,26	51,10	63,88
M 22x2,50	19,50	D 100 x 40 x 18,00 x 14,50	51,81			59,08	73,87
M 24x3,00	21,00	D 110 x 50 x 18,00 x 14,50	61,79			66,76	83,44
M 27x3,00	24,00	D 110 x 50 x 20,00 x 16,00	78,14			86,17	94,59
M 30x3,50	26,50	D 125 x 50 x 22,00 x 18,00	100,53			118,03	121,22

MACHOS DE MÁQUINA Y COJINETES SERIE *Plus* Y *Super Plus*

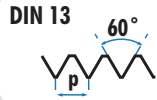

TOL  
6H

PARA TRABAJOS DE ALTA PRODUCCIÓN  
FABRICADOS EN ACERO SINTERIZADO

DIN  
22568

TOL  
6g



*Plus* *Plus TiN* *Plus LUBE* *Super Plus ALTiN*

CALIDAD	M2RP		M4RP		M2RT		M4RT		M2RHL		M4RHL		M2RSP		M4RSP		C5P	
	★★	★★	★★★	★★★	★★★★	★★★★	★★★	★★★	★★★★	★★★★	★★★	★★★	★★★★	★★★★				
MATERIAL	HSS PM		HSS PM		HSSCo 5%		HSSCo 5%		HSS PM		HSS PM		HSS V3		HSS V3		HSS	
ACABADO	BRILLANTE		BRILLANTE		TiN		TiN		HARD LUBE		HARD LUBE		ALTiN		ALTiN		BRILLANTE	
ÁNGULO DE HÉLICE	FORMA B		35°		FORMA B		35°		FORMA B		35°		FORMA B		41°			
	L <sub>1</sub> x L <sub>2</sub> x D <sub>2</sub> x ∠ mm		€	€	€	€	€	€	€	€	€	€	€	€	€	€	∅ x L <sub>3</sub> mm	€
M 3x0,50	2,50	R	56 x 11 x 3,5 x 2,7	16,75	20,70	22,55	24,92	30,20	32,69	40,58	42,47	25 x 9	30,82					
M 4x0,70	3,30	R	63 x 13 x 4,5 x 3,4	17,11	20,70	22,91	25,99	30,66	33,14	40,58	42,47	25 x 9	30,82					
M 5x0,80	4,20	R	70 x 16 x 6,0 x 4,9	17,11	19,84	22,91	25,99	30,66	33,14	42,86	44,05	25 x 9	30,82					
M 6x1,00	5,00	R	80 x 17 x 6,0 x 4,9	18,82	21,79	26,38	28,57	33,66	35,09	42,86	44,05	25 x 9	30,82					
M 8x1,00	7,00	D	90 x 20 x 6,0 x 4,9	26,86	31,87	37,82	42,09	51,06	56,83			25 x 9	42,98					
M 8x1,25	6,80	R	90 x 20 x 8,0 x 6,2	22,03	25,31	30,84	33,54	42,80	44,65	54,41	57,98	25 x 9	33,43					
M 10x1,00	9,00	D	90 x 16 x 7,0 x 5,5	29,94	37,54	44,18	50,72	59,62	70,44			30 x 10	52,53					
M 10x1,50	8,50	R	100 x 22 x 10,0 x 8,0	25,92	29,47	36,32	39,77	53,08	55,56	64,84	69,17	30 x 10	45,97					
<b>MANGO DELGADO</b>			M2DP	M4DP	M2DT	M4DT	M2DHL	M4DHL	M2DSP	M4DSP								
M 12x1,50	10,50	D	100 x 22 x 9,0 x 7,0	35,52	42,94	47,85	53,87	64,30	73,75			38 x 10	54,61					
M 12x1,75	10,20	D	110 x 24 x 9,0 x 7,0	33,41	39,68	44,78	50,49	56,03	67,25	81,58	88,50	38 x 14	48,22					
M 14x1,50	12,50	D	100 x 22 x 11,0 x 9,0	42,09	52,78	56,27	62,15	75,63	86,73			38 x 10	57,09					
M 14x2,00	12,00	D	110 x 26 x 11,0 x 9,0	41,77	48,42	55,26	60,75	76,43	84,01	83,29	112,14	38 x 14	49,15					
M 16x1,50	14,50	D	100 x 22 x 12,0 x 9,0	52,65	64,91	67,63	77,32	74,68	87,17			45 x 14	78,42					
M 16x2,00	14,00	D	110 x 27 x 12,0 x 9,0	49,12	58,52	63,09	69,74	87,26	96,44	113,69	120,94	45 x 18	66,03					
M 18x2,50	15,50	D	125 x 30 x 14,0 x 11,0	69,63	78,66	86,15	93,99	123,27	130,97	168,75	182,57	45 x 18	66,03					
M 20x2,50	17,50	D	140 x 32 x 16,0 x 12,0	75,23	83,85	98,19	105,78	129,51	147,46	179,85	190,10	45 x 18	66,03					
M 22x2,50	19,50	D	140 x 32 x 18,0 x 14,5	91,01	103,47	110,97	118,78	151,90	165,76			55 x 22	98,15					
M 24x3,00	21,00	D	160 x 34 x 18,0 x 14,5	108,21	123,87	125,04	135,87	171,16	189,59			55 x 22	98,15					

**MACHOS DE MÁQUINA PARA TRABAJOS ESPECIALES HSS-PM**

**INOX**

**M**

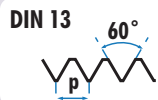

**TOL  
6H**

**Vc  
6 m/min**

**Vc  
10 m/min**

**Vc  
12 m/min**

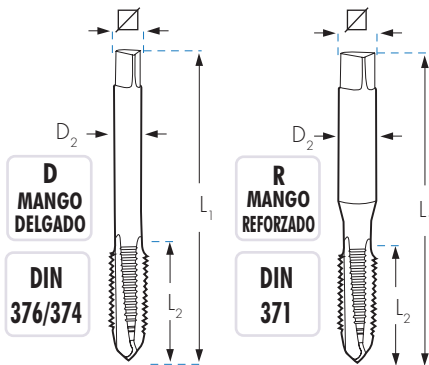

CALIDAD	M2RX		M4RX		M2RXT		M4RXT		M2RXHL		M4RXHL	
	★★	★★	★★	★★	★★★	★★★	★★★	★★★	★★★★	★★★★	★★★★	★★★★
MATERIAL	HSS PM		HSS PM		HSSCo 5%		HSSCo 5%		HSS PM		HSS PM	
ACABADO	OX		OX		TIN		TIN		HARD LUBE		HARD LUBE	
ÁNGULO DE HÉLICE	FORMA B		FORMA B 35°		FORMA B		FORMA B 35°		FORMA B		FORMA B 35°	
	L1 x L2 x D2 x ∅		€	€	€	€	€	€	€	€	€	€
M 3x0,50	2,50	R	56 x 11 x 3,5 x 2,7	20,02	23,79	23,12	26,16	30,58	35,96			
M 4x0,70	3,30	R	63 x 13 x 4,5 x 3,4	21,02	23,79	24,25	26,59	32,12	36,90			
M 5x0,80	4,20	R	70 x 16 x 6,0 x 4,9	21,02	23,97	24,25	26,99	32,12	37,46			
M 6x1,00	5,00	R	80 x 17 x 6,0 x 4,9	23,03	25,92	25,68	28,22	35,17	39,19			
M 8x1,00	7,00	D	90 x 20 x 6,0 x 4,9	37,18	40,74							
M 8x1,25	6,80	R	90 x 20 x 8,0 x 6,2	25,69	29,53	29,68	32,51	39,27	45,13			
M 10x1,00	9,00	D	90 x 16 x 7,0 x 5,5	38,32	40,91							
M 10x1,50	8,50	R	100 x 22 x 10,0 x 8,0	31,42	35,04	34,70	38,34	47,98	53,52			
<b>MANGO DELGADO</b>			<b>M2DX</b>	<b>M4DX</b>	<b>M2DXT</b>	<b>M4DXT</b>	<b>M2DXHL</b>	<b>M4DXHL</b>				
M 12x1,00	11,00	D	100 x 22 x 9,0 x 7,0	43,46	49,86							
M 12x1,50	10,50	D	100 x 22 x 9,0 x 7,0	44,11	52,16							
M 12x1,75	10,20	D	110 x 24 x 9,0 x 7,0	40,37	47,27	44,39	49,97	63,18	73,96			
M 14x2,00	12,00	D	110 x 26 x 11,0 x 9,0	57,47	65,83	57,83	62,51	83,95	92,96			
M 16x2,00	14,00	D	110 x 27 x 12,0 x 9,0	64,00	75,97	65,64	71,93	93,47	112,44			
M 18x2,50	15,50	D	125 x 30 x 14,0 x 11,0	95,84	108,10	98,95	102,68	149,99	159,97			
M 20x2,50	17,50	D	140 x 32 x 16,0 x 12,0	103,57	114,16	112,98	116,00	159,46	168,91			
M 22x2,50	19,50	D	140 x 32 x 18,0 x 14,5	124,28	131,31	140,25	151,85					
M 24x3,00	21,00	D	160 x 34 x 18,0 x 14,5	130,66	149,97	142,98	155,32					
M 27x3,00	24,00	D	160 x 36 x 20,0 x 16,0	171,15	196,45							
M 30x3,50	26,50	D	180 x 40 x 22,0 x 18,0	218,87	251,22							



- Lubricación: **CUT MAGIC XTHICK**
- Se recomienda la aplicación del Aceite de corte CUT MAGIC XTHICK para optimizar el proceso de roscado en Inoxidables, Inconel, Titanio, Dúplex, etc...

Ref. ACXT00250

MACHOS *Super Plus* PARA EL ROSCADO DE ALEACIONES REFRACTARIAS

Machos y Terrajos

Rosa

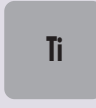
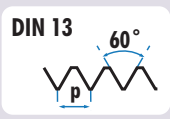

ESPECIALMENTE RECOMENDADOS  
EN APLICACIONES AERONAÚTICAS

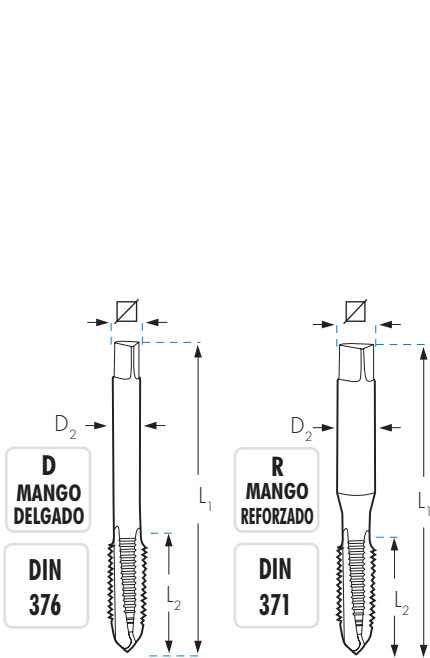

			M2RDU	M4RDU	M2RNI	M3RNI	M2RTIT	M3RTIT
CALIDAD			★★★★	★★★★	★★★★	★★★★	★★★★	★★★★
MATERIAL			HSS V3	HSS V3	HSS PM	HSS PM	HSS PM	HSS PM
ACABADO			TiCN	TiCN	BRILLANTE	BRILLANTE	OX	OX
ÁNGULO DE HÉLICE			FORMA B	41°	FORMA B	15°	FORMA B	15°
		L1 x L2 x D2 x $\square$ mm	€	€	€	€	€	€
M 3x0,50	2,50	R 56 x 11 x 3,5 x 2,7	41,15	42,15	76,45	78,12	56,76	62,65
M 4x0,70	3,30	R 63 x 13 x 4,5 x 3,4	41,15	42,41	78,12	80,24	58,53	62,65
M 5x0,80	4,20	R 70 x 16 x 6,0 x 4,9	42,53	43,36	80,88	82,79	60,01	66,73
M 6x1,00	5,00	R 80 x 17 x 6,0 x 4,9	43,70	44,63	81,51	83,82	60,01	67,66
M 8x1,25	6,80	R 90 x 20 x 8,0 x 6,2	61,04	63,64	92,12	94,57	69,34	78,12
M 10x1,50	8,50	R 100 x 22 x 10,0 x 8,0	79,11	81,17	109,45	112,80	85,88	94,14
<b>MANGO DELGADO</b>			M2DDU	M4DDU	M2DNI	M3DNI	M2DTIT	M3DTIT
M 12x1,75	10,20	D 110 x 24 x 9,0 x 7,0	106,95	115,49	140,78	155,66	107,78	116,96
M 14x2,00	12,00	D 110 x 26 x 11,0 x 9,0						
M 16x2,00	14,00	D 110 x 27 x 12,0 x 9,0	157,28	168,18				
M 18x2,50	15,50	D 125 x 30 x 14,0 x 11,0						
M 20x2,50	17,50	D 140 x 32 x 16,0 x 12,0	232,89	251,55				
M 22x2,50	19,50	D 140 x 32 x 18,0 x 14,5						
M 24x3,00	21,00	D 160 x 34 x 18,0 x 14,5	315,44	320,85				
M 27x3,00	24,00	D 160 x 36 x 20,0 x 16,0	405,25	424,79				
M 30x3,50	26,50	D 180 x 40 x 22,0 x 18,0	478,61	500,81				



**MACHOS DE MÁQUINA PARA ACEROS ESTRUCTURALES SUPER BLANDOS < DE 450 N/mm<sup>2</sup>**

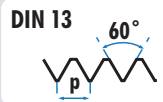

**HSSCo**  
5%

**OX**

**TOL**  
6H

**APLICACIONES**







**ST52**

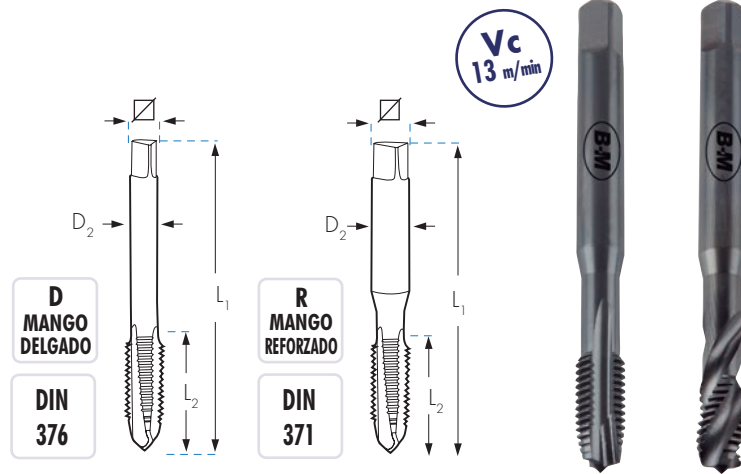

Geometría de corte específica para materiales blandos, no genera SOBREMEDIDA y se ajusta perfectamente a este tipo de materiales donde los machos convencionales, pueden provocar agrandamientos a la hora de generar la rosca.

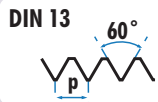
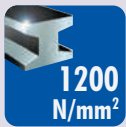
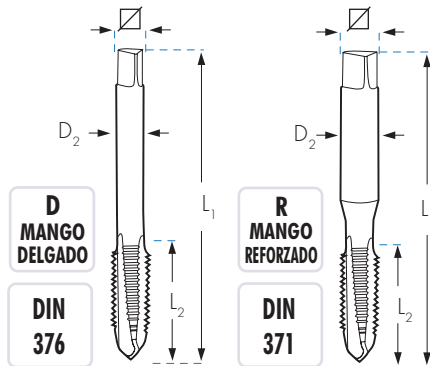

		L <sub>1</sub> x L <sub>2</sub> x D <sub>2</sub> x  mm	M2RSS	M4RSS
			FORMA B	
			€	€
M 3 x 0,50	2,50	R 56 x 11 x 3,5 x 2,7	14,26	19,05
M 4 x 0,70	3,30	R 63 x 13 x 4,5 x 3,4	14,92	19,06
M 5 x 0,80	4,20	R 70 x 16 x 6,0 x 4,9	14,94	18,28
M 6 x 1,00	5,00	R 80 x 17 x 6,0 x 4,9	16,39	20,04
M 8 x 1,25	6,80	R 90 x 20 x 8,0 x 6,2	18,39	22,67
M 10 x 1,50	8,50	R 100 x 22 x 10,0 x 8,0	22,65	26,85
<b>MANGO DELGADO</b>			M2DSS	M4DSS
M 12 x 1,75	10,20	D 110 x 24 x 9,0 x 7,0	28,56	34,58
M 14 x 2,00	12,00	D 110 x 26 x 11,0 x 9,0	42,17	49,80
M 16 x 2,00	14,00	D 110 x 27 x 12,0 x 9,0	49,32	60,16
M 18 x 2,50	15,50	D 125 x 30 x 14,0 x 11,0	70,26	77,99
M 20 x 2,50	17,50	D 140 x 32 x 16,0 x 12,0	75,84	86,46
M 22 x 2,50	19,50	D 140 x 32 x 18,0 x 14,5	91,04	101,46
M 24 x 3,00	21,00	D 160 x 34 x 18,0 x 14,5	108,44	123,32
M 27 x 3,00	24,00	D 160 x 36 x 20,0 x 16,0	135,63	151,73
M 30 x 3,50	26,50	D 180 x 40 x 22,0 x 18,0	174,27	194,45

**MACHOS DE MÁQUINA PARA TRABAJOS ESPECIALES HSS-V3**

**HSS  
V3**
**TOL  
6H**
**MATERIALES  
DUROS**

**Vc  
7 m/min**
**Vc  
9 m/min**

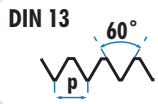
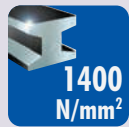
		M2RMD	M4RMD	M2RMDTX	M4RMDTX
CALIDAD		★★★	★★★	★★★★	★★★★
MATERIAL		HSS V3	HSS V3	HSS V3	HSS V3
ACABADO		OX	OX	TINALOX	TINALOX
ÁNGULO DE HÉLICE		FORMA B	35°	FORMA B	35°
	$L_1 \times L_2 \times D_2 \times \square$ mm	€	€	€	€
M 3x0,50	2,50 R 56 x 11 x 3,5 x 2,7	17,57	19,24	25,77	30,30
M 4x0,70	3,30 R 63 x 13 x 4,5 x 3,4	17,63	19,30	27,08	31,73
M 5x0,80	4,20 R 70 x 16 x 6,0 x 4,9	17,63	20,25	27,08	31,73
M 6x1,00	5,00 R 80 x 17 x 6,0 x 4,9	20,01	20,92	29,66	33,37
M 8x1,25	6,80 R 90 x 20 x 8,0 x 6,2	21,38	24,69	33,10	38,05
M 10x1,50	8,50 R 100 x 22 x 10,0 x 8,0	24,63	28,43	41,89	46,72
<b>MANGO DELGADO</b>		M2DMD	M4DMD	M2DMDTX	M4DMDTX
M 12x1,75	10,20 D 110 x 24 x 9,0 x 7,0	35,11	40,50	55,79	65,31
M 14x2,00	12,00 D 110 x 26 x 11,0 x 9,0	46,06	48,08	79,38	87,16
M 16x2,00	14,00 D 110 x 27 x 12,0 x 9,0	51,52	58,17	88,42	105,41
M 18x2,50	15,50 D 125 x 30 x 14,0 x 11,0	76,82	82,75	130,00	147,22
M 20x2,50	17,50 D 140 x 32 x 16,0 x 12,0	83,02	87,37	140,50	155,41

**MACHOS DE MÁQUINA PARA MATERIALES TEMPLADOS (HARDOX 450/500)**



TOL  
6H

HSSE

HSS  
PM

MD

MATERIALES  
MUY  
DUROS

48  
HRC

48-62  
HRC

Vc  
5 m/min

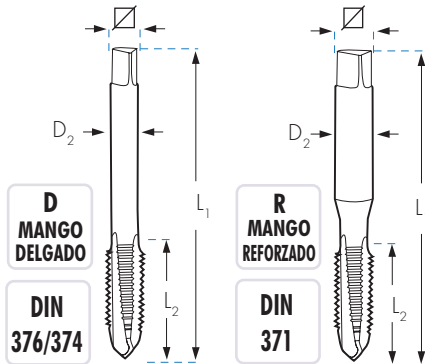

MD

Machos y Terrajas  
Rosa

MATERIAL		M2RC	M3RC	M2HRC	M4HRC	M1RCM		M1RHMC	
ACABADO		HSSE	HSSE	HSS PM	HSS PM	HSS PM		MD	
FORMA		TiAIN	TiAIN	TINALOX	TINALOX	TiCN		TiCN	
		FORMA B	FORMA B 15°	FORMA B	FORMA B 35°	FORMA C		FORMA C	
		€	€	€	€	€	€	€	€
M 2 x 0,40	1,60			34,07	37,25	1,70		1,70	
M 3 x 0,50	2,50	28,11	29,90	31,09	34,82	2,60	45,03	2,60	124,74
M 4 x 0,70	3,30	28,17	31,85	32,29	36,16	3,40	39,61	3,40	124,74
M 5 x 0,80	4,20	28,44	31,12	32,60	36,51	4,30	44,26	4,30	124,74
M 6 x 1,00	5,00	30,74	34,46	33,99	38,07	5,10	56,67	5,10	155,93
M 8 x 1,25	6,80	35,50	40,51	42,26	47,34	6,90	62,86	6,90	175,49
M 10 x 1,50	8,50	42,50	50,19	50,58	53,11	8,60	81,49	8,60	269,27
MANGO DELGADO		M2DC	M3DC	M2HDC	M4HDC	M1RCM		M1DHMC	
M 12 x 1,75	10,20	63,56	75,45	77,21	84,17	10,40	107,81*	10,40	421,71
M 14 x 2,00	12,00	85,82	100,38	91,56	102,98	12,10	136,30*	12,10	485,93
M 16 x 2,00	14,00	96,83	115,30	101,80	118,05	14,10	145,80*	16,10	634,52
M 18 x 2,50	15,50	122,62	133,52	126,02	137,36			15,75	775,19
M 20 x 2,50	17,50	148,50	154,56	148,82	162,22			17,75	1.226,22
M 22 x 2,50	19,50	210,36	219,36						
M 24 x 3,00	21,00	215,36	225,36	224,73	244,97				
M 27 x 3,00	24,00	235,36	242,36						
M 30 x 3,50	26,50	241,25	255,36						

\* Mango Reforzado: M12 - Ø 12 x 9  
M14 - Ø 14 x 11  
M16 - Ø 16 x 12





- Lubricación: **CUT MAGIC XTHICK**
- Se recomienda roscar la pieza sobre el mismo utillaje utilizado para el taladro previo y en la misma posición, para garantizar coaxialidad entre macho y orificio previo.

Ref. ACXT00250

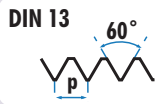
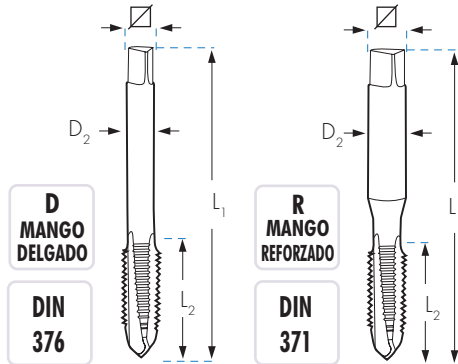
HRC	Vc (m/min)
48 Hrc	8 m/min
56 Hrc	6 m/min
62 Hrc	3 m/min

**MACHOS DE MÁQUINA TODO TERRENO**
**TODO  
TERRENO**

**HSSCo  
5%**
**TiN**
**TOL  
6H**
**APLICACIONES**
**1200  
N/mm<sup>2</sup>**
**Al**
**FUNDICIÓN**
**Ti**
**INOX**
**Vc  
13  
m/min**

		$L_1 \times L_2 \times D_2 \times \square$ mm	M2RD	M4RD
			FORMA B €	 35° €
M 3 x 0,50	2,50	R 56 x 11 x 3,5 x 2,7	26,39	32,99
M 4 x 0,70	3,30	R 63 x 13 x 4,5 x 3,4	28,24	32,99
M 5 x 0,80	4,20	R 70 x 16 x 6,0 x 4,9	30,04	34,17
M 6 x 1,00	5,00	R 80 x 17 x 6,0 x 4,9	31,09	35,47
M 8 x 1,25	6,80	R 90 x 20 x 8,0 x 6,2	36,42	40,47
M 10 x 1,50	8,50	R 100 x 22 x 10,0 x 8,0	42,02	47,94
<b>MANGO DELGADO</b>			<b>M2DD</b>	<b>M4DD</b>
M 12 x 1,75	10,20	D 110 x 24 x 9,0 x 7,0	52,95	63,04
M 14 x 2,00	12,00	D 110 x 26 x 11,0 x 9,0	69,15	75,99
M 16 x 2,00	14,00	D 110 x 27 x 12,0 x 9,0	77,49	83,87
M 18 x 2,50	15,50	D 125 x 30 x 14,0 x 11,0	121,09	124,17
M 20 x 2,50	17,50	D 140 x 32 x 16,0 x 12,0	123,34	127,96

**MACHOS DE MÁQUINA PARA TRABAJOS ESPECIALES HSSCo**

**Al**

**FUNDICIÓN**

**LATÓN**

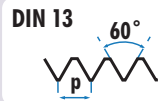

**HSSCo**  
5%

**MD**

**TOL**  
6H

**Vc**  
18 m/min

**Vc**  
11 m/min

**Vc**  
21 m/min

**Vc**  
16 m/min

**Vc**  
19 m/min

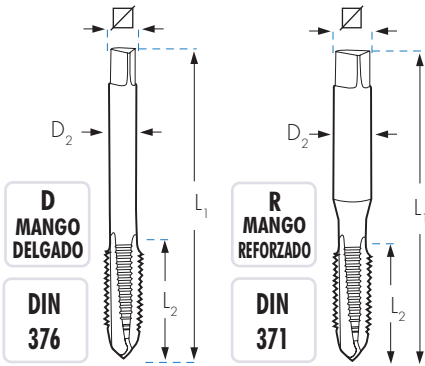

		M5R	M6R	MTRFM	MHMTR	M1RL	M1RLCRN	
APLICACIÓN		<b>Al</b>	<b>Al</b>	<b>FUNDICIÓN</b>	<b>FUNDICIÓN</b>	<b>LATÓN</b>	<b>LATÓN</b>	
MATERIAL		<b>HSSCo</b> 5%	<b>HSSCo</b> 5%	<b>HSSCo</b> 5%	<b>MD</b>	<b>HSSCo</b> 5%	<b>HSSCo</b> 5%	
ACABADO		BRILLANTE	BRILLANTE	<b>OX</b>	BRILLANTE	BRILLANTE	CrN	
FORMA		<b>DIENTE</b> <b>ALTERNO</b>	<b>2</b> <b>CANALES</b>	<b>FORMA</b> <b>C</b>	<b>FORMA</b> <b>C</b>	<b>FORMA</b> <b>C</b>	<b>FORMA</b> <b>C</b>	
		€	€	€	€	€	€	
	$L_1 \times L_2 \times D_2 \times \square$ mm							
M 3x0,50	2,50	R 56 x 11 x 3,5 x 2,7	22,77	24,43	16,11	81,66	19,29	21,91
M 4x0,70	3,30	R 63 x 13 x 4,5 x 3,4	22,90	24,43	16,65	81,66	20,48	24,15
M 5x0,80	4,20	R 70 x 16 x 6,0 x 4,9	22,77	24,95	16,65	81,66	20,48	24,24
M 6x1,00	5,00	R 80 x 17 x 6,0 x 4,9	24,00	26,98	18,91	93,14	22,44	26,47
M 8x1,25	6,80	R 90 x 20 x 8,0 x 6,2	28,73	32,33	21,18	104,00	25,59	32,18
M 10x1,50	8,50	R 100 x 22 x 10,0 x 8,0	34,64	38,23	24,23	130,34	30,78	39,16
<b>MANGO DELGADO</b>		M5D	M6D	M1DFM	MHM1D	M1DL	M1DLCRN	
M 12x1,75	10,20	D 110 x 24 x 9,0 x 7,0	44,03	48,05	31,05	181,83	36,59	48,22
M 14x2,00	12,00	D 110 x 26 x 11,0 x 9,0	79,73	82,98	51,04	283,26	44,92	58,76
M 16x2,00	14,00	D 110 x 27 x 12,0 x 9,0	86,90	94,10	60,05	336,99	51,68	65,70
M 18x2,50	15,50	D 125 x 30 x 14,0 x 11,0			84,00	413,09	67,78	83,21
M 20x2,50	17,50	D 140 x 32 x 16,0 x 12,0			84,33	500,23	76,08	92,64



- Lubricación: **CUT MAGIC ALUMINIO**
- Se recomienda la aplicación del Aceite de corte CUT MAGIC ALUMINIO para optimizar el proceso de roscado en Aluminio y sus fundiciones.

Ref. ACAL00250

**MACHOS DE MÁQUINA PARA ROSCADO POR LAMINACIÓN**

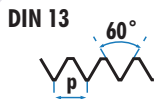
**LAMINACIÓN**

**DIN 13**
**60°**
**HSSCo**  
**5%**
**HSSCo**  
**8%**
**TOL**  
**6HX**
**APLICACIONES**

**800**  
**N/mm²**

**Al**

**FUNDICIÓN**

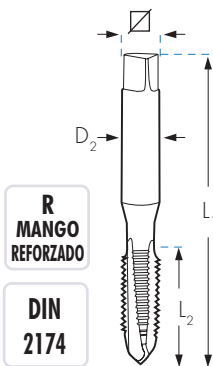
**1400**  
**N/mm²**
*Plus*

**INOX**

**R**  
**MANGO**  
**REFORZADO**
**DIN**  
**2174**

		M07R	M07RT	M07RCR	M07RCCR	M09RCCR	M07RXTCR
APLICACIÓN							
MATERIAL		HSSCo 5%	HSSCo 5%	HSSCo 5%	HSSCo 5%	HSSCo 8%	HSSCo 5%
ACABADO		OX	TiN	OX	TiCN	TiCN	TiN
FORMA							
	$L_1 \times L_2 \times D_2 \times \square$ mm	€	€	€	€	€	€
M 3x0,50	2,75 R 56 x 11 x 3,5 x 2,7	32,21	34,97	35,45	44,48	107,01	79,80
M 3,5x0,60	3,20 R 56 x 11 x 3,5 x 2,7	33,86	38,56	36,62	47,08		
M 4x0,70	3,65 R 63 x 13 x 4,5 x 3,4	32,21	36,47	35,45	46,39	108,36	79,80
M 5x0,80	4,60 R 70 x 16 x 6,0 x 4,9	32,21	36,47	35,45	46,39	109,80	86,12
M 6x1,00	5,50 R 80 x 17 x 6,0 x 4,9	34,78	38,54	38,25	49,03	111,54	86,12
M 8x1,25	7,40 R 90 x 20 x 8,0 x 6,2	40,53	50,87	44,59	64,73	123,73	103,07
M 10x1,50	9,30 R 100 x 22 x 10,0 x 8,0	45,08	57,04	49,60	71,24	147,73	125,83

		M07D	M07DT	M07DCR	M07DCCR	M09DCCR	M07DXTCR
<b>MANGO DELGADO</b>							
M 12x1,75	11,20 D 110 x 24 x 9,0 x 7,0	53,13	74,59	56,28	81,58	174,88	163,86
M 14x2,00	13,05 D 110 x 26 x 11,0 x 9,0	95,78	117,80	99,50	132,44	217,64	235,72
M 16x2,00	15,05 D 110 x 27 x 12,0 x 9,0	112,44	132,68	116,79	140,20	299,33	239,81
M 18x2,50	16,80 D 125 x 30 x 14,0 x 11,0	129,03	158,65	134,02	165,66	354,67	
M 20x2,50	18,80 D 140 x 32 x 16,0 x 12,0	170,01	240,16	176,60	251,84	392,66	

MACHOS DE MÁQUINA HSSCo TOLERANCIAS ESPECIALES Y SOBREMEDIDAS



		M2R4H	M4R4H	M2R6G	M4R6G	M2R7G	M4R7G	M2R+0,1	M4R+0,1	M2R+0,2	M4R+0,2
		TOL 4H	TOL 4H	TOL 6G	TOL 6G	TOL 7G	TOL 7G	TOL 6H (+0,1)	TOL 6H (+0,1)	TOL 6H (+0,2)	TOL 6H (+0,2)
		HSSCo 5%	HSSCo 5%	HSSCo 5%	HSSCo 5%	HSSCo 5%	HSSCo 5%	HSSCo 5%	HSSCo 5%	HSSCo 5%	HSSCo 5%
		BRILLANTE	BRILLANTE	BRILLANTE	BRILLANTE	BRILLANTE	BRILLANTE	BRILLANTE	BRILLANTE	BRILLANTE	BRILLANTE
		FORMA B	FORMA B 35°	FORMA B	FORMA B 35°	FORMA B	FORMA B 35°	FORMA B	FORMA B 35°	FORMA B	FORMA B 35°
L <sub>1</sub> x L <sub>2</sub> x D <sub>2</sub> x ∅		€	€	€	€	€	€	€	€	€	€
M 3x0,50	2,50 R 56x11x 3,5x 2,7	22,04	27,25	16,17	19,24	22,04	27,25	22,75	30,35	26,10	32,32
M 4x0,70	3,30 R 63x13x 4,5x 3,4	22,55	27,25	16,17	19,24	22,55	27,25	23,29	30,35	26,70	32,32
M 5x0,80	4,20 R 70x16x 6,0x 4,9	22,55	26,11	16,17	18,88	22,55	26,11	23,29	29,07	26,70	30,94
M 6x1,00	5,00 R 80x17x 6,0x 4,9	24,78	28,65	17,41	20,73	24,78	28,65	25,57	31,90	29,35	33,96
M 8x1,00	7,00 D 90x20x 6,0x 4,9			33,90	37,49						
M 8x1,25	6,75 R 90x20x 8,0x 6,2	27,75	32,71	20,24	24,30	27,75	32,71	28,65	36,40	32,88	38,77
M 10x1,00	9,00 D 90x16x 7,0x 5,5			40,04	46,60						
M 10x1,50	8,50 R 100x22x 10,0x 8,0	34,12	38,83	24,90	27,79	34,12	38,83	35,25	43,17	40,46	45,96
MANGO DELGADO		M2D4H	M4D4H	M2D6G	M4D6G	M2D7G	M4D7G	M2D+0,1	M4D+0,1	M2D+0,2	M4D+0,2
M 12x1,50	10,50 D 100x22x 9,0x 7,0			72,95	86,49						
M 12x1,75	10,20 D 110x24x 9,0x 7,0	44,00	52,24	32,84	39,56	44,00	52,24	44,14	55,96	50,15	59,59
M 14x2,00	12,00 D 110x26x 11,0x 9,0			40,34	48,47			72,01	89,08	81,83	94,87
M 16x2,00	14,00 D 110x27x 12,0x 9,0			49,86	58,54			84,69	107,65	96,27	114,64
M 18x2,50	15,50 D 125x30x 14,0x 11,0			70,31	72,48			128,06	144,99	136,36	154,39
M 20x2,50	17,50 D 140x32x 16,0x 12,0			72,62	83,31			138,37	154,28	147,34	164,29

- 4H.- Para roscas muy precisas. Ajuste más exacto.
- 6G.- Para roscas con recubrimientos. Espesores entre 20 - 40 μ
- 7G.- Para roscas con recubrimientos. Espesores entre 40 - 50 μ
- 6H. (+0,1)- Hay que añadir 0,10mm a la broca previa.
- 6H. (+0,2)- Hay que añadir 0,20mm a la broca previa.

**MACHOS DE MÁQUINA EXTRALARGOS HSSCo**
**FORMA  
B**

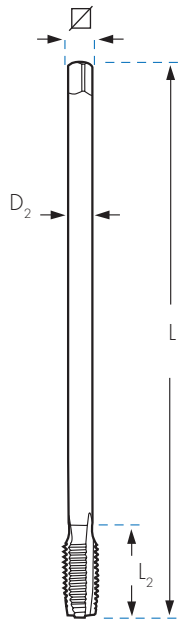
**HSSCo  
5%**
**BRILLANTE**
**TOL  
6H**
**R  
MANGO  
REFORZADO**
**DIN  
371**
**D  
MANGO  
DELGADO**
**DIN  
376**

				M2L
			$L_1 \times L_2 \times D_2 \times \square$ mm	FORMA B €
M	3x0,50	2,50	R 100 x 10 x 3,5 x 2,7	36,79
M	4x0,70	3,30	R 120 x 12 x 4,5 x 3,4	37,60
M	5x0,80	4,20	R 140 x 14 x 6,0 x 4,9	37,60
M	6x1,00	5,00	R 160 x 16 x 6,0 x 4,9	41,31
M	7x1,00	6,00	R 160 x 17 x 7,0 x 5,5	46,92
M	8x1,25	6,80	R 180 x 18 x 8,0 x 6,2	48,44

**MANGO DELGADO**

				M2L-D
M		D		€
M	6x1,00	5,00	D 160 x 16 x 4,5 x 3,4	42,89
M	8x1,25	6,80	D 180 x 18 x 6,2 x 5,0	50,32
M	10x1,50	8,50	D 200 x 20 x 7,0 x 5,5	59,63
M	12x1,75	10,20	D 220 x 22 x 8,5 x 6,5	73,37
M	14x2,00	12,00	D 220 x 25 x 10,5 x 8,0	113,86
M	16x2,00	14,00	D 220 x 28 x 12,5 x 10,0	133,94
M	18x2,50	15,50	D 250 x 32 x 14,0 x 11,0	243,71
M	20x2,50	17,50	D 250 x 32 x 16,0 x 12,0	263,40
M	22x2,50	19,50	D 250 x 35 x 18,0 x 14,5	300,30
M	24x3,00	21,00	D 250 x 38 x 18,0 x 14,5	367,21

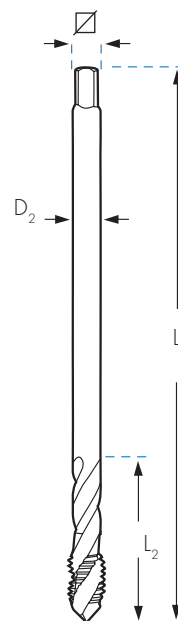
**HSSCo  
5%**
**BRILLANTE**
**TOL  
6H**
**R  
MANGO  
REFORZADO**
**DIN  
371**
**D  
MANGO  
DELGADO**
**DIN  
376**

				M4L
			$L_1 \times L_2 \times D_2 \times \square$ mm	 €
M	3x0,50	2,50	R 100 x 10 x 3,5 x 2,7	45,52
M	4x0,70	3,30	R 120 x 12 x 4,5 x 3,4	45,52
M	5x0,80	4,20	R 140 x 14 x 6,0 x 4,9	43,61
M	6x1,00	5,00	R 160 x 16 x 6,0 x 4,9	47,84
M	7x1,00	6,00	R 160 x 17 x 7,0 x 5,5	54,31
M	8x1,25	6,80	R 180 x 18 x 8,0 x 6,2	58,13

**MANGO DELGADO**

				M4L-D
M		D		€
M	6x1,00	5,00	D 160 x 16 x 4,5 x 3,4	49,70
M	8x1,25	6,80	D 180 x 18 x 6,2 x 5,0	59,19
M	10x1,50	8,50	D 200 x 20 x 7,0 x 5,5	67,37
M	12x1,75	10,20	D 220 x 22 x 8,5 x 6,5	87,15
M	14x2,00	12,00	D 220 x 25 x 10,5 x 8,0	127,58
M	16x2,00	14,00	D 220 x 28 x 12,5 x 10,0	184,89
M	18x2,50	15,50	D 250 x 32 x 14,0 x 11,0	275,95
M	20x2,50	17,50	D 250 x 32 x 16,0 x 12,0	293,69
M	22x2,50	19,50	D 250 x 35 x 18,0 x 14,5	328,99
M	24x3,00	21,00	D 250 x 38 x 18,0 x 14,5	375,04



**MACHO TUERQUERO DE ROSCA MÉTRICA DIN 357**



**HSSCo**  
**5%**

**BRILLANTE**

**TOL**  
**6H**

**DIN**  
**357**

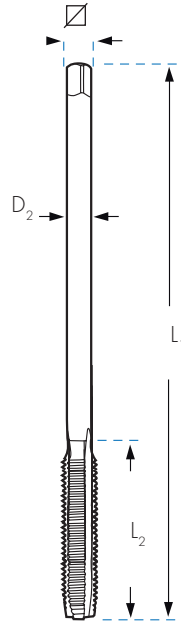

				MTU	
				FORMA	
				A	€
		L <sub>1</sub> x L <sub>2</sub> x D <sub>2</sub> x $\square$ mm			
M	3x0,50**	2,50	D 70 x 22 x 2,2		24,13
M	4x0,70	3,30	D 90 x 25 x 2,8 x 2,1		24,13
M	5x0,80	4,20	D 100 x 28 x 3,5 x 2,7		24,13
M	6x1,00	5,00	D 110 x 32 x 4,5 x 3,4		24,13
M	8x1,25	6,80	D 125 x 40 x 6,0 x 4,9		29,09
M	10x1,50	8,50	D 140 x 45 x 7,0 x 5,5		28,43
M	12x1,75	10,20	D 180 x 50 x 9,0 x 7,0		34,43
M	14x2,00	12,00	D 200 x 56 x 11,0 x 9,0		54,41
M	16x2,00	14,00	D 200 x 63 x 12,0 x 9,0		67,36
M	18x2,50	15,50	D 220 x 63 x 14,0 x 11,0		90,62
M	20x2,50	17,50	D 250 x 70 x 16,0 x 12,0		127,93*
M	22x2,50	19,50	D 280 x 80 x 18,0 x 14,5		156,96*
M	24x3,00	21,00	D 280 x 80 x 18,0 x 14,5		213,57*

\*\* Mango cilíndrico

\*Hasta fin de existencias

Machos y Terrajas

Rosa

**BLUE-MASTER**  
by CELESA

CONSULTE NUESTRA AMPLIA GAMA DE HERRAMIENTAS  
PARA LA REPARACIÓN DE ROSCAS Pág. 659



**INSERTOS**  
**LIBRES**

**INSERTOS SÓLIDOS**  
**CON SELLADOR ANAERÓBICO**

**INSERTOS**  
**AUTORROSCANTES**

**CASQUILLOS ROSCADOS**  
**DE SEGURIDAD**

**BROCA MACHO HSSCo**

DIN 13

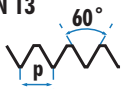
**HSSCo**  
**5%**

BRILLANTE

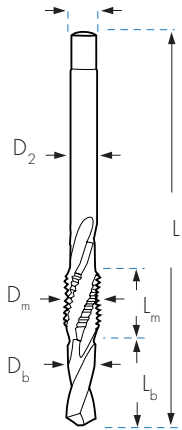
**TOL**  
**6H**
**R**  
**MANGO**  
**REFORZADO**
**DIN**  
**371**
**D**  
**MANGO**  
**DELGADO**
**DIN**  
**376**

		L <sub>b</sub> mm	L <sub>m</sub> mm	L <sub>1</sub> mm	D <sub>b</sub> mm	D <sub>m</sub> mm	D <sub>2</sub> mm	∅ mm	M8M €
M 3x0,50	R	9,0	12,5	62,0	2,50	3,0	3,5	2,7	36,99
M 4x0,70	R	10,0	16,0	66,0	3,30	4,0	4,5	3,4	36,99
M 5x0,80	R	12,5	18,0	75,5	4,20	5,0	6,0	4,9	38,44
M 6x1,00	R	14,0	20,0	81,0	5,00	6,0	6,0	4,9	42,45
M 8x1,00	R	20,0	14,0	91,0	7,00	8,0	6,0	4,9	49,83
M 8x1,25	R	20,0	14,0	91,0	6,75	8,0	8,0	6,2	47,86

**MANGO DELGADO**

M 8x1,25	D	20,0	14,0	91,0	6,75	8,0	6,0	4,9	51,70
M 10x1,00	D	20,0	15,0	95,0	9,00	10,0	7,0	5,5	61,85
M 10x1,50	D	25,0	18,0	105,0	8,50	10,0	7,0	5,5	65,65
M 12x1,50	D	24,0	18,0	110,0	10,50	12,0	9,0	7,0	71,65
M 12x1,75	D	28,0	20,0	118,0	10,20	12,0	9,0	7,0	71,23
M 14x1,50	D	28,0	20,0	118,0	12,50	14,0	11,0	9,0	113,38
M 14x2,00	D	28,0	22,0	130,0	12,00	14,0	11,0	9,0	128,96
M 16x2,00	D	36,0	24,0	139,0	14,00	16,0	12,0	9,0	169,61
M 18x2,50	D	40,0	26,0	151,0	15,50	18,0	14,0	11,0	247,38
M 20x2,50	D	45,0	30,0	168,0	17,50	20,0	16,0	12,0	355,26

Nota: Jamás emplee los Broca-Machos en agujeros ciegos o en pasantes más profundos que L<sub>b</sub>

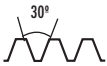
**MACHO DE MÁQUINA ROSCA TRAPEZOIDAL HSS**

**HSS**

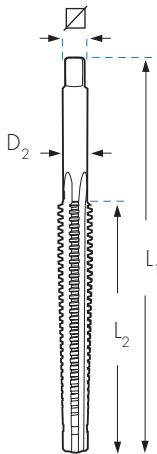
BRILLANTE

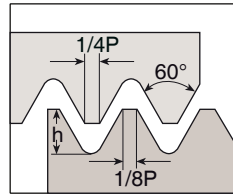
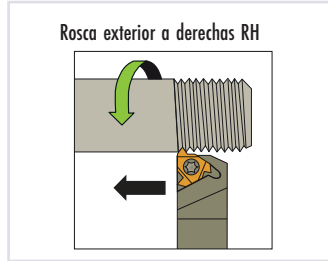
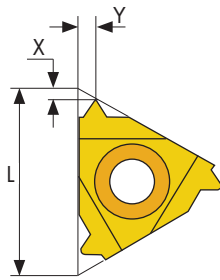

**DIN**  
**103**
**TOL**  
**7H**

		∅	L <sub>1</sub> x L <sub>2</sub> x D <sub>2</sub> x ∅ mm	MRTM €
Tr 14 x 3		11,25	160 x 105 x 10,5 x 8,0	570,43
Tr 16 x 4		12,25	205 x 110 x 11,5 x 9,0	593,84
Tr 18 x 4		14,25	215 x 120 x 13,0 x 10,0	626,00
Tr 20 x 4		16,25	230 x 130 x 15,0 x 12,0	628,93
Tr 22 x 5		17,25	270 x 165 x 16,0 x 12,0	827,86
Tr 24 x 5		19,25	280 x 165 x 18,0 x 14,5	939,03
Tr 26 x 5		21,25	290 x 170 x 20,0 x 16,0	971,60
Tr 28 x 5		23,25	300 x 180 x 22,0 x 18,0	1.100,61
Tr 30 x 6		24,25	345 x 200 x 23,0 x 18,0	1.266,65

PLAQUITAS PARA ROSCADO DE EXTERIORES

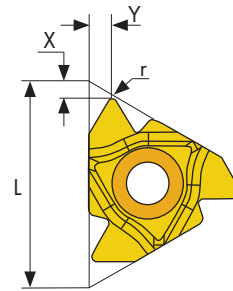

Norma: R262 (DIN 13)  
Tolerancia clase: 6g/6H



Perfil Total

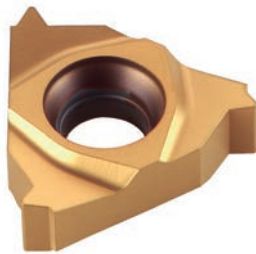
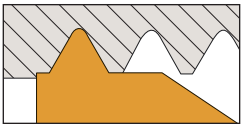

Perfil Parcial

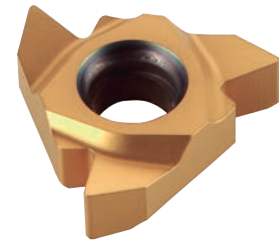
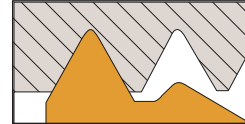

Rosca el perfil completo, terminando el diámetro exterior de la rosca.  
Utilizaremos una plaquita diferente para cada paso.

No termina el diámetro exterior de la rosca.  
La misma plaquita puede ser utilizada para una gama de diferentes pasos, que tengan el mismo ángulo de rosca.

PERFIL TOTAL 60°

ROSCADO EXTERIOR	L	PASO	h	X	Y	€
PRE-16-075	16	0,75	0,46	0,6	0,6	25,56*
PRE-16-100		1,00	0,61	0,7	0,7	25,56*
PRE-16-125		1,25	0,77	0,8	0,9	25,56*
PRE-16-150		1,50	0,92	0,8	1	25,56*
PRE-16-175		1,75	1,07	0,9	1,2	25,56*
PRE-16-200		2,00	1,23	1	1,3	25,56*
PRE-16-250		2,50	1,53	1,1	1,5	25,56*
PRE-16-300		3,00	1,84	1,2	1,6	25,56*

\*Hasta fin de existencias

PERFIL PARCIAL 60°

ROSCADO EXTERIOR	L	RANGOS MÉTRICOS	RANGO PULGADAS	r	X	Y	€
PPRE-16-150	16	0,50-1,50	48 - 16	0,05	0,80	0,90	25,56*
PPRE-16-300		1,75-3,00	14 - 8	0,27	1,20	1,70	25,56*

\*Hasta fin de existencias

PORTAHERRAMIENTAS DE ROSCADO DE EXTERIORES

ROSCADO EXTERIOR	H1=H=B=F	L1	L2	€
PEXT-25-16	25	153	30	186,87*

\*Hasta fin de existencias

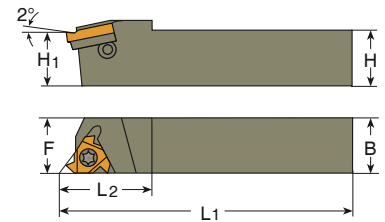

FÓRMULA MATEMÁTICA PARA OBTENER LA VELOCIDAD DE GIRO DE LA PIEZA (RPM)

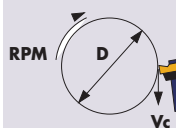

$$RPM = \frac{1000 \times Vc}{\pi \times D}$$

RPM: Revoluciones x minuto  
Vc: Velocidad de Corte (m/min)  
D: Diámetro Pieza (mm)

Las RPM-s se Obtienen en función de Vc y D

ACERO BLANDO 70 kg/mm <sup>2</sup>	Vc 25 m / min	ALUMINIO	Vc 50 m / min
ACERO TRATADO 120 kg/mm <sup>2</sup>	13 m / min	TITANIO	18 m / min
INOXIDABLE	11 m / min	FUNDICIÓN	25 m / min
		LATÓN	50 m / min

**PLAQUITAS PARA ROSCADO DE INTERIORES**

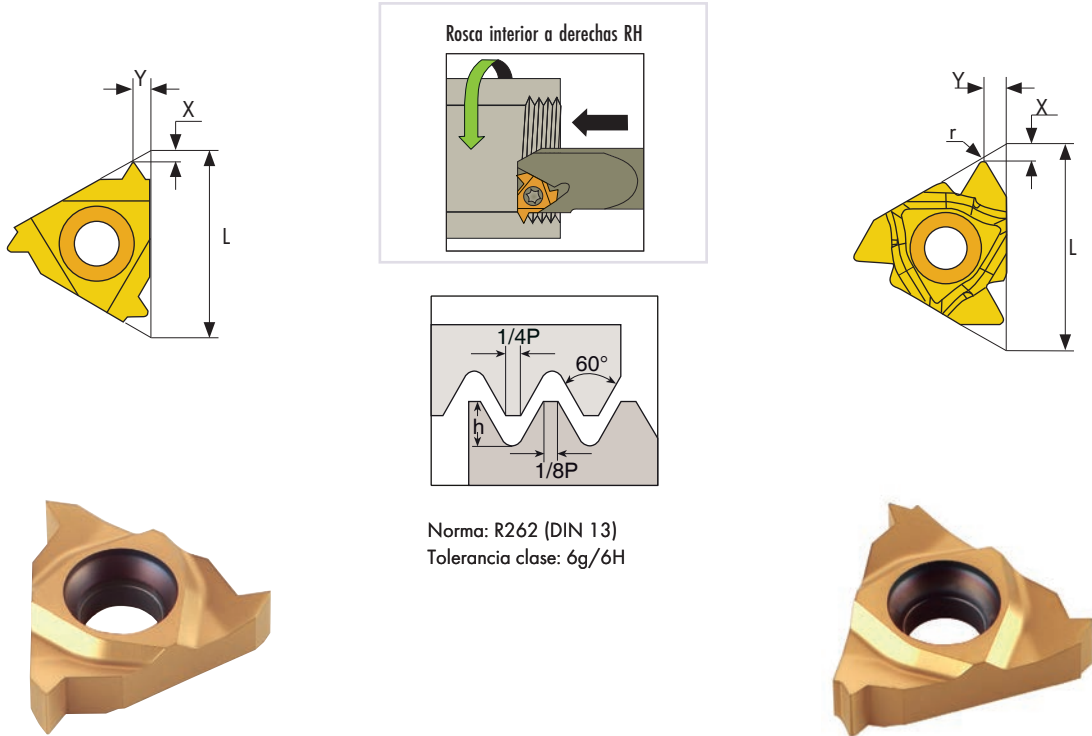

Norma: R262 (DIN 13)  
Tolerancia clase: 6g/6H

**PERFIL TOTAL 60°**

ROSCADO INTERIOR	L	PASO	h	X	Y	€
PRI-16-075	16	0,75	0,43	0,6	0,6	25,56*
PRI-16-100		1,00	0,58	0,6	0,7	25,56*
PRI-16-125		1,25	0,72	0,8	0,9	25,56*
PRI-16-150		1,50	0,87	0,8	1,0	25,56*
PRI-16-175		1,75	1,01	0,9	1,2	25,56*
PRI-16-200		2,00	1,15	1,0	1,3	25,56*
PRI-16-250		2,50	1,44	1,1	1,5	25,56*
PRI-16-300		3,00	1,73	1,1	1,5	25,56*

\*Hasta fin de existencias

**PERFIL PARCIAL 60°**

ROSCADO INTERIOR	L	RANGOS MÉTRICOS	RANGO PULGADAS	r	X	Y	€
PPRI-16-150	16	0,50-1,50	48 - 16	0,05	0,80	0,90	25,56*
PPRI-16-300		1,75-3,00	14 - 8	0,16	1,20	1,70	25,56*

\*Hasta fin de existencias

**PORTAHERRAMIENTAS DE ROSCADO DE INTERIORES**

ROSCADO INTERIOR	L	L1	D	D1	A	Ø Mín. agujero	€
PINT-20-16	180	40	20	20	18	24	184,18*
PINT-25-16	200	45	25	24,6	22,6	29	225,20*

\*Hasta fin de existencias

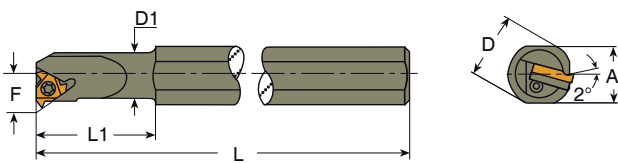

**MACHOS DE MÁQUINA HSSCo EN ESTUCHES METÁLICOS**

**USO**  
GENERAL

**HSSCo**  
5%



Ref. JM6



Ref. JM2



Ref. JM8



Ref. JM4

**CONTENIDO**



	FORMA C	FORMA B	15°	35°	HSS	HSSCo 5% €
JM5	M3 - M4 - M5 - M6 M8 - M10 - M12	-	-	-	-	106,49
JM1	M3 - M4 - M5 - M6 M8 - M10 - M12	-	-	-	2.5 / 3.3 / 4.2 / 5.0 6.8 / 8.5 / 10.2 mm	127,37
JM6	-	M3 - M4 - M5 - M6 M8 - M10 - M12	-	-	-	113,46
JM2	-	M3 - M4 - M5 - M6 M8 - M10 - M12	-	-	2.5 / 3.3 / 4.2 / 5.0 6.8 / 8.5 / 10.2 mm	127,60
JM7	-	-	M3 - M4 - M5 - M6 M8 - M10 - M12	-	-	141,35
JM3	-	-	M3 - M4 - M5 - M6 M8 - M10 - M12	-	2.5 / 3.3 / 4.2 / 5.0 6.8 / 8.5 / 10.2 mm	168,90
JM8	-	-	-	M3 - M4 - M5 - M6 M8 - M10 - M12	-	143,79
JM4	-	-	-	M3 - M4 - M5 - M6 M8 - M10 - M12	2.5 / 3.3 / 4.2 / 5.0 6.8 / 8.5 / 10.2 mm	167,10

**MACHOS DE MÁQUINA EN ESTUCHES METÁLICOS**



Ref. JMPT2

**CONTENIDO**

	FORMA B	BRILLANTE	 35°	BRILLANTE	 HSSCo 5%	HSS PM €		TiN €
JMP6	M3 - M4 - M5 - M6 M8 - M10 - M12		-		-	118,23	JMPT6	170,52
JMP2	M3 - M4 - M5 - M6 M8 - M10 - M12		-		2.5 / 3.3 / 4.2 / 5.0 6.8 / 8.5 / 10.2 mm	155,05	JMPT2	207,48
JMP8	-		M3 - M4 - M5 - M6 M8 - M10 - M12		-	170,52	JMPT8	187,81
JMP4	-		M3 - M4 - M5 - M6 M8 - M10 - M12		2.5 / 3.3 / 4.2 / 5.0 6.8 / 8.5 / 10.2 mm	207,48	JMPT4	224,89

**INOX**
**CONTENIDO**

	FORMA B	OX	 35°	OX	 HSSCo 5%	HSS PM €		TiN €
JMX6	M3 - M4 - M5 - M6 M8 - M10 - M12		-		-	152,53	JMXT6	166,39
JMX2	M3 - M4 - M5 - M6 M8 - M10 - M12		-		2.5 / 3.3 / 4.2 / 5.0 6.8 / 8.5 / 10.2 mm	189,50	JMXT2	203,36
JMX8	-		M3 - M4 - M5 - M6 M8 - M10 - M12		-	174,07	JMXT8	191,90
JMX4	-		M3 - M4 - M5 - M6 M8 - M10 - M12		2.5 / 3.3 / 4.2 / 5.0 6.8 / 8.5 / 10.2 mm	211,02	JMXT4	228,85

**CONTENIDO**

	FORMA B	OX	 35°	OX	 HSSCo 5%	HSS V3 €		TINALOX €
JMMD6	M3 - M4 - M5 - M6 M8 - M10 - M12		-		-	138,65	JMMDT6	196,84
JMMD2	M3 - M4 - M5 - M6 M8 - M10 - M12		-		2.5 / 3.3 / 4.2 / 5.0 6.8 / 8.5 / 10.2 mm	175,61	JMMDT2	233,79
JMMD8	-		M3 - M4 - M5 - M6 M8 - M10 - M12		-	158,24	JMMDT8	226,98
JMMD4	-		M3 - M4 - M5 - M6 M8 - M10 - M12		2.5 / 3.3 / 4.2 / 5.0 6.8 / 8.5 / 10.2 mm	195,19	JMMDT4	263,93

**MACHOS DE MÁQUINA EN ESTUCHES METÁLICOS**

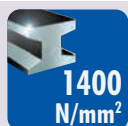

Ref. JMC2

**CONTENIDO**

	FORMA B	TiCN	15°	TiCN	HSSCo 5%	HSS-PM €
JMC6	M3 - M4 - M5 - M6 M8 - M10 - M12		-		-	235,86
JMC2	M3 - M4 - M5 - M6 M8 - M10 - M12		-		2.5 / 3.3 / 4.2 / 5.0 6.8 / 8.5 / 10.2 mm	272,82
JMC8	-		M3 - M4 - M5 - M6 M8 - M10 - M12		-	268,47
JMC4	-		M3 - M4 - M5 - M6 M8 - M10 - M12		2.5 / 3.3 / 4.2 / 5.0 6.8 / 8.5 / 10.2 mm	305,43

**TODO  
TERRENO**

**CONTENIDO**

	FORMA B	TiN	35°	TiN	HSSCo 5%	HSSCo 5% €
JMD6	M3 - M4 - M5 - M6 M8 - M10 - M12		-		-	213,14
JMD2	M3 - M4 - M5 - M6 M8 - M10 - M12		-		2.5 / 3.3 / 4.2 / 5.0 6.8 / 8.5 / 10.2 mm	250,10
JMD8	-		M3 - M4 - M5 - M6 M8 - M10 - M12		-	240,36
JMD4	-		M3 - M4 - M5 - M6 M8 - M10 - M12		2.5 / 3.3 / 4.2 / 5.0 6.8 / 8.5 / 10.2 mm	277,32

**AI**

**CONTENIDO**

	DIENTE ALTERNO	BRILLANTE	2 CANALES	BRILLANTE	HSS	HSSCo 5% €
JMAL6	M3 - M4 - M5 - M6 M8 - M10 - M12		-		-	168,76
JMAL2	M3 - M4 - M5 - M6 M8 - M10 - M12		-		2.5 / 3.3 / 4.2 / 5.0 6.8 / 8.5 / 10.2 mm	205,71
JMAL8	-		M3 - M4 - M5 - M6 M8 - M10 - M12		-	166,88
JMAL4	-		M3 - M4 - M5 - M6 M8 - M10 - M12		2.5 / 3.3 / 4.2 / 5.0 6.8 / 8.5 / 10.2 mm	203,84

**MACHOS DE MÁQUINA EN ESTUCHES**
**USO  
GENERAL**
**CONTENIDO**

	FORMA B	BRILLANTE	 35°	BRILLANTE	HSSCo 5% €
PT01	M4 - M5 - M6 M8 - M10		M4 - M5 - M6 M8 - M10		129,44



Ref. PT01

**Plus**
**CONTENIDO**

	FORMA B	BRILLANTE	 35°	BRILLANTE	HSS PM €	TiN €
PT02	M4 - M5 - M6 M8 - M10		M4 - M5 - M6 M8 - M10		162,83	PT03 239,13



Ref. PT03

**INOX**
**CONTENIDO**

	FORMA B	OX	 35°	OX	HSS PM €	TiN €
PT05	M4 - M5 - M6 M8 - M10		M4 - M5 - M6 M8 - M10		213,95	PT13 227,69



Ref. PT05

**CONTENIDO**

	FORMA B	OX	 35°	OX	HSS V3 €	TINALOX €
PT04	M4 - M5 - M6 M8 - M10		M4 - M5 - M6 M8 - M10		183,61	PT14 275,93



Ref. PT04

**CONTENIDO**

	FORMA B	TiCN	 15°	TiCN	HSS PM €
PT11	M4 - M5 - M6 M8 - M10		M4 - M5 - M6 M8 - M10		332,64



Ref. PT11



**MACHOS DE MÁQUINA EN ESTUCHES**

**Al**



Ref. PT06

**CONTENIDO**

	DIENTE ALTERNO	2 CANALES	HSSCo 5% €
PT06	M4 - M5 - M6 M8 - M10	M4 - M5 - M6 M8 - M10	202,99

**FUNDICIÓN**



Ref. PT07

**CONTENIDO**

	FORMA C	HSSCo 5% €
PT07	M4 - M5 - M6 - M8 - M10 M4 - M5 - M6 - M8 - M10	153,41

**LATÓN**



Ref. PT10

**CONTENIDO**

	FORMA C	HSSCo 5% €
PT10	M4 - M5 - M6 - M8 - M10 M4 - M5 - M6 - M8 - M10	186,49



**LAMINACIÓN**



Ref. PT08

**CONTENIDO**

		HSSCo 5% €
PT08	M4 - M5 - M6 - M8 - M10 M4 - M5 - M6 - M8 - M10	280,77



Ref. PT09

**CONTENIDO**

		HSSCo 5% €
PT09	M4 - M5 - M6 - M8 - M10 M4 - M5 - M6 - M8 - M10	378,25

**TOL 6G**



Ref. PT12

**CONTENIDO**

	FORMA B	 35°	HSSCo 5% €
PT12	M4 - M5 - M6 M8 - M10	M4 - M5 - M6 M8 - M10	209,75

**EXPOSITORES DE METACRILATO PARA MACHOS DE MÁQUINA**
**EXPOSITOR DE METACRILATO**

MM-03

Composición: Machos de máquina, Serie Normal

**HSSCo**  
**5%**
**FORMA**

Agujeros pasantes, Ref. M2

**B**

<u>M4</u>	<u>M5</u>	<u>M6</u>	<u>M8</u>	<u>M10</u>	<u>M12</u>	<u>M14</u>
5	10	10	10	10	5	4

Agujeros ciegos, Ref. M4

**35°**

<u>M4</u>	<u>M5</u>	<u>M6</u>	<u>M8</u>	<u>M10</u>	<u>M12</u>	<u>M14</u>
5	10	10	10	10	5	4

Dimensiones: ancho 240 x fondo 240 x alto 245 mm

1.992,33 €



Ref. MM-03



Ref. MM-04

**EXPOSITOR DE METACRILATO**

MM-04

Composición: Machos de máquina, Serie Plus  
Fabricados en Acero sinterizado PM
**HSS**  
**PM**
*Plus*
**FORMA**

Agujeros pasantes, Ref. M2

**B**

<u>M4</u>	<u>M5</u>	<u>M6</u>	<u>M8</u>	<u>M10</u>	<u>M12</u>	<u>M14</u>
5	10	10	10	10	5	4

**35°**

Agujeros ciegos, Ref. M4

<u>M4</u>	<u>M5</u>	<u>M6</u>	<u>M8</u>	<u>M10</u>	<u>M12</u>	<u>M14</u>
5	10	10	10	10	5	4

Dimensiones: ancho 240 x fondo 240 x alto 245 mm

2.718,13 €

**EXPOSITOR DE METACRILATO**

MM-05

Composición: Machos de máquina para trabajos especiales

**FORMA**
**B**

Agujeros pasantes, Ref. M2

**1200**  
**N/mm<sup>2</sup>**

<u>M4</u>	<u>M5</u>	<u>M6</u>	<u>M8</u>	<u>M10</u>	<u>M12</u>	<u>M14</u>
1	2	2	2	2	1	1

**INOX**

<u>M4</u>	<u>M5</u>	<u>M6</u>	<u>M8</u>	<u>M10</u>	<u>M12</u>	<u>M14</u>
1	2	2	2	2	1	1

**Al**

<u>M4</u>	<u>M5</u>	<u>M6</u>	<u>M8</u>	<u>M10</u>	<u>M12</u>	<u>M14</u>
1	2	2	2	2	1	1

**TiN**

<u>M4</u>	<u>M5</u>	<u>M6</u>	<u>M8</u>	<u>M10</u>	<u>M12</u>	<u>M14</u>
1	2	2	2	2	1	1

**1400**  
**N/mm<sup>2</sup>**

<u>M4</u>	<u>M5</u>	<u>M6</u>	<u>M8</u>	<u>M10</u>	<u>M12</u>
1	2	2	2	2	1

**35°**

Agujeros ciegos, Ref. M4

**1200**  
**N/mm<sup>2</sup>**

<u>M4</u>	<u>M5</u>	<u>M6</u>	<u>M8</u>	<u>M10</u>	<u>M12</u>	<u>M14</u>
1	2	2	2	2	1	1

**INOX**

<u>M4</u>	<u>M5</u>	<u>M6</u>	<u>M8</u>	<u>M10</u>	<u>M12</u>	<u>M14</u>
1	2	2	2	2	1	1

**Al**

<u>M4</u>	<u>M5</u>	<u>M6</u>	<u>M8</u>	<u>M10</u>	<u>M12</u>	<u>M14</u>
1	2	2	2	2	1	1

**TiN**

<u>M4</u>	<u>M5</u>	<u>M6</u>	<u>M8</u>	<u>M10</u>	<u>M12</u>	<u>M14</u>
1	2	2	2	2	1	1

**1400**  
**N/mm<sup>2</sup>**

<u>M4</u>	<u>M5</u>	<u>M6</u>	<u>M8</u>	<u>M10</u>	<u>M12</u>
1	2	2	2	2	1

Dimensiones: ancho 240 x fondo 240 x alto 245 mm

3.395,23 €