

MASCHI E FILIERE



BLUE-MASTER[®]
by celesa

CUTTING TECHNOLOGIES

SERIE DI MASCHI E FILIERE PER FILETTARE A MANO HSS

M
MF

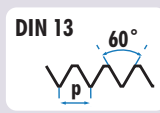

DIN 13 60°

Ref. M0

HSS

DIN 352

DIN 2181

TOL 6H

Ref. C5

HSS

DIN 223

TOL 6g

Per materiali fino a 38 HRC.



		M0			C5	
	U.tà	$L_1 \times L_2 \times \nabla$ mm	€	$\emptyset \times L_3$ mm	€	
M 5,5x0,90	3	4,60	50 x 16 x 4,9	83,48	25 x 9	23,66
M 6x0,50	2	5,50	50 x 14 x 4,9	26,96	20 x 5	29,14
M 6x0,75	2	5,25	50 x 14 x 4,9	22,71	25 x 9	26,09
M 6x1,00	3	5,00	50 x 19 x 4,9	16,60*	25 x 9	18,38*
M 6x1,25	3	4,75	50 x 19 x 4,9	130,44	25 x 9	103,17
M 7x0,75	2	6,25	50 x 14 x 4,9	27,52	25 x 9	30,79
M 7x1,00	3	6,00	50 x 19 x 4,9	21,88*	25 x 9	24,30*
M 7x1,25	3	5,75	50 x 19 x 4,9	95,16	25 x 9	123,99
M 8x0,50	2	7,50	50 x 16 x 4,9	32,33	25 x 9	30,79
M 8x0,75	2	7,25	50 x 16 x 4,9	27,91	25 x 9	26,48
M 8x1,00	2	7,00	56 x 18 x 4,9	20,64*	25 x 9	26,48*
M 8x1,25	3	6,80	56 x 22 x 4,9	18,15*	25 x 9	18,77*
M 8x1,50	3	6,50	56 x 22 x 4,9	92,57	25 x 9	110,88
M 9x1,00	2	8,00	63 x 18 x 5,5	30,57	25 x 9	37,34
M 9x1,25	3	7,80	63 x 22 x 5,5	24,63*	25 x 9	27,73*
M 10x0,50	2	9,50	63 x 18 x 5,5	49,58	30 x 10	89,53
M 10x0,75	2	9,25	63 x 18 x 5,5	43,04	30 x 11	37,35
M 10x1,00	2	9,00	63 x 18 x 5,5	24,28	38 x 10	30,79
M 10x1,25	2	8,80	70 x 24 x 5,5	22,61	38 x 10	30,80
M 10x1,50	3	8,50	70 x 24 x 5,5	23,37*	38 x 10	21,49*
M 11x0,75	2	10,25	63 x 18 x 6,2	78,14	30 x 11	122,83
M 11x1,00	2	10,00	63 x 18 x 6,2	39,80	30 x 11	41,92
M 11x1,25	2	9,75	63 x 20 x 6,2	39,80	30 x 11	43,00
M 11x1,50	3	9,50	70 x 24 x 6,2	49,99	38 x 10	31,67
M 12x0,75	2	11,25	70 x 20 x 7,0	39,53	38 x 10	43,58
M 12x1,00	2	11,00	70 x 20 x 7,0	39,78	38 x 10	37,34
M 12x1,25	2	10,75	70 x 20 x 7,0	39,65	38 x 10	37,34
M 12x1,50	2	10,50	70 x 20 x 7,0	36,58*	38 x 10	36,36*
M 12x1,75	3	10,20	75 x 29 x 7,0	29,45*	38 x 14	31,09*
M 13x0,75	2	12,25	70 x 20 x 9,0	80,30	38 x 10	115,87
M 13x1,00	2	12,00	70 x 20 x 9,0	62,12	38 x 10	47,81
M 13x1,25	2	11,75	70 x 20 x 9,0	64,10	38 x 10	79,42
M 13x1,50	2	11,50	70 x 20 x 9,0	61,08	38 x 10	47,78
M 13x1,75	3	11,25	70 x 20 x 9,0	79,30	38 x 14	72,07
M 14x0,75	2	13,25	70 x 20 x 9,0	62,39	38 x 10	49,06
M 14x1,00	2	13,00	70 x 20 x 9,0	61,78	38 x 10	47,21
M 14x1,25	2	12,80	70 x 20 x 9,0	46,09*	38 x 10	42,03*
M 14x1,50	2	12,50	70 x 20 x 9,0	39,49	38 x 10	42,03
M 14x1,75	2	12,25	70 x 20 x 9,0	81,08	38 x 14	178,54
M 14x2,00	3	12,00	80 x 30 x 9,0	37,91*	38 x 14	33,91*
M 15x1,00	2	14,00	70 x 20 x 9,0	66,98	45 x 14	63,58
M 15x1,25	2	13,75	70 x 20 x 9,0	95,64	45 x 14	108,51
M 15x1,50	2	13,50	70 x 20 x 9,0	67,64	45 x 14	61,13
M 15x2,00	3	13,00	80 x 30 x 9,0	97,97	45 x 14	93,93
M 16x1,00	2	15,00	70 x 20 x 9,0	67,38	45 x 14	61,12
M 16x1,25	2	14,75	70 x 20 x 9,0	67,79	45 x 14	65,32
M 16x1,50	2	14,50	70 x 20 x 9,0	48,55*	45 x 14	49,84*
M 16x2,00	3	14,00	80 x 32 x 9,0	45,47*	45 x 18	39,78*
M 17x1,00	2	16,00	70 x 20 x 9,0	145,17	45 x 14	111,18
M 17x1,25	2	15,75	70 x 20 x 9,0	145,17	45 x 14	115,64
M 17x1,50	2	15,50	70 x 20 x 9,0	145,17	45 x 14	111,18
M 18x1,00	2	17,00	80 x 22 x 11,0	72,71	45 x 14	57,34
M 18x1,25	2	16,75	80 x 22 x 11,0	75,48	45 x 14	61,28

* Consultare il prezzo delle serie di maschi e filiere a sinistra disponibili a Pag.188

* Sovrapprezzo per le filiere regolabili pari al 20% del prezzo.

SERIE DI MASCHI E FILIERE PER FILETTARE A MANO HSS

DIN 13
60°

Ref. M0

HSS

DIN
352

DIN
2181

TOL
6H

Ref. C5

HSS

DIN
223

TOL
6g

M0						C5						M0						C5					
U.ità	Ø	L1 x L2 x L3 mm	€	Ø x L3 mm	€	U.ità	Ø	L1 x L2 x L3 mm	€	Ø x L3 mm	€	U.ità	Ø	L1 x L2 x L3 mm	€	Ø x L3 mm	€	U.ità	Ø	L1 x L2 x L3 mm	€	Ø x L3 mm	€
M 18x1,50	2	16,50	80 x 22 x 11,0	49,53	45 x 14	51,83	M 33x3,50	3	29,5	125 x 50 x 20,0	306,58*	65 x 25	112,79*										
M 18x2,00	2	16,00	80 x 22 x 11,0	73,38*	45 x 14	58,89*	M 34x1,50	2	32,5	100 x 25 x 22,0	317,79	65 x 18	138,48										
M 18x2,50	3	15,50	95 x 40 x 11,0	60,41*	45 x 18	45,18*	M 34x2,00	2	32,0	100 x 25 x 22,0	349,08	65 x 18	138,50										
M 19x1,00	2	18,00	80 x 22 x 11,0	210,68	45 x 14	140,56	M 35x1,50	2	33,5	100 x 25 x 22,0	305,64	65 x 18	134,64										
M 19x1,25	2	17,75	80 x 22 x 11,0	210,68	45 x 14	165,33	M 35x2,00	2	33,0	100 x 25 x 22,0	384,93	65 x 18	272,29										
M 19x1,50	2	17,50	80 x 22 x 11,0	210,68	45 x 14	140,56	M 36x1,50	2	34,5	100 x 25 x 22,0	340,63	65 x 18	134,65										
M 19x2,00	2	17,00	80 x 22 x 11,0	234,60	45 x 14	167,00	M 36x2,00	2	34,0	125 x 33 x 22,0	381,65	65 x 18	134,65										
M 20x1,00	2	19,00	80 x 22 x 12,0	94,49	45 x 14	57,34	M 36x3,00	2	33,0	125 x 33 x 22,0	415,42*	65 x 25	134,64*										
M 20x1,25	2	18,75	80 x 22 x 12,0	90,25	45 x 14	58,93	M 36x4,00	3	32,0	150 x 53 x 22,0	380,32*	65 x 25	112,82*										
M 20x1,50	2	18,50	80 x 22 x 12,0	53,66	45 x 14	50,43	M 38x1,50	2	36,5	100 x 25 x 22,0	393,69	75 x 20	217,08										
M 20x2,00	2	18,00	80 x 22 x 12,0	94,32*	45 x 14	57,34*	M 38x2,00	2	36,0	125 x 25 x 22,0	477,58	75 x 20	169,28										
M 20x2,50	3	17,50	95 x 40 x 12,0	66,68*	45 x 18	43,94*	M 39x1,50	2	37,5	110 x 25 x 24,0	472,80	75 x 20	210,93										
M 21x1,00	2	20,00	80 x 22 x 12,0	264,84	45 x 14	70,70	M 39x2,00	2	37,0	125 x 23 x 24,0	472,80	75 x 20	210,91										
M 21x1,25	2	19,75	80 x 22 x 12,0	264,84	45 x 14	179,09	M 39x3,00	2	36,0	125 x 33 x 24,0	467,47*	75 x 30	210,93*										
M 21x1,50	2	19,50	80 x 22 x 12,0	104,24	45 x 14	89,70	M 39x4,00	3	35,0	150 x 53 x 24,0	430,40*	75 x 30	174,84*										
M 22x1,00	2	21,00	80 x 22 x 14,5	94,12	55 x 16	92,53	M 40x1,50	2	38,5	110 x 25 x 24,0	462,33	75 x 20	240,15										
M 22x1,25	2	20,75	80 x 22 x 14,5	107,71	55 x 16	91,48	M 40x2,00	2	38,0	125 x 33 x 24,0	461,97	75 x 20	245,99										
M 22x1,50	2	20,50	80 x 22 x 14,5	78,31	55 x 16	79,36	M 40x3,00	2	37,0	125 x 33 x 24,0	460,26	75 x 30	210,91										
M 22x2,00	2	20,00	80 x 22 x 14,5	91,51*	55 x 16	88,97*	M 42x1,50	2	40,5	110 x 25 x 24,0	461,69	75 x 20	210,93										
M 22x2,50	3	19,50	100 x 40 x 14,5	93,25*	55 x 22	77,31*	M 42x2,00	2	40,0	125 x 33 x 24,0	493,25	75 x 20	164,47										
M 23x1,00	2	22,00	80 x 22 x 14,5	272,26	55 x 16	186,25	M 42x3,00	2	39,0	125 x 33 x 24,0	488,60	75 x 30	210,93										
M 23x1,50	2	21,50	80 x 22 x 14,5	122,58	55 x 16	95,14	M 42x4,50	3	37,5	150 x 53 x 24,0	604,05	75 x 30	174,85										
M 24x1,00	2	23,00	90 x 22 x 14,5	121,01	55 x 16	92,53	M 45x1,50	2	43,5	110 x 25 x 29,0	533,81	90 x 22	337,00										
M 24x1,25	2	22,75	90 x 22 x 14,5	122,14	55 x 16	83,92	M 45x2,00	2	43,0	125 x 33 x 29,0	543,67	90 x 22	334,58										
M 24x1,50	2	22,50	90 x 22 x 14,5	92,73	55 x 16	79,36	M 45x3,00	2	42,0	125 x 33 x 29,0	543,67	90 x 36	334,55										
M 24x2,00	2	22,00	90 x 22 x 14,5	124,70*	55 x 16	92,53*	M 45x4,50	3	40,5	160 x 60 x 29,0	697,33	90 x 36	301,67										
M 24x3,00	3	21,00	110 x 50 x 14,5	108,05*	55 x 22	80,39*	M 48x1,50	2	46,5	140 x 33 x 29,0	601,58	90 x 22	334,58										
M 25x1,00	2	24,00	90 x 22 x 14,5	181,64	55 x 16	122,23	M 48x2,00	2	46,0	140 x 33 x 29,0	657,52	90 x 22	334,57										
M 25x1,25	2	23,75	90 x 22 x 14,5	319,13	55 x 16	219,99	M 48x3,00	2	45,0	140 x 33 x 29,0	658,83	90 x 36	334,55										
M 25x1,50	2	23,50	90 x 22 x 14,5	188,27	55 x 16	118,83	M 48x5,00	3	43,0	180 x 65 x 29,0	797,62	90 x 36	290,08										
M 25x2,00	2	23,00	90 x 22 x 14,5	377,64	55 x 16	139,86	M 50x1,50	2	48,5	140 x 33 x 29,0	651,77	90 x 22	337,00										
M 26x1,00	2	25,00	90 x 22 x 14,5	182,96	55 x 16	112,14	M 50x3,00	2	57,0	140 x 33 x 29,0	700,44	90 x 22	334,57										
M 26x1,50	2	24,50	90 x 22 x 14,5	177,45	55 x 16	99,32	M 52x1,50	2	50,5	140 x 33 x 32,0	685,10	90 x 22	334,55										
M 26x2,00	2	24,00	90 x 22 x 14,5	183,78	55 x 16	112,14	M 52x2,00	2	50,0	140 x 33 x 32,0	844,54	90 x 22	334,57										
M 27x1,00	2	26,00	90 x 22 x 16,0	183,80	65 x 18	134,64	M 52x3,00	2	49,0	140 x 33 x 32,0	852,11	90 x 36	334,57										
M 27x1,50	2	25,50	90 x 22 x 16,0	187,20	65 x 18	149,61	M 52x5,00	3	47,0	180 x 65 x 32,0	1.010,51	90 x 36	301,68										
M 27x2,00	2	25,00	90 x 22 x 16,0	223,37*	65 x 18	134,65*	M 56x4,00	2	52,0	180 x 47 x 32,0	1.001,01	105 x 36											
M 27x3,00	3	24,00	110 x 50 x 16,0	140,65*	65 x 25	95,23*	M 56x5,50	3	50,5	200 x 85 x 35,0	1.336,17	105 x 36											
M 28x1,00	2	27,00	90 x 22 x 16,0	220,98	65 x 18	108,00	M 60x5,50	3	54,5	200 x 85 x 35,0	1.737,88	105 x 36											
M 28x1,50	2	26,50	90 x 22 x 16,0	197,15	65 x 18	134,65	M 64x4,00	2	60,0	180 x 50 x 35,0	1.634,17	120 x 36											
M 28x2,00	2	26,00	90 x 22 x 16,0	219,71	65 x 18	104,99	M 64x6,00	3	58,0	220 x 90 x 39,0	2.017,93	120 x 36											
M 30x1,00	2	29,00	90 x 22 x 18,0	220,99	65 x 18	134,65	M 68x6,00	3	62,0	220 x 90 x 39,0	2.461,87	120 x 36											
M 30x1,50	2	28,50	90 x 22 x 18,0	210,10	65 x 18	149,60	M 72x6,00	3	66,0	235 x 90 x 39,0	2.812,95	120 x 36											
M 30x2,00	2	28,00	90 x 22 x 18,0	242,21	65 x 18	134,65	FILIERE CON MISURA ESTERNA IN POLLICI																
M 30x3,00	2	27,00	125 x 56 x 18,0	236,78*	65 x 25	107,99*																	
M 30x3,50	3	26,50	125 x 50 x 18,0	178,23*	65 x 25	112,82*																	
M 32x1,00	2	31,00	90 x 22 x 18,0	323,15	65 x 18	203,60																	
M 32x1,50	2	30,50	90 x 22 x 18,0	259,34	65 x 18	134,64																	
M 32x2,00	2	30,00	90 x 22 x 18,0	323,69	65 x 18	108,00																	
M 33x1,00	2	32,00	100 x 25 x 20,0	491,15	65 x 18	219,99																	
M 33x1,50	2	31,50	100 x 25 x 20,0	267,53	65 x 18	138,50																	
M 33x2,00	2	31,00	100 x 25 x 20,0	360,10	65 x 18	138,50																	
M 33x3,00	2	30,00	125 x 56 x 20,0	417,44*	65 x 25	127,05*																	
												C5											
												Ø x L3 mm	€			Ø x L3 mm	€						
												M 3x0,50	25,4 x 9,5	20,55	M 8x1,25	38,1 x 12,7	27,95						
												M 4x0,70	25,4 x 9,5	20,55	M 10x1,50	25,4 x 9,5	25,83						
												M 5x0,80	25,4 x 9,5	20,39	M 10x1,50	38,1 x 12,7	34,66						
												M 6x1,00	25,4 x 9,5	20,55	M 12x1,75	25,4 x 9,5	25,58						
												M 8x1,25	25,4 x 9,5	20,57	M 12x1,75	38,1 x 12,7	34,96						

* Consultare il prezzo delle serie di maschi e filiere a sinistra disponibili a Pag.188

* Sovrapprezzo per le filiere regolabili pari al 20% del prezzo.

SERIE DI MASCHI E FILIERE PER FILETTARE A MANO HSS

UNC

Ref. M0

Ref. C5

HSS

DIN 351

TOL 2B

HSS

DIN 223

TOL 2a

UNF

Ref. M0

Ref. C5

HSS

DIN 2181

TOL 2B

HSS

DIN 223

TOL 2a



Icona	Unità	D1 mm	L1	L2 x L3	M0		C5	
					€	Ø x L3 mm	€	
UNC n°1-64h.	3	1,85	1,50	36x8x2,1	112,70	16x5		
UNC n°2-56h.	3	2,18	1,80	36x9x2,1	79,64	16x5		
UNC n°3-48h.	3	2,51	2,10	40x9x2,1	79,64	16x5		
UNC n°4-40h.	3	2,84	2,25	40x11x2,7	58,53	20x5	37,78	
UNC n°5-40h.	3	3,17	2,60	40x11x2,7	58,76	20x5	37,78	
UNC n°6-32h.	3	3,50	2,75	45x13x3,0	58,76	20x7	37,78	
UNC n°8-32h.	3	4,17	3,50	45x13x3,4	58,76	20x7	37,78	
UNC n°10-24h.	3	4,83	3,90	50x16x4,9	58,76	20x7	37,78	
UNC n°12-24h.	3	5,49	4,50	50x19x4,9	58,76	20x7	37,78	
UNC 1/4-20h.	3	6,35	5,10	50x19x4,9	31,65*	20x7	31,57*	
UNC 5/16-18h.	3	7,94	6,60	56x22x4,9	34,84*	25x9	34,96*	
UNC 3/8-16h.	3	9,52	8,00	70x24x5,5	39,02*	30x11	36,89*	
UNC 7/16-14h.	3	11,11	9,40	70x24x6,2	48,39	38x14	42,53	
UNC 1/2-13h.	3	12,70	10,75	75x29x7,0	64,97*	38x14	47,35*	
UNC 9/16-12h.	3	14,28	12,20	80x30x9,0	76,69	38x14	52,28	
UNC 5/8-11h.	3	15,87	13,50	80x32x9,0	86,89*	45x18	52,10*	
UNC 3/4-10h.	3	19,05	16,50	95x40x11,0	115,29*	45x18	61,14*	
UNC 7/8-9h.	3	22,22	19,50	100x40x14,5	141,93	55x22	90,70	
UNC 1"-8h.	3	25,40	22,25	110x50x14,5	171,13*	55x22	90,70*	
UNC 1.1/8-7h.	3	28,57	25,00	125x56x18,0	350,90	65x25	147,01	
UNC 1.1/4-7h.	3	31,75	28,00	125x56x18,0	415,70	65x25	147,01	
UNC 1.3/8-6h.	3	34,92	30,75	150x63x22,0	642,71	65x25	147,01	
UNC 1.1/2-6h.	3	38,10	34,00	150x63x24,0	627,26	75x30	147,02	
UNC 2"-4,5h.	3	50,80	45,00	180x75x32,0	1.285,70	90x36		

Icona	Unità	D1 mm	L1	L2 x L3	M0		C5	
					€	Ø x L3 mm	€	
UNF n°2-64h.	2	2,18	1,85	36x8x2,1	70,04			
UNF n°3-56h.	2	2,51	2,15	40x9x2,1	59,55			
UNF n°4-48h.	2	2,84	2,35	40x9x2,7	35,80	20x5	37,78	
UNF n°5-44h.	2	3,17	2,70	45x10x2,7	35,80	20x5	37,78	
UNF n°6-40h.	2	3,50	2,95	45x16x3,0	35,45	20x5	37,78	
UNF n°8-36h.	2	4,17	3,50	50x12x3,4	35,45	20x7	37,78	
UNF n°10-32h.	2	4,83	4,10	50x12x4,9	35,45	20x7	37,78	
UNF n°12-28h.	2	5,49	4,60	50x12x4,9	35,35	20x7	37,78	
UNF 1/4-28h.	2	6,35	5,50	50x14x4,9	21,65*	25x9	31,57*	
UNF 5/16-24h.	2	7,94	6,90	56x22x4,9	21,47*	25x9	34,98*	
UNF 3/8-24h.	2	9,52	8,50	63x20x5,5	31,09*	38x10	36,31*	
UNF 7/16-20h.	2	11,11	9,90	63x20x6,2	36,04	38x10	42,54	
UNF 1/2-20h.	2	12,70	11,50	70x22x7,0	38,47*	38x10	47,35*	
UNF 9/16-18h.	2	14,29	12,90	70x22x9,0	47,35	38x10	51,11	
UNF 5/8-18h.	2	15,87	14,50	70x22x9,0	53,95*	45x14	52,10*	
UNF 3/4-16h.	2	19,05	17,50	80x22x11,0	70,06*	45x14	61,14*	
UNF 7/8-14h.	2	22,22	20,40	80x22x14,5	93,15*	55x16	90,70*	
UNF 1"-12h.	2	25,40	23,25	90x22x16,0	137,93	55x16	90,70	
UNF 1"-14h.	2	25,40	23,60	90x22x14,5	155,90*	55x16	118,33*	
UNF 1.1/8-12h.	2	28,57	26,50	90x22x18,0	166,34	65x18	147,02	
UNF 1.1/4-12h.	2	31,75	29,50	90x22x20,0	316,78	65x18	147,01	
UNF 1.3/8-12h.	2	34,92	32,80	125x35x22,0	240,29	65x18	147,01	
UNF 1.1/2-12h.	2	38,10	36,00	125x40x22,0	398,42	75x20	230,95	
UNF 2"-12h.	2	50,80	48,38	140x40x29,0	1.251,91	90x22		

SERIE DI MASCHI E FILIERE PER FILETTARE A MANO HSS



U	D1	L1 x L2 x L3	M0		C5		MOT		C5T		MOX		CSX	
			HSS	€	HSS	€	HSS	€	HSS	€	HSSCo	€	HSSCo	€
G 1/8-28h.	2	9,73	8,80	63 x 20 x 5,5	32,51*	38 x 10	43,96*	G 1/8-28 h.	2	69,35	67,97	79,66	52,81	
G 1/4-19h.	2	13,16	11,80	70 x 22 x 9,0	34,72*	38 x 10	41,19*	G 1/4-19 h.	2	93,91	73,35	106,58	55,23	
G 3/8-19h.	2	16,66	15,25	70 x 22 x 9,0	50,86*	45 x 14	55,78*	G 3/8-19 h.	2	135,10	79,13	156,11	67,34	
G 1/2-14h.	2	20,95	19,00	80 x 22 x 12,0	79,86*	45 x 14	55,78*	G 1/2-14 h.	2	226,56	89,57	250,63	71,71	
G 5/8-14h.	2	22,91	21,00	80 x 22 x 14,5	94,84*	55 x 16	88,47*							
G 3/4-14h.	2	26,44	24,50	90 x 22 x 16,0	116,64*	55 x 16	88,46*	G 3/4-14 h.	2	262,46	145,92	317,64	107,03	
G 7/8-14h.	2	30,20	28,25	90 x 22 x 18,0	187,34	65 x 18	113,77							
G 1"-11h.	2	33,25	30,75	100 x 25 x 20,0	174,83*	65 x 18	113,76*	G 1" -11 h.	2	413,33	194,92	472,09	138,52	
G 1.1/8-11h.	2	37,90	35,50	125 x 40 x 22,0	352,09	75 x 20	175,74							
G 1.1/4-11h.	2	41,91	39,50	125 x 40 x 24,0	281,23*	75 x 20	175,75*							
G 1.3/8-11h.	2	44,32	42,00	125 x 40 x 29,0	466,54	90 x 22	261,48							
G 1.1/2-11h.	2	47,80	45,25	140 x 40 x 29,0	413,53	90 x 22	261,48							
G 1.3/4-11h.	2	53,75	51,25	140 x 40 x 32,0	752,84	105 x 22	271,90							
G 2"-11h.	2	59,61	57,00	160 x 40 x 35,0	673,77	105 x 22	291,99							
G 2.1/4-11h.	2	65,71	63,00	160 x 40 x 39,0	1.585,17	105 x 22								
G 2.1/2-11h.	2	75,18	72,50	160 x 40 x 39,0	1.875,72	120 x 22								
G 2.3/4-11h.	2	81,53	79,00	160 x 40 x 39,0	2.735,55	120 x 22								
G 3"-11h.	2	87,88	85,50	160 x 40 x 39,0	2.847,14	150 x 25								
G 4"-11h.	2	113,03	110,50	180 x 45 x 44,0	4.318,15	180 x 25								



U	D1	L1 x L2 x L3	M0-3B		
UNF n°4-48-3B	2	2,84	2,35	40x9x2,7	55,59
UNF n°5-44-3B	2	3,17	2,70	45x10x2,7	55,59
UNF n°6-40-3B	2	3,50	2,95	45x16x3,0	52,94
UNF n°8-36-3B	2	4,17	3,50	50x12x3,4	52,94
UNF n°10-32-3B	2	4,83	4,10	50x12x4,9	52,94
UNF n°12-28-3B	2	5,49	4,60	50x12x4,9	55,59
UNF 1/4-28-3B	2	6,35	5,50	50x14x4,9	40,55
UNF 5/16-24-3B	2	7,94	6,90	56x22x4,9	43,41
UNF 3/8-24-3B	2	9,52	8,50	63x20x5,5	50,12
UNF 7/16-20-3B	2	11,11	9,90	63x20x6,2	66,52
UNF 1/2-20-3B	2	12,70	11,50	70x22x7,0	68,05

* Consultare il prezzo delle serie di maschi e filiere a sinistra disponibili a Pag.188

Maschi e Filiere
Verde Rosa

SERIE DI MASCHI E FILIERE PER FILETTARE A MANO HSS

BSW

Ref. M0

HSS

DIN 351

TOL Classe 2

Ref. C5

HSS

DIN 223

BSF

Ref. M0

HSS

DIN 5157

TOL ISO 228

Ref. C5

HSS

DIN 223



Icona	U.tà	D1 mm	L1 x L2 x Ø	M0		C5	
				€	Ø x L3 mm	€	Ø x L3 mm
W 1/16-60h.	3	1,59	1,15	32x8x2,1	40,28	16x5	80,92
W 3/32-48h.	3	2,38	1,80	40x9x2,1	43,96	20x5	31,29
W 1/8-40h.	3	3,17	2,55	40x14x2,7	31,58*	25x9	31,57*
W 5/32-32h.	3	3,97	3,10	45x17x3,4	29,99	25x9	31,57
W 3/16-24h.	3	4,76	3,60	50x19x4,9	30,00	25x9	31,57
W 7/32-24h.	3	5,55	4,40	50x19x4,9	29,61	25x9	31,58
W 1/4-20h.	3	6,35	5,10	50x20x4,9	29,88*	25x9	31,57*
W 5/16-18h.	3	7,94	6,50	56x20x4,9	34,76*	25x9	34,98*
W 3/8-16h.	3	9,52	7,90	63x22x5,5	42,96*	38x10	37,78*
W 7/16-14h.	3	11,11	9,25	70x22x6,2	46,13	38x10	42,53
W 1/2-12h.	3	12,70	10,50	75x25x7,0	68,07	38x14	47,36
W 9/16-12h.	3	14,29	12,00	80x26x9,0	72,03	38x14	56,36
W 5/8-11h.	3	15,87	13,40	80x27x9,0	82,83*	45x18	57,21*
W 11/16-11h.	3	17,46	15,25	95x32x11,0	244,10	45x18	57,44
W 3/4-10h.	3	19,05	16,50	95x32x11,0	110,24*	45x18	61,16*
W 7/8-9h.	3	22,22	19,25	100x32x14,5	135,93*	55x22	90,69*
W 1"-8h.	3	25,40	21,75	110x36x14,5	222,97*	55x22	90,69*
W 1.1/8-7h.	3	28,57	24,75	125x40x18,0	281,10	65x25	169,44
W 1.1/4-7h.	3	31,75	27,75	125x40x18,0	312,53	65x25	169,50
W 1.3/8-6h.	3	34,92	30,50	150x50x22,0	428,66	65x25	172,63
W 1.1/2-6h.	3	38,10	33,50	150x50x24,0	481,67	75x30	262,41
W 1.5/8-5h.	3	41,27	46,50	150x56x24,0	866,95	75x30	314,67
W 1.3/4-5h.	3	44,45	39,00	160x58x29,0	874,07	90x36	396,02
W 1.7/8-4,5h.	3	47,62	42,00	180x65x29,0	1.231,54	90x36	433,32
W 2"-4,5h.	3	50,80	44,50	180x65x32,0	1.369,84	90x36	454,14
W 2.1/4-4h.	3	57,15	50,00	200x85x35,0	2.550,32	105x36	
W 2.1/2-4h.	3	63,50	56,50	220x85x39,0	3.102,51	120x36	
W 2.3/4-3,5h.	3	69,85	62,00	250x90x44,0	4.430,01	120x36	
W 3"-3,5h.	3	76,20	68,00	250x90x44,0	5.125,04	140x36	

Icona	U.tà	D1 mm	L1 x L2 x Ø	M0		C5	
				€	Ø x L3 mm	€	Ø x L3 mm
BSF 3/16-32h.	2	4,76	4,0	50x19x4,9	29,71	20x7	31,57
BSF 1/4-26h.	2	6,35	5,2	50x20x4,9	29,49	20x7	31,58
BSF 5/16-22h.	2	7,94	6,6	56x20x4,9	29,60	25x9	34,98
BSF 3/8-20h.	2	9,52	8,1	63x22x5,5	41,73	30x11	40,59
BSF 7/16-18h.	2	11,11	9,5	70x22x6,2	39,54	30x11	42,54
BSF 1/2-16h.	2	12,70	11,0	75x25x7,0	55,79	38x10	57,51
BSF 9/16-16h.	2	14,29	12,5	80x26x9,0	72,16	38x10	63,12
BSF 5/8-14h.	2	15,88	14,0	80x26x9,0	69,45	45x14	84,23
BSF 3/4-12h.	2	19,05	16,5	95x33x11,0	95,54	45x14	84,23
BSF 7/8-11h.	2	22,23	19,5	100x33x14,5	108,96	55x22	105,36
BSF 1"-10h.	2	25,40	22,5	110x40x14,5	145,83	55x22	105,36
BSF 1.1/8-9h.	2	28,57	25,5	110x40x16,0	561,81		
BSF 1.1/4-9h.	2	31,75	28,5	125x46x18,0	641,41		
BSF 1.1/2-8h.	2	38,10	34,5	150x55x22,0	977,54		

BSW

INOX

TiN

Icona	U.tà	L1 x L2 x Ø	M0T		C5T	
			€	Ø x L3 mm	€	Ø x L3 mm
W 3/16-24 h.	3	50 x 19 x 4,90	56,98	25x9	44,98	
W 1/4-20 h.	3	50 x 20 x 4,90	56,39	25x9	46,39	
W 5/16-18 h.	3	56 x 20 x 4,90	58,84	25x9	52,66	
W 3/8-16 h.	3	63 x 22 x 5,50	77,92	38x10	47,27	
W 1/2-12 h.	3	75 x 25 x 7,00	120,94	38x14	81,63	



* Consultare il prezzo delle serie di maschi e filiere a sinistra disponibili a Pag.188

MASCHI E FILIERE PER FILETTARE A MANO HSS

NPTF

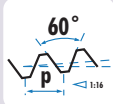

Filettatura AMERICANA
Filettatura conica a tenuta stagna

Ref. M0

HSS

Ref. C5

HSS

DIN
223

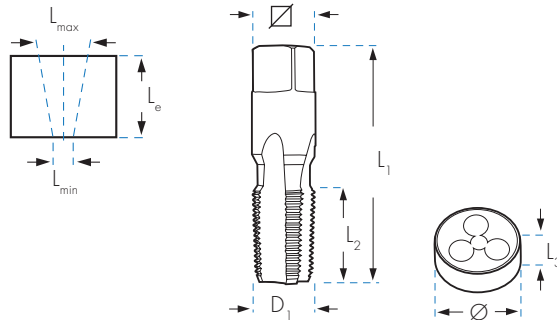

							M0	C5		
		U.tà	D ₁ mm	Ø	L _{min} x L _{max} mm	L _e mm	L ₁ x L ₂ x mm	€	Ø x L ₃ mm	€
NPTF 1/8-27 h.	1		10,22	8,5	8,30 x 8,76	12,0	54 x 19 x 8,0	87,90	38 x 10	191,97
NPTF 1/4-18 h.	1		13,58	11,0	10,70 x 11,40	17,5	62 x 27 x 11,0	123,20	38 x 15	191,97
NPTF 3/8-18 h.	1		17,02	14,5	14,20 x 14,84	17,6	65 x 27 x 13,0	170,09	45 x 14	250,67
NPTF 1/2-14 h.	1		21,21	17,8	17,40 x 18,33	22,8	80 x 35 x 13,0	237,84	45 x 20	250,67
NPTF 3/4-14 h.	1		26,56	23,0	22,80 x 23,68	23,0	83 x 35 x 17,0	363,56	55 x 22	477,73
NPTF 1"-11,5 h.	1		33,19	29,0	28,60 x 29,72	27,4	110 x 38 x 20,0	484,25		

NPT

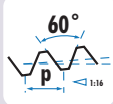

Filettatura AMERICANA
Filettatura conica non a tenuta stagna (Briggs)

Ref. M0

HSS

Ref. C5

HSS

DIN
223

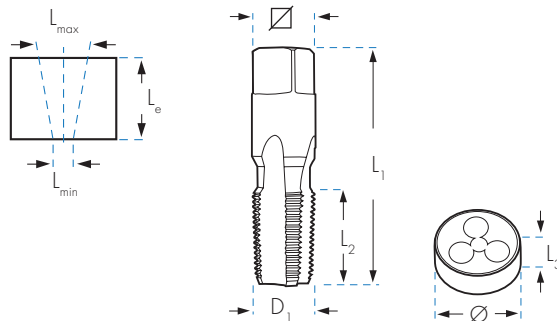

								M0	C5		
		U.tà	D ₁ mm	Ø		L _{min} x L _{max} mm	L _e mm	L ₁ x L ₂ x mm	€	Ø x L ₃ mm	€
NPT 1/16-27 h.	1		7,89	6,20	EMNPT1/16	6,00 x 6,38	12,0	54 x 18 x 6,0	36,79	25 x 9	79,61
NPT 1/8-27 h.	1		10,24	8,50	EMNPT1/8	8,30 x 8,73	12,0	65 x 19 x 5,5	38,63	30 x 11	85,48
NPT 1/4-18 h.	1		13,62	11,00	EMNPT1/4	10,70 x 11,35	17,5	62 x 27 x 11,0	54,20	38 x 14	101,37
NPT 3/8-18 h.	1		17,05	14,50	EMNPT3/8	14,20 x 14,80	17,6	65 x 27 x 13,0	74,79	45 x 18	126,47
NPT 1/2-14 h.	1		21,23	17,80	EMNPT1/2	17,40 x 18,32	22,8	80 x 35 x 13,0	104,57	45 x 18	131,52
NPT 3/4-14 h.	1		26,57	23,00	-	22,80 x 23,66	23,0	83 x 35 x 17,0	159,88	55 x 22	198,96
NPT 1"-11,5 h.	1		33,23	29,00	-	28,60 x 29,69	27,4	95 x 44 x 21,0	178,06	65 x 25	288,19
NPT 1.1/4-11,5 h.	1		41,98	37,50	-	37,40 x 38,45	28,1	125 x 33 x 24,0	291,93	75 x 26	336,87
NPT 1.1/2-11,5 h.	1		48,05	44,00	-	43,40 x 44,52	28,4	140 x 33 x 29,0	443,60	90 x 27	469,97
NPT 2"-11,5 h.	1		60,09	56,00	-	55,50 x 56,56	28,4	160 x 33 x 35,0	692,54	105 x 36	654,33
NPT 2.1/2"-8h.	1		73,03	67,00	-	68,68 x 69,08	28,9	200 x 45 x 39,0	854,35		
NPT 3"-8h.	1		88,90	82,00	-	84,45 x 84,86	30,5	220 x 48 x 39,0	1.200,88		

* Vedi alesatore precedente a pag. 137

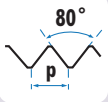
MASCHI E FILIERE PER FILETTARE A MANO HSS
PG

Ref. M0

HSS
**DIN
40430**

Ref. C5

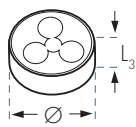
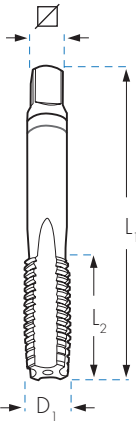
HSS
**DIN
223**

	U.tà	D ₁ mm		L ₁ x L ₂ x	M0		C5	
					€	Ø x L ₃ mm	€	
Pg 7	20h.	1	12,5	11,50	70x20x70	39,36	38x10	72,83
Pg 9	18h.	1	15,2	14,00	70x20x9,0	50,04	38x10	88,69
Pg 11	18h.	1	18,6	17,25	80x22x11,0	69,47	45x14	88,70
Pg 13,5	18h.	1	20,4	19,00	80x22x12,0	76,19	45x14	88,70
Pg 16	18h.	1	22,5	21,25	80x22x14,5	91,50	55x16	102,38
Pg 21	16h.	1	28,3	27,00	90x22x18,0	134,56	65x18	154,38
Pg 29	16h.	1	37,0	35,50	100x25x22,0	267,18	65x18	154,38
Pg 36	16h.	1	47,0	45,50	140x32x29,0	392,63	90x22	439,77
Pg 42	16h.	1	54,0	52,50	140x36x32,0	466,26	105x22	439,77
Pg 48	16h.	1	59,3	58,00	160x36x35,0	588,06	105x22	583,16

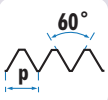
NPSF

 Filettatura AMERICANA
 Filettatura cilindrica a tenuta stagna

Ref. M0

HSS

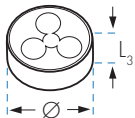
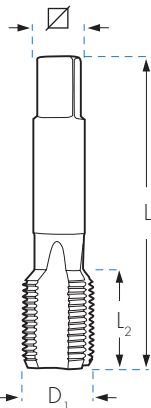
Ref. C5

HSS
**DIN
223**

	U.tà	D ₁ mm		L ₁ x L ₂ x	M0		C5	
					€	Ø x L ₃ mm	€	
NPSF 1/8-27 h.	1	10,05	8,75	63x18x5,5	134,89	38x10	235,02	
NPSF 1/4-18 h.	1	13,35	11,30	70x20x9,0	194,92	38x10	235,02	
NPSF 3/8-18 h.	1	16,78	14,70	70x20x9,0	269,62	45x14	298,96	
NPSF 1/2-14 h.	1	20,87	18,20	80x22x12,0	352,49	45x14	298,96	
NPSF 3/4-14 h.	1	26,23	23,50	90x22x16,0	536,33	55x16	646,22	

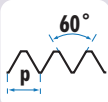
**NPS
(M)**

 Filettatura AMERICANA
 Filettatura cilindrica non a tenuta stagna (Briggs)

Ref. M0

HSS

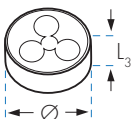
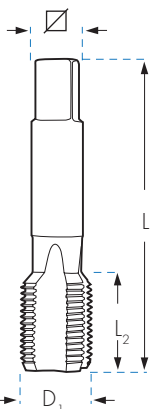
Ref. C5







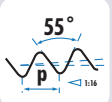

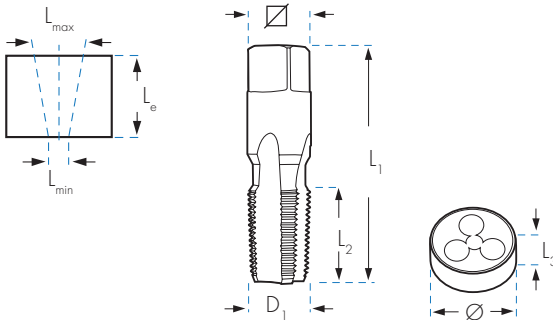











HSS
**DIN
223**

	U.tà	D ₁ mm		L ₁ x L ₂ x	M0		C5	
					€	Ø x L ₃ mm	€	
NPS 1/8-27 h.	1	10,20	8,9	63x18x5,5	111,78	38x10	195,78	
NPS 1/4-18 h.	1	13,60	11,7	70x20x9,0	88,96	38x10	195,78	
NPS 3/8-18 h.	1	17,00	15,0	70x20x9,0	123,03	45x14	249,12	
NPS 1/2-14 h.	1	21,20	18,6	80x22x12,0	160,80	45x14	249,12	
NPS 3/4-14 h.	1	26,55	24,0	90x22x16,0	233,54	55x16	493,50	
NPS 1"-11,5 h.	1	33,20	30,0	100x25x20,0	326,54	65x18	458,42	

SERIE DI MASCHI E FILIERE PER FILETTARE A MANO HSS







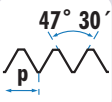

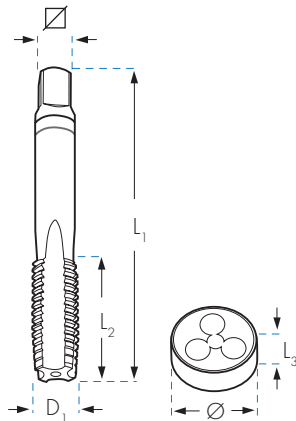









BSPT  Ref. M0 **HSS** **DIN 5157** Ref. C5 **HSS** **DIN 223**



		U.tà	D1 mm		L _{min} x L _{max} mm	L _e mm	L ₁ x L ₂ x  mm	€	Ø x L ₃ mm	€
BSPT 1/8-28 h.		1	9,73		8,00 x 8,50	10,1	65 x 19 x 5,5	39,46	30 x 11	41,56
BSPT 1/4-19 h.		1	13,16		10,70 x 11,35	15,0	70 x 25 x 9,0	48,11	38 x 14	43,35
BSPT 3/8-19 h.		1	16,66		14,15 x 14,25	15,4	70 x 25 x 9,0	66,83	45 x 16	75,78
BSPT 1/2-14 h.		1	20,95		17,60 x 18,50	20,5	80 x 31 x 12,0	93,57	55 x 22	75,78
BSPT 5/8-14 h.		1	22,91		19,50 x 20,40	22,4	80 x 36 x 14,5	174,47	55 x 19	143,95
BSPT 3/4-14 h.		1	26,44		23,00 x 24,00	21,8	85 x 33 x 16,0	156,09	55 x 22	163,39
BSPT 7/8-14 h.		1	30,20		26,65 x 28,75	24,0	100 x 36 x 18,0	334,37	65 x 22	204,42
BSPT 1"-11 h.		1	33,25		29,00 x 30,20	26,0	110 x 38 x 20,0	223,00	65 x 25	180,47

BA  Ref. M0 **HSS** **DIN 352** Ref. C5 **HSS** **DIN 223**



		U.tà	D1 mm		L ₁ x L ₂ x  mm	€	Ø x L ₃ mm	€
BA-0		1,00	3		50 x 18 x 4,9	195,42	20 x 5	94,65
BA-1		0,90	3		50 x 18 x 4,9	195,42	20 x 5	94,65
BA-2		0,81	3		50 x 17 x 4,9	195,42	20 x 5	94,65
BA-3		0,73	3		45 x 14 x 3,4	210,02	20 x 5	94,65
BA-4		0,66	3		45 x 14 x 3,0	210,02	20 x 5	94,65
BA-5		0,59	3		45 x 14 x 3,0	250,93	20 x 5	94,65
BA-6		0,53	3		40 x 12 x 2,7	250,93	20 x 5	94,65
BA-7		0,48	3		40 x 10 x 2,1	275,89	20 x 5	94,65
BA-8		0,43	3		36 x 10 x 2,1	275,89	20 x 5	94,65

SERIE DI MASCHI E FILIERE PER FILETTARE A MANO HSS

UNx8



60°
p

Filettatura AMERICANA

Ref. M0

HSS

DIN
2181

TOL
2B



Ref. C5

HSS

DIN
223

TOL
2a



	U.ità	D1 mm		L1 x L2 x ∇ mm	M0		C5	
					€	Ø x L3 mm	€	
UN 1"1/8-8h.	2	28,57	25,40	138x65x170	375,67	65x25	396,38	
UN 1"1/4-8h.	2	31,75	28,50	146x65x19,5	487,18	65x25	396,38	
UN 1"3/8-8h.	2	34,92	31,75	154x76x21,0	605,93	65x25	379,88	
UN 1"1/2-8h.	2	38,10	35,00	162x76x23,5	693,43	75x30	430,06	
UN 1"5/8-8h.	2	41,27	38,10	170x80x25,0	862,13	75x30	430,06	
UN 1"3/4-8h.	2	44,45	41,25	178x81x27,0	1.074,45	90x36	501,73	
UN 1"7/8-8h.	2	47,62	44,45	186x90x29,0	1.340,43	90x36	593,63	
UN 2"-8h.	2	50,80	47,63	194x90x31,5	1.372,38	90x36	612,69	
UN 2"1/4-8h.	2	57,15	54,00	208x90x36,0				
UN 2"1/2-8h.	2	63,50	60,35	220x100x36,0				
UN 2"3/4-8h.	2	69,85	66,70	234x104x39,0				
UN 3"-8h.	2	76,20	73,05	248x115x49,0				

UNEF



60°
p

Filettatura AMERICANA

Ref. M0

HSS

DIN
2181

TOL
2B

Ref. C5

HSS

DIN
223

TOL
2a



	U.ità	D1 mm		L1 x L2 x ∇ mm	M0		C5	
					€	Ø x L3 mm	€	
UNEF 1/4-32h.	2	6,35	5,55	65x28x4,9	36,72	20x7	74,15	
UNEF 5/16-32h.	2	7,94	7,15	70x30x6,0	41,02	25x9	92,64	
UNEF 3/8-32h.	2	9,52	8,70	75x33x7,0	46,11	30x11	104,95	
UNEF 7/16-28h.	2	11,11	10,20	81x38x6,0	57,66	30x11	145,79	
UNEF 1/2-28h.	2	12,70	11,80	86x44x7,0	68,71	38x10	154,18	
UNEF 9/16-24h.	2	14,29	13,20	92x44x8,0	65,90	38x10	145,79	
UNEF 5/8-24h.	2	15,87	14,80	93x47x9,0	74,24	45x14	241,54	
UNEF 3/4-20h.	2	19,05	17,80	108x52x11,0	99,16	45x14	241,54	
UNEF 7/8-20h.	2	22,22	20,95	120x58x13,0	134,52	55x16	288,43	
UNEF 1"-20h.	2	25,40	24,20	130x65x15,0	157,31	55x16	283,52	

SERIE DI MASCHI E FILIERE PER FILETTARE A MANO APPLICAZIONI SPECIALI

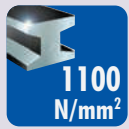

Ref. M0MD

HSSCo
5%

DIN
352

OX

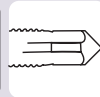

SPECIALE MATERIALI DURI
(≤ 1100 N/mm²=40HRc)

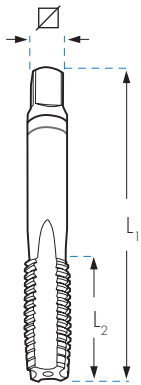

				M0MD
	U.tà		L ₁ x L ₂ x	€
		Ø	mm	
M 3 x 0,50	3	2,50	40 x 11 x 2,7	39,64
M 4 x 0,70	3	3,30	45 x 13 x 3,4	39,64
M 5 x 0,80	3	4,20	50 x 17 x 4,9	40,94
M 6 x 1,00	3	5,00	50 x 19 x 4,9	42,15
M 8 x 1,25	3	6,80	56 x 20 x 4,9	47,90
M 10 x 1,50	3	8,50	70 x 22 x 5,5	61,50
M 12 x 1,75	3	10,20	75 x 24 x 7,0	88,04
M 14 x 2,00	3	12,00	80 x 26 x 9,0	104,22
M 16 x 2,00	3	14,00	80 x 27 x 9,0	138,48
M 18 x 2,50	3	15,50	95 x 30 x 11,0	212,95
M 20 x 2,50	3	17,50	95 x 32 x 12,0	236,44

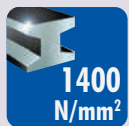

Ref. M0C

HSS
PM

TiAlSiN



SPECIALE MATERIALI MOLTO DURI
(≤ 1400 N/mm²=44HRc)

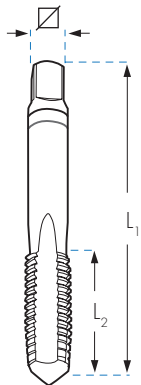

				M0C
	U.tà		L ₁ x L ₂ x	€
		Ø	mm	
M 3 x 0,50	3	2,50	40 x 11 x 2,7	98,73
M 4 x 0,70	3	3,30	45 x 13 x 3,4	106,52
M 5 x 0,80	3	4,20	50 x 17 x 4,9	107,86
M 6 x 1,00	3	5,00	50 x 19 x 4,9	107,86
M 8 x 1,25	3	6,80	56 x 20 x 4,9	121,57
M 10 x 1,50	3	8,50	70 x 22 x 5,5	150,27
M 12 x 1,75	3	10,20	75 x 24 x 7,0	182,68
M 14 x 2,00	3	12,00	80 x 26 x 9,0	224,14
M 16 x 2,00	3	14,00	80 x 27 x 9,0	268,56
M 18 x 2,50	3	15,50	95 x 30 x 11,0	372,35
M 20 x 2,50	3	17,50	95 x 32 x 12,0	409,80

Al

Ref. M0AL

HSS

BRILLANTE

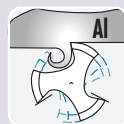

SPECIALE ALLUMINIO

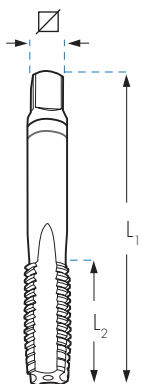

				M0AL
	U.tà		L ₁ x L ₂ x	€
		Ø	mm	
M 3 x 0,50	3	2,50	40 x 11 x 2,7	30,87
M 4 x 0,70	3	3,30	45 x 13 x 3,4	29,97
M 5 x 0,80	3	4,20	50 x 17 x 4,9	31,76
M 6 x 1,00	3	5,00	50 x 19 x 4,9	31,76
M 8 x 1,25	3	6,80	56 x 20 x 4,9	38,98
M 10 x 1,50	3	8,50	70 x 22 x 5,5	47,60
M 12 x 1,75	3	10,20	75 x 24 x 7,0	67,01
M 14 x 2,00	3	12,00	80 x 26 x 9,0	77,01
M 16 x 2,00	3	14,00	80 x 27 x 9,0	109,31
M 18 x 2,50	3	15,50	95 x 30 x 11,0	144,86
M 20 x 2,50	3	17,50	95 x 32 x 12,0	163,30

SERIE DI MASCHI E FILIERE PER FILETTARE A MANO INOX

M

INOX

Ref. MOT
Ref. MOXDIN
352TOL
6H

TiN

Ref. CST
Ref. CSXDIN
223TOL
6g

OX

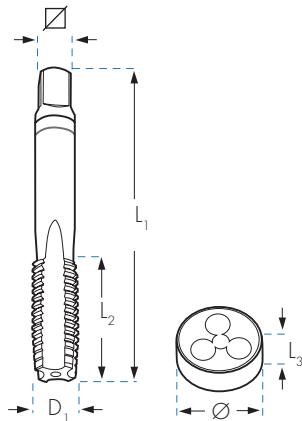

	Uità	L ₁ x L ₂ x ∇ mm	MOT	CST	MOX	CSX	Ø x L ₃ mm
			HSS TiN €	HSS TiN €	HSSCo OX €	HSSCo OX €	
M 3 x 0,50	3	40 x 11 x 2,70	28,91	26,13	29,81	28,52	20 x 5
M 4 x 0,70	3	45 x 13 x 3,40	25,31	60,74	29,81	28,52	20 x 5
M 5 x 0,80	3	50 x 16 x 4,90	27,78	27,34	30,24	27,22	20 x 7
M 6 x 1,00	3	50 x 19 x 4,90	27,78	27,34	30,17	27,19	20 x 7
M 8 x 1,00	2	50 x 19 x 4,90	29,73				
M 8 x 1,25	3	56 x 22 x 4,90	36,72	28,03	34,64	35,44	25 x 9
M 10 x 1,00	2	63 x 18 x 5,50	34,30				
M 10 x 1,50	3	70 x 24 x 5,50	42,99	35,15	46,33	47,41	30 x 11
M 12 x 1,50	2	70 x 20 x 7,00	43,66				
M 12 x 1,75	3	75 x 29 x 7,00	46,28	50,76	60,48	70,16	38 x 14
M 14 x 1,50	2	70 x 20 x 9,00	50,77				
M 14 x 2,00	3	80 x 30 x 9,00	68,14	56,20	76,27	70,16	38 x 14
M 16 x 2,00	3	80 x 32 x 9,00	74,36	71,49	93,05	101,50	45 x 18
M 18 x 2,50	3	95 x 40 x 11,00	96,04		121,87		
M 20 x 2,50	3	95 x 40 x 12,00	102,86		137,19		
M 22 x 2,50	3	100 x 40 x 14,50	130,10				
M 24 x 3,00	3	110 x 50 x 14,50	169,21				

M

FILIERE ESAGONALI HSS PER FILETTARE A MANO

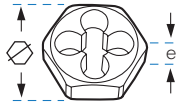

M HSS DIN 382

		C5HM	
		$\phi \times e$	€
M 3 x 0,35		18 x 5	40,06
M 3 x 0,50		19 x 5	22,56
M 3,5 x 0,60		18 x 5	40,06
M 4 x 0,50		18 x 5	40,06
M 4 x 0,70		19 x 5	21,15
M 5 x 0,50		18 x 5	40,06
M 5 x 0,75		18 x 5	40,06
M 5 x 0,80		19 x 7	21,15
M 6 x 0,75		18 x 7	43,93
M 6 x 1,00		19 x 7	22,56
M 7 x 0,75		21 x 9	42,57
M 7 x 1,00		21 x 9	23,91
M 8 x 0,75		21 x 9	46,46
M 8 x 1,00		21 x 9	46,46
M 8 x 1,25		22 x 9	23,91
M 9 x 0,75		21 x 9	48,18
M 9 x 1,00		21 x 9	48,18
M 9 x 1,25		22 x 9	43,38
M 10 x 1,00		27 x 11	46,45
M 10 x 1,25		27 x 11	46,45
M 10 x 1,50		27 x 11	27,51
M 11 x 1,00		27 x 11	72,26
M 11 x 1,50		27 x 11	72,26
M 12 x 1,25		36 x 10	62,15
M 12 x 1,50		36 x 10	62,15
M 12 x 1,75		36 x 10	40,09
M 14 x 1,25		36 x 14	69,46
M 14 x 1,50		36 x 10	69,46
M 14 x 2,00		36 x 10	36,08
M 15 x 1,00		36 x 14	95,24
M 15 x 1,50		41 x 14	95,24
M 16 x 1,00		41 x 14	84,08
M 16 x 1,50		41 x 14	84,08

		C5HM	
		$\phi \times e$	€
M 16 x 2,00		41 x 18	54,45
M 18 x 1,00		41 x 14	95,24
M 18 x 1,50		41 x 14	88,47
M 18 x 2,50		41 x 18	49,01
M 20 x 1,00		41 x 14	95,24
M 20 x 1,50		41 x 14	88,47
M 20 x 2,00		41 x 18	95,24
M 20 x 2,50		41 x 18	54,45
M 22 x 1,00		50 x 16	139,15
M 22 x 1,50		50 x 16	125,28
M 22 x 2,00		50 x 16	139,15
M 22 x 2,50		50 x 16	91,00
M 24 x 1,00		50 x 16	224,54
M 24 x 1,50		50 x 16	125,27
M 24 x 2,00		50 x 16	125,27
M 24 x 3,00		50 x 22	109,95
M 27 x 1,50		60 x 18	188,14
M 27 x 2,00		60 x 18	188,14
M 27 x 3,00		60 x 25	162,05
M 30 x 1,00		60 x 18	188,14
M 30 x 1,50		60 x 18	188,14
M 30 x 2,00		60 x 18	185,44
M 30 x 3,00		60 x 18	188,14
M 30 x 3,50		60 x 25	162,05
M 33 x 1,50		60 x 18	210,66
M 33 x 2,00		60 x 18	210,66
M 33 x 3,50		60 x 25	180,79
M 35 x 1,50		60 x 18	200,81
M 36 x 1,50		60 x 18	200,81
M 36 x 2,00		60 x 18	200,81
M 36 x 3,00		60 x 18	200,81
M 36 x 4,00		60 x 25	167,34

BSW HSS DIN 382

		C5HW	
		$\phi \times e$	€
BSW 1/8 x 40h.		19 x 5	46,32
BSW 3/16 x 24h.		19 x 7	46,32
BSW 1/4 x 20h.		19 x 7	46,32
BSW 5/16 x 18h.		22 x 9	48,64
BSW 3/8 x 16h.		27 x 11	57,90
BSW 7/16 x 14h.		27 x 11	57,90
BSW 1/2 x 12h.		36 x 14	69,50

		C5HW	
		$\phi \times e$	€
BSW 9/16 x 12h.		36 x 14	69,50
BSW 5/8 x 11h.		41 x 18	102,72
BSW 3/4 x 10h.		41 x 18	102,72
BSW 7/8 x 9h.		50 x 22	150,53
BSW 1" x 8h.		50 x 22	150,53
BSW 1.1/8 x 7h.		60 x 25	259,48

BSP (GAS) HSS DIN 382

		C5HG	
		$\phi \times e$	€
G 1/8 x 28h.		27 x 11	81,55
G 1/4 x 19h.		36 x 10	81,55
G 3/8 x 19h.		41 x 14	101,97
G 1/2 x 14h.		41 x 14	101,97
G 5/8 x 14h.		50 x 16	240,09
G 3/4 x 14h.		50 x 16	240,09
G 7/8 x 14h.		60 x 18	242,24
G 1" x 11h.		60 x 18	242,24
G1.1/4 x 11h.		70 x 20	322,98
G1.1/2 x 11h.		85 x 22	544,89
G 2" x 11h.		100 x 22	819,92

UNC HSS DIN 382

		C5HNC	
		$\phi \times e$	€
UNC 1/4-20h		18 x 7	33,77
UNC 5/16-18h		21 x 9	42,03
UNC 3/8-16h		27 x 11	50,72
UNC 7/16-14h		27 x 11	74,86
UNC 1/2-13h		36 x 14	75,13
UNC 9/16-12h		36 x 14	89,77
UNC 5/8-11h		41 x 18	69,56
UNC 3/4-10h		41 x 18	110,66
UNC 7/8-9h		50 x 22	157,04
UNC 1"-8h		50 x 22	157,04
UNC 1.1/8-7h		60 x 25	207,62
UNC 1.1/4-7h		60 x 25	207,62

UNF HSS DIN 382

		C5HNF	
		$\phi \times e$	€
UNF 1/4-28h.		18 x 7	35,80
UNF 5/16-24h.		21 x 9	44,75
UNF 3/8-24h.		27 x 11	53,83
UNF 7/16-20h.		27 x 11	79,33
UNF 1/2-20h.		36 x 10	80,55
UNF 9/16-18h.		36 x 10	89,77
UNF 5/8-18h.		41 x 14	112,01
UNF 3/4-16h.		41 x 14	117,30
UNF 7/8-14h.		50 x 16	148,36
UNF 1"-12h.		50 x 16	155,54
UNS 1"-14h.		50 x 16	155,54
UNF 1.1/8-12h.		60 x 18	207,62
UNF 1.1/4-12h.		60 x 18	207,62

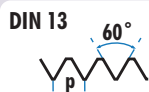
SERIE DI MASCHI E FILIERE PER FILETTARE A MANO, A SINISTRA

Ref. MOI

HSS

DIN
352DIN
2181TOL
6H

Ref. CSI

HSS

DIN
223TOL
6g

Per materiali fino a 38 HRC.

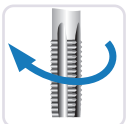

A SINISTRA

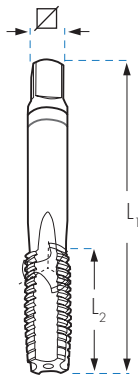

	U.tà	D1 mm	L1 x L2 x mm	MOI €	Ø x L3 mm	CSI €
M 2x0,40	3	1,60	36x9,0x2,1	57,71	16x5	58,13
M 3x0,50	3	2,50	40x11,0x2,7	29,45	25x9	33,09
M 4x0,70	3	3,30	45x13,0x3,4	29,43	25x9	33,09
M 5x0,80	3	4,20	50x16,0x4,9	32,84	25x9	34,13
M 6x1,00	3	5,00	50x19x4,9	33,20	25x9	36,76
M 7x1,00	3	6,00	50x19x4,9	43,76	25x9	48,59
M 8x1,00	2	7,00	56x18x4,9	41,28	25x9	52,96
M 8x1,25	3	6,80	56x22x4,9	36,29	25x9	37,55
M 9x1,25	3	7,80	63x22x5,5	49,27	25x9	55,46
M 10x1,50	3	8,50	70x24x5,5	46,75	38x10	42,97
M 12x1,50	2	10,50	70x20x7,0	73,16	38x10	72,72
M 12x1,75	3	10,20	75x29x7,0	58,91	38x14	62,18
M 14x1,25	2	12,80	70x20x9,0	92,18	38x10	84,06
M 14x2,00	3	12,00	80x30x9,0	75,81	38x14	67,82
M 16x1,50	2	14,50	70x20x9,0	97,10	45x14	99,68
M 16x2,00	3	14,00	80x32x9,0	90,94	45x18	79,56
M 18x2,00	2	16,00	80x22x11,0	146,77	45x14	117,79
M 18x2,50	3	15,50	95x40x11,0	120,83	45x18	90,35
M 20x2,00	2	18,00	80x22x12,0	188,64	45x14	114,67
M 20x2,50	3	17,50	95x40x12,0	133,37	45x18	87,87
M 22x2,00	2	20,00	80x22x14,5	183,02	55x16	177,93
M 22x2,50	3	19,50	100x40x14,5	186,50	55x22	154,61
M 24x2,00	2	22,00	90x22x14,5	249,40	55x16	185,05
M 24x3,00	3	21,00	110x50x14,5	216,09	55x22	160,78
M 27x2,00	2	25,00	90x22x16,0	446,75	65x18	269,30
M 27x3,00	3	24,00	110x50x16,0	281,30	65x25	190,46
M 30x3,00	2	27,00	125x56x18,0	473,57	65x25	215,99
M 30x3,50	3	26,50	125x50x18,0	356,45	65x25	225,63
M 33x2,00	2	31,00	100x25x20,0	720,21	65x18	254,10
M 33x3,50	3	29,50	125x50x20,0	613,17	65x25	225,59
M 36x3,00	2	33,00	125x33x22,0	830,84	65x25	269,28
M 36x4,00	3	32,00	150x53x22,0	760,63	65x25	225,63
M 39x3,00	2	36,00	125x33x24,0	934,94	75x30	421,86
M 39x4,00	3	35,00	150x53x24,0	860,79	75x30	349,67

UNC

	U.tà	D1 mm	L1 x L2 x mm	MOI €	Ø x L3 mm	CSI €	
UNC 1/4-20h.	3	6,35	5,10	50x19x4,9	63,30	20x7	63,13
UNC 5/16-18h.	3	7,94	6,60	56x22x4,9	69,68	25x9	69,92
UNC 3/8-16h.	3	9,52	8,00	70x24x5,5	78,04	30x11	73,78
UNC 1/2-13h.	3	12,70	10,75	75x29x7,0	129,93	38x14	94,70
UNC 5/8-11h.	3	15,87	13,50	80x32x9,0	173,78	45x18	104,20
UNC 3/4-10h.	3	19,05	16,50	95x40x11,0	230,57	45x18	122,28
UNC 1"-8h.	3	25,40	22,25	110x50x14,5	342,25	55x22	181,41

UNF

	U.tà	D1 mm	L1 x L2 x mm	MOI €	Ø x L3 mm	CSI €	
UNF 1/4-28h.	2	6,35	5,50	50x14x4,9	43,29	25x9	63,13
UNF 5/16-24h.	2	7,94	6,90	56x22x4,9	42,93	25x9	69,96
UNF 3/8-24h.	2	9,52	8,50	63x20x5,5	62,18	38x10	72,61
UNF 1/2-20h.	2	12,70	11,50	70x22x7,0	76,93	38x10	94,70
UNF 5/8-18h.	2	15,87	14,50	70x22x9,0	107,91	45x14	104,20
UNF 3/4-16h.	2	19,05	17,50	80x22x11,0	140,11	45x14	122,28
UNS 1"-14h.	2	25,40	23,60	90x22x14,5	311,81	55x16	236,66

**BSP
(GAS)**

	U.tà	D1 mm	L1 x L2 x mm	MOI €	Ø x L3 mm	CSI €	
G 1/8-28h.	2	9,73	8,80	63 x 20 x 5,5	65,02	38x10	87,92
G 1/4-19h.	2	13,16	11,80	70 x 22 x 9,0	69,43	38x10	82,38
G 3/8-19h.	2	16,66	15,25	70 x 22 x 9,0	101,72	45x14	111,55
G 1/2-14h.	2	20,95	19,00	80 x 22 x 12,0	159,72	45x14	111,55
G 5/8-14h.	2	22,91	21,00	80 x 22 x 14,5	189,68	55x16	176,94
G 3/4-14h.	2	26,44	24,50	90 x 22 x 16,0	233,28	55x16	176,91
G 1"-11h.	2	33,25	30,75	100 x 25 x 20,0	349,65	65x18	227,52
G 1.1/4-11h.	2	41,91	39,50	125 x 40 x 24,0	562,46	75x20	351,50

BSW

	U.tà	D1 mm	L1 x L2 x mm	MOI €	Ø x L3 mm	CSI €	
W 1/8-40h.	3	3,17	2,55	40x14x2,7	63,15	25x9	63,13
W 1/4-20h.	3	6,35	5,10	50x20x4,9	59,76	25x9	63,13
W 5/16-18h.	3	7,94	6,50	56x20x4,9	69,51	25x9	69,96
W 3/8-16h.	3	9,52	7,90	63x22x5,5	85,92	38x10	75,56
W 5/8-11h.	3	15,87	13,40	80x27x9,0	165,66	45x18	114,42
W 3/4-10h.	3	19,05	16,50	95x32x11,0	220,48	45x18	122,32
W 7/8-9h.	3	22,22	19,25	100x32x14,5	271,87	55x22	181,39
W 1"-8h.	3	25,40	21,75	110x36x14,5	445,94	55x22	181,39

Consultare altre misure disponibili su richiesta.

MASCHIO N°3 PER FILETTARE A MANO, FILETTO METRICO, A SINISTRA E A DESTRA

**M
MF**

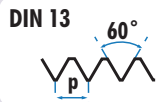

HSS

**DIN
352**

**TOL
6H**

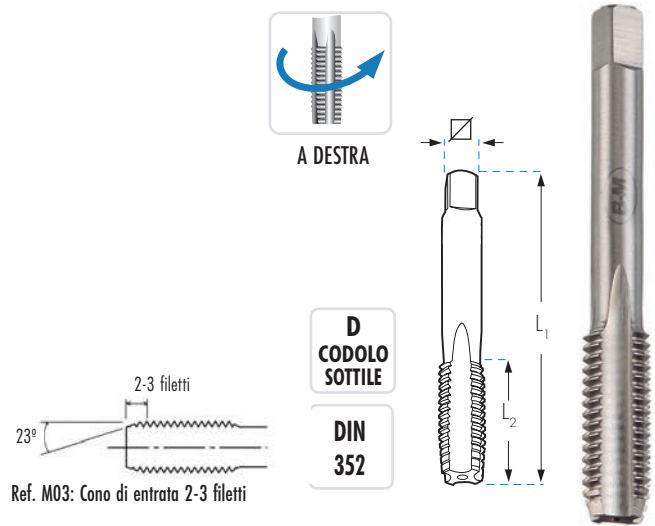

		M03I	
		L ₁ x L ₂ x D ₂ x	€
mm			
M 3x0,50	2,50	D 40 x 11 x 3,50 x 2,70	9,82
M 4x0,70	3,30	D 45 x 13 x 4,50 x 3,40	9,81
M 5x0,80	4,20	D 50 x 16 x 6,00 x 4,90	10,95
M 6x1,00	5,00	D 50 x 19 x 6,00 x 4,90	11,07
M 7x1,00	6,00	D 50 x 19 x 6,00 x 4,90	14,59
M 8x1,25	6,75	D 56 x 22 x 6,00 x 4,90	12,10
M 10x1,50	8,50	D 70 x 24 x 7,00 x 5,50	15,58
M 12x1,75	10,20	D 75 x 29 x 9,00 x 7,00	19,64
M 14x2,00	12,00	D 80 x 30 x 11,00 x 9,00	25,27
M 16x2,00	14,00	D 80 x 32 x 12,00 x 9,00	30,31
M 18x2,50	15,50	D 95 x 40 x 14,00 x 11,00	40,28
M 20x2,50	17,50	D 95 x 40 x 16,00 x 12,00	44,46

Consultare altre misure disponibili su richiesta.

		M03	
		L ₁ x L ₂ x D ₂ x	€
mm			
M 3x0,50	2,50	D 40 x 11 x 3,50 x 2,70	4,91
M 4x0,70	3,30	D 45 x 13 x 4,50 x 3,40	4,90
M 5x0,80	4,20	D 50 x 16 x 6,00 x 4,90	5,47
M 6x1,00	5,00	D 50 x 19 x 6,00 x 4,90	5,53
M 7x1,00	6,00	D 50 x 19 x 6,00 x 4,90	7,29
M 8x1,00	7,00	D 56 x 18 x 6,00 x 4,90	10,32
M 8x1,25	6,75	D 56 x 22 x 6,00 x 4,90	6,05
M 9x1,25	7,75	D 63 x 18 x 7,00 x 5,50	8,21
M 10x1,00	9,00	D 63 x 18 x 7,00 x 5,50	12,14
M 10x1,25	8,80	D 70 x 24 x 7,00 x 5,50	11,30
M 10x1,50	8,50	D 70 x 24 x 7,00 x 5,50	7,79
M 12x1,00	11,00	D 70 x 20 x 9,00 x 7,00	19,89
M 12x1,25	10,75	D 70 x 20 x 9,00 x 7,00	19,83
M 12x1,50	10,50	D 70 x 20 x 9,00 x 7,00	18,29
M 12x1,75	10,20	D 75 x 29 x 9,00 x 7,00	9,82
M 14x1,00	13,00	D 70 x 20 x 11,00 x 9,00	30,89
M 14x1,25	12,80	D 70 x 20 x 11,00 x 9,00	23,04
M 14x1,50	12,50	D 70 x 20 x 11,00 x 9,00	19,74
M 14x2,00	12,00	D 80 x 30 x 11,00 x 9,00	12,64
M 16x1,00	15,00	D 70 x 20 x 12,00 x 9,00	33,69
M 16x1,25	14,75	D 70 x 20 x 12,00 x 9,00	33,89
M 16x1,50	14,50	D 70 x 20 x 12,00 x 9,00	24,27
M 16x2,00	14,00	D 80 x 32 x 12,00 x 9,00	15,16
M 18x1,50	16,50	D 80 x 22 x 14,00 x 11,00	24,77
M 18x2,50	15,50	D 95 x 40 x 14,00 x 11,00	20,14
M 20x1,50	18,50	D 80 x 22 x 16,00 x 12,00	26,83
M 20x2,50	17,50	D 95 x 40 x 16,00 x 12,00	22,23
M 22x2,50	19,50	D 100 x 40 x 18,00 x 14,50	31,08
M 24x3,00	21,00	D 110 x 50 x 18,00 x 14,50	36,02
M 27x3,00	24,00	D 110 x 50 x 20,00 x 16,00	46,88
M 30x3,50	26,50	D 125 x 50 x 22,00 x 18,00	59,41

CALIBRI PER IL CONTROLLO DEI PASSI DELLA FILETTATURA



	TIPI DI FILETTATURA	INTERVALLO DI PASSI		GAM
		Metrici	Inglesì	€
GAM	Passi filettatura metrica	0,25 - 2,5		12,94
GAMW	Passi filettatura metrica /filettatura inglese	0,25 - 6,0	62h - 4h	17,14

INSIEME DI GUIDE PER FILIERE M3-M12



CG5
M3-M12
14,42 €

PROLUNGA PER MASCHI

DIN
377

DIN 10

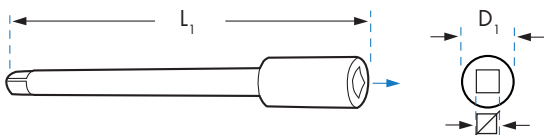

Stessa misura del attacco quadro in entrambe le zone maschio e femmina.

	$\square \times L_1$ mm	D_1	AL €
AL21	2,1 x 60	6,0	8,50
AL24	2,4 x 70	6,0	8,50
AL27	2,7 x 80	7,0	8,50
AL30	3,0 x 90	7,0	8,50
AL34	3,4 x 95	8,0	9,21
AL38	3,8 x 95	9,0	9,62
AL43	4,3 x 105	10,0	10,72
AL49	4,9 x 110	11,0	10,34
AL55	5,5 x 115	12,0	10,50
AL62	6,2 x 120	14,0	13,15
AL70	7,0 x 125	15,0	14,26
AL80	8,0 x 125	17,0	17,80
AL90	9,0 x 135	19,0	18,29

	$\square \times L_1$ mm	D_1	AL €
AL100	10,0 x 140	21,0	17,87
AL110	11,0 x 150	23,0	21,77
AL120	12,0 x 160	25,0	27,58
AL130	13,0 x 165	27,0	43,15
AL145	14,5 x 175	29,0	42,06
AL160	16,0 x 185	30,0	46,28
AL180	18,0 x 195	33,0	52,76
AL200	20,0 x 220	36,0	70,35
AL220	22,0 x 220	40,0	102,81
AL240	24,0 x 235	42,0	153,18
AL260	26,0 x 245	45,0	166,44
AL290	29,0 x 260	55,0	191,82
AL320	32,0 x 280	55,0	240,70

Massima
Resistenza
150 kg/mm²

GIRAMASCHI IN ACCIAIO FORGIATO

Ref. GAPRO

- Corpo in Acciaio Forgiato.
- Sopporta sforzi fino a 150 kg/mm.
- Massima resistenza e durabilità.

- Maggiore precisione e fermezza nell'attacco.
- La filettatura di precisione forma un insieme solido e robusto.
- Impugnatura antiscivolo, maggiore aderenza.



GAPRO

N° NORMA	N° 0	N° 1	N° 1.1/2	N° 2	N° 3	N° 4	N° 5
	M1-M8 2,00-5,00	M1-M10 2,00-6,30	M1-M12 2,50-7,00	M1-M12 2,50-8,00	M5-M20 4,00-13,00	M5-M27 4,00-16,00	M9-M32 5,50-20,00
€	17,72	18,00	23,91	30,21	42,77	68,37	144,71

Ref. GA

- Corpo in Lega di Zinco.
- Alta resistenza e durabilità.
- Alta precisione e fermezza nell'attacco.



GA

N° NORMA	N° 0	N° 1	N° 1.1/2	N° 2	N° 3	N° 4	N° 5	N° 7	N° 8
	M1-M8 1,50-5,00	M1-M10 2,00-7,00	M1-M12 2,00-8,00	M4-M12 2,50-10,00	M5-M20 3,50-14,00	M9-M27 4,00-15,00	M13-M32 5,50-19,00	M22-M52 14,00-34,00	M33-M64 16,00-40,00
€	9,88	11,96	16,07	20,31	28,75	45,97	97,30	200,74	413,35

GIRAFILIERE IN ACCIAIO

Ref. VA

**DIN
225**



IMPORTANTE: Al momento dell'ordine, indichi lo spessore del girafiliera in base agli spessori delle filiere indicati nella tariffa.

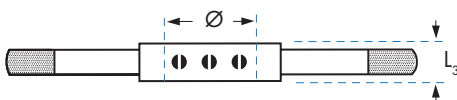

Ø x L3 mm	16x5	20x5	20x7	25x9	30x11	38x10	38x14	45x14	45x18	55x16	55x22	65x18	65x25
€	10,34	11,44	11,44	13,06	15,82	20,68	20,65	25,38	25,58	32,81	34,37	47,02	47,02
Ø x L3 mm	75x20	75x30	90x22	90x36	105x22	105x36	120x22	120x36	130x25	130x36	140x25		
€	81,47	85,27	103,19	111,17	155,01	155,01	403,14	403,14	419,11	419,11	440,73		

VA

Ref. VA

POLLICI



Ø mm	20,60	25,40	38,10	50,80	63,50	76,20	88,90
POLLICI	13/16"	1"	1.1/2"	2"	2.1/2"	3"	3.1/2"
€	11,21	13,29	19,89	29,51	46,56	86,10	109,07

VA

NOTA: I girafiliera con Ø esterno in pollici sono in disuso.

GIRAMASCHI A CRICCHETTO

Ref. TC

TIPO
T

SERIE CORTA



	CAPACITÀ mm min.-max.	Per codoli di maschi		L ₁ mm	PESO g	QUALITÀ	TC
		DIN	ISO				€
TC3B	2,6 - 5,5	M3 - 8	M3 - 6	85	180	1ª Qualità	28,49
TC4B	4,6 - 8,0	M5 - 12	M6 - 12	110	300	1ª Qualità	38,50
TC1B	2,6 - 5,5	M3 - 8	M3 - 6	85	180	2ª Qualità	16,33
TC2B	4,6 - 8,0	M5 - 12	M6 - 12	110	300	2ª Qualità	24,46

Ref. TL

TIPO
T

SERIE LUNGA



	CAPACITÀ mm min.-max.	Per codoli di maschi		L ₁ mm	PESO g	QUALITÀ	TL
		DIN	ISO				€
TL3	2,6 - 5,5	M3 - 8	M3 - 6	250	250	1ª Qualità	44,94
TL4	4,6 - 8,0	M5 - 12	M6 - 12	300	440	1ª Qualità	53,51
TL1	2,6 - 5,5	M3 - 10	M3 - 6	250	250	2ª Qualità	31,59
TL2	4,6 - 8,0	M5 - 12	M6 - 12	300	440	2ª Qualità	37,65

ESPOSITORE IN METACRILATO

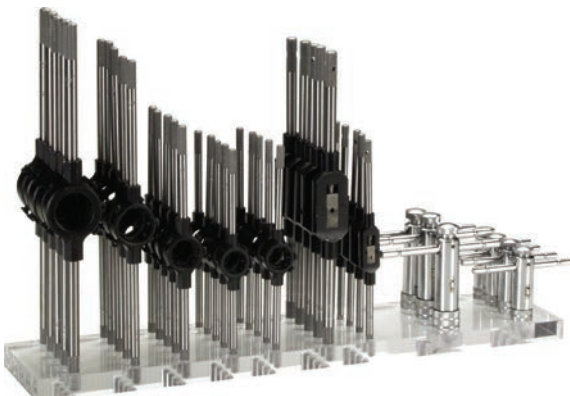

Dimensioni: 500 x 320 x 110 mm

				GV-01
				€
GV-01	Nº <u>1 1/2</u> 5	Nº <u>2</u> 5	<u>20 x 5</u> <u>20 x 7</u> <u>25 x 9</u> 5 5 5 <u>30 x 11</u> <u>38 x 14</u> 5 5	TC1 TC2 4 4 768,24

ASSORTIMENTO DI MASCHI E FILIERE HSS IN SCATOLA METALLICA

**M3
M12**

HSS



Ref. D624

CONTENUTO

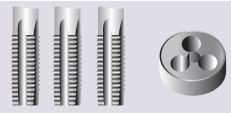
					N° Pezzi	1° Qualità €	2° Qualità €
D624	M3 - M4 - M5 - M6 - M8 - M10 - M12	N° 1.1/2	25 x 9	-	30	228,98	192,35

ASSORTIMENTI DI FILIERE HSS IN SCATOLA METALLICA



**M3
M12**

HSS



Ref. D671

CONTENUTO

			N° Pezzi	1° Qualità €	2° Qualità €
D671	M3 - M4 - M5 - M6 - M8 - M10 - M12	20 x 5 30 x 11 20 x 7 38 x 14 25 x 9	12	228,29	187,58
D671I (Sinistra)	 M3 - M4 - M5 - M6 - M8 - M10 - M12	20 x 5 30 x 11 20 x 7 38 x 14 25 x 9	12	456,60	375,17

ASSORTIMENTI DI MASCHI E FILIERE HSS E HSSCo IN SCATOLA METALLICA CON GUIDE PER FILIERE
**M3
M12**

HSS
**HSSCo
5%**

Ref. D621



Ref. D655

CONTENUTO

						N° Pezzi	1° Qualità €	2° Qualità €
D621	M3 - M4 - M5 - M6 M8 - M10 - M12	2.5 / 3.3 / 4.2 / 5.0 6.8 / 8.5 / 10.2 mm	N° 1 N° 2	20 x 5 20 x 7 25 x 9 30 x 11 38 x 14	TC1	43	486,16	409,90
D652	M3 - M4 - M5 - M6 M8 - M10 - M12	2.5 / 3.3 / 4.2 / 5.0 6.8 / 8.5 / 10.2 mm	N° 1 N° 2	20 x 5 20 x 7 25 x 9 30 x 11 38 x 14	-	42	469,91	393,65
D662	M3-M4-M5-M6-M7 M8-M9-M10-M11-M12	-	N° 1 N° 2	20 x 5 20 x 7 25 x 9 30 x 11 38 x 14	TC1	48	734,56	626,78
D651	M3 - M4 - M5 - M6 M8 - M10 - M12	-	N° 1 N° 2	20 x 5 20 x 7 25 x 9 30 x 11 38 x 14	-	35	371,42	316,43
D655* (HSSCo)	M3 - M4 - M5 - M6 M8 - M10 - M12	2.5 / 3.3 / 4.2 / 5.0 6.8 / 8.5 / 10.2 mm	N° 1 N° 2	20 x 5 20 x 7 25 x 9 30 x 11 38 x 14	TC1	43	506,16	445,23
D621I (Sinistra)	M3 - M4 - M5 - M6 M8 - M10 - M12	2.5 / 3.3 / 4.2 / 5.0 6.8 / 8.5 / 10.2 mm	N° 1 N° 2	20 x 5 20 x 7 25 x 9 30 x 11 38 x 14	TC1	43	612,56	534,21

*

**HSSCo
5%**

ASSORTIMENTI DI MASCHI E FILIERE HSS E HSSCo IN SCATOLA METALLICA CON GUIDE PER FILIERE

M3
M12

HSS
HSSCo
5%







Ref. D656



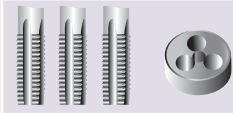

Ref. D657



CONTENUTO

				 + GUIDE		N° Pezzi	1ª Qualità €	2ª Qualità €
D656	M3 - M4 - M5 - M6 M8 - M10 - M12	2.5 / 3.3 / 4.2 / 5.0 6.8 / 8.5 / 10.2 mm	N° 1 N° 2	20x5 20x7 25x9 30x11 38x14	TC1	43	518,61	445,34
D657* (HSSCo)	M3 - M4 - M5 - M6 M8 - M10 - M12	2.5 / 3.3 / 4.2 / 5.0 6.8 / 8.5 / 10.2 mm	N° 1 N° 2	20x5 20x7 25x9 30x11 38x14	TC1	43	539,05	475,78

* **HSSCo
5%**  

ASSORTIMENTI DI MASCHI E FILIERE HSS E HSSCo IN SCATOLA METALLICA
**M3
M20**
**M5
M20**
HSS
**HSSCo
5%**

Ref. D622



Ref. D623

CONTENUTO

						N° Pezzi	1 ^a Qualità €	2 ^a Qualità €
D622	M3 - M4 - M5 - M6 - M8 - M10 - M12 M14 - M16 - M18 - M20	N° 1 N° 3	20x5 20x7 25x9 30x11 38x14 45x18		TC1 TC2	54	868,94	679,54
D658	M3 - M4 - M5 - M6 - M8 - M10 - M12 M14 - M16 - M18 - M20	N° 1 N° 3	20x5 20x7 25x9 30x11 38x14 45x18		-	52	838,57	669,68
D622I (Sinistra)	M3 - M4 - M5 - M6 - M8 - M10 - M12 M14 - M16 - M18 - M20	N° 1 N° 3	20x5 20x7 25x9 30x11 38x14 45x18		TC1 TC2	54	1.366,89	-
D659* (HSSCo)	M3 - M4 - M5 - M6 - M8 - M10 - M12 M14 - M16 - M18 - M20	N° 1 N° 3	20x5 20x7 25x9 30x11 38x14 45x18		-	52	1.648,78	1.406,90
D623	M5 - M6 - M8 - M10 - M12 M14 - M16 - M18 - M20	N° 1 N° 3	20x7 25x9 30x11 38x14 45x18		TC1 TC2	45	832,18	662,15
D663	M5 - M6 - M7 - M8 - M9 - M10 - M12 M14 - M16 - M18 - M20	N° 1 N° 3	20x7 25x9 30x11 38x14 45x18		-	51	1.109,49	968,11

*

**HSSCo
5%**

ASSORTIMENTI DI MASCHI E FILIERE HSS IN SCATOLA METALLICA E DI LEGNO

**M1
M10**

**M5
M12**

**M3
M24**

**M5
M30**

HSS

Maschi e Filiere

Verde







Ref. D628

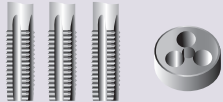

Ref. D626

CONTENUTO

					N° Pezzi	1ª Qualità €	2ª Qualità €
D626	M1 - M1.2 - M1.4 - M1.7 - M2.0 - M2.3 M2.6 - M3 - M3.5 - M4 - M5 - M6 - M8 - M10	N° 0 N° 1	16 x 5 20 x 5 20 x 7 25 x 9 30 x 11	TC1	64	-	1.007,08
D627	M5 - M6 - M7 - M8 - M9 - M10 - M11 - M12	N° 1 N° 2	20 x 7 25 x 9 30 x 11 38 x 14	TC1	39	-	752,32
D625	M3 - M4 - M5 - M6 - M8 - M10 - M12 - M14 M16 - M18 - M20 - M22 - M24	N° 1 N° 4	20 x 5 20 x 7 25 x 9 30 x 11 38 x 14 45 x 18 55 x 22	-	61	1.831,72	1.311,09
D628	M5 - M6 - M8 - M10 - M12 - M14 - M16 M18 - M20 - M22 - M24 - M27 - M30	N° 1 N° 3 N° 5	20 x 7 25 x 9 30 x 11 38 x 14 45 x 18 55 x 22 65 x 25	-	62	-	2.514,13

ASSORTIMENTI DI MASCHI E FILIERE HSS IN SCATOLA METALLICA
MF
HSS

Maschi e Filiere

Verde







Ref. D634

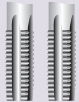

Ref. D636

CONTENUTO

						N° Pezzi	1° Qualità €	2° Qualità €
D634	MF 3 x 0.35 - 4 x 0.5 - 5 x 0.5 MF 6 x 0.75 - 8 x 0.75 - 8 x 1.0 MF 10 x 1.0 - 12 x 1.5	N° 1 N° 2	20 x 5 25 x 9 30 x 11 38 x 10		TC1	31	-	723,13
D635	MF 6 x 0.75 - 8 x 0.75 - 8 x 1.0 - 10 x 1.0 MF 12 x 1.0 - 12 x 1.5 - 14 x 1.25 - 14 x 1.5 MF 16 x 1.5 - 18 x 1.5 - 20 x 1.5	N° 1 N° 3	20 x 7 25 x 9 30 x 11 38 x 10 45 x 14		-	40	1.160,64	1.070,67
D636	MF 6 x 0.75 - 8 x 0.75 - 8 x 1.0 - 10 x 1.0 MF 12 x 1.0 - 12 x 1.5 - 14 x 1.25 - 14 x 1.5 MF 16 x 1.5 - 18 x 1.5 - 20 x 1.5 - 22 x 1.5 MF 24 x 1.5	N° 1 N° 4	20 x 7 25 x 9 30 x 11 38 x 10 45 x 14 55 x 16		-	47	1.592,19	1.428,07

ASSORTIMENTI DI MASCHI E FILIERE HSS IN SCATOLA METALLICA

**BSP
(GAS)**

HSS



Ref. D638

CONTENUTO

						N° Pezzi	1ª Qualità €	2ª Qualità €
D637	G 1/8 - 1/4 - 3/8 - 1/2 - 3/4 - 1"		N° 1 N° 3 N° 5	30 x 11 38 x 10 45 x 14 55 x 16 65 x 18	-	26	1.288,70	1.057,95
D638	G 1/8 - 1/4 - 3/8 - 1/2 - 5/8 - 3/4 - 7/8 - 1"		N° 1 N° 3 N° 5	30 x 11 38 x 10 45 x 14 55 x 16 65 x 18	-	32	1.748,86	1.480,97
D639	G 1/4 - 3/8 - 1/2 - 3/4 - 1" - 1".1/4 - 1".1/2		N° 2 N° 4 N° 7	38 x 10 45 x 14 55 x 16 65 x 18 75 x 20 90 x 22	-	30	3.226,36	2.765,94

BSW

HSS



Ref. D640





CONTENUTO

						N° Pezzi	1ª Qualità €	2ª Qualità €
D640	BSW 1/8 - 3/16 - 1/4 - 5/16 - 3/8 - 7/16 - 1/2		N° 1 N° 2	20 x 5 20 x 7 25 x 9 30 x 11 38 x 14	TC1	36	718,91	624,57
D641	BSW 1/4 - 5/16 - 3/8 - 7/16 - 1/2		N° 1 N° 2	20 x 7 25 x 9 30 x 11 38 x 14	TC1	27	592,67	507,31
D642	BSW 1/4 - 5/16 - 3/8 - 7/16 - 1/2 - 5/8 - 3/4		N° 1 N° 3	20 x 7 25 x 9 30 x 11 38 x 14 45 x 18	-	35	1.060,61	938,83
D643	BSW 1/4 - 5/16 - 3/8 - 7/16 1/2 - 5/8 - 3/4 - 7/8 - 1"		N° 1 N° 4	20 x 7 25 x 9 30 x 11 38 x 14 45 x 18 55 x 22	-	44	1.499,95	1.338,37
D646	BSW 1/4 - 5/16 - 3/8 - 7/16 1/2 - 5/8 - 3/4 - 7/8 - 1" - 1".1/8 1".1/4 - 1".3/8 - 1".1/2		N° 1 N° 3 N° 5	20 x 7 25 x 9 30 x 11 38 x 14 45 x 18 55 x 22 65 x 25	-	62	-	3.882,06

ASSORTIMENTI DI MASCHI E FILIERE HSS IN SCATOLA METALLICA
BSF
HSS

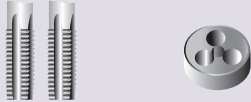
Ref. D648



CONTENUTO

					N° Pezzi	1ª Qualità €	2ª Qualità €
D664	BSF 1/4 - 5/16 - 3/8 - 7/16 - 1/2	N° 1 N° 2	20 x 7 25 x 9 30 x 11 38 x 10	TC1	22	662,74	565,52
D648	BSF 1/4 - 5/16 - 3/8 - 7/16 - 1/2 - 5/8 - 3/4	N° 1 N° 3	20 x 7 25 x 9 30 x 11 38 x 10 45 x 14	-	28	998,09	938,83
D665	BSF 1/4 - 5/16 - 3/8 - 7/16 1/2 - 5/8 - 3/4 - 7/8 - 1"	N° 1 N° 4	20 x 7 25 x 9 30 x 11 38 x 10 45 x 14 55 x 16	-	35	1.745,78	1.489,64

**BSW
BSF**
HSS

Ref. D666

CONTENUTO





					N° Pezzi	1ª Qualità €	2ª Qualità €
D666	BSW 1/4 - 5/16 - 3/8 - 7/16 - 1/2 - 5/8 - 3/4 BSF 1/4 - 5/16 - 3/8 - 7/16 - 1/2 - 5/8 - 3/4	N° 1 N° 3	20 x 7 25 x 9 30 x 11 38 x 14 45 x 18	-	63	1.972,07	1.682,74

ASSORTIMENTI DI MASCHI E FILIERE HSS IN SCATOLA METALLICA



Ref. D660





CONTENUTO

						N° Pezzi	1ª Qualità €	2ª Qualità €
D660	NPT 1/8 - 1/4 - 3/8 - 1/2 - 3/4 - 1"		N°1 N°3 N°5	30 x 11 38 x 14 45 x 18 55 x 22 65 x 25	-	20	1.864,14	1.715,33
D661	NPT 1/8 - 1/4 - 3/8 - 1/2 - 3/4 1" - 1.1/4 - 1.1/2 - 2"		N°2 N°4 N°7	30 x 11 38 x 14 45 x 18 55 x 22 65 x 25 75 x 30 90 x 36 105 x 36	-	29	5.580,26	5.085,81

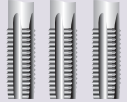

Ref. D650

CONTENUTO

						N° Pezzi	1ª Qualità €	2ª Qualità €
D650	UNC 1/4 - 5/16 - 3/8 - 7/16 - 1/2		N°1 N°2	20 x 7 25 x 9 30 x 11 38 x 14	TC1	27	722,36	628,95
D667	UNC 1/4 - 5/16 - 3/8 - 7/16 - 1/2 - 5/8 - 3/4		N°1 N°2	20 x 7 25 x 9 30 x 11 38 x 14 45 x 18	-	35	1.163,85	993,08
D654	UNC 1/4 - 5/16 - 3/8 - 7/16 1/2 - 5/8 - 3/4 - 7/8 - 1"		N°1 N°4	20 x 7 25 x 9 30 x 11 38 x 14 45 x 18 55 x 22	-	44	1.877,99	1.704,98
D668	UNC 1/4 - 5/16 - 3/8 - 7/16 - 1/2 - 5/8 - 3/4 7/8 - 1" - 1.1/8 - 1.1/4 - 1.3/8 - 1.1/2"		N°1 N°3 N°6	20 x 7 25 x 9 30 x 11 38 x 14 45 x 18 55 x 22 65 x 25	-	62	4.396,75	3.751,68

ASSORTIMENTI DI MASCHI E FILIERE HSS IN SCATOLA METALLICA



UNF

HSS



Ref. D644

CONTENUTO

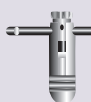
					N° Pezzi	1 ^a Qualità €	2 ^a Qualità €
D644	UNF 1/4 - 5/16 - 3/8 - 7/16 - 1/2	N° 1 N° 2	20 x 7 25 x 9 30 x 11 38 x 10	TC1	22	566,05	476,01
D669	UNF 1/4-5/16-3/8-7/16-1/2-5/8-3/4	N° 1 N° 3	20 x 7 25 x 9 30 x 11 38 x 10 45 x 14	-	28	1.066,85	910,32
D645	UNF 1/4 - 5/16 - 3/8 - 7/16 - 1/2 - 5/8 3/4 - 7/8 - 1"	N° 1 N° 4	20 x 7 25 x 9 30 x 11 38 x 10 45 x 14 55 x 16	-	34	1.308,18	1.150,65

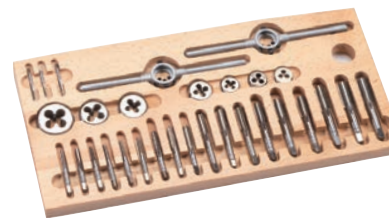

UNC
UNF

HSS

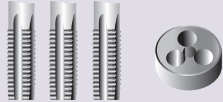

Ref. D670

CONTENUTO

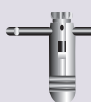
					N° Pezzi	1 ^a Qualità €	2 ^a Qualità €
D670	UNC 1/4 - 5/16 - 3/8 - 7/16 - 1/2 - 5/8 - 3/4 UNF 1/4 - 5/16 - 3/8 - 7/16 - 1/2 - 5/8 - 3/4	N° 1 N° 3	20 x 7 25 x 9 30 x 11 38 x 14 45 x 18	-	35	1.972,07	1.682,74

ASSORTIMENTI DI MASCHI A MANO HSS E TIN IN SCATOLE METALLICHE

Ref. JMB0



Ref. JMB2



Ref. JMBT2

CONTENUTO

					HSS €		TiN* €
JMB2	M3 - M4 - M5 - M6 M8 - M10 - M12	-	-	-	166,76	JMBT2	329,37
JMB0	M3 - M4 - M5 - M6 M8 - M10 - M12	2.5 / 3.3 / 4.2 / 5.0 6.8 / 8.5 / 10.2 mm	-	-	190,23	JMBT0	369,62
JMB1	M3 - M4 - M5 - M6 M8 - M10 - M12	2.5 / 3.3 / 4.2 / 5.0 6.8 / 8.5 / 10.2 mm	N° 1.1/2	-	210,26	JMBT1	387,98
JMB5	M3 - M4 - M5 - M6 M8 - M10 - M12	2.5 / 3.3 / 4.2 / 5.0 6.8 / 8.5 / 10.2 mm	N° 1.1/2	TC1	226,39	JMBT5	406,55
JMBI2 (Sinistra)	M3 - M4 - M5 - M6 M8 - M10 - M12	-	-	-	309,26	JMBIT2	572,17
JMBI0 (Sinistra)	M3 - M4 - M5 - M6 M8 - M10 - M12	2.5 / 3.3 / 4.2 / 5.0 6.8 / 8.5 / 10.2 mm	-	-	358,27	JMBIT0	620,60
JMBI1 (Sinistra)	M3 - M4 - M5 - M6 M8 - M10 - M12	2.5 / 3.3 / 4.2 / 5.0 6.8 / 8.5 / 10.2 mm	N° 1.1/2	-	382,33	JMBIT1	650,62

ASSORTIMENTI DI MASCHI FINITORI A MANO HSS E TIN IN SCATOLE METALLICHE

Ref. JMB3



Ref. JMB4

CONTENUTO

					HSS €		TiN* €
JMB3	M3 - M4 - M5 - M6 M8 - M10 - M12	-	-	-	81,34	JMBT3	101,33
JMB4	M3 - M4 - M5 - M6 M8 - M10 - M12	2.5 / 3.3 / 4.2 / 5.0 6.8 / 8.5 / 10.2 mm	-	-	101,23	JMBT4	133,85
JMB7	M3 - M4 - M5 - M6 M8 - M10 - M12	2.5 / 3.3 / 4.2 / 5.0 6.8 / 8.5 / 10.2 mm	N° 1.1/2	-	115,85	JMBT7	185,66
JMB6	M3 - M4 - M5 - M6 M8 - M10 - M12	2.5 / 3.3 / 4.2 / 5.0 6.8 / 8.5 / 10.2 mm	N° 1.1/2	TC1	125,44	JMBT6	197,89
JMBI3 (Sinistra)	M3 - M4 - M5 - M6 M8 - M10 - M12	-	-	-	109,51	JMBIT3	202,63
JMBI4 (Sinistra)	M3 - M4 - M5 - M6 M8 - M10 - M12	2.5 / 3.3 / 4.2 / 5.0 6.8 / 8.5 / 10.2 mm	-	-	146,76	JMBIT4	268,59

*

TiN

ASSORTIMENTI DI MASCHI A MANO HSSCo IN SCATOLE METALLICHE
HSSCo
5%

Ref. JMBX0

CONTENUTO

INOX	 MOX	 HSSCo			€
JMBX0	M3 - M4 - M5 - M6 M8 - M10 - M12	2.5 / 3.3 / 4.2 / 5.0 6.8 / 8.5 / 10.2 mm	-	-	294,18
JMBX1	M3 - M4 - M5 - M6 M8 - M10 - M12	2.5 / 3.3 / 4.2 / 5.0 6.8 / 8.5 / 10.2 mm	N° 1.1/2	-	309,60
JMBX2	M3 - M4 - M5 - M6 M8 - M10 - M12	-	-	-	278,18

CONTENUTO

 1100 N/mm ²	 MOMD	 HSSCo			€
JMBMD0	M3 - M4 - M5 - M6 M8 - M10 - M12	2.5 / 3.3 / 4.2 / 5.0 6.8 / 8.5 / 10.2 mm	-	-	307,21
JMBMD1	M3 - M4 - M5 - M6 M8 - M10 - M12	2.5 / 3.3 / 4.2 / 5.0 6.8 / 8.5 / 10.2 mm	N° 1.1/2	-	323,18
JMBMD2	M3 - M4 - M5 - M6 M8 - M10 - M12	-	-	-	292,83

SET DI FILIERE HSS IN SCATOLE METALLICHE

Ref. C5B3



CONTENUTO

		HSS €
C5B3	M3 - M4 - M5 - M6 - M8 - M10 - M12	148,93
C5B31 (Sinistra)	M3 - M4 - M5 - M6 - M8 - M10 - M12	297,85



ESTRATTORE DI MASCHI ROTTI PER MASCHI A SCANALATURE DRITE – NON ELICOIDALI



ESTRATTORI SCIOLTI

Ø MASCHIO DA ESTRARRE		MASCHI A MANO	MASCHI A MACCHINA	€/ U.tà
BSW UNC	M			ESTRATTORE COMPLETO
--	M3		W10043	46,79
1/8	M3,2		W10053	46,79
--	M3,5		W10063	46,79
5/32	M4		W10083	46,79
3/16	M5		W10103	46,79
--	M5,5	W10124	W10123	46,79
1/4	M6	W10254	W10253	48,17
5/16	M8	W10314	W10313	50,48
--	M9	W10374	W10373	49,99
3/8	M10	W10404	W10373	49,99
7/16	M11	W10434	W10433	52,78
1/2	M12	W10504	W10503	56,42
9/16	M14	W10564	W10563	77,99
5/8	M16	W10624	W10623	84,88
--	M18	W10684	W10753	105,17
3/4	M20	W10754	W10753	105,17
7/8	M22	W10874	W10873	115,07
1"	M25	W11004	W11003	128,33

ASTA DI RICAMBIO

MASCHI A MANO	MASCHI A MACCHINA	€/ U.tà
		ASTA EXTRA
	W12043	2,48
	W12053	2,48
	W12063	2,48
	W12083	2,48
	W12103	3,72
	W12123	3,72
	W12253	4,53
W12314	W12313	5,11
W12374		5,11
W12404	W12373	5,28
W12434	W12433	5,35
W12504	W12503	6,74
W12564	W12563	7,53
W12624	W12623	9,61
W12684		9,61
W12754	W12753	10,18
W12874	W12873	13,19
W13004	W13003	21,94

3 SEMPLICI PASSI PER L'ESTRAZIONE DI MASCHI ROTTI A SCANALATURE DRITE

Rimuovere i trucioli del maschio rotto. Introdurre le aste dell'estrattore nelle scanalature del maschio rotto con fermezza fino in fondo.



Spingere il supporto verso il basso, fino a toccare il maschio rotto. Far scivolare la boccia verso il basso, fino a toccare la superficie di lavoro.



Applicare un giramaschi all'attacco quadro dell'estrattore. Girare a sinistra più volte fino a sbloccarlo, allora estrarre il maschio rotto.

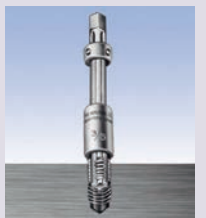

SET DI ESTRATTORI PER MASCHI ROTTI (SCANALATURE DRITE)



N° CANALI	MISURE INCLUSE PER MASCHI A MACCHINA E A MANO E: 3 E 4 CANALI	
W180013	3	M5- M6- M8- M10- M11- M12
W180014	4	3/16 - 1/4 - 5/16 - 3/8 - 7/16 - 1/2
W180023	3	M6- M8 -M10- M11- M12- M16
W180024	4	1/4 - 5/16 - 3/8 - 7/16 - 1/2 - 5/8
W180153	3	M3- M3,2- M3,5- M4-M5- M5,50- M6- M8
W180154	4	M9- M10- M12- M16- M18- M22- M25
		324,38
		364,96
		1.020,86

MASCHI PER FILETTARE A MACCHINA HSSCo
M
MF

DIN 13

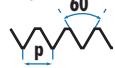
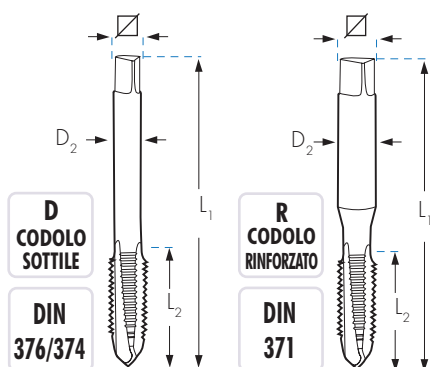
HSSCo
5%
TOL
6H
Vc
12 m/min

		L1 x L2 x D2 x \square mm	M1D	M2D	M3D	M4D	M1R	M2R	M3R	M4R
			FORMA C €	FORMA B €	 15° €	 35° €	FORMA C €	FORMA B €	 15° €	 35° €
M 1x0,25	0,75	R 40 x 5,5 x 2,5 x 2,1					41,91			
M 1,1x0,25	0,85	R 40 x 6 x 2,5 x 2,1					40,77			
M 1,2x0,25	0,95	R 40 x 6 x 2,5 x 2,1					38,67			
M 1,4x0,30	1,10	R 40 x 7 x 2,5 x 2,1					38,67			
M 1,6x0,35	1,25	R 40 x 8 x 2,5 x 2,1					37,98			
M 1,7x0,35	1,35	R 40 x 8 x 2,5 x 2,1					36,57			
M 1,8x0,35	1,45	R 40 x 8 x 2,5 x 2,1					35,69			
M 2x0,40	1,60	R 40 x 8 x 2,8 x 2,1					17,19	18,32	21,27	20,12
M 2,2x0,45	1,75	R 40 x 9 x 2,8 x 2,1					18,56			
M 2,3x0,40	1,90	R 40 x 9 x 2,8 x 2,1					17,10			
M 2,5x0,45	2,05	R 50 x 9 x 2,8 x 2,1					17,19	18,32	28,80	20,12
M 2,6x0,45	2,10	R 50 x 9 x 2,8 x 2,1					16,58	18,65		36,04
M 3x0,50	2,50	R 56 x 11 x 3,5 x 2,7 D 56 x 11 x 2,2 x 1,8	10,05	10,95	15,61	13,18	11,38*	11,45	15,59	14,79
M 3x0,60	2,40	R 56 x 11 x 3,5 x 2,7					20,23	22,05		28,08
M 3,5x0,60	2,90	R 56 x 12 x 4,0 x 3,0 D 56 x 12 x 2,5 x 2,1					16,54	17,19	21,41	20,85
M 3,5x0,75	2,75	R 56 x 12 x 4,0 x 3,0					21,06			
M 4x0,50	3,50	R 63 x 13 x 4,5 x 3,4 D 63 x 13 x 2,8 x 2,1	21,59	24,44		26,11	23,81	25,51		29,53
M 4x0,70	3,30	R 63 x 13 x 4,5 x 3,4 D 63 x 13 x 2,8 x 2,1	10,24	11,11	15,36	13,06	12,70*	12,21	15,75	14,81
M 4x0,75	3,25	R 63 x 13 x 4,5 x 3,4					17,43	19,33		
M 4x0,80	3,20	R 63 x 13 x 4,5 x 3,4					92,55			
M 4,5x0,50	4,00	R 70 x 14 x 6,0 x 4,9						29,68		
M 4,5x0,75	3,75	R 70 x 14 x 6,0 x 4,9					22,35	24,60		
M 5x0,50	4,50	R 70 x 14 x 6,0 x 4,9 D 70 x 11 x 3,5 x 2,7	22,24	25,14		26,39	24,53	26,20		31,51
M 5x0,75	4,50	R 74 x 14 x 6,0 x 4,9 D 70 x 16 x 3,5 x 2,7					21,97	24,85		31,30
M 5x0,80	4,20	R 70 x 16 x 6,0 x 4,9 D 70 x 16 x 3,5 x 2,7	10,24	11,21	14,73	12,54	11,59*	12,29	15,91	14,20
M 5x0,90	4,10	R 70 x 15 x 6,0 x 4,9 D 70 x 16 x 3,5 x 2,7					18,43	23,73		
M 5x1,00	4,00	R 72 x 17 x 6,0 x 4,9					49,34			
M 5,5x0,90	4,60	R 80 x 17 x 6,0 x 4,9					49,34			
M 6x0,50	5,50	R 80 x 17 x 6,0 x 4,9 D 80 x 13 x 4,5 x 3,4	24,87	25,28		27,61	30,91			
M 6x0,75	5,25	R 80 x 13 x 6,0 x 4,9 D 80 x 13 x 4,5 x 3,4	17,34	20,85		23,46	20,02	23,34		28,01
M 6x1,00	5,00	R 80 x 19 x 6,0 x 4,9 D 80 x 19 x 4,5 x 3,4	11,67	12,29	16,59	13,74	12,79*	13,02	16,94	15,57

* Consultare il prezzo delle serie di maschi e filiere a sinistra disponibili a Pag.217

MASCHI PER FILETTARE A MACCHINA HSSCo

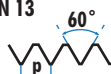



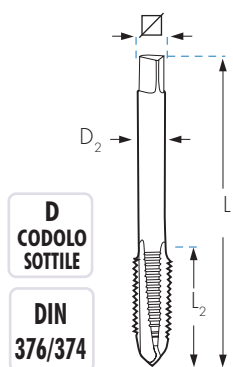

M MF **DIN 13**  **HSSCo 5%** **TOL 6H** **D CODOLO SOTTILE** **DIN 376/374** **Vc 12 m/min** **R CODOLO RINFORZATO** **DIN 371**

	L1 x L2 x D2 x mm	M1D		M2D		M3D		M4D		M1R		M2R		M3R		M4R	
		FORMA C	FORMA B	FORMA C	FORMA B	15°	35°	FORMA C	FORMA B	15°	35°	FORMA C	FORMA B	15°	35°	FORMA C	FORMA B
		€	€	€	€	€	€	€	€	€	€	€	€	€	€	€	€
M 6x1,25	4,75 R 80 x 17 x 6,0 x 4,9									48,48							
M 7x0,75	6,25 D 80 x 13 x 5,5 x 4,3	22,33	25,16				27,61										
M 7x1,00	6,00 R 80 x 19 x 7,0 x 5,5 D 80 x 19 x 5,5 x 4,3	15,98	18,48	19,97	19,22					17,11 *	18,56	22,57	22,33				
M 8x0,50	7,50 D 80 x 13 x 6 x 4,9	31,18															
M 8x0,75	7,25 D 80 x 13 x 6 x 4,9	21,76	26,08				27,61										
M 8x1,00	7,00 D 90 x 20 x 6 x 4,9	18,48	21,21	24,48	22,62												
M 8x1,25	6,80 R 90 x 22 x 8 x 6,2 D 90 x 22 x 6 x 4,9	13,08	13,93	18,87	16,20					14,90 *	14,91	18,52	18,20				
M 8x1,50	6,50 D 90 x 20 x 6 x 4,9	88,02															
M 9x1,00	8,00 D 90 x 20 x 7 x 5,5	25,42	25,26				28,39										
M 9x1,25	7,80 R 90 x 22 x 9 x 7,0 D 90 x 22 x 7 x 5,5	21,61	23,60	27,53	27,93					23,80	21,25	30,82	26,11				
M 10x0,50	9,50 D 90 x 20 x 7 x 5,5	87,21															
M 10x0,75	9,25 D 90 x 16 x 7 x 5,5	29,55	29,20				33,36										
M 10x1,00	9,00 D 90 x 16 x 7 x 5,5	20,45	23,59	28,90	28,59												
M 10x1,25	8,80 D 100 x 22 x 7 x 5,5	23,42	28,17	31,49	31,14												
M 10x1,50	8,50 R 100 x 24 x 10 x 8,0 D 100 x 24 x 7 x 5,5	15,06	16,85	22,45	19,40					16,58 *	18,36	21,33	21,56				
M 11x1,00	10,00 D 90 x 20 x 8 x 6,2	34,03	36,47	92,21	43,72												
M 11x1,25	9,75 D 100 x 22 x 8 x 6,2	35,09	39,00	92,21	43,25												
M 11x1,50	9,50 D 100 x 24 x 8 x 6,2	27,40	31,22	67,24	62,32												
M 12x0,75	11,25 D 100 x 22 x 9 x 7,0	53,74															
M 12x1,00	11,00 D 100 x 22 x 9 x 7,0	27,84	30,97	35,65	35,26												
M 12x1,25	10,75 D 100 x 22 x 9 x 7,0	28,17	31,29	34,13	33,76												
M 12x1,50	10,50 D 100 x 22 x 9 x 7,0	25,18 *	27,90	32,83	32,47												
M 12x1,75	10,20 D 110 x 28 x 9 x 7,0	18,16 *	21,02	27,10	24,75												
M 13x0,75	12,25 D 100 x 22 x 11 x 9,0	93,78															
M 13x1,00	12,00 D 100 x 22 x 11 x 9,0	49,66	50,61														
M 13x1,25	11,75 D 100 x 22 x 11 x 9,0	49,66	56,24														
M 13x1,50	11,50 D 100 x 22 x 11 x 9,0	49,66	50,61														
M 13x1,75	11,25 D 100 x 28 x 11 x 9,0	47,49	56,24														
M 14x0,75	13,25 D 100 x 22 x 11 x 9,0	93,78															
M 14x1,00	13,00 D 100 x 22 x 11 x 9,0	40,70	47,47	54,98	53,30												
M 14x1,25	12,80 D 100 x 22 x 11 x 9,0	35,96	41,62	50,42	49,87												
M 14x1,50	12,50 D 100 x 22 x 11 x 9,0	30,00 *	33,04	39,76	39,32												
M 14x2,00	12,00 D 110 x 30 x 11 x 9,0	29,79 *	32,00	38,36	36,94												
M 15x1,00	14,00 D 100 x 22 x 12 x 9,0	56,97	55,62		61,63												
M 15x1,25	13,75 D 100 x 22 x 12 x 9,0	61,02	66,06														
M 15x1,50	13,50 D 100 x 22 x 12 x 9,0	48,78	55,62	136,83	61,48												
M 15x2,00	13,00 D 110 x 30 x 12 x 9,0	59,70	65,69														
M 16x1,00	15,00 D 100 x 22 x 12 x 9,0	50,64	56,34	76,95	61,43												
M 16x1,25	14,75 D 100 x 22 x 12 x 9,0	54,27	56,84	85,59	61,69												
M 16x1,50	14,50 D 100 x 22 x 12 x 9,0	35,47 *	41,32	49,54	49,01												
M 16x2,00	14,00 D 110 x 32 x 12 x 9,0	35,05 *	35,70	43,73	42,63												
M 17x1,00	16,00 D 100 x 22 x 12 x 9,0	106,83															
M 17x1,25	15,75 D 100 x 22 x 12 x 9,0	106,83															
M 17x1,50	15,50 D 100 x 22 x 12 x 9,0	106,83															
M 18x1,00	17,00 D 110 x 25 x 14 x 11,0	56,71	66,06		75,18												
M 18x1,25	16,75 D 110 x 25 x 14 x 11,0	74,52															
M 18x1,50	16,50 D 110 x 25 x 14 x 11,0	46,94 *	51,66	60,88	59,23												
M 18x2,00	16,00 D 125 x 30 x 14 x 11,0	58,01	70,71	120,47	75,68												

* Consultare il prezzo delle serie di maschi e filiere a sinistra disponibili a Pag.217

MASCHI PER FILETTARE A MACCHINA HSSCo
M
MF

HSSCo
5%
TOL
6H
D
CODOLO
SOTTILE
DIN
376/374
Vc
12
m/min

D
CODOLO
SOTTILE
DIN
376/374

			L ₁ x L ₂ x D ₂ x  <small>mm</small>	M1D	M2D	M3D	M4D
				FORMA C €	FORMA B €	 15° €	 35° €
M 18x2,50	15,50	D	125 x 34 x 14 x 11,0	47,58*	50,86	58,86	60,08
M 19x1,00	18,00	D	110 x 22 x 14 x 11,0	140,37			
M 19x1,25	17,75	D	110 x 25 x 14 x 11,0	139,01			
M 19x1,50	17,50	D	110 x 25 x 14 x 11,0	137,77			
M 20x1,00	19,00	D	125 x 25 x 16 x 12,0	65,74	79,33		84,64
M 20x1,25	18,75	D	125 x 25 x 16 x 12,0	63,63			
M 20x1,50	18,50	D	125 x 25 x 16 x 12,0	53,17*	58,42	68,42	67,67
M 20x2,00	18,00	D	140 x 32 x 16 x 12,0	65,74	76,62		85,17
M 20x2,50	17,50	D	140 x 34 x 16 x 12,0	53,68*	59,55	62,82	64,11
M 21x1,00	20,00	D	125 x 25 x 16 x 12,0	203,79			
M 21x1,25	19,75	D	125 x 25 x 16 x 12,0	203,79			
M 21x1,50	19,50	D	125 x 25 x 16 x 12,0	194,61			
M 22x1,00	21,00	D	125 x 25 x 18 x 14,5	82,09	94,45		102,07
M 22x1,25	20,75	D	125 x 25 x 18 x 14,5	140,37			
M 22x1,50	20,50	D	125 x 25 x 18 x 14,5	63,99	70,39	75,06	70,63
M 22x2,00	20,00	D	140 x 32 x 18 x 14,5	82,09	97,88		102,07
M 22x2,50	19,50	D	140 x 34 x 18 x 14,5	64,97*	71,45	74,49	78,14
M 23x1,00	22,00	D	125 x 25 x 18 x 14,5	198,14			
M 23x1,50	21,50	D	125 x 25 x 18 x 14,5	198,14			
M 24x1,00	23,00	D	140 x 25 x 18 x 14,5	91,47	108,48		124,09
M 24x1,25	22,75	D	140 x 25 x 18 x 14,5	203,79			
M 24x1,50	22,50	D	140 x 28 x 18 x 14,5	74,25	86,54	100,31	99,23
M 24x2,00	22,00	D	140 x 28 x 18 x 14,5	94,72*	109,40		113,70
M 24x3,00	21,00	D	160 x 38 x 18 x 14,5	77,78*	84,17	89,79	94,99
M 25x1,00	24,00	D	140 x 28 x 18 x 14,5	164,57			
M 25x1,25	23,75	D	140 x 28 x 18 x 14,5	275,64			
M 25x1,50	23,50	D	140 x 28 x 18 x 14,5	115,65	115,21		
M 25x2,00	23,00	D	140 x 28 x 18 x 14,5	263,62	273,58		
M 26x1,00	25,00	D	140 x 28 x 18 x 14,5	135,43			
M 26x1,50	24,50	D	140 x 28 x 18 x 14,5	96,78	111,25	187,93	123,94
M 26x2,00	24,00	D	140 x 28 x 18 x 14,5	114,24	115,99		120,33
M 27x1,00	26,00	D	140 x 28 x 20 x 16,0	130,71	135,44		
M 27x1,50	25,50	D	140 x 28 x 20 x 16,0	109,33	122,77	273,13	150,61
M 27x2,00	25,00	D	140 x 28 x 20 x 16,0	120,10*	143,25		

* Consultare il prezzo delle serie di maschi e filiere a sinistra disponibili a Pag.217

MASCHI PER FILETTARE A MACCHINA HSSCo

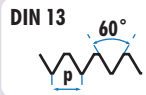
M
MF



HSSCo
5%

TOL
6H







D
CODOLO
SOTTILE

DIN
376/374



Maschi e Filiere

Rosa



			L ₁ x L ₂ x D ₂ x  mm	M1D	M2D	M3D	M4D
				FORMA C €	FORMA B €	 15° €	 35° €
M 27x3,00	24,00	D	160 x 36 x 20 x 16	97,10*	106,47	117,12	116,88
M 28x1,00	27,00	D	140 x 28 x 20 x 16	263,62			
M 28x1,50	26,50	D	140 x 28 x 20 x 16	109,33	127,22	142,23	133,35
M 28x2,00	26,00	D	140 x 28 x 20 x 16	131,20	138,31	167,63	150,25
M 30x1,00	29,00	D	150 x 28 x 22 x 18	148,23	154,27		168,76
M 30x1,50	28,50	D	150 x 28 x 22 x 18	113,95	132,93	154,26	152,56
M 30x2,00	28,00	D	150 x 28 x 22 x 18	137,92*	155,16		169,16
M 30x3,50	26,50	D	180 x 40 x 22 x 18	124,42*	136,80	150,10	149,79
M 32x1,00	31,00	D	150 x 28 x 22 x 18	338,49	359,42		
M 32x1,50	30,50	D	150 x 28 x 22 x 18	144,21	167,82	190,03	
M 32x2,00	30,00	D	150 x 28 x 22 x 18	164,42	192,74		
M 33x1,00	32,00	D	160 x 30 x 25 x 20	323,72			
M 33x1,50	31,50	D	160 x 30 x 25 x 20	165,82	182,64		204,71
M 33x2,00	31,00	D	160 x 30 x 25 x 20	186,38	185,91		210,94
M 33x3,50	29,50	D	180 x 40 x 25 x 20	149,50*	172,05		190,83
M 34x1,50	32,50	D	170 x 30 x 28 x 22	184,68	191,87		
M 34x2,00	32,00	D	160 x 30 x 28 x 22	403,34			
M 35x1,50	33,50	D	170 x 30 x 28 x 22	186,58	200,23		213,44
M 35x2,00	33,00	D	170 x 30 x 28 x 22	358,40	394,56		
M 36x1,50	34,50	D	170 x 30 x 28 x 22	174,23	218,34		254,52
M 36x2,00	34,00	D	170 x 30 x 28 x 22	222,26	227,61		
M 36x3,00	33,00	D	200 x 50 x 28 x 22	238,48	228,04		266,04
M 36x4,00	32,00	D	200 x 50 x 28 x 22	178,28*	210,24	244,19	233,64
M 38x1,50	36,50	D	170 x 30 x 28 x 22	185,74	221,84		
M 38x2,00	36,00	D	170 x 32 x 28 x 22	418,48	460,36		
M 39x1,50	37,50	D	170 x 32 x 32 x 24	309,36			
M 39x2,00	37,00	D	170 x 32 x 32 x 24	309,36			
M 39x3,00	36,00	D	200 x 47 x 32 x 24	404,03			
M 39x4,00	35,00	D	200 x 50 x 32 x 24	222,10	244,73		260,08
M 40x1,50	38,50	D	170 x 30 x 32 x 24	242,87	277,07		
M 40x2,00	38,00	D	170 x 30 x 32 x 24	310,20			
M 40x3,00	37,00	D	200 x 47 x 32 x 24	270,34	278,19		
M 42x1,50	40,50	D	170 x 30 x 32 x 24	265,01	274,52		
M 42x2,00	40,00	D	170 x 30 x 32 x 24	354,88			
M 42x3,00	39,00	D	200 x 45 x 32 x 24	307,55	295,55		
M 42x4,50	37,50	D	200 x 56 x 32 x 24	257,05	284,93		377,74
M 45x1,50	43,50	D	180 x 32 x 36 x 29	316,50	369,02		
M 45x2,00	43,00	D	180 x 32 x 36 x 29	410,90			
M 45x3,00	42,00	D	200 x 47 x 36 x 29	410,90			
M 45x4,50	40,50	D	220 x 58 x 36 x 29	311,98	343,16		
M 48x1,50	46,50	D	190 x 32 x 36 x 29	311,98			
M 48x2,00	46,00	D	190 x 32 x 36 x 29	514,56			
M 48x3,00	45,00	D	220 x 52 x 36 x 29	497,93			
M 48x5,00	43,00	D	250 x 65 x 36 x 29	383,66	421,99		
M 50x1,50	48,50	D	190 x 32 x 36 x 29	378,12			
M 52x1,50	50,50	D	190 x 32 x 40 x 32	369,39			
M 52x2,00	50,00	D	190 x 32 x 40 x 32	619,63			
M 52x3,00	49,00	D	225 x 50 x 40 x 32	636,82			
M 52x5,00	47,00	D	250 x 65 x 40 x 32	416,49	468,12		

* Consultare il prezzo delle serie di maschi e filiere a sinistra disponibili a Pag.217

MASCHI PER FILETTARE A MACCHINA HSSCo

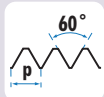
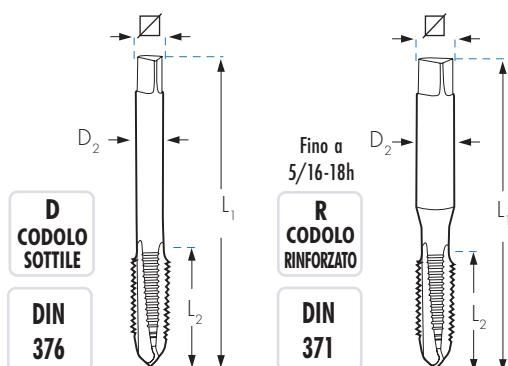
UNC

HSSCo
5%TOL
2BVc
12 m/min

	D1 mm		L1 x L2 x D2 x ∇ mm	M1R	M2R	M4R
				FORMA C	FORMA B	 35°
				€	€	€
UNC n° 4-40h	2,84	2,25	R 56 x 11 x 3,5 x 2,7	14,37	17,10	21,53
UNC n° 5-40h	3,17	2,60	R 56 x 11 x 3,5 x 2,7	14,90	17,88	21,53
UNC n° 6-32h	3,50	2,75	R 56 x 12 x 4,0 x 3,0	14,91	17,94	22,45
UNC n° 8-32h	4,17	3,50	R 63 x 13 x 4,5 x 3,4	14,91	17,94	21,47
UNC n° 10-24h	4,83	3,90	R 70 x 15 x 6,0 x 4,9	14,90	17,88	22,51
UNC n° 12-24h	5,49	4,50	R 80 x 16 x 6,0 x 4,9	15,64	17,88	21,65
UNC 1/4-20h	6,35	5,10	R 80 x 17 x 7,0 x 5,5	16,33	17,81	22,66
UNC 5/16-18h	7,94	6,60	R 90 x 20 x 8,0 x 6,2	20,38	22,47	27,30

CODOLO SOTTILE			M1D	M2D	M4D	
UNC 3/8-16h	9,52	8,00	D 100 x 22 x 7,0 x 5,5	22,95	24,04	28,85
UNC 7/16-14h	11,11	9,40	D 100 x 22 x 8,0 x 6,2	29,86	29,96	38,00
UNC 1/2-13h	12,70	10,75	D 110 x 24 x 9,0 x 7,0	27,31	30,26	38,05
UNC 9/16-12h	14,28	12,20	D 110 x 26 x 11,0 x 9,0	43,92	48,20	54,05
UNC 5/8-11h	15,87	13,50	D 110 x 27 x 12,0 x 9,0	42,64	46,95	61,96
UNC 3/4-10h	19,05	16,50	D 125 x 30 x 14,0 x 11,0	69,55	76,45	86,97
UNC 7/8-9h	22,22	19,50	D 140 x 32 x 18,0 x 14,5	91,50	100,53	131,37
UNC 1"-8h	25,40	22,25	D 160 x 36 x 18,0 x 14,5	120,90	132,09	148,72
UNC 1.1/8-7h	28,57	25,00	D 180 x 40 x 22,0 x 18,0	151,04		182,47
UNC 1.1/4-7h	31,75	28,00	D 180 x 40 x 22,0 x 18,0	177,06		233,43
UNC 1.3/8-6h	34,92	30,75	D 200 x 50 x 28,0 x 22,0	253,09		
UNC 1.1/2-6h	38,10	34,00	D 200 x 50 x 32,0 x 24,0	299,91		

MASCHI PER FILETTARE A MACCHINA HSSCo

UNF

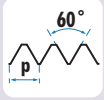

HSSCo
5%

TOL
2B

Vc
12 m/min

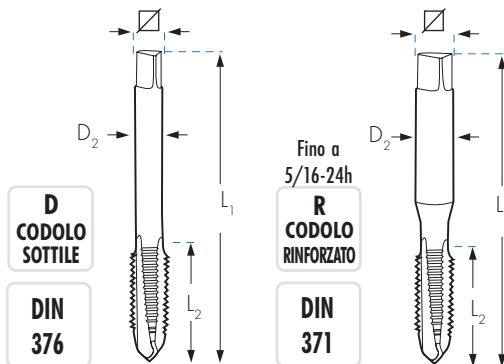

UNF n°	D ₁ mm	D ₂ mm	R	L ₁ × L ₂ × D ₂ × ∇ mm	M1R	M2R	M4R
					FORMA C	FORMA B	35°
					€	€	€
4-48h	2,84	2,35	R	56 × 11 × 3,5 × 2,7	15,64	17,03	21,54
5-44h	3,17	2,70	R	56 × 11 × 3,5 × 2,7	15,64	17,03	21,54
6-40h	3,50	2,95	R	56 × 12 × 4,0 × 3,0	14,17	16,97	21,57
8-36h	4,17	3,50	R	63 × 13 × 4,5 × 3,4	14,17	16,97	21,57
10-32h	4,83	4,10	R	70 × 15 × 6,0 × 4,9	14,17	16,97	21,57
12-28h	5,49	4,60	R	80 × 16 × 6,0 × 4,9	14,29	17,11	21,54
1/4-28h	6,35	5,50	R	80 × 17 × 7,0 × 5,5	15,89	17,03	21,49
5/16-24h	7,94	6,90	R	90 × 20 × 8,0 × 6,2	18,75	21,47	26,03

CODOLO SOTTILE				M1D	M2D	M4D	
UNF	D ₁ mm	D ₂ mm	D				
3/8-24h	9,52	8,50	D	90 × 16 × 7,0 × 5,5	20,80	24,04	29,86
7/16-20h	11,11	9,90	D	100 × 22 × 8,0 × 6,2	23,66	28,54	37,78
1/2-20h	12,70	11,50	D	100 × 22 × 9,0 × 7,0	23,80	28,66	38,13
9/16-18h	14,29	12,90	D	100 × 22 × 11,0 × 9,0	35,70	43,00	54,22
5/8-18h	15,87	14,50	D	100 × 22 × 12,0 × 9,0	35,84	43,12	60,58
3/4-16h	19,05	17,50	D	110 × 25 × 14,0 × 11,0	54,18	65,23	77,50
7/8-14h	22,22	20,40	D	125 × 25 × 18,0 × 14,5	68,12	82,04	118,53
1"-12h	25,40	23,25	D	140 × 28 × 18,0 × 14,5	82,89	104,52	129,52
UNS 1"-14h	25,40	23,60	D	140 × 28 × 18,0 × 14,5	91,36	107,48	139,51
UNF 1.1/8-12h	28,57	26,50	D	150 × 28 × 22,0 × 18,0	146,20		
UNF 1.1/4-12h	31,75	29,50	D	150 × 28 × 22,0 × 18,0	184,76		
UNF 1.1/2-12h	38,10	36,00	D	170 × 30 × 32,0 × 24,0	310,07		

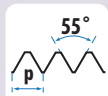
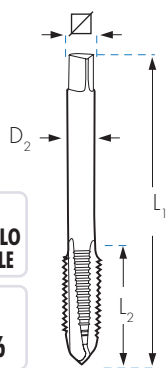
MASCHI PER FILETTARE A MACCHINA HSSCo
**BSP
(GAS)**

**HSSCo
5%**
**TOL
ISO 228**
INOX
**Vc
12 m/min**
**Vc
6 m/min**

**D
CODOLO
SOTTILE**
**DIN
5156**

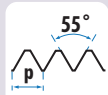
	D1 mm		L1 x L2 x D2 x ∇ mm	M1D	M2D	M3D	M4D	M2DX	M4DX
				FORMA C	FORMA B	15°	35°	FORMA B	35°
				€	€	€	€	€	€
G 1/8-28h.	9,728	8,80	D 90 x 16 x 7 x 5,5	28,14*	30,35	32,64	34,14	44,00	49,42
G 1/4-19h.	13,157	11,80	D 100 x 22 x 11 x 9,0	36,42*	40,10	46,86	48,58	54,13	61,15
G 3/8-19h.	16,662	15,25	D 100 x 22 x 12 x 9,0	44,70*	46,38	55,97	58,53	64,21	77,67
G 1/2-14h.	20,955	19,00	D 125 x 25 x 16 x 12,0	59,07*	64,99	70,60	72,31	93,96	108,27
G 5/8-14h.	22,911	21,00	D 125 x 25 x 18 x 14,5	73,61*	72,82	87,91	86,10		
G 3/4-14h.	26,441	24,50	D 140 x 28 x 20 x 16,0	92,45	101,76	110,51	115,57	151,26	199,17
G 7/8-14h.	30,201	28,25	D 150 x 28 x 22 x 18,0	100,01	105,19	148,63	148,63		
G 1"-11h.	33,249	30,75	D 160 x 30 x 25 x 20,0	143,51	148,90	169,68	177,47		
G 1.1/8-11h.	37,897	35,50	D 170 x 30 x 28 x 22,0	197,74	215,69		262,62		
G 1.1/4-11h.	41,910	39,50	D 170 x 30 x 32 x 24,0	244,56	257,33		277,56		
G 1.3/8-11h.	44,323	42,00	D 180 x 32 x 36 x 29,0	307,56			416,17		
G 1.1/2-11h.	47,803	45,25	D 190 x 32 x 36 x 29,0	269,99	376,35		406,06		
G 1.3/4-11h.	53,746	51,25	D 190 x 32 x 40 x 32,0	487,52	469,82				
G 2"-11h.	59,614	57,00	D 220 x 36 x 45 x 35,0	621,77	635,88				

* Disponibili anche con filettatura sinistra al doppio del prezzo.

BSF

**HSSCo
5%**
**TOL
ISO 228**
**Vc
12 m/min**
**D
CODOLO
SOTTILE**
**DIN
5156**

	D1 mm		L1 x L2 x D2 x ∇ mm	M1D
				FORMA C
				€
BSF 3/16-32h.	4,762	4,00	D 70 x 16 x 3,5 x 2,7	65,87
BSF 1/4-26h.	6,350	5,20	D 80 x 17 x 4,5 x 3,4	28,80
BSF 5/16-22h.	7,938	6,60	D 90 x 20 x 6,0 x 4,9	34,23
BSF 3/8-20h.	9,525	8,10	D 100 x 22 x 7,0 x 5,5	35,96
BSF 7/16-18h.	11,113	9,50	D 100 x 22 x 8,0 x 6,2	48,47
BSF 1/2-16h.	12,700	11,00	D 110 x 24 x 9,0 x 7,0	54,84
BSF 9/16-16h.	14,287	12,50	D 110 x 25 x 11,0 x 9,0	58,04
BSF 5/8-14h.	15,876	14,00	D 110 x 27 x 12,0 x 9,0	77,38
BSF 3/4-12h.	19,051	16,50	D 125 x 30 x 14,0 x 11,0	91,58
BSF 7/8-11h.	22,226	19,50	D 140 x 32 x 18,0 x 14,5	127,31
BSF 1"-10h.	25,400	22,50	D 160 x 36 x 18,0 x 14,5	147,98

MASCHI PER FILETTARE A MACCHINA HSSCo

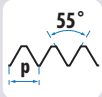
BSW





HSSCo
5%

TOL
Classe 2

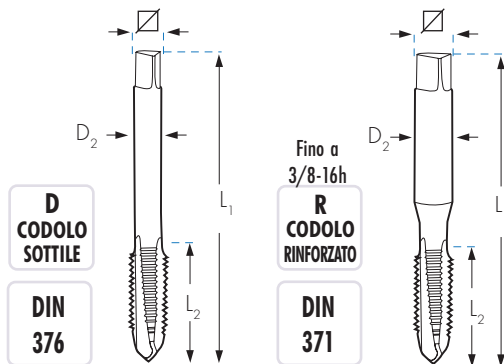
Vc
12 m/min



	D1 mm		L1 x L2 x D2 x 	M1R	M2R	M3R	M4R
				FORMA C	FORMA B	15°	35°
				€	€	€	€
W 3/32-48h.	2,38	1,80	R 50 x 9 x 2,8 x 2,1	20,49	19,97		
W 1/8-40h.	3,17	2,55	R 56 x 11 x 3,5 x 2,7	16,21 *	17,90	19,46	20,35
W 5/32-32h.	3,97	3,10	R 63 x 13 x 4,5 x 3,4	16,21	17,90	19,46	20,35
W 3/16-24h.	4,76	3,60	R 70 x 15 x 6,0 x 4,9	20,12	21,33	19,46	20,35
W 7/32-24h.	5,56	4,40	R 80 x 16 x 6,0 x 4,9	24,61	26,03		
W 1/4-20h.	6,35	5,10	R 80 x 17 x 7,0 x 5,5	17,33	18,10	22,08	22,80
W 5/16-18h.	7,94	6,50	R 90 x 20 x 8,0 x 6,2	20,57	22,95	25,77	26,95
W 3/8-16h.	9,52	7,90	R 100 x 22 x 10,0 x 8,0	21,73	25,68	28,63	29,95

CODOLO SOTTILE				M1D	M2D	M3D	M4D
W 7/16-14h.	11,11	9,25	D 100 x 22 x 8,0 x 6,2	30,22	33,23	37,82	38,08
W 1/2-12h.	12,70	10,50	D 110 x 24 x 9,0 x 7,0	28,99	31,56	36,22	37,88
W 9/16-12h.	14,29	12,00	D 110 x 26 x 11,0 x 9,0	41,55	43,64	51,95	54,33
W 5/8-11h.	15,87	13,40	D 110 x 27 x 12,0 x 9,0	39,34	43,22	49,12	51,37
W 3/4-10h.	19,05	16,50	D 125 x 30 x 14,0 x 11,0	55,06	60,58	65,82	68,83
W 7/8-9h.	22,22	19,25	D 140 x 32 x 18,0 x 14,5	71,30	78,39	89,08	89,08
W 1"-8h.	25,40	21,75	D 160 x 36 x 18,0 x 14,5	89,61	98,51	111,80	116,93
W 1.1/8-7h.	28,57	24,75	D 180 x 40 x 22,0 x 18,0	121,53	127,79	195,47	
W 1.1/4-7h.	31,75	27,75	D 180 x 40 x 22,0 x 18,0	176,56	175,19		
W 1.3/8-6h.	34,92	30,50	D 200 x 50 x 28,0 x 22,0	290,20	304,93		
W 1.1/2-6h.	38,10	33,50	D 200 x 50 x 32,0 x 24,0	314,99	331,29		
W 1.5/8-5h.	41,27	46,50	D 220 x 65 x 32,0 x 24,0	439,67	462,44		
W 1.3/4-5h.	44,45	39,00	D 220 x 58 x 36,0 x 29,0	453,52	498,88		
W 1.7/8-4,5h.	47,62	42,00	D 250 x 75 x 36,0 x 29,0	525,84	553,07		
W 2"-4,5h.	50,80	44,50	D 250 x 65 x 40,0 x 32,0	649,07			

* Disponibili anche con filettatura sinistra al doppio del prezzo.

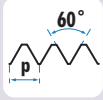
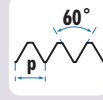
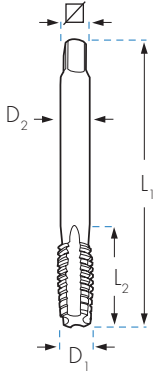
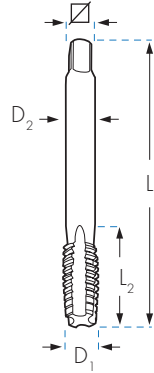
MASCHI PER FILETTARE A MACCHINA HSSCo
UNJC

HSSCo
5%
TOL
3B
UNJF

HSSCo
5%
TOL
3B
Vc
12 m/min

Vc
12 m/min

	D1 mm		L1 x L2 x D2 x ∇ mm	MTR
				FORMA C €
UNJC n° 4-40h	2,84	2,25	R 56 x 11 x 3,5 x 2,7	40,68
UNJC n° 5-40h	3,17	2,60	R 56 x 11 x 3,5 x 2,7	40,68
UNJC n° 6-32h	3,50	2,75	R 56 x 12 x 4,0 x 3,0	40,68
UNJC n° 8-32h	4,17	3,50	R 63 x 13 x 4,5 x 3,4	40,68
UNJC n°10-24h	4,83	3,90	R 70 x 15 x 6,0 x 4,9	40,68
UNJC n°12-24h	5,49	4,50	R 80 x 16 x 6,0 x 4,9	42,67
UNJC 1/4-20h	6,35	5,10	R 80 x 17 x 7,0 x 5,5	37,96
UNJC 5/16-18h	7,94	6,60	R 90 x 20 x 8,0 x 6,2	42,95
UNJC 3/8-16h	9,52	8,00	R 100 x 22 x 8,0 x 6,2	48,96

	D1 mm		L1 x L2 x D2 x ∇ mm	MTR
				FORMA C €
UNJF n° 4-48h	2,84	2,35	R 56 x 11 x 3,5 x 2,7	44,63
UNJF n° 5-44h	3,17	2,70	R 56 x 11 x 3,5 x 2,7	44,63
UNJF n° 6-40h	3,50	2,95	R 56 x 12 x 4,0 x 3,0	44,63
UNJF n° 8-36h	4,17	3,50	R 63 x 13 x 4,5 x 3,4	44,63
UNJF n°10-32h	4,83	4,10	R 70 x 15 x 6,0 x 4,9	44,63
UNJF n°12-28h	5,49	4,60	R 80 x 16 x 6,0 x 4,9	44,63
UNJF 1/4-28h	6,35	5,50	R 80 x 17 x 7,0 x 5,5	34,64
UNJF 5/16-24h	7,94	6,90	R 90 x 20 x 8,0 x 6,2	38,74
UNJF 3/8-24h	9,52	8,50	R 90 x 16 x 7,0 x 6,2	42,41

CODOLO SOTTILE PASSI NORMALI				MID
UNJC 7/16-14h	11,11	9,40	D 110 x 24 x 9,0 x 7,0	67,52
UNJC 1/2-13h	12,70	10,75	D 110 x 26 x 11,0 x 9,0	73,30
UNJC 9/16-12h	14,28	12,20	D 110 x 27 x 12,0 x 9,0	100,73
UNJC 5/8-11h	15,87	13,50	D 110 x 27 x 12,0 x 9,0	110,05
UNJC 3/4-10h	19,05	16,50	D 125 x 30 x 14,0 x 11,0	129,56
UNJC 7/8-9h	22,22	19,50	D 140 x 32 x 18,0 x 14,5	170,48
UNJC 1"-8h	25,40	22,25	D 160 x 36 x 18,0 x 14,5	225,25

CODOLO SOTTILE PASSI NORMALI				MID
UNJF 7/16-20h	11,11	9,90	D 100 x 22 x 8,0 x 6,2	58,25
UNJF 1/2-20h	12,70	11,50	D 100 x 22 x 9,0 x 7,0	62,03
UNJF 9/16-18h	14,29	12,90	D 100 x 22 x 11,0 x 9,0	76,21
UNJF 5/8-18h	15,87	14,50	D 100 x 22 x 12,0 x 9,0	85,80
UNJF 3/4-16h	19,05	17,50	D 110 x 25 x 14,0 x 11,0	109,76
UNJF 7/8-14h	22,22	20,40	D 125 x 25 x 18,0 x 14,5	138,03
UNJF 1"-12h	25,40	23,25	D 140 x 28 x 18,0 x 14,5	153,90

MASCHI PER FILETTARE A MACCHINA HSSCo

BSPB **DIN 2999** **55°** **HSSCo 5%** **DIN 374** **FORMA C**

BSPT **BS21 ISO7/1** **55°** **HSSCo 5%** **DIN 5156** **FORMA C**

FILETTATURA CILINDRICA INGLESE PER TUBI

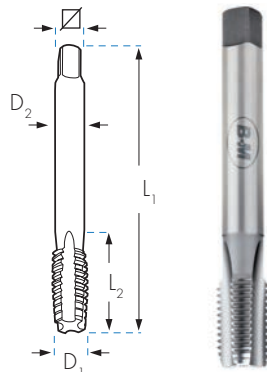

FILETTATURA CONICA INGLESE PER TUBI

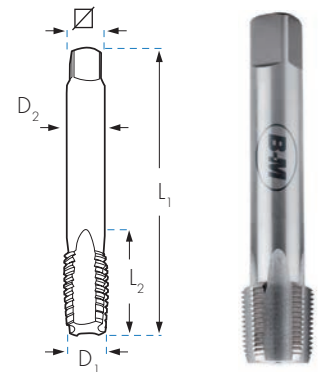

	D1 mm	L1 x L2 x D2 x ∇ mm	MTD	€
Rp 1/16-28h.	7,72	D 90 x 16 x 6 x 4,9		
Rp 1/8-28h.	9,73	D 90 x 16 x 7 x 5,5		48,98
Rp 1/4-19h.	13,16	D 100 x 22 x 11 x 9,0		67,66
Rp 3/8-19h.	16,66	D 100 x 22 x 12 x 9,0		81,01
Rp 1/2-14h.	20,95	D 125 x 25 x 16 x 12,0		102,37
Rp 3/4-14h.	26,44	D 140 x 28 x 20 x 16,0		160,31
Rp 1"-11h.	33,25	D 160 x 30 x 25 x 20,0		248,74
Rp 1.1/4-11h.	41,91	D 170 x 30 x 32 x 24,0		
Rp 1.1/2-11h.	46,80	D 190 x 32 x 36 x 29,0		
Rp 2"-11h.	59,61	D 220 x 36 x 45 x 35,0		

	D1 mm	∇	L1 x L2 x D2 x ∇ mm	MTD	€
Rc 1/16-28h.	7,72		D 90 x 14 x 6 x 4		
Rc 1/8-28h.	9,73	8,30	D 90 x 15 x 7 x 5		46,64
Rc 1/4-19h.	13,16	11,00	D 100 x 19 x 11 x 9		63,54
Rc 3/8-19h.	16,66	14,50	D 100 x 21 x 12 x 9		78,49
Rc 1/2-14h.	20,95	18,10	D 125 x 26 x 16 x 12		109,07
Rc 5/8-14h.	22,91	21,00	D 140 x 36 x 18 x 19		224,50
Rc 3/4-14h.	26,44	23,50	D 140 x 28 x 20 x 16		150,98
Rc 7/8-14h.	30,20	28,25	D 160 x 36 x 22 x 18		392,23
Rc 1"-11h.	33,25	29,60	D 160 x 33 x 25 x 20		280,39

NPS (M) **ANSI B 1.20.1** **60°** **HSSCo 5%** **DIN 374** **FORMA C**

NPT **ANSI B 1.20.1** **60°** **HSSCo 5%** **DIN 374** **FORMA C**

FILETTATURA CILINDRICA AMERICANA PER TUBI

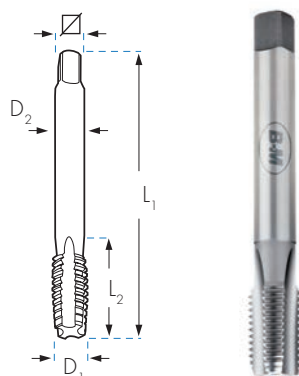

FILETTATURA CONICA AMERICANA PER TUBI

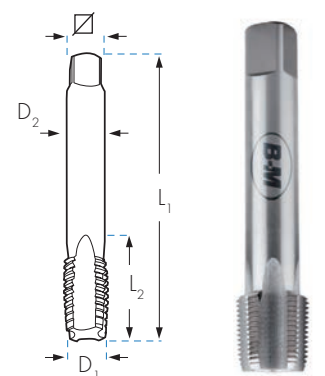

	D1 mm	∇	L1 x L2 x D2 x ∇ mm	MTD	€
NPS 1/8-27h.	10,20	8,90	D 90 x 16 x 7 x 5,5		131,02
NPS 1/4-18h.	13,60	11,70	D 100 x 22 x 11 x 9,0		187,50
NPS 3/8-18h.	17,00	15,00	D 100 x 22 x 12 x 9,0		257,12
NPS 1/2-14h.	21,20	18,60	D 125 x 25 x 16 x 12,0		352,58
NPS 3/4-14h.	26,55	24,00	D 140 x 28 x 20 x 16,0		521,23
NPS 1"-11,5 h.	33,20	30,00	D 160 x 30 x 25 x 20,0		674,03
NPS 1.1/4-11,5h.	41,60		D 170 x 30 x 32 x 24,0		
NPS 1.1/2-11,5h.	47,68		D 190 x 32 x 36 x 29,0		
NPS 2"-11,5h.	59,71		D 220 x 36 x 45 x 35,0		

	D1 mm	∇	L1 x L2 x D2 x ∇ mm	MTD	€
NPT 1/16-27h.	7,89	6,2	D 90 x 14 x 6 x 5		42,28
NPT 1/8-27h.	10,24	8,5	D 90 x 15 x 8 x 6		44,22
NPT 1/4-18h.	13,62	11,0	D 100 x 19 x 11 x 9		59,31
NPT 3/8-18h.	17,05	14,5	D 100 x 21 x 12 x 9		71,91
NPT 1/2-14h.	21,22	17,8	D 125 x 26 x 16 x 12		99,15
NPT 3/4-14h.	26,57	23,0	D 140 x 28 x 20 x 16		153,65
NPT 1"-11,5h.	33,23	29,0	D 160 x 33 x 25 x 20		199,68
NPT 1.1/4-11,5h.	41,98	37,5	D 170 x 36 x 32 x 24		262,65
NPT 1.1/2-11,5h.	48,05	44,0	D 190 x 37 x 36 x 29		429,32
NPT 2"-11,5h.	60,09	56,0	D 220 x 41 x 45 x 35		673,44

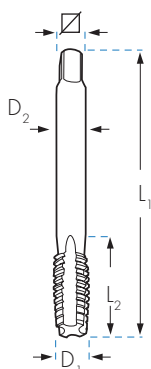
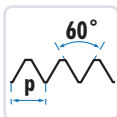
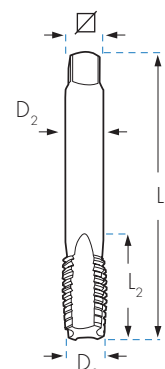
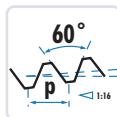
MASCHI PER FILETTARE A MACCHINA HSSCo
NPSF
HSSCo
5%
DIN
374
FORMA
C

FILETTATURA PER TUBI
AMERICANA CILINDRICA
NPTF
HSSCo
5%
DIN
374
FORMA
C

FILETTATURA PER TUBI
AMERICANA CONICA A TENUTA STAGNA

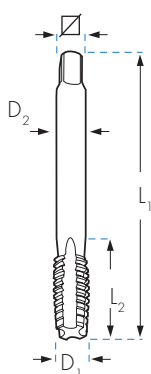
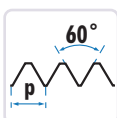
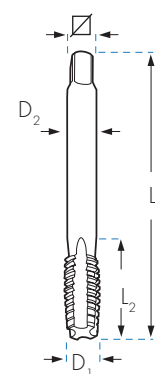
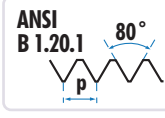
	D1 mm		L1 x L2 x D2 x \square mm	MID €
NPSF 1/8-27h.	10,05	8,75	D 90 x 16 x 7 x 5,5	158,02
NPSF 1/4-18h.	13,33	11,30	D 100 x 22 x 11 x 9,0	217,82
NPSF 3/8-18h.	16,78	14,70	D 100 x 22 x 12 x 9,0	309,87
NPSF 1/2-14h.	20,87	18,20	D 125 x 25 x 16 x 12,0	386,41
NPSF 3/4-14h.	26,23	23,50	D 140 x 28 x 20 x 16,0	632,42
NPSF 1"-11,5h.	32,81	29,50	D 160 x 30 x 25 x 20,0	

	D1 mm		L1 x L2 x D2 x \square mm	MID €
NPTF 1/16-27h.	7,87	6,20	D 90 x 14 x 12,0 x 6	
NPTF 1/8-27h.	10,22	8,50	D 90 x 15 x 12,0 x 7	100,73
NPTF 1/4-18h.	13,58	11,00	D 100 x 21 x 17,5 x 11	141,30
NPTF 3/8-18h.	17,02	14,50	D 110 x 21 x 17,6 x 12	181,54
NPTF 1/2-14h.	21,21	17,80	D 140 x 27 x 22,8 x 16	236,32
NPTF 3/4-14h.	26,56	23,00	D 140 x 27 x 23,0 x 20	366,10

MF
HSSCo
5%
TOL
6H
FORMA
C
DIN
374

FILETTATURA METRICA FINE PER TUBI DI
CONDUZIONE ELETTRICA
EN 60423
PG
HSSCo
5%
DIN
40430
FORMA
C

FILETTATURA PER TUBI
DI CONDUZIONE
ELETTRICA

	D1 mm		L1 x L2 x D2 x \square mm	MID €
MF 12 x 1,50	12	10,5	D 100 x 22 x 9 x 7,0	25,18
MF 16 x 1,50	16	14,5	D 100 x 22 x 12 x 9,0	35,47
MF 20 x 1,50	20	18,5	D 125 x 25 x 16 x 12,0	53,17
MF 25 x 1,50	25	23,5	D 140 x 28 x 18 x 14,5	115,65
MF 32 x 1,50	32	30,5	D 150 x 28 x 22 x 18,0	144,21
MF 40 x 1,50	40	38,5	D 170 x 30 x 32 x 24,0	242,87
MF 50 x 1,50	50	48,5	D 190 x 32 x 36 x 29,0	378,12
MF 63 x 1,50	63	61,5	D 275 x 36 x 50 x 39,0	

	D1 mm		L1 x L2 x D2 x \square mm	MID €
PG 7 - 20h.	12,5	11,50	D 100 x 22 x 9 x 7,0	46,85
PG 9 - 18h.	15,2	14,00	D 100 x 22 x 12 x 9,0	64,87
PG 11 - 18h.	18,6	17,25	D 110 x 25 x 14 x 11,0	84,43
PG 13,5 - 18h.	20,4	19,00	D 125 x 25 x 16 x 12,0	94,80
PG 16 - 18h.	22,5	21,25	D 125 x 25 x 18 x 14,5	111,57
PG 21 - 16h.	28,3	27,00	D 150 x 28 x 22 x 18,0	177,13
PG 29 - 16h.	37,0	35,50	D 170 x 30 x 28 x 22,0	299,42
PG 36 - 16h.	47,0	45,50	D 190 x 32 x 36 x 29,0	486,29
PG 42 - 16h.	54,0	52,50	D 190 x 32 x 40 x 32,0	772,32
PG 48 - 16h.	59,3	58,00	D 220 x 36 x 45 x 35,0	941,51

MASCHI PER FILETTARE A MACCHINA HSSCo

UNx8 HSSCo 5% DIN 374 FORMA C TOL 2B

ANSI/ASME B 1.1 60°

UNEF HSSCo 5% DIN 374 TOL 2B

ANSI/ASME B 1.1 60°

				M1D
		D ₂ mm	L ₁ x L ₂ x mm	FORMA C €
UN 1" 1/8-8h.	25,40	22	180 x 45 x 18	293,04
UN 1" 1/4-8h.	28,50	22	180 x 48 x 18	378,05
UN 1" 3/8-8h.	31,75	28	200 x 56 x 22	428,85
UN 1" 1/2-8h.	35,00	32	200 x 58 x 22	511,87
UN 1" 5/8-8h.	38,10	32	200 x 65 x 24	598,77
UN 1" 3/4-8h.	41,25	36	200 x 50 x 29	729,42
UN 1" 7/8-8h.	44,45	36	225 x 53 x 29	816,14
UN 2"-8h.	47,63	40	225 x 50 x 32	859,70

				M2D	M4D
		D ₂ mm	L ₁ x L ₂ x mm	FORMA B €	35° €
UNEF 1/4-32h.	5,55	7,0	R 82 x 16 x 5,4	96,38	108,30
UNEF 5/16-32h.	7,15	8,4	R 85 x 21 x 6,1	106,18	119,30
UNEF 3/8-32h.	8,70	7,0	D 95 x 22 x 5,4	106,25	119,38
UNEF 7/16-28h.	10,20	8,0	D 100 x 22 x 6,2	141,01	158,45
UNEF 1/2-28h.	11,80	9,0	D 100 x 22 x 7,0	148,54	166,89
UNEF 9/16-24h.	13,20	12,0	D 100 x 24 x 9,0	186,09	209,10
UNEF 5/8-24h.	14,80	12,0	D 100 x 24 x 9,0	211,75	237,93
UNEF 3/4-20h.	17,80	14,0	D 110 x 27 x 11,0	275,41	309,47
UNEF 7/8-20h.	20,95	18,0	D 125 x 26 x 14,5	296,05	317,19
UNEF 1"-20h.	24,20	18,0	D 140 x 28 x 14,5	453,05	509,03

MASCHI PER FILETTARE A MACCHINA HSSCo A SINISTRA

M MF HSSCo 5% FORMA C TOL 6H

DIN 13 60°

V_c 12 m/min

A SINISTRA

D CODOLO SOTTILE DIN 376/374

R CODOLO RINFORZATO DIN 371

				M1R1
			L ₁ x L ₂ x D ₂ x mm	FORMA C €
M 3x0,50	2,50	R	56 x 11 x 3,5 x 2,7	22,77
M 4x0,70	3,30	R	63 x 13 x 4,5 x 3,4	25,40
M 5x0,80	4,20	R	70 x 16 x 6,0 x 4,9	23,17
M 6x1,00	5,00	R	80 x 17 x 6,0 x 4,9	25,59
M 7x1,00	6,00	R	80 x 17 x 7,0 x 5,5	34,22
M 8x1,25	6,80	R	90 x 20 x 8,0 x 6,2	29,81
M 10x1,50	8,50	R	100 x 22 x 10,0 x 8,0	33,16

				M1D1
			L ₁ x L ₂ x D ₂ x mm	FORMA C €
M 12x1,50	10,50	D	100 x 22 x 9,0 x 7,0	50,36
M 12x1,75	10,20	D	110 x 24 x 9,0 x 7,0	36,32
M 14x1,50	12,50	D	100 x 22 x 11,0 x 9,0	59,99
M 14x2,00	12,00	D	110 x 26 x 11,0 x 9,0	59,58
M 16x1,50	14,50	D	100 x 22 x 12,0 x 9,0	70,94
M 16x2,00	14,00	D	110 x 27 x 12,0 x 9,0	70,11
M 18x1,50	16,50	D	110 x 25 x 14,0 x 11,0	93,87
M 18x2,50	15,50	D	125 x 30 x 14,0 x 11,0	95,16
M 20x1,50	18,50	D	125 x 25 x 16,0 x 12,0	106,34
M 20x2,50	17,50	D	140 x 32 x 16,0 x 12,0	107,37
M 22x2,50	19,50	D	140 x 32 x 18,0 x 14,5	129,95
M 24x2,00	22,00	D	140 x 28 x 18,0 x 14,5	189,44
M 24x3,00	21,00	D	160 x 34 x 18,0 x 14,5	155,56
M 27x3,00	24,00	D	160 x 36 x 20,0 x 16,0	194,19
M 30x2,00	28,00	D	150 x 28 x 22,0 x 18,0	275,84
M 30x3,50	26,50	D	180 x 40 x 22,0 x 18,0	248,85
M 33x3,50	29,50	D	180 x 40 x 25,0 x 20,0	299,01
M 36x4,00	32,00	D	200 x 50 x 28,0 x 22,0	356,55

Consultare altre misure disponibili su richiesta.

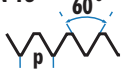
MASCHI A MACCHINA METRICA NORMA ISO 529
**M
MF**
DIN 13

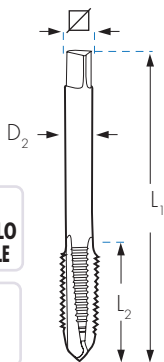
**HSSCo
5%**
**ISO
529**
**TOL
6H**
**D
CODOLO
SOTTILE**

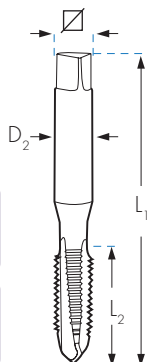
**ISO
529**

**R
CODOLO
RINFORZATO**

**ISO
529**

			L1 x L2 x D2 x \square mm	M1RISO	M2RISO	M4RISO	M5RISO
				FORMA C	FORMA B	35°	DENTI ALTERNATI AI
				€	€	€	€
M 3x0,50	2,50	R	48 x 11 x 3,15 x 2,50	8,46	8,82	10,62	11,45
M 4x0,70	3,30	R	53 x 13 x 4,00 x 3,15	8,46	8,82	10,62	11,45
M 5x0,80	4,20	R	58 x 16 x 5,00 x 4,00	8,46	8,82	10,62	11,45
M 6x1,00	5,00	R	66 x 19 x 6,30 x 5,00	8,46	8,82	10,85	11,45
M 7x1,00	6,00	R	66 x 19 x 7,10 x 5,60		12,03	14,73	
M 8x1,00	7,00	R	69 x 19 x 8,00 x 6,30		15,56	15,39	
M 8x1,25	6,75	R	72 x 22 x 8,00 x 6,30	11,30	11,78	12,17	12,51
M 9x1,25	7,75	R	76 x 20 x 10,00 x 8,00		16,82	18,45	
M 10x1,00	9,00	R	76 x 20 x 10,00 x 8,00		17,86	19,51	
M 10x1,25	8,80	R	76 x 20 x 10,00 x 8,00		21,34	22,04	
M 10x1,50	8,50	R	80 x 24 x 10,00 x 8,00	14,37	14,97	15,68	15,78
CODOLO SOTTILE				M1DISO	M2DISO	M4DISO	M5DISO
M 12x1,00	11,00	D	84 x 24 x 9,00 x 7,10		26,58	26,98	
M 12x1,25	10,75	D	84 x 24 x 9,00 x 7,10		26,85	26,79	
M 12x1,50	10,50	D	89 x 29 x 9,00 x 7,10		23,97	24,85	
M 12x1,75	10,20	D	89 x 29 x 9,00 x 7,10	16,72	19,24	20,38	23,62
M 14x1,00	13,00	D	90 x 25 x 11,20 x 9,00		34,12	41,64	
M 14x1,25	12,80	D	90 x 25 x 11,20 x 9,00		29,91	37,60	
M 14x1,50	12,50	D	95 x 30 x 12,50 x 9,00		23,75	29,64	
M 14x2,00	12,00	D	95 x 30 x 11,20 x 9,00	22,08	23,00	27,85	
M 16x1,00	15,00	D	95 x 25 x 12,50 x 10,00		46,71	48,24	
M 16x1,25	14,75	D	102 x 32 x 12,50 x 10,00		47,13	48,43	
M 16x1,50	14,50	D	102 x 32 x 14,00 x 10,00		33,05	37,12	
M 16x2,00	14,00	D	102 x 32 x 12,50 x 10,00	27,42	28,56	32,30	
M 18x1,50	16,50	D	104 x 29 x 14,00 x 11,20		43,68	53,01	
M 18x2,50	15,50	D	112 x 37 x 14,00 x 11,20	41,29	43,00	53,76	
M 20x1,50	18,50	D	104 x 29 x 14,00 x 11,20		49,67	57,02	
M 20x2,50	17,50	D	112 x 37 x 14,00 x 11,20	46,14	48,07	56,69	
M 22x2,50	19,50	D	118 x 38 x 16,00 x 12,50	53,36	55,58	69,48	
M 24x3,00	21,00	D	130 x 45 x 18,00 x 14,00	60,28	62,79	78,48	
M 27x3,00	24,00	D	135 x 45 x 20,00 x 16,00	74,23	77,32	96,65	
M 30x3,50	26,50	D	138 x 48 x 20,00 x 16,00	110,28	114,88	135,47	

MASCHI A MACCHINA CORTI DIN 352

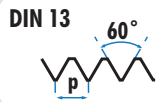
M
MF



HSS

HSSCo
5%

DIN
352

TOL
6H

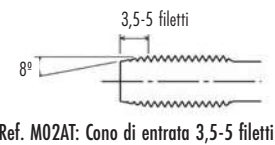
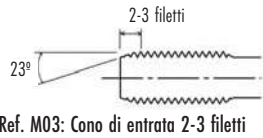

D
CODOLO
SOTTILE
DIN
352

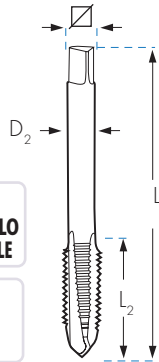

Icona	D	L1 x L2 x D2 x \square mm	M03	M02AT	M03X	M02DIN	M04DIN
			HSS €	ALTEZZA FINITA HSS €	INOX HSSCo €	FORMA B HSS €	35° HSS €
M 3x0,50	2,50	D 40 x 11 x 3,50 x 2,70	4,91	6,38	9,94	9,70	11,68
M 4x0,70	3,30	D 45 x 13 x 4,50 x 3,40	4,90	6,37	9,94	9,70	11,68
M 5x0,80	4,20	D 50 x 16 x 6,00 x 4,90	5,47	7,11	10,08	9,70	11,68
M 6x1,00	5,00	D 50 x 19 x 6,00 x 4,90	5,53	7,20	10,06	9,70	11,94
M 7x1,00	6,00	D 50 x 19 x 6,00 x 4,90	7,29				
M 8x1,00	7,00	D 56 x 18 x 6,00 x 4,90	10,32				
M 8x1,25	6,75	D 56 x 22 x 6,00 x 4,90	6,05	7,87	11,55	12,94	15,09
M 9x1,25	7,75	D 63 x 18 x 7,00 x 5,50	8,21				
M 10x1,00	9,00	D 63 x 18 x 7,00 x 5,50	12,14				
M 10x1,25	8,80	D 70 x 24 x 7,00 x 5,50	11,30				
M 10x1,50	8,50	D 70 x 24 x 7,00 x 5,50	7,79	10,13	15,44	16,46	18,39
M 12x1,00	11,00	D 70 x 20 x 9,00 x 7,00	19,89				
M 12x1,25	10,75	D 70 x 20 x 9,00 x 7,00	19,83				
M 12x1,50	10,50	D 70 x 20 x 9,00 x 7,00	18,29				
M 12x1,75	10,20	D 75 x 29 x 9,00 x 7,00	9,82	12,76	20,16	19,98	24,40
M 14x1,00	13,00	D 70 x 20 x 11,00 x 9,00	30,89				
M 14x1,25	12,80	D 70 x 20 x 11,00 x 9,00	23,04				
M 14x1,50	12,50	D 70 x 20 x 11,00 x 9,00	19,74				
M 14x2,00	12,00	D 80 x 30 x 11,00 x 9,00	12,64	16,43	25,42	25,30	30,63
M 16x1,00	15,00	D 70 x 20 x 12,00 x 9,00	33,69				
M 16x1,25	14,75	D 70 x 20 x 12,00 x 9,00	33,89				
M 16x1,50	14,50	D 70 x 20 x 12,00 x 9,00	24,27				
M 16x2,00	14,00	D 80 x 32 x 12,00 x 9,00	15,16		31,02	31,42	35,53
M 18x1,50	16,50	D 80 x 22 x 14,00 x 11,00	24,77				
M 18x2,50	15,50	D 95 x 40 x 14,00 x 11,00	20,14		40,62	46,51	53,23
M 20x1,50	18,50	D 80 x 22 x 16,00 x 12,00	26,83				
M 20x2,50	17,50	D 95 x 40 x 16,00 x 12,00	22,23		45,73	52,88	56,12
M 22x2,50	19,50	D 100 x 40 x 18,00 x 14,50	31,08			61,13	68,79
M 24x3,00	21,00	D 110 x 50 x 18,00 x 14,50	36,02			69,07	77,70
M 27x3,00	24,00	D 110 x 50 x 20,00 x 16,00	46,88			89,99	98,80
M 30x3,50	26,50	D 125 x 50 x 22,00 x 18,00	59,41			123,27	126,61

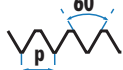
MASCHI A MACCHINA E FILIERE SERIE *Plus* E *Super Plus*
Plus
DIN 13

**TOL
6H**

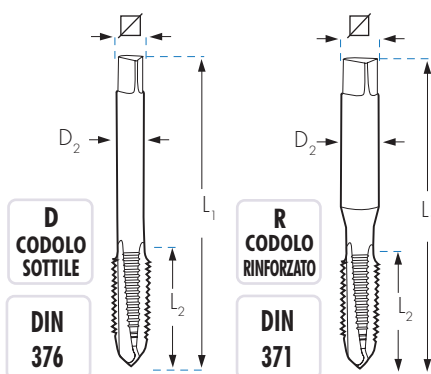
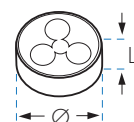
 PER LAVORAZIONI DI ALTA PRODUZIONE
 FABBRICATI IN ACCIAIO SINTERIZZATO

**DIN
22568**
**TOL
6g**
**Vc
14 m/min**
**Vc
16 m/min**
**Vc
17 m/min**
**Vc
20 m/min**

 LAPPATURA E
 ROMPIRUCIOLO

Plus
Plus TiN
Plus LUBE
Super Plus ALTiN

QUALITÀ	M2RP		M4RP		M2RT		M4RT		M2RHL		M4RHL		M2RSP		M4RSP		C5P	
	★★	★★	★★★	★★★	★★★★	★★★★	★★★	★★★	★★★★	★★★★	★★★★	★★★★	★★★★	★★★★	★★★★			
MATERIALE	HSS PM		HSS PM		HSSCo 5%		HSSCo 5%		HSS PM		HSS PM		HSS V3		HSS V3		HSS	
FINITURA	BRILLANTE		BRILLANTE		TiN		TiN		HARD LUBE		HARD LUBE		ALTiN		ALTiN		BRILLANTE	
ANGOLO DELL'ELICA	FORMA B		35°		FORMA B		35°		FORMA B		35°		FORMA B		41°			
	L1 x L2 x D2 x ∠		€	€	€	€	€	€	€	€	€	€	€	€	€	€	Ø x L3 mm	€
M 3x0,50	2,50	R	56 x 11 x 3,5 x 2,7	13,63	16,84	19,79	22,26	22,74	24,63	42,39	44,36	25 x 9	25,57					
M 4x0,70	3,30	R	63 x 13 x 4,5 x 3,4	13,92	16,84	20,87	23,25	23,08	24,96	42,39	44,36	25 x 9	25,57					
M 5x0,80	4,20	R	70 x 16 x 6,0 x 4,9	13,92	16,15	20,87	22,78	23,08	24,96	44,76	45,99	25 x 9	25,57					
M 6x1,00	5,00	R	80 x 17 x 6,0 x 4,9	15,32	17,72	23,14	25,06	25,36	26,42	44,76	45,99	25 x 9	25,57					
M 8x1,00	7,00	D	90 x 20 x 6,0 x 4,9	21,85	25,94	30,23	33,63	35,68	39,71			25 x 9	34,35					
M 8x1,25	6,80	R	90 x 20 x 8,0 x 6,2	17,94	20,60	26,80	29,41	29,92	33,61	56,82	60,55	25 x 9	26,72					
M 10x1,00	9,00	D	90 x 16 x 7,0 x 5,5	24,38	30,58	35,30	40,54	41,67	49,24			30 x 10	41,99					
M 10x1,50	8,50	R	100 x 22 x 10,0 x 8,0	21,09	23,99	32,00	34,90	37,09	41,83	67,71	72,23	30 x 10	38,13					
CODOLO SOTTILE			M2DP	M4DP	M2DT	M4DT	M2DHL	M4DHL	M2DSP	M4DSP								
M 12x1,50	10,50	D	100 x 22 x 9,0 x 7,0	28,92	34,95	40,41	45,52	46,64	53,50			38 x 10	47,50					
M 12x1,75	10,20	D	110 x 24 x 9,0 x 7,0	27,18	32,27	39,65	44,30	41,42	50,17	85,20	92,43	38 x 14	41,93					
M 14x1,50	12,50	D	100 x 22 x 11,0 x 9,0	34,25	42,96	46,67	53,52	54,86	62,90			38 x 10	49,66					
M 14x2,00	12,00	D	110 x 26 x 11,0 x 9,0	33,99	39,41	48,47	53,29	55,44	60,93	87,00	117,13	38 x 14	42,75					
M 16x1,50	14,50	D	100 x 22 x 12,0 x 9,0	42,86	52,84	56,07	64,13	61,39	63,22			45 x 14	68,20					
M 16x2,00	14,00	D	110 x 27 x 12,0 x 9,0	39,99	47,62	55,35	62,34	63,28	69,95	118,75	126,31	45 x 18	57,42					
M 18x2,50	15,50	D	125 x 30 x 14,0 x 11,0	56,66	64,03	70,12	76,50	84,35	94,99	176,25	190,69	45 x 18	57,42					
M 20x2,50	17,50	D	140 x 32 x 16,0 x 12,0	61,24	68,26	79,92	86,11	93,94	106,95	187,84	198,55	45 x 18	57,42					
M 22x2,50	19,50	D	140 x 32 x 18,0 x 14,5	74,09	84,22	93,73	102,29	110,16	120,21			55 x 22	86,17					
M 24x3,00	21,00	D	160 x 34 x 18,0 x 14,5	88,08	100,83	105,63	117,01	124,13	137,50			55 x 22	86,17					

MASCHI A MACCHINA PER LAVORAZIONI SPECIALI HSS-PM

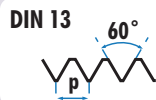
INOX

M



TOL
6H

Vc
6 m/min

Vc
10 m/min

Vc
12 m/min

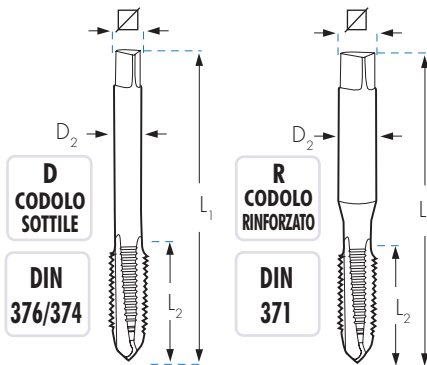

QUALITÀ	M2RX		M4RX		M2RXT		M4RXT		M2RXHL		M4RXHL	
	★★	★★	★★	★★	★★★	★★★	★★★	★★★	★★★★	★★★★	★★★★	★★★★
MATERIALE	HSS PM		HSS PM		HSSCo 5%		HSSCo 5%		HSS PM		HSS PM	
FINITURA	OX		OX		TIN		TIN		HARD LUBE		HARD LUBE	
ANGOLO DELL'ELICA	FORMA B		35°		FORMA B		35°		FORMA B		35°	
			L1 x L2 x D2 x ∇ mm		€	€	€	€	€	€	€	€
M 3x0,50	2,50	R	56 x 11 x 3,5 x 2,7	16,88	19,59	19,73	23,20	26,61	31,30			
M 4x0,70	3,30	R	63 x 13 x 4,5 x 3,4	17,10	19,59	20,71	24,06	27,96	32,76			
M 5x0,80	4,20	R	70 x 16 x 6,0 x 4,9	17,73	20,94	20,71	24,27	27,96	32,76			
M 6x1,00	5,00	R	80 x 17 x 6,0 x 4,9	17,83	21,60	22,68	25,52	30,61	34,44			
M 8x1,00	7,00	D	90 x 20 x 6,0 x 4,9	37,18	40,74							
M 8x1,25	6,80	R	90 x 20 x 8,0 x 6,2	20,90	24,91	25,32	29,11	34,18	39,28			
M 10x1,00	9,00	D	90 x 16 x 7,0 x 5,5	38,32	40,91							
M 10x1,50	8,50	R	100 x 22 x 10,0 x 8,0	24,28	29,20	30,94	34,50	41,76	46,56			
CODOLO SOTTILE				M2DX	M4DX	M2DXT	M4DXT	M2DXHL	M4DXHL			
M 12x1,00	11,00	D	100 x 22 x 9,0 x 7,0	43,46	49,86							
M 12x1,50	10,50	D	100 x 22 x 9,0 x 7,0	44,11	52,16							
M 12x1,75	10,20	D	110 x 24 x 9,0 x 7,0	30,81	43,88	39,74	49,71	55,98	65,56			
M 14x2,00	12,00	D	110 x 26 x 11,0 x 9,0	40,40	57,67	52,81	62,18	74,40	82,39			
M 16x2,00	14,00	D	110 x 27 x 12,0 x 9,0	44,33	63,23	58,44	79,63	82,85	99,66			
M 18x2,50	15,50	D	125 x 30 x 14,0 x 11,0	63,51	89,95	89,87	111,45	132,94	141,79			
M 20x2,50	17,50	D	140 x 32 x 16,0 x 12,0	65,52	105,98	103,64	114,67	141,31	149,70			
M 22x2,50	19,50	D	140 x 32 x 18,0 x 14,5	124,28	131,31	141,15	168,13					
M 24x3,00	21,00	D	160 x 34 x 18,0 x 14,5	130,66	149,97	143,90	171,96					
M 27x3,00	24,00	D	160 x 36 x 20,0 x 16,0	171,15	196,45							
M 30x3,50	26,50	D	180 x 40 x 22,0 x 18,0	218,87	251,22							



- Lubrificazione: **CUT MAGIC XTHICK**
- Si raccomanda l'applicazione dell'olio da taglio CUT MAGIC XTHICK per ottimizzare il processo di filettatura in Inox, Inconel, Titanio, Duplex, ecc...

Ref. ACXT00250

MASCHI *Super Plus* PER FILETTATURA DI LEGHE REFRATTIVE

M

DIN 13

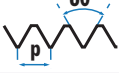
TOL
6HINOX
DUPLEX

Ni

INC

Ti

 PARTICOLARMENTE RACCOMANDATO
 IN APPLICAZIONI AERONAUTICHE
Vc
15 m/minINOX
DUPLEXVc
6 m/minNICKEL
INCONELVc
6 m/min

TITANIO

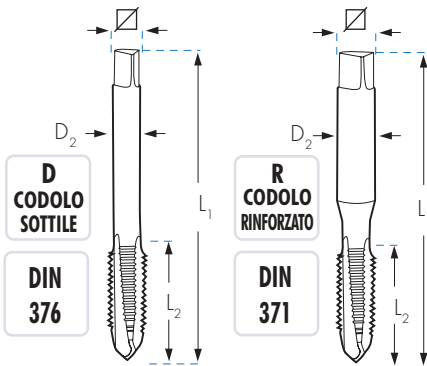

			M2RDU	M4RDU	M2RNI	M3RNI	M2RTIT	M3RTIT
QUALITÀ			★★★★	★★★★	★★★★	★★★★	★★★★	★★★★
MATERIALE			HSS V3	HSS V3	HSS PM	HSS PM	HSS PM	HSS PM
FINITURA			TiCN	TiCN	BRILLANTE	BRILLANTE	OX	OX
ANGOLO DELL'ELICA			FORMA B	41°	FORMA B	15°	FORMA B	15°
		$L_1 \times L_2 \times D_2 \times \square$ mm	€	€	€	€	€	€
M 3x0,50	2,50	R 56 x 11 x 3,5 x 2,7	42,97	44,02	79,86	81,60	59,28	65,43
M 4x0,70	3,30	R 63 x 13 x 4,5 x 3,4	42,97	44,30	81,60	83,80	61,14	65,43
M 5x0,80	4,20	R 70 x 16 x 6,0 x 4,9	44,41	45,28	84,47	86,46	62,68	69,70
M 6x1,00	5,00	R 80 x 17 x 6,0 x 4,9	45,65	46,63	85,14	87,54	62,68	70,67
M 8x1,25	6,80	R 90 x 20 x 8,0 x 6,2	63,75	66,46	96,21	98,77	72,42	81,60
M 10x1,50	8,50	R 100 x 22 x 10,0 x 8,0	82,62	84,77	114,32	117,81	89,70	98,31
CODOLO SOTTILE			M2DDU	M4DDU	M2DNI	M3DNI	M2DTIT	M3DTIT
M 12x1,75	10,20	D 110 x 24 x 9,0 x 7,0	111,71	120,62	147,03	162,58	112,57	122,17
M 14x2,00	12,00	D 110 x 26 x 11,0 x 9,0						
M 16x2,00	14,00	D 110 x 27 x 12,0 x 9,0	164,27	175,65				
M 18x2,50	15,50	D 125 x 30 x 14,0 x 11,0						
M 20x2,50	17,50	D 140 x 32 x 16,0 x 12,0	243,24	262,74				
M 22x2,50	19,50	D 140 x 32 x 18,0 x 14,5						
M 24x3,00	21,00	D 160 x 34 x 18,0 x 14,5	329,46	335,09				
M 27x3,00	24,00	D 160 x 36 x 20,0 x 16,0	423,26	443,68				
M 30x3,50	26,50	D 180 x 40 x 22,0 x 18,0	499,88	523,06				

MASCHI A MACCHINA PER ACCIAIO STRUTTURALI EXTRA DOLCE < DE 450 N/mm²

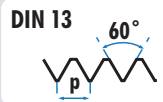

HSSCo
5%

OX

TOL
6H

APPLICAZIONI



ST52



Geometria di taglio specifica per materiali morbidi, non genera sovradimensionamento e si adatta perfettamente a questo tipo di materiali in cui i maschi convenzionali possono causare allargamenti durante la generazione del filo.

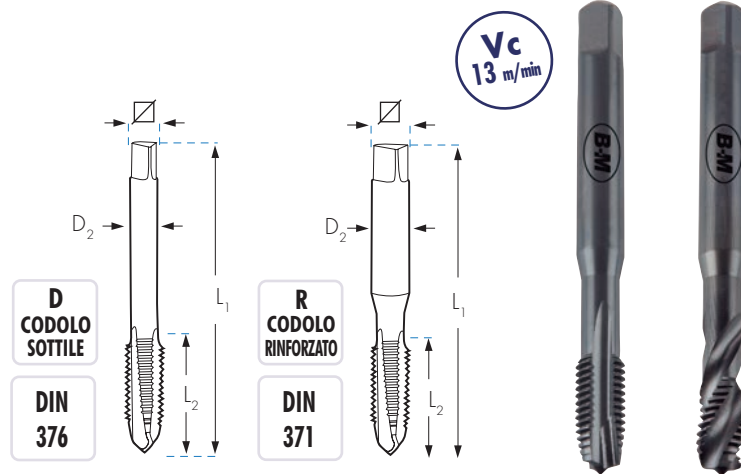

		L ₁ x L ₂ x D ₂ x mm	M2RSS	M4RSS
			FORMA B	
			€	€
M 3 x 0,50	2,50	R 56 x 11 x 3,5 x 2,7	14,19	18,67
M 4 x 0,70	3,30	R 63 x 13 x 4,5 x 3,4	14,98	18,69
M 5 x 0,80	4,20	R 70 x 16 x 6,0 x 4,9	15,08	17,91
M 6 x 1,00	5,00	R 80 x 17 x 6,0 x 4,9	15,97	19,67
M 8 x 1,25	6,80	R 90 x 20 x 8,0 x 6,2	18,47	22,76
M 10 x 1,50	8,50	R 100 x 22 x 10,0 x 8,0	22,74	26,95
CODOLO SOTTILE			M2DSS	M4DSS
M 12 x 1,75	10,20	D 110 x 24 x 9,0 x 7,0	25,80	31,24
M 14 x 2,00	12,00	D 110 x 26 x 11,0 x 9,0	36,84	43,34
M 16 x 2,00	14,00	D 110 x 27 x 12,0 x 9,0	41,10	50,02
M 18 x 2,50	15,50	D 125 x 30 x 14,0 x 11,0	58,55	70,48
M 20 x 2,50	17,50	D 140 x 32 x 16,0 x 12,0	68,54	75,23
M 22 x 2,50	19,50	D 140 x 32 x 18,0 x 14,5	82,27	91,70
M 24 x 3,00	21,00	D 160 x 34 x 18,0 x 14,5	96,92	111,45
M 27 x 3,00	24,00	D 160 x 36 x 20,0 x 16,0	122,58	137,13
M 30 x 3,50	26,50	D 180 x 40 x 22,0 x 18,0	157,49	175,74

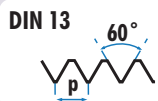
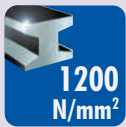
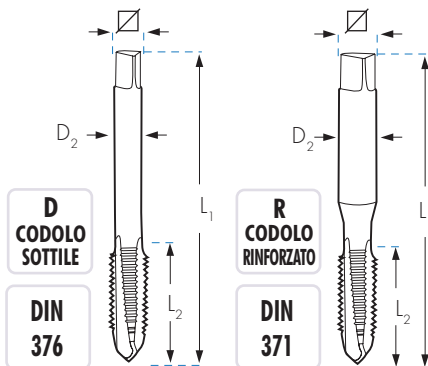
MASCHI A MACCHINA PER LAVORAZIONI SPECIALI HSS-V3

**HSS
V3**
**TOL
6H**
**MATERIALI
DURI**

**Vc
7 m/min**
**Vc
9 m/min**

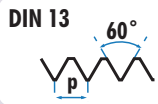
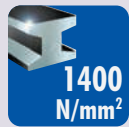
		M2RMD	M4RMD	M2RMDTX	M4RMDTX
QUALITÀ		★★★	★★★	★★★★	★★★★
MATERIALE		HSS V3	HSS V3	HSS V3	HSS V3
FINITURA		OX	OX	TINALOX	TINALOX
ANGOLO DELL'ELICA		FORMA B	35°	FORMA B	35°
		€	€	€	€
	$L_1 \times L_2 \times D_2 \times \square$ mm				
M 3x0,50	2,50 R 56 x 11 x 3,5 x 2,7	17,48	20,08	24,92	29,30
M 4x0,70	3,30 R 63 x 13 x 4,5 x 3,4	18,16	20,08	26,18	30,68
M 5x0,80	4,20 R 70 x 16 x 6,0 x 4,9	18,16	19,97	26,18	30,68
M 6x1,00	5,00 R 80 x 17 x 6,0 x 4,9	19,90	21,96	28,67	32,26
M 8x1,25	6,80 R 90 x 20 x 8,0 x 6,2	22,43	24,55	32,01	36,80
M 10x1,50	8,50 R 100 x 22 x 10,0 x 8,0	25,85	28,54	40,50	45,18
CODOLO SOTTILE		M2DMD	M4DMD	M2DMDTX	M4DMDTX
M 12x1,75	10,20 D 110 x 24 x 9,0 x 7,0	36,85	40,28	53,94	63,14
M 14x2,00	12,00 D 110 x 26 x 11,0 x 9,0	45,82	53,23	76,77	84,27
M 16x2,00	14,00 D 110 x 27 x 12,0 x 9,0	54,06	64,39	85,51	101,94
M 18x2,50	15,50 D 125 x 30 x 14,0 x 11,0	76,42	91,62	125,71	142,37
M 20x2,50	17,50 D 140 x 32 x 16,0 x 12,0	82,58	96,74	135,87	150,28

MASCHI A MACCHINA PER MATERIALI TEMPRATI (HARDOX 450/500)



TOL
6H

HSSE

HSS
PM

MD

MATERIALI
MOLTO
DURI

48
HRc

48-62
HRc

Vc
5 m/min

MD

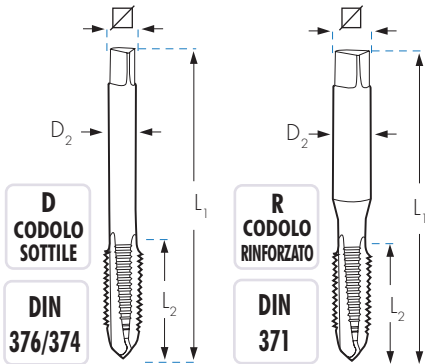

MATERIALE	M2RC		M3RC		M2HRC		M4HRC		M1RCM		M1RHMC	
	HSSE	HSSE	HSS PM	HSS PM	TINALOX	TINALOX	TiCN	TiCN	MD	TiCN	MD	
FINITURA	TiAIN		TiAIN		TINALOX		TINALOX		TiCN		TiCN	
FORMA	FORMA B		FORMA B 15°		FORMA B		FORMA B 35°		FORMA C		FORMA C	
	€	€	€	€	€	€	€	€	€	€	€	
M 2 x 0,40	1,60				43,54	47,61	1,70		1,70			
M 3 x 0,50	2,50		28,11	29,91	39,72	44,48	2,60	45,03	2,60	116,58		
M 4 x 0,70	3,30		28,17	31,85	41,25	46,21	3,40	39,61	3,40	116,58		
M 5 x 0,80	4,20		28,43	31,12	41,65	46,64	4,30	44,26	4,30	116,58		
M 6 x 1,00	5,00		30,74	34,46	43,44	48,65	5,10	56,67	5,10	145,72		
M 8 x 1,25	6,80		35,51	40,52	54,00	60,48	6,90	62,86	6,90	164,01		
M 10 x 1,50	8,50		42,51	50,20	64,63	67,86	8,60	81,49	8,60	251,65		
CODOLO SOTTILE			M2DC	M3DC	M2HDC	M4HDC	M1RCM		M1DHMC			
M 12 x 1,75	10,20	D 110 x 24 x 9,0 x 7,0	63,56	75,45	98,66	107,54	10,40	107,81 *	10,40	394,13		
M 14 x 2,00	12,00	D 110 x 26 x 11,0 x 9,0	85,82	100,38	116,99	127,52	12,10	136,30 *	12,10	507,53		
M 16 x 2,00	14,00	D 110 x 27 x 12,0 x 9,0	96,84	115,30	130,09	141,80	14,10	145,80 *	16,10	662,72		
M 18 x 2,50	15,50	D 125 x 30 x 14,0 x 11,0	122,62	133,52	137,60	149,98			15,75	809,65		
M 20 x 2,50	17,50	D 140 x 32 x 16,0 x 12,0	148,50	154,56	190,16	207,28			17,75	1.280,72		
M 22 x 2,50	19,50	D 140 x 32 x 18,0 x 14,5	210,36	219,36								
M 24 x 3,00	21,00	D 160 x 34 x 18,0 x 14,5	215,36	225,36	257,08	280,21						
M 27 x 3,00	24,00	D 160 x 36 x 20,0 x 16,0	235,36	242,36								
M 30 x 3,50	26,50	D 180 x 40 x 22,0 x 18,0	241,25	255,36								

* Codolo Rinforzato: M12 - Ø 12 x 9
M14 - Ø 14 x 11
M16 - Ø 16 x 12





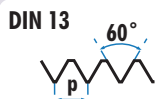
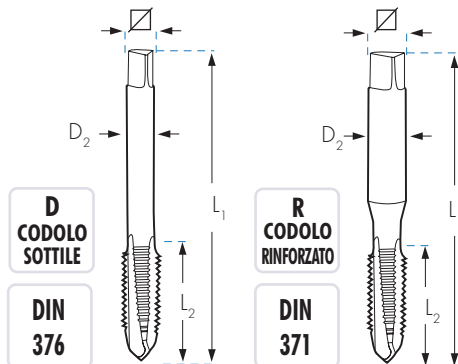

- Lubrificazione: **CUT MAGIC XTHICK**
- Si raccomanda di filettare il pezzo sulla stessa attrezzatura utilizzata per la foratura precedente e nella stessa posizione, per garantire co-assialità tra il maschio e il preforo.

Ref. ACXT00250

HRc	Vc (m/min)
48 Hrc	8 m/min
56 Hrc	6 m/min
62 Hrc	3 m/min

MASCHI A MACCHINA QUALSIASI TERRENO
**QUALSIASI
TERRENO**

**HSSCo
5%**
TiN
**TOL
6H**
APPLICAZIONI
**1200
N/mm²**
Al
GHISA
Ti
INOX
**Vc
13
m/min**

		L ₁ x L ₂ x D ₂ x  mm	M2RD	M4RD
			FORMA B €	 €
M 3 x 0,50	2,50	R 56 x 11 x 3,5 x 2,7	20,87	25,51
M 4 x 0,70	3,30	R 63 x 13 x 4,5 x 3,4	22,11	25,51
M 5 x 0,80	4,20	R 70 x 16 x 6,0 x 4,9	25,63	29,14
M 6 x 1,00	5,00	R 80 x 17 x 6,0 x 4,9	26,50	30,24
M 8 x 1,25	6,80	R 90 x 20 x 8,0 x 6,2	31,06	34,51
M 10 x 1,50	8,50	R 100 x 22 x 10,0 x 8,0	35,84	40,86
CODOLO SOTTILE			M2DD	M4DD
M 12 x 1,75	10,20	D 110 x 24 x 9,0 x 7,0	45,16	53,75
M 14 x 2,00	12,00	D 110 x 26 x 11,0 x 9,0	58,97	64,81
M 16 x 2,00	14,00	D 110 x 27 x 12,0 x 9,0	66,08	71,52
M 18 x 2,50	15,50	D 125 x 30 x 14,0 x 11,0	90,16	105,89
M 20 x 2,50	17,50	D 140 x 32 x 16,0 x 12,0	105,17	109,13

MASCHI A MACCHINA PER LAVORAZIONI SPECIALI HSSCo

AI
GHISA
OTTONE
DIN 13 60°
HSSCo 5%
MD
TOL 6H

Vc
18 m/min

Vc
11 m/min

Vc
21 m/min

Vc
16 m/min

Vc
19 m/min

Vc
19 m/min

D
CODOLO SOTTILE

DIN 376

R
CODOLO RINFORZATO

DIN 371

		M5R	M6R	MTRFM	MHMTR	M1RL	M1RLCRN	
APPLICAZIONE		AI	AI	GHISA	GHISA	OTTONE	OTTONE	
MATERIALE		HSSCo 5%	HSSCo 5%	HSSCo 5%	MD	HSSCo 5%	HSSCo 5%	
FINITURA		BRILLANTE	BRILLANTE	OX	BRILLANTE	BRILLANTE	CrN	
FORMA		DENTI ALTERNATI	2 CANALI	FORMA C	FORMA C	FORMA C	FORMA C	
		L ₁ x L ₂ x D ₂ x		€	€	€	€	
M 3x0,50	2,50	R 56 x 11 x 3,5 x 2,7	16,46	19,01	14,13	78,82	16,77	19,04
M 4x0,70	3,30	R 63 x 13 x 4,5 x 3,4	16,44	19,01	14,62	78,82	17,81	21,00
M 5x0,80	4,20	R 70 x 16 x 6,0 x 4,9	17,16	19,39	14,62	78,82	17,81	21,06
M 6x1,00	5,00	R 80 x 17 x 6,0 x 4,9	17,11	20,97	16,59	89,89	19,50	23,01
M 8x1,25	6,80	R 90 x 20 x 8,0 x 6,2	20,78	25,13	18,59	100,38	22,24	27,98
M 10x1,50	8,50	R 100 x 22 x 10,0 x 8,0	24,69	29,73	21,25	125,79	26,75	34,05
CODOLO SOTTILE		M5D	M6D	M1DFM	MHM1D	M1DL	M1DLCRN	
M 12x1,75	10,20	D 110 x 24 x 9,0 x 7,0	31,61	38,44	27,24	178,83	31,81	41,90
M 14x2,00	12,00	D 110 x 26 x 11,0 x 9,0	40,83	48,66	44,76	278,62	39,05	51,09
M 16x2,00	14,00	D 110 x 27 x 12,0 x 9,0	45,37	63,69	52,68	331,47	44,92	57,12
M 18x2,50	15,50	D 125 x 30 x 14,0 x 11,0			73,69	406,31	58,94	72,35
M 20x2,50	17,50	D 140 x 32 x 16,0 x 12,0			73,96	492,02	66,15	80,55



- Lubrificazione: **CUT MAGIC ALUMINIO**
- Si raccomanda l'applicazione dell'olio da taglio CUT MAGIC ALUMINIO per ottimizzare il processo di filettatura in alluminio e le sue ghise.

Ref. ACAL00250

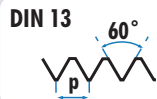
MASCHI PER FILETTARE A MACCHINA PER LAMINAZIONE

HSSCo
5%
HSSCo
8%
TOL
6HX
APPLICAZIONI

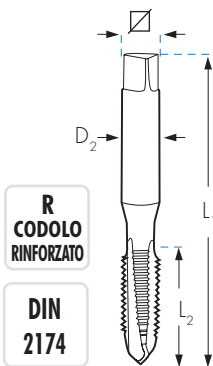
Al
GHISA

INOX
Plus

APPLICAZIONE	MATERIALE	FINITURA	FORMA	M07R	M07RT	M07RCR	M07RCCR	M09RCCR	M07RXTCR
				HSSCo 5%	HSSCo 5%	HSSCo 5%	HSSCo 5%	HSSCo 8%	HSSCo 5%
				OX	TiN	OX	TiCN	TiCN	TiN
			$L_1 \times L_2 \times D_2 \times \square$ mm	€	€	€	€	€	€
M 3x0,50	2,75	R	56 x 11 x 3,5 x 2,7	24,97	35,11	32,34	49,26	111,76	
M 3,5x0,60	3,20	R	56 x 11 x 3,5 x 2,7	26,25	37,29	35,43	52,12		
M 4x0,70	3,65	R	63 x 13 x 4,5 x 3,4	27,33	36,63	32,01	51,37	113,17	83,35
M 5x0,80	4,60	R	70 x 16 x 6,0 x 4,9	27,33	36,63	34,28	51,37	114,68	89,95
M 6x1,00	5,50	R	80 x 17 x 6,0 x 4,9	27,92	38,70	34,89	54,29	116,50	89,95
M 8x1,25	7,40	R	90 x 20 x 8,0 x 6,2	33,64	51,08	40,69	71,66	129,23	107,65
M 10x1,50	9,30	R	100 x 22 x 10,0 x 8,0	39,49	57,28	47,96	78,88	154,30	131,43

CODOLO SOTTILE				M07D	M07DT	M07DCR	M07DCCR	M09DCCR	M07DXTCR
M 12x1,75	11,20	D	110 x 24 x 9,0 x 7,0	48,46	72,13	48,46	100,61	182,65	171,15
M 14x2,00	13,05	D	110 x 26 x 11,0 x 9,0	87,38	118,30	87,38	161,30	227,30	246,20
M 16x2,00	15,05	D	110 x 27 x 12,0 x 9,0	102,59	133,24	102,59	189,28	312,64	250,47
M 18x2,50	16,80	D	125 x 30 x 14,0 x 11,0	124,77	153,41	124,77	201,74	370,43	
M 20x2,50	18,80	D	140 x 32 x 16,0 x 12,0	164,41	232,24	164,41	330,85	410,11	

MASCHI A MACCHINA HSSCo A TOLLERANZA SPECIALE E SOVRAMISURA



		M2R4H	M4R4H	M2R6G	M4R6G	M2R7G	M4R7G	M2R+0,1	M4R+0,1	M2R+0,2	M4R+0,2
TOLLERANZA		TOL 4H	TOL 4H	TOL 6G	TOL 6G	TOL 7G	TOL 7G	TOL 6H (+0,1)	TOL 6H (+0,1)	TOL 6H (+0,2)	TOL 6H (+0,2)
MATERIALE		HSSCo 5%	HSSCo 5%	HSSCo 5%	HSSCo 5%	HSSCo 5%	HSSCo 5%	HSSCo 5%	HSSCo 5%	HSSCo 5%	HSSCo 5%
FINITURA		BRILLANTE	BRILLANTE	BRILLANTE	BRILLANTE	BRILLANTE	BRILLANTE	BRILLANTE	BRILLANTE	BRILLANTE	BRILLANTE
FORMA		FORMA B	FORMA B 35°	FORMA B	FORMA B 35°	FORMA B	FORMA B 35°	FORMA B	FORMA B 35°	FORMA B	FORMA B 35°
	$L_1 \times L_2 \times D_2 \times \square$ mm	€	€	€	€	€	€	€	€	€	€
M 3x0,50	2,50 R 56x11x 3,5x 2,7	19,53	24,16	13,79	16,82	16,59	20,51	16,37	20,77	25,24	31,25
M 4x0,70	3,30 R 63x13x 4,5x 3,4	19,98	24,16	13,79	16,82	16,97	20,51	16,37	20,77	25,82	27,57
M 5x0,80	4,20 R 70x16x 6,0x 4,9	19,98	23,15	14,50	17,55	16,97	19,65	16,37	19,90	25,82	29,93
M 6x1,00	5,00 R 80x17x 6,0x 4,9	21,96	25,41	14,45	17,67	18,66	21,56	16,43	21,83	28,38	32,84
M 8x1,00	7,00 D 90x20x 6,0x 4,9			34,12	37,75						
M 8x1,25	6,75 R 90x20x 8,0x 6,2	24,59	29,00	18,37	21,78	20,87	24,61	20,14	24,92	28,07	37,49
M 10x1,00	9,00 D 90x16x 7,0x 5,5			40,29	46,89						
M 10x1,50	8,50 R 100x22x 10,0x 8,0	30,23	34,41	21,78	24,93	25,67	32,46	24,77	29,55	34,51	39,24
CODOLO SOTTILE		M2D4H	M4D4H	M2D6G	M4D6G	M2D7G	M4D7G	M2D+0,1	M4D+0,1	M2D+0,2	M4D+0,2
M 12x1,50	10,50 D 100x22x 9,0x 7,0			71,29	84,51						
M 12x1,75	10,20 D 110x24x 9,0x 7,0	39,00	46,30	25,45	27,59	31,27	37,12	30,57	46,78	44,46	52,81
M 14x2,00	12,00 D 110x26x 11,0x 9,0			37,08	39,71			66,23	78,96	82,18	95,26
M 16x2,00	14,00 D 110x27x 12,0x 9,0			41,41	42,14			77,90	95,42	85,33	101,60
M 18x2,50	15,50 D 125x30x 14,0x 11,0			57,61	61,79			113,49	128,49	136,93	144,19
M 20x2,50	17,50 D 140x32x 16,0x 12,0			70,97	81,41			122,64	136,73	147,95	155,36

4H.-Per filettature molto precise. Regolazione più esatta.

6G.- Per filettature con rivestimenti. Spessore tra 20 – 40 μ

7G.-Per filettature con rivestimenti. Spessore tra 20 – 50 μ

6H. (+0,1)- Per ottenere filettature con sovramisure o per compensare deformazioni da trattamenti termici.

6H. (+0,2)- Per ottenere filettature con sovramisure o per compensare deformazioni da trattamenti termici.

MASCHI A MACCHINA EXTRA LUNGI HSSCo
**FORMA
B**

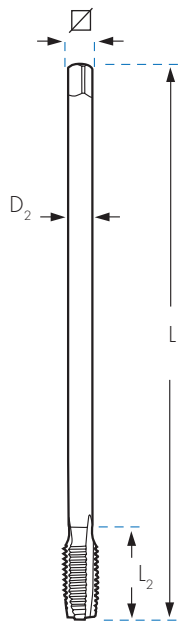
**HSSCo
5%**
BRILLANTE
**TOL
6H**
**R
CODOLO
RINFORZATO**
**DIN
371**
**D
CODOLO
SOTTILE**
**DIN
376**

				M2L
			$L_1 \times L_2 \times D_2 \times \square$ mm	FORMA B €
M	3x0,50	2,50	R 100 x 10 x 3,5 x 2,7	17,73
M	4x0,70	3,30	R 120 x 12 x 4,5 x 3,4	18,13
M	5x0,80	4,20	R 140 x 14 x 6,0 x 4,9	21,33
M	6x1,00	5,00	R 160 x 16 x 6,0 x 4,9	21,36
M	7x1,00	6,00	R 160 x 17 x 7,0 x 5,5	25,90
M	8x1,25	6,80	R 180 x 18 x 8,0 x 6,2	26,03

				M2L-D
				€
CODOLO SOTTILE				
M	6x1,00	5,00	D 160 x 16 x 4,5 x 3,4	23,70
M	8x1,25	6,80	D 180 x 18 x 6,2 x 5,0	27,80
M	10x1,50	8,50	D 200 x 20 x 7,0 x 5,5	29,95
M	12x1,75	10,20	D 220 x 22 x 8,5 x 6,5	33,90
M	14x2,00	12,00	D 220 x 25 x 10,5 x 8,0	62,88
M	16x2,00	14,00	D 220 x 28 x 12,5 x 10,0	73,98
M	18x2,50	15,50	D 250 x 32 x 14,0 x 11,0	134,59
M	20x2,50	17,50	D 250 x 32 x 16,0 x 12,0	145,49
M	22x2,50	19,50	D 250 x 35 x 18,0 x 14,5	235,36
M	24x3,00	21,00	D 250 x 38 x 18,0 x 14,5	296,36

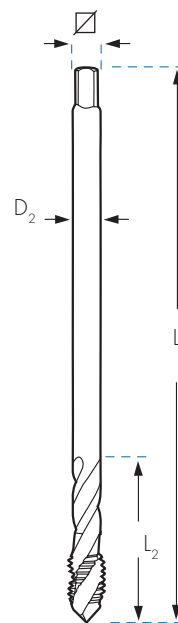
**HSSCo
5%**
BRILLANTE
**TOL
6H**
**R
CODOLO
RINFORZATO**
**DIN
371**
**D
CODOLO
SOTTILE**
**DIN
376**

				M4L
			$L_1 \times L_2 \times D_2 \times \square$ mm	35° €
M	3x0,50	2,50	R 100 x 10 x 3,5 x 2,7	21,02
M	4x0,70	3,30	R 120 x 12 x 4,5 x 3,4	21,94
M	5x0,80	4,20	R 140 x 14 x 6,0 x 4,9	24,09
M	6x1,00	5,00	R 160 x 16 x 6,0 x 4,9	25,47
M	7x1,00	6,00	R 160 x 17 x 7,0 x 5,5	30,00
M	8x1,25	6,80	R 180 x 18 x 8,0 x 6,2	29,78

				M4L-D
				€
CODOLO SOTTILE				
M	6x1,00	5,00	D 160 x 16 x 4,5 x 3,4	27,45
M	8x1,25	6,80	D 180 x 18 x 6,2 x 5,0	32,12
M	10x1,50	8,50	D 200 x 20 x 7,0 x 5,5	36,20
M	12x1,75	10,20	D 220 x 22 x 8,5 x 6,5	37,63
M	14x2,00	12,00	D 220 x 25 x 10,5 x 8,0	70,47
M	16x2,00	14,00	D 220 x 28 x 12,5 x 10,0	102,12
M	18x2,50	15,50	D 250 x 32 x 14,0 x 11,0	152,41
M	20x2,50	17,50	D 250 x 32 x 16,0 x 12,0	162,19
M	22x2,50	19,50	D 250 x 35 x 18,0 x 14,5	265,36
M	24x3,00	21,00	D 250 x 38 x 18,0 x 14,5	311,25

MASCHIO A MACCHINA PER DADI FILETTATURA METRICA DIN 357



HSSCo
5%

BRILLANTE

TOL
6H

DIN
357

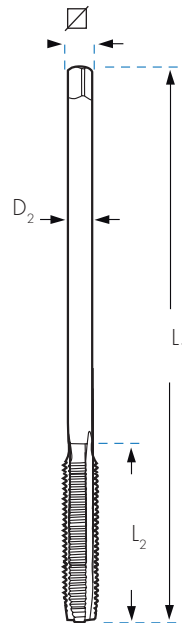

			L ₁ x L ₂ x D ₂ x \square mm	MTU
				FORMA A
				€
M 3x0,50**	2,50	D	70 x 22 x 2,2	22,86
M 4x0,70	3,30	D	90 x 25 x 2,8 x 2,1	22,86
M 5x0,80	4,20	D	100 x 28 x 3,5 x 2,7	22,86
M 6x1,00	5,00	D	110 x 32 x 4,5 x 3,4	22,86
M 8x1,25	6,80	D	125 x 40 x 6,0 x 4,9	27,88
M 10x1,50	8,50	D	140 x 45 x 7,0 x 5,5	30,00
M 12x1,75	10,20	D	180 x 50 x 9,0 x 7,0	49,27
M 14x2,00	12,00	D	200 x 56 x 11,0 x 9,0	57,39
M 16x2,00	14,00	D	200 x 63 x 12,0 x 9,0	71,07
M 18x2,50	15,50	D	220 x 63 x 14,0 x 11,0	95,61
M 20x2,50	17,50	D	250 x 70 x 16,0 x 12,0	121,20*
M 22x2,50	19,50	D	280 x 80 x 18,0 x 14,5	148,70*
M 24x3,00	21,00	D	280 x 80 x 18,0 x 14,5	202,31*

** Codolo cilindrico

*Fino ad esaurimento scorte

Maschi e Filiere

Rosa

BLUE-MASTER
by CELESA

CONSULTI LA NOSTRA AMPIA GAMMA DI UTENSILI
PER LA RIPARAZIONE DEI FILETTI Pag. 659



INSERTI
STANDARD

INSERTI CON SEGLIANTI
ANAEROBICO

INSERTI
AUTOFILETTANTI

INSERTI
DI SICUREZZA

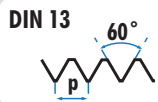
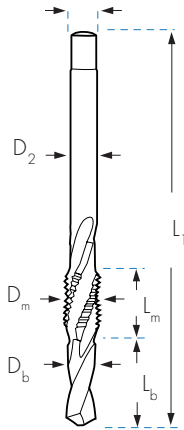
PUNTA-MASCHIO HSSCo

HSSCo
5%
BRILLANTE
TOL
6H
R
CODOLO
RINFORZATO
DIN
371
D
CODOLO
SOTTILE
DIN
376

		L _b mm	L _m mm	L ₁ mm	D _b mm	D _m mm	D ₂ mm	∅ mm	M8M €
M 3x0,50	R	9,0	12,5	62,0	2,50	3,0	3,5	2,7	30,95
M 4x0,70	R	10,0	16,0	66,0	3,30	4,0	4,5	3,4	30,95
M 5x0,80	R	12,5	18,0	75,5	4,20	5,0	6,0	4,9	33,40
M 6x1,00	R	14,0	20,0	81,0	5,00	6,0	6,0	4,9	36,90
M 8x1,00	R	20,0	14,0	91,0	7,00	8,0	6,0	4,9	46,42
M 8x1,25	R	20,0	14,0	91,0	6,75	8,0	8,0	6,2	47,86

CODOLO SOTTILE

M 8x1,25	D	20,0	14,0	91,0	6,75	8,0	6,0	4,9	42,98
M 10x1,00	D	20,0	15,0	95,0	9,00	10,0	7,0	5,5	57,64
M 10x1,50	D	25,0	18,0	105,0	8,50	10,0	7,0	5,5	46,97
M 12x1,50	D	24,0	18,0	110,0	10,50	12,0	9,0	7,0	62,39
M 12x1,75	D	28,0	20,0	118,0	10,20	12,0	9,0	7,0	55,80
M 14x1,50	D	28,0	20,0	118,0	12,50	14,0	11,0	9,0	105,65
M 14x2,00	D	28,0	22,0	130,0	12,00	14,0	11,0	9,0	102,11
M 16x2,00	D	36,0	24,0	139,0	14,00	16,0	12,0	9,0	165,36
M 18x2,50	D	40,0	26,0	151,0	15,50	18,0	14,0	11,0	195,86
M 20x2,50	D	45,0	30,0	168,0	17,50	20,0	16,0	12,0	331,04

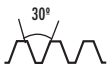
 NOTA: Non utilizzare i Punta-Maschi in fori ciechi o passanti più profondi di L_b.

MASCHIO A MACCHINA PER FILETTATURA TRAPEZOIDALE HSS

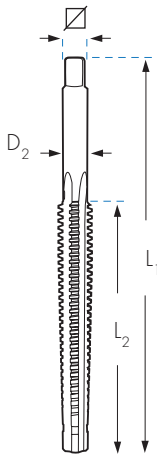
HSS
BRILLANTE

DIN
103
TOL
7H

		∅	L ₁ x L ₂ x D ₂ x ∅ mm	MRTM €
Tr	14 x 3	11,25	160 x 105 x 10,5 x 8,0	380,60
Tr	16 x 4	12,25	205 x 110 x 11,5 x 9,0	413,45
Tr	18 x 4	14,25	215 x 120 x 13,0 x 10,0	423,75
Tr	20 x 4	16,25	230 x 130 x 15,0 x 12,0	443,97
Tr	22 x 5	17,25	270 x 165 x 16,0 x 12,0	576,39
Tr	24 x 5	19,25	280 x 165 x 18,0 x 14,5	662,87
Tr	26 x 5	21,25	290 x 170 x 20,0 x 16,0	685,85
Tr	28 x 5	23,25	300 x 180 x 22,0 x 18,0	766,28
Tr	30 x 6	24,25	345 x 200 x 23,0 x 18,0	906,37

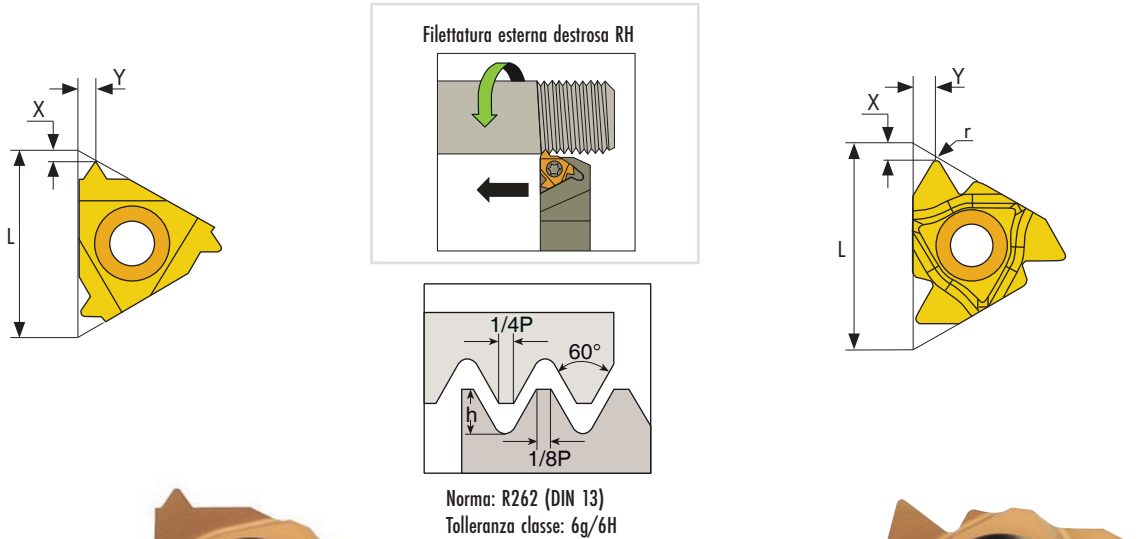
PLACCHETTE PER FILETTATURA ESTERNA



Profilo totale

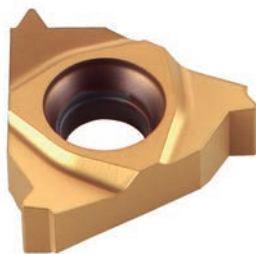
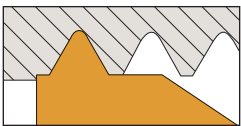

Profilo parziale

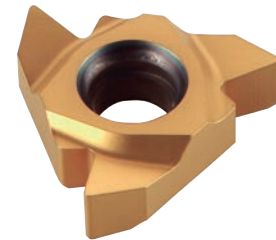
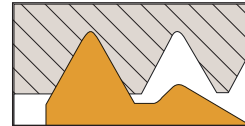

Filettare il profilo completo, terminando il diametro esterno della filettatura. Utilizzeremo una placchetta differente per ogni passo.

Non terminare il diametro esterno della filettatura. La stessa placchetta può essere utilizzata per una gamma di differenti passi aventi lo stesso angolo di filettatura.

PROFILO TOTALE 60°

FILETTATURA ESTERNA	L	PASSO	h	X	Y	€
PRE-16-075	16	0,75	0,46	0,6	0,6	25,66*
PRE-16-100		1,00	0,61	0,7	0,7	25,66*
PRE-16-125		1,25	0,77	0,8	0,9	25,66*
PRE-16-150		1,50	0,92	0,8	1	25,66*
PRE-16-175		1,75	1,07	0,9	1,2	25,66*
PRE-16-200		2,00	1,23	1	1,3	25,66*
PRE-16-250		2,50	1,53	1,1	1,5	25,66*
PRE-16-300		3,00	1,84	1,2	1,6	25,66*

*Fino ad esaurimento scorte.

PROFILO PARZIALE 60°

FILETTATURA ESTERNA	L	INTERVALLI METRICI	INTERVALLI POLLICI	r	X	Y	€
PPRE-16-150	16	0,50-1,50	48 - 16	0,05	0,80	0,90	25,66*
PPRE-16-300		1,75-3,00	14 - 8	0,27	1,20	1,70	25,66*

*Fino ad esaurimento scorte.

PORTAUTENSILI DA FILETTATURA ESTERNA

FILETTATURA ESTERNA	H1=H=B=F	L1	L2	€
PEXT-25-16	25	153	30	187,65*

*Fino ad esaurimento scorte.

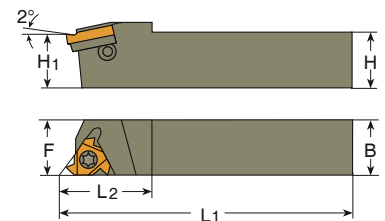

	Vc		Vc
ACCIAIO DOLCE 70 kg/mm ²	25 m / min	ALLUMINIO	50 m / min
ACCIAIO TRATTATO 120 kg/mm ²	13 m / min	TITANIO	18 m / min
INOX	11 m / min	GHISA	25 m / min
		OTTONE	50 m / min

FORMULA MATEMATICA PER RICAIVARE LA VELOCITÀ DI GIRO DEL PEZZO (RPM)

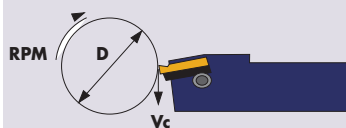

RPM: Rotazioni x minuto
Vc: Velocità di taglio (m/mm)
D: Diametro pezzo (mm)

$$RPM = \frac{1000 \times Vc}{\pi \times D}$$

le RPM si ricavano in funzione di Vc e D

PLACCHETTE PER FILETTATURA INTERNA

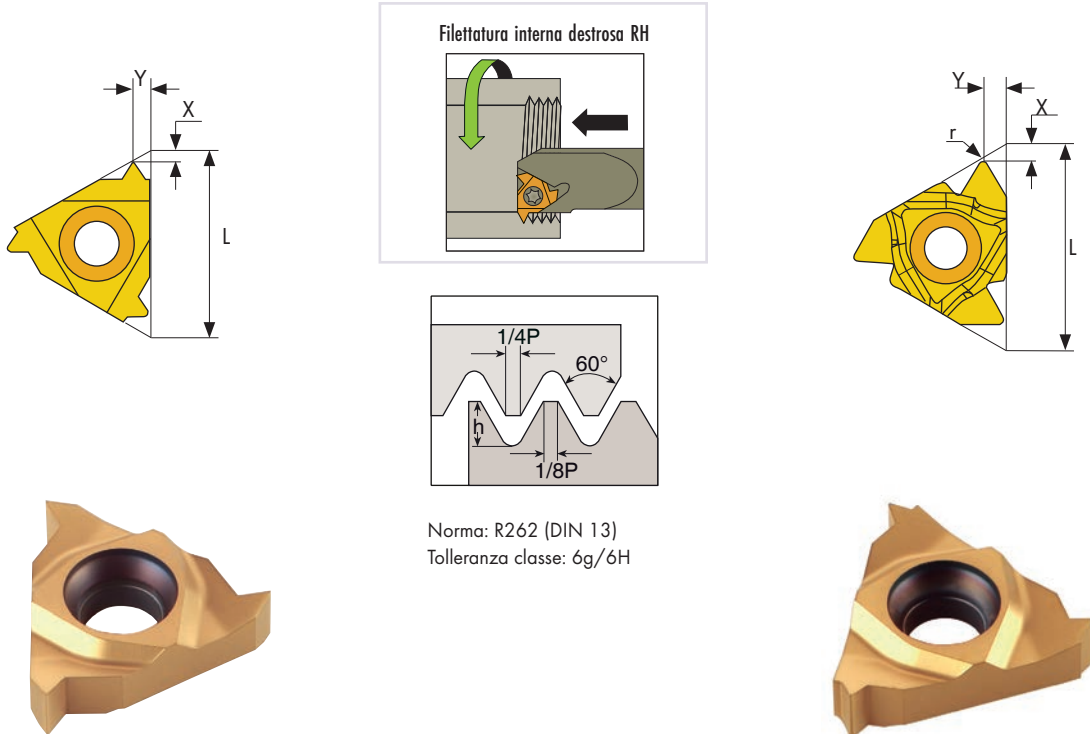

Norma: R262 (DIN 13)
Tolleranza classe: 6g/6H

PROFILO TOTALE 60°

FILETTATURA INTERNA	L	PASSO	h	X	Y	€
PRI-16-075	16	0,75	0,43	0,6	0,6	25,66*
PRI-16-100		1,00	0,58	0,6	0,7	25,66*
PRI-16-125		1,25	0,72	0,8	0,9	25,66*
PRI-16-150		1,50	0,87	0,8	1,0	25,66*
PRI-16-175		1,75	1,01	0,9	1,2	25,66*
PRI-16-200		2,00	1,15	1,0	1,3	25,66*
PRI-16-250		2,50	1,44	1,1	1,5	25,66*
PRI-16-300		3,00	1,73	1,1	1,5	25,66*

*Fino ad esaurimento scorte.

PROFILO PARZIALE 60°

FILETTATURA INTERNA	L	INTERVALLI METRICI	INTERVALLO POLLICI	r	X	Y	€
PPRI-16-150	16	0,50-1,50	48 - 16	0,05	0,80	0,90	25,66*
PPRI-16-300		1,75-3,00	14 - 8	0,16	1,20	1,70	25,66*

*Fino ad esaurimento scorte.

PORTAUTENSILI DA FILETTATURA INTERNA

FILETTATURA INTERNA	L	L1	D	D1	A	Ø Min. foro	€
PINT-20-16	180	40	20	20	18	24	184,96*
PINT-25-16	200	45	25	24,6	22,6	29	226,14*

*Fino ad esaurimento scorte.

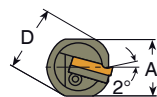
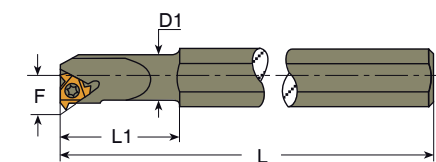

SET DI MASCHI A MACCHINA HSSCo IN SCATOLE METALLICHE

**USO
GENERALE**

**HSSCo
5%**



Ref. JM6



Ref. JM2





Ref. JM8



Ref. JM4

CONTENUTO

	FORMA C	FORMA B	 15°	 35°	 HSS	HSSCo 5% €
JM5	M3 - M4 - M5 - M6 M8 - M10 - M12	-	-	-	-	107,83
JM1	M3 - M4 - M5 - M6 M8 - M10 - M12	-	-	-	2.5 / 3.3 / 4.2 / 5.0 6.8 / 8.5 / 10.2 mm	132,63
JM6	-	M3 - M4 - M5 - M6 M8 - M10 - M12	-	-	-	114,26
JM2	-	M3 - M4 - M5 - M6 M8 - M10 - M12	-	-	2.5 / 3.3 / 4.2 / 5.0 6.8 / 8.5 / 10.2 mm	139,05
JM7	-	-	M3 - M4 - M5 - M6 M8 - M10 - M12	-	-	146,59
JM3	-	-	M3 - M4 - M5 - M6 M8 - M10 - M12	-	2.5 / 3.3 / 4.2 / 5.0 6.8 / 8.5 / 10.2 mm	171,39
JM8	-	-	-	M3 - M4 - M5 - M6 M8 - M10 - M12	-	135,07
JM4	-	-	-	M3 - M4 - M5 - M6 M8 - M10 - M12	2.5 / 3.3 / 4.2 / 5.0 6.8 / 8.5 / 10.2 mm	159,87

ASSORTIMENTI DI MASCHI A MACCHINA IN SCATOLE METALLICHE

Plus



Ref. JMPT2

CONTENUTO

	FORMA B	BRILLANTE	 35°	BRILLANTE	 HSSCo 5%	HSS PM €		TiN €
JMP6	M3 - M4 - M5 - M6 M8 - M10 - M12		-		-	129,31	JMPT6	187,28
JMP2	M3 - M4 - M5 - M6 M8 - M10 - M12		-		2.5 / 3.3 / 4.2 / 5.0 6.8 / 8.5 / 10.2 mm	175,05	JMPT2	233,01
JMP8	-		M3 - M4 - M5 - M6 M8 - M10 - M12		-	150,34	JMPT8	205,25
JMP4	-		M3 - M4 - M5 - M6 M8 - M10 - M12		2.5 / 3.3 / 4.2 / 5.0 6.8 / 8.5 / 10.2 mm	196,07	JMPT4	250,98

INOX

CONTENUTO

	FORMA B	OX	 35°	OX	 HSSCo 5%	HSS PM €		TiN €
JMX6	M3 - M4 - M5 - M6 M8 - M10 - M12		-		-	145,67	JMXT6	177,26
JMX2	M3 - M4 - M5 - M6 M8 - M10 - M12		-		2.5 / 3.3 / 4.2 / 5.0 6.8 / 8.5 / 10.2 mm	191,39	JMXT2	222,99
JMX8	-		M3 - M4 - M5 - M6 M8 - M10 - M12		-	178,10	JMXT8	205,40
JMX4	-		M3 - M4 - M5 - M6 M8 - M10 - M12		2.5 / 3.3 / 4.2 / 5.0 6.8 / 8.5 / 10.2 mm	223,84	JMXT4	251,12

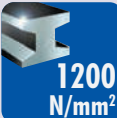
 1200
N/mm²

CONTENUTO

	FORMA B	OX	 35°	OX	 HSSCo 5%	HSS V3 €		TINALOX €
JMMD6	M3 - M4 - M5 - M6 M8 - M10 - M12		-		-	161,98	JMMDT6	231,69
JMMD2	M3 - M4 - M5 - M6 M8 - M10 - M12		-		2.5 / 3.3 / 4.2 / 5.0 6.8 / 8.5 / 10.2 mm	207,71	JMMDT2	277,42
JMMD8	-		M3 - M4 - M5 - M6 M8 - M10 - M12		-	177,72	JMMDT8	265,39
JMMD4	-		M3 - M4 - M5 - M6 M8 - M10 - M12		2.5 / 3.3 / 4.2 / 5.0 6.8 / 8.5 / 10.2 mm	223,46	JMMDT4	311,13

ASSORTIMENTI DI MASCHI A MACCHINA IN SCATOLE METALLICHE

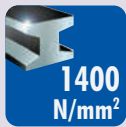

Ref. JMC2

CONTENUTO

	FORMA B	TiCN	15°	TiCN	HSSCo 5%	HSS-PM €
JMC6	M3 - M4 - M5 - M6 M8 - M10 - M12		-		-	265,61
JMC2	M3 - M4 - M5 - M6 M8 - M10 - M12		-		2.5 / 3.3 / 4.2 / 5.0 6.8 / 8.5 / 10.2 mm	311,34
JMC8	-		M3 - M4 - M5 - M6 M8 - M10 - M12		-	299,80
JMC4	-		M3 - M4 - M5 - M6 M8 - M10 - M12		2.5 / 3.3 / 4.2 / 5.0 6.8 / 8.5 / 10.2 mm	345,54

QUALSIASI TERRENO

CONTENUTO

	FORMA B	TiN	35°	TiN	HSSCo 5%	HSSCo 5% €
JMD6	M3 - M4 - M5 - M6 M8 - M10 - M12		-		-	219,93
JMD2	M3 - M4 - M5 - M6 M8 - M10 - M12		-		2.5 / 3.3 / 4.2 / 5.0 6.8 / 8.5 / 10.2 mm	265,65
JMD8	-		M3 - M4 - M5 - M6 M8 - M10 - M12		-	251,03
JMD4	-		M3 - M4 - M5 - M6 M8 - M10 - M12		2.5 / 3.3 / 4.2 / 5.0 6.8 / 8.5 / 10.2 mm	296,77

AI

CONTENUTO

	DENTI ALTERNATI	BRILLANTE	2 CANALI	BRILLANTE	HSS	HSSCo 5% €
JMAL6	M3 - M4 - M5 - M6 M8 - M10 - M12		-		-	155,16
JMAL2	M3 - M4 - M5 - M6 M8 - M10 - M12		-		2.5 / 3.3 / 4.2 / 5.0 6.8 / 8.5 / 10.2 mm	180,65
JMAL8	-		M3 - M4 - M5 - M6 M8 - M10 - M12		-	182,47
JMAL4	-		M3 - M4 - M5 - M6 M8 - M10 - M12		2.5 / 3.3 / 4.2 / 5.0 6.8 / 8.5 / 10.2 mm	207,28

MASCHI A MACCHINA IN ASTUCCI
**USO
GENERALE**
CONTENUTO

	FORMA B	BRILLANTE	 35°	BRILLANTE	HSSCo 5% €
PT01	M4 - M5 - M6 M8 - M10		M4 - M5 - M6 M8 - M10		146,73



Ref. PT01

Plus
CONTENUTO

	FORMA B	BRILLANTE	 35°	BRILLANTE	HSS PM €	TiN €
PT02	M4 - M5 - M6 M8 - M10		M4 - M5 - M6 M8 - M10		161,46	PT03 237,07



Ref. PT03

INOX
CONTENUTO

	FORMA B	OX	 35°	OX	HSS PM €	TiN €
PT05	M4 - M5 - M6 M8 - M10		M4 - M5 - M6 M8 - M10		187,76	PT13 225,73

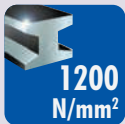

Ref. PT05

**1200
N/mm²**
CONTENUTO

	FORMA B	OX	 35°	OX	HSS V3 €	TINALOX €
PT04	M4 - M5 - M6 M8 - M10		M4 - M5 - M6 M8 - M10		199,23	PT14 298,63



Ref. PT04

**1400
N/mm²**
CONTENUTO

	FORMA B	TiCN	 15°	TiCN	HSS PM €
PT11	M4 - M5 - M6 M8 - M10		M4 - M5 - M6 M8 - M10		344,38



Ref. PT11

MASCHI A MACCHINA IN ASTUCCI

AI



Ref. PT06

CONTENUTO

	DENTI ALTERN.	2 CANALI	HSSCo 5% €
PT06	M4 - M5 - M6 M8 - M10	M4 - M5 - M6 M8 - M10	199,88

GHISA



Ref. PT07

CONTENUTO

	FORMA C	HSSCo 5% €
PT07	M4 - M5 - M6 - M8 - M10 M4 - M5 - M6 - M8 - M10	162,76

OTTONE



Ref. PT10

CONTENUTO

	FORMA C	HSSCo 5% €
PT10	M4 - M5 - M6 - M8 - M10 M4 - M5 - M6 - M8 - M10	197,84



LAMINAZIONE



Ref. PT08

CONTENUTO

		HSSCo 5% €
PT08	M4 - M5 - M6 - M8 - M10 M4 - M5 - M6 - M8 - M10	330,48



Ref. PT09

CONTENUTO

		HSSCo 5% €
PT09	M4 - M5 - M6 - M8 - M10 M4 - M5 - M6 - M8 - M10	366,66

TOL 6G



Ref. PT12

CONTENUTO

	FORMA B	 35°	HSSCo 5% €
PT12	M4 - M5 - M6 M8 - M10	M4 - M5 - M6 M8 - M10	177,45

ESPOSITORI IN METACRILATO PER MASCHI A MACCHINA
ESPOSITORE IN METACRILATO

MM-03

Composizione: Maschi a macchina, Serie Normale

HSSCo
5%
FORMA

Fori passanti, Ref. M2

B	<u>M4</u>	<u>M5</u>	<u>M6</u>	<u>M8</u>	<u>M10</u>	<u>M12</u>	<u>M14</u>
	5	10	10	10	10	5	4

Fori ciechi, Ref. M4



35°	<u>M4</u>	<u>M5</u>	<u>M6</u>	<u>M8</u>	<u>M10</u>	<u>M12</u>	<u>M14</u>
	5	10	10	10	10	5	4

Dimensioni: larghezza 240 x profondità 240 x altezza 245 mm

1.920,74 €



Ref. MM-03



Ref. MM-04

ESPOSITORE IN METACRILATO

MM-04

Composizione: Maschi a macchina, Serie Plus
Fabbricati in acciaio sinterizzato PM
HSS
PM
Plus
FORMA

Fori passanti, Ref. M2

B	<u>M4</u>	<u>M5</u>	<u>M6</u>	<u>M8</u>	<u>M10</u>	<u>M12</u>	<u>M14</u>
	5	10	10	10	10	5	4



Fori ciechi, Ref. M4

35°	<u>M4</u>	<u>M5</u>	<u>M6</u>	<u>M8</u>	<u>M10</u>	<u>M12</u>	<u>M14</u>
	5	10	10	10	10	5	4

Dimensioni: larghezza 240 x profondità 240 x altezza 245 mm

2.211,89 €

ESPOSITORE IN METACRILATO

MM-05

Composizione: Maschi a macchina per lavorazioni speciali

FORMA
B

Fori passanti Ref. M2



1200 N/mm²	<u>M4</u>	<u>M5</u>	<u>M6</u>	<u>M8</u>	<u>M10</u>	<u>M12</u>	<u>M14</u>
	1	2	2	2	2	1	1



INOX	<u>M4</u>	<u>M5</u>	<u>M6</u>	<u>M8</u>	<u>M10</u>	<u>M12</u>	<u>M14</u>
	1	2	2	2	2	1	1



AI	<u>M4</u>	<u>M5</u>	<u>M6</u>	<u>M8</u>	<u>M10</u>	<u>M12</u>	<u>M14</u>
	1	2	2	2	2	1	1



TiN	<u>M4</u>	<u>M5</u>	<u>M6</u>	<u>M8</u>	<u>M10</u>	<u>M12</u>	<u>M14</u>
	1	2	2	2	2	1	1



1400 N/mm²	<u>M4</u>	<u>M5</u>	<u>M6</u>	<u>M8</u>	<u>M10</u>	<u>M12</u>	
	1	2	2	2	2	1	



Fori ciechi, Ref. M4



1200 N/mm²	<u>M4</u>	<u>M5</u>	<u>M6</u>	<u>M8</u>	<u>M10</u>	<u>M12</u>	<u>M14</u>
	1	2	2	2	2	1	1



INOX	<u>M4</u>	<u>M5</u>	<u>M6</u>	<u>M8</u>	<u>M10</u>	<u>M12</u>	<u>M14</u>
	1	2	2	2	2	1	1



AI	<u>M4</u>	<u>M5</u>	<u>M6</u>	<u>M8</u>	<u>M10</u>	<u>M12</u>	<u>M14</u>
	1	2	2	2	2	1	1



TiN	<u>M4</u>	<u>M5</u>	<u>M6</u>	<u>M8</u>	<u>M10</u>	<u>M12</u>	<u>M14</u>
	1	2	2	2	2	1	1



1400 N/mm²	<u>M4</u>	<u>M5</u>	<u>M6</u>	<u>M8</u>	<u>M10</u>	<u>M12</u>	
	1	2	2	2	2	1	

Dimensioni: larghezza 240 x profondità 240 x altezza 245 mm

2.949,86 €