

# TARAUDS FILIÈRES



**BLUE-MASTER<sup>®</sup>**  
*by celesa*

CUTTING TECHNOLOGIES





## JEUX DE TARAUDS ET FILIÈRES HSS À MAIN

**M MF**  Réf. M0

**HSS** **DIN 352** **DIN 2181** **TOL 6H** Réf. C5 **HSS** **DIN 223** **TOL 6g**

Pour matières jusque 38 HRC



|  | Pcs      |  | M0              |               | C5     |              |  | Pcs      |  | L1 x L2 x L3<br>mm | M0     |         | C5     |  |
|--|----------|---|-----------------|---------------|--------|--------------|--|----------|--|--------------------|--------|---------|--------|--|
|  |          |   | €               | Ø x L3<br>mm  | €      | Ø x L3<br>mm |  |          |  |                    | €      |         |        |  |
| M 1x0,20   | 2        | 0,80  | 32 x 5,5 x 2,1  | 79,11         |        |              | M 5,5x0,90   | 3        | 4,60   | 50 x 16 x 4,9      | 79,50  | 25 x 9  | 22,79  |  |
| <b>M 1x0,25</b>  | <b>3</b> | <b>0,75</b>   | 32 x 6,0 x 2,1  | <b>66,92</b>  | 16 x 5 | 31,42        | M 6x0,50   | 2        | 5,50   | 50 x 14 x 4,9      | 27,21  | 20 x 5  | 28,07  |  |
| M 1,1x0,20   | 2        | 0,90  | 32 x 5,5 x 2,1  | 79,11         |        |              | M 6x0,75   | 2        | 5,25   | 50 x 14 x 4,9      | 22,91  | 25 x 9  | 24,17  |  |
| M 1,1x0,25   | 3        | 0,85  | 32 x 6,0 x 2,1  | <b>66,92</b>  | 16 x 5 | 31,42        | <b>M 6x1,00</b>  | <b>3</b> | <b>5,00</b>  | 50 x 19 x 4,9      | 17,46* | 25 x 9  | 17,02* |  |
| M 1,2x0,20   | 2        | 1,00  | 32 x 5,5 x 2,1  | 79,11         |        |              | M 6x1,25   | 3        | 4,75   | 50 x 19 x 4,9      | 131,68 | 25 x 9  | 95,55  |  |
| M 1,2x0,25   | 3        | 0,95  | 32 x 6,0 x 2,1  | <b>66,92</b>  | 16 x 5 | 31,42        | M 7x0,75   | 2        | 6,25   | 50 x 14 x 4,9      | 27,78  | 25 x 9  | 29,66  |  |
| M 1,4x0,20   | 2        | 1,20  | 32 x 7,0 x 2,1  | 79,11         |        |              | <b>M 7x1,00</b>  | <b>3</b> | <b>6,00</b>  | 50 x 19 x 4,9      | 22,09* | 25 x 9  | 24,05* |  |
| M 1,4x0,25   | 2        | 1,15  | 32 x 7,0 x 2,1  | 79,11         |        |              | M 7x1,25   | 3        | 5,75   | 50 x 19 x 4,9      | 90,63  | 25 x 9  | 118,08 |  |
| M 1,4x0,30   | 3        | 1,10  | 32 x 7,0 x 2,1  | <b>66,92</b>  | 16 x 5 | 31,42        | M 8x0,50   | 2        | 7,50   | 50 x 16 x 4,9      | 32,64  | 25 x 9  | 30,51  |  |
| M 1,6x0,20   | 2        | 1,40  | 32 x 8,0 x 2,1  | 72,18         |        |              | M 8x0,75   | 2        | 7,25   | 50 x 16 x 4,9      | 28,19  | 25 x 9  | 26,22  |  |
| M 1,6x0,25   | 2        | 1,35  | 32 x 8,0 x 2,1  | 72,18         |        |              | M 8x1,00   | 2        | 7,00   | 56 x 18 x 4,9      | 22,89* | 25 x 9  | 26,22* |  |
| M 1,6x0,35   | 3        | 1,25  | 32 x 8,0 x 2,1  | <b>66,67</b>  | 16 x 5 | 31,42        | <b>M 8x1,25</b>  | <b>3</b> | <b>6,80</b>  | 56 x 22 x 4,9      | 23,11* | 25 x 9  | 18,60* |  |
| M 1,7x0,35   | 3        | 1,35  | 32 x 8,0 x 2,1  | <b>67,11</b>  | 16 x 5 | 31,42        | M 8x1,50   | 3        | 6,50   | 56 x 22 x 4,9      | 88,16  | 25 x 9  | 105,61 |  |
| M 1,8x0,20   | 2        | 1,60  | 32 x 8,0 x 2,1  | <b>67,74</b>  |        |              | M 9x1,00   | 2        | 8,00   | 63 x 18 x 5,5      | 30,86  | 25 x 9  | 36,98  |  |
| M 1,8x0,25   | 2        | 1,55  | 32 x 8,0 x 2,1  | <b>67,74</b>  |        |              | <b>M 9x1,25</b>  | <b>3</b> | <b>7,80</b>  | 63 x 22 x 5,5      | 24,87* | 25 x 9  | 27,46* |  |
| M 1,8x0,35   | 3        | 1,45  | 32 x 8,0 x 2,1  | <b>67,11</b>  | 16 x 5 | 31,42        | M 10x0,50  | 2        | 9,50   | 63 x 18 x 5,5      | 50,05  | 30 x 10 | 88,68  |  |
| M 2x0,25   | 2        | 1,75  | 36 x 8,0 x 2,1  | <b>67,74</b>  |        |              | M 10x0,75  | 2        | 9,25   | 63 x 18 x 5,5      | 43,44  | 30 x 11 | 36,99  |  |
| M 2x0,35   | 2        | 1,65  | 36 x 8,0 x 2,1  | <b>67,74</b>  |        |              | M 10x1,00  | 2        | 9,00   | 63 x 18 x 5,5      | 24,52  | 38 x 10 | 30,51  |  |
| <b>M 2x0,40</b>  | <b>3</b> | <b>1,60</b>   | 36 x 9,0 x 2,1  | <b>29,13*</b> | 16 x 5 | 28,79*       | M 10x1,25  | 2        | 8,80   | 70 x 24 x 5,5      | 25,08  | 38 x 10 | 30,52  |  |
| M 2,2x0,45   | 3        | 1,75  | 36 x 9,0 x 2,1  | 29,63         | 20 x 5 | 28,01        | <b>M 10x1,50</b>   | <b>3</b> | <b>8,50</b>  | 70 x 24 x 5,5      | 25,07* | 38 x 10 | 21,28* |  |
| M 2,3x0,40   | 3        | 1,90  | 36 x 9,0 x 2,1  | 29,32         | 20 x 5 | 28,01        | M 11x0,75  | 2        | 10,25  | 63 x 18 x 6,2      | 74,42  | 30 x 11 | 116,97 |  |
| M 2,5x0,45   | 3        | 2,05  | 40 x 9,0 x 2,1  | 29,30         | 20 x 5 | 28,79        | M 11x1,00  | 2        | 10,00  | 63 x 18 x 6,2      | 40,18  | 30 x 11 | 41,51  |  |
| M 2,6x0,45   | 3        | 2,10  | 40 x 9,0 x 2,1  | 29,27         | 25 x 9 | 27,98        | M 11x1,25  | 2        | 9,75   | 63 x 20 x 6,2      | 40,18  | 30 x 11 | 42,60  |  |
| M 3x0,35   | 2        | 2,65  | 40 x 9,0 x 2,7  | 35,45         | 20 x 5 | 28,07        | <b>M 11x1,50</b>   | <b>3</b> | <b>9,50</b>  | 70 x 24 x 6,2      | 50,47  | 38 x 10 | 30,16  |  |
| <b>M 3x0,50</b>  | <b>3</b> | <b>2,50</b>   | 40 x 11,0 x 2,7 | <b>14,86*</b> | 25 x 9 | 16,78*       | M 12x0,75  | 2        | 11,25  | 70 x 20 x 7,0      | 39,90  | 38 x 10 | 41,50  |  |
| M 3x0,60   | 3        | 2,40  | 45 x 13,0 x 3,0 | 38,79         | 20 x 5 | 36,97        | M 12x1,00  | 2        | 11,00  | 70 x 20 x 7,0      | 40,16  | 38 x 10 | 36,98  |  |
| M 3,5x0,60   | 3        | 2,90  | 45 x 13,0 x 3,0 | 23,98         | 25 x 9 | 23,44        | M 12x1,25  | 2        | 10,75  | 70 x 20 x 7,0      | 40,04  | 38 x 10 | 36,98  |  |
| M 3,5x0,75   | 3        | 2,75  | 45 x 18,0 x 3,0 | 42,12         | 25 x 9 | 62,56        | M 12x1,50  | 2        | 10,50  | 70 x 20 x 7,0      | 36,93* | 38 x 10 | 36,02* |  |
| M 4x0,50   | 2        | 3,50  | 45 x 13,0 x 3,4 | 35,32         | 25 x 9 | 28,86        | <b>M 12x1,75</b>   | <b>3</b> | <b>10,20</b>   | 75 x 29 x 7,0      | 33,03* | 38 x 14 | 28,80* |  |
| <b>M 4x0,70</b>  | <b>3</b> | <b>3,30</b>   | 45 x 13,0 x 3,4 | <b>14,85*</b> | 25 x 9 | 16,78*       | M 13x0,75  | 2        | 12,25  | 70 x 20 x 9,0      | 76,47  | 38 x 10 | 111,60 |  |
| M 4x0,75   | 3        | 3,25  | 45 x 13,0 x 3,4 | 31,55         | 20 x 7 | 33,78        | M 13x1,00  | 2        | 12,00  | 70 x 20 x 9,0      | 62,71  | 38 x 10 | 44,28  |  |
| M 4x0,80   | 3        | 3,20  | 45 x 13,0 x 3,4 | 75,28         | 20 x 7 | 95,55        | M 13x1,25  | 2        | 11,75  | 70 x 20 x 9,0      | 64,71  | 38 x 10 | 73,55  |  |
| M 4,5x0,50   | 2        | 4,00  | 50 x 12,0 x 4,9 | 37,09         | 25 x 9 | 41,61        | M 13x1,50  | 2        | 11,50  | 70 x 20 x 9,0      | 61,65  | 38 x 10 | 44,27  |  |
| M 4,5x0,75   | 3        | 3,75  | 50 x 16,0 x 4,9 | 25,72         | 20 x 7 | 22,79        | <b>M 13x1,75</b>   | <b>3</b> | <b>11,25</b>   | 70 x 20 x 9,0      | 80,05  | 38 x 14 | 68,64  |  |
| M 5x0,50   | 2        | 4,50  | 50 x 12,0 x 4,9 | 35,58         | 20 x 5 | 28,86        | M 14x0,75  | 2        | 13,25  | 70 x 20 x 9,0      | 62,99  | 38 x 10 | 46,72  |  |
| M 5x0,75   | 2        | 4,25  | 50 x 14,0 x 4,9 | 35,46         | 20 x 7 | 28,77        | M 14x1,00  | 2        | 13,00  | 70 x 20 x 9,0      | 62,36  | 38 x 10 | 46,78  |  |
| <b>M 5x0,80</b>  | <b>3</b> | <b>4,20</b>   | 50 x 16,0 x 4,9 | <b>17,46*</b> | 25 x 9 | 17,30*       | M 14x1,25  | 2        | 12,80  | 70 x 20 x 9,0      | 46,52* | 38 x 10 | 41,63* |  |
| M 5x0,90   | 3        | 4,10  | 50 x 16,0 x 4,9 | 36,02         | 25 x 9 | 33,94        | M 14x1,50  | 2        | 12,50  | 70 x 20 x 9,0      | 39,85  | 38 x 10 | 41,63  |  |
| M 5x1,00   | 3        | 4,00  | 50 x 16,0 x 4,9 | 79,50         | 25 x 9 | 93,86        | M 14x1,75  | 2        | 12,25  | 70 x 20 x 9,0      | 77,21  | 38 x 14 | 170,02 |  |
|  |          |   |                 |               |        |              | <b>M 14x2,00</b>   | <b>3</b> | <b>12,00</b>   | 80 x 30 x 9,0      | 44,49* | 38 x 14 | 32,31* |  |
|  |          |   |                 |               |        |              | M 15x1,00  | 2        | 14,00  | 70 x 20 x 9,0      | 67,62  | 45 x 14 | 60,56  |  |
|  |          |   |                 |               |        |              | M 15x1,25  | 2        | 13,75  | 70 x 20 x 9,0      | 96,56  | 45 x 14 | 103,35 |  |
|  |          |   |                 |               |        |              | M 15x1,50  | 2        | 13,50  | 70 x 20 x 9,0      | 68,29  | 45 x 14 | 60,56  |  |
|  |          |   |                 |               |        |              | <b>M 15x2,00</b>   | <b>3</b> | <b>13,00</b>   | 80 x 30 x 9,0      | 98,90  | 45 x 14 | 93,04  |  |
|  |          |   |                 |               |        |              | M 16x1,00  | 2        | 15,00  | 70 x 20 x 9,0      | 68,02  | 45 x 14 | 60,55  |  |
|  |          |   |                 |               |        |              | M 16x1,25  | 2        | 14,75  | 70 x 20 x 9,0      | 68,43  | 45 x 14 | 62,21  |  |
|  |          |   |                 |               |        |              | M 16x1,50  | 2        | 14,50  | 70 x 20 x 9,0      | 49,01* | 45 x 14 | 49,36* |  |
|  |          |   |                 |               |        |              | <b>M 16x2,00</b>   | <b>3</b> | <b>14,00</b>   | 80 x 32 x 9,0      | 55,32* | 45 x 18 | 37,88* |  |
|  |          |   |                 |               |        |              | M 17x1,00  | 2        | 16,00  | 70 x 20 x 9,0      | 146,56 | 45 x 14 | 110,13 |  |
|  |          |   |                 |               |        |              | M 17x1,25  | 2        | 15,75  | 70 x 20 x 9,0      | 146,56 | 45 x 14 | 110,13 |  |
|  |          |   |                 |               |        |              | M 17x1,50  | 2        | 15,50  | 70 x 20 x 9,0      | 146,56 | 45 x 14 | 110,13 |  |
|  |          |   |                 |               |        |              | M 18x1,00  | 2        | 17,00  | 80 x 22 x 11,0     | 73,41  | 45 x 14 | 56,78  |  |
|  |          |   |                 |               |        |              | M 18x1,25  | 2        | 16,75  | 80 x 22 x 11,0     | 76,19  | 45 x 14 | 58,36  |  |

\*Consultez le prix de jeux de tarauds et filières à gauche disponibles à la page 188

\* Supplément pour les filières ouvertes de 20% sur le prix tarif

JEUX DE TARAUDS ET FILIÈRES HSS À MAIN

DIN 13 60°

Réf. M0

HSS

DIN 352

DIN 2181

TOL 6H

Réf. C5

HSS

DIN 223

TOL 6g

|                  |          | M0                 |                 |              |         |         | C5               |                    |             |                 |          |              |         |
|------------------|----------|--------------------|-----------------|--------------|---------|---------|------------------|--------------------|-------------|-----------------|----------|--------------|---------|
| Pcs              | Ø        | L1 x L2 x L3<br>mm | €               | Ø x L3<br>mm | €       | Pcs     | Ø                | L1 x L2 x L3<br>mm | €           | Ø x L3<br>mm    | €        |              |         |
|                  |          |                    |                 |              |         |         |                  |                    |             |                 |          | Ø x L3<br>mm | €       |
| M 18x1,50        | 2        | 16,50              | 80 x 22 x 11,0  | 55,57        | 45 x 14 | 49,36   | M 33x3,50        | 3                  | 29,5        | 125 x 50 x 20,0 | 309,50*  | 65 x 25      | 107,43* |
| M 18x2,00        | 2        | 16,00              | 80 x 22 x 11,0  | 74,08*       | 45 x 14 | 58,34*  | M 34x1,50        | 2                  | 32,5        | 100 x 25 x 22,0 | 320,82   | 65 x 18      | 131,87  |
| <b>M 18x2,50</b> | <b>3</b> | <b>15,50</b>       | 95 x 40 x 11,0  | 60,99*       | 45 x 18 | 43,03*  | M 34x2,00        | 2                  | 32,0        | 100 x 25 x 22,0 | 352,40   | 65 x 18      | 131,90  |
| M 19x1,00        | 2        | 18,00              | 80 x 22 x 11,0  | 212,69       | 45 x 14 | 178,53  | M 35x1,50        | 2                  | 33,5        | 100 x 25 x 22,0 | 308,54   | 65 x 18      | 128,23  |
| M 19x1,25        | 2        | 17,75              | 80 x 22 x 11,0  | 212,69       | 45 x 14 | 201,91  | M 35x2,00        | 2                  | 33,0        | 100 x 25 x 22,0 | 366,61   | 65 x 18      | 345,85  |
| M 19x1,50        | 2        | 17,50              | 80 x 22 x 11,0  | 212,69       | 45 x 14 | 178,53  | M 36x1,50        | 2                  | 34,5        | 100 x 25 x 22,0 | 343,89   | 65 x 18      | 128,24  |
| M 19x2,00        | 2        | 17,00              | 80 x 22 x 11,0  | 236,84       | 45 x 14 | 203,95  | M 36x2,00        | 2                  | 34,0        | 125 x 33 x 22,0 | 385,28   | 65 x 18      | 128,24  |
| M 20x1,00        | 2        | 19,00              | 80 x 22 x 12,0  | 95,39        | 45 x 14 | 56,78   | M 36x3,00        | 2                  | 33,0        | 125 x 33 x 22,0 | 419,37*  | 65 x 25      | 128,23* |
| M 20x1,25        | 2        | 18,75              | 80 x 22 x 12,0  | 91,11        | 45 x 14 | 58,36   | <b>M 36x4,00</b> | <b>3</b>           | <b>32,0</b> | 150 x 53 x 22,0 | 426,60*  | 65 x 25      | 107,44* |
| M 20x1,50        | 2        | 18,50              | 80 x 22 x 12,0  | 67,70        | 45 x 14 | 48,03   | M 38x1,50        | 2                  | 36,5        | 100 x 25 x 22,0 | 397,45   | 75 x 20      | 206,73  |
| M 20x2,00        | 2        | 18,00              | 80 x 22 x 12,0  | 95,23*       | 45 x 14 | 56,78*  | M 38x2,00        | 2                  | 36,0        | 125 x 25 x 22,0 | 482,14   | 75 x 20      | 206,73  |
| <b>M 20x2,50</b> | <b>3</b> | <b>17,50</b>       | 95 x 40 x 12,0  | 67,31*       | 45 x 18 | 43,03*  | M 39x1,50        | 2                  | 37,5        | 110 x 25 x 24,0 | 477,32   | 75 x 20      | 200,89  |
| M 21x1,00        | 2        | 20,00              | 80 x 22 x 12,0  | 267,36       | 45 x 14 | 86,35   | M 39x2,00        | 2                  | 37,0        | 125 x 23 x 24,0 | 477,32   | 75 x 20      | 200,87  |
| M 21x1,25        | 2        | 19,75              | 80 x 22 x 12,0  | 267,36       | 45 x 14 | 218,72  | M 39x3,00        | 2                  | 36,0        | 125 x 33 x 24,0 | 471,92*  | 75 x 30      | 200,89* |
| M 21x1,50        | 2        | 19,50              | 80 x 22 x 12,0  | 105,24       | 45 x 14 | 85,41   | <b>M 39x4,00</b> | <b>3</b>           | <b>35,0</b> | 150 x 53 x 24,0 | 482,78*  | 75 x 30      | 166,50* |
| M 22x1,00        | 2        | 21,00              | 80 x 22 x 14,5  | 95,01        | 55 x 16 | 88,11   | M 40x1,50        | 2                  | 38,5        | 110 x 25 x 24,0 | 466,74   | 75 x 20      | 228,72  |
| M 22x1,25        | 2        | 20,75              | 80 x 22 x 14,5  | 108,73       | 55 x 16 | 90,61   | M 40x2,00        | 2                  | 38,0        | 125 x 33 x 24,0 | 466,37   | 75 x 20      | 234,28  |
| M 22x1,50        | 2        | 20,50              | 80 x 22 x 14,5  | 86,89        | 55 x 16 | 75,59   | M 40x3,00        | 2                  | 37,0        | 125 x 33 x 24,0 | 464,65   | 75 x 30      | 200,87  |
| M 22x2,00        | 2        | 20,00              | 80 x 22 x 14,5  | 92,39*       | 55 x 16 | 88,11*  | M 42x1,50        | 2                  | 40,5        | 110 x 25 x 24,0 | 466,08   | 75 x 20      | 200,89  |
| <b>M 22x2,50</b> | <b>3</b> | <b>19,50</b>       | 100 x 40 x 14,5 | 94,14*       | 55 x 22 | 76,56*  | M 42x2,00        | 2                  | 40,0        | 125 x 33 x 24,0 | 497,95   | 75 x 20      | 200,87  |
| M 23x1,00        | 2        | 22,00              | 80 x 22 x 14,5  | 274,86       | 55 x 16 | 236,58  | M 42x3,00        | 2                  | 39,0        | 125 x 33 x 24,0 | 493,25   | 75 x 30      | 200,89  |
| M 23x1,50        | 2        | 21,50              | 80 x 22 x 14,5  | 123,74       | 55 x 16 | 90,61   | <b>M 42x4,50</b> | <b>3</b>           | <b>37,5</b> | 150 x 53 x 24,0 | 609,80   | 75 x 30      | 166,52  |
| M 24x1,00        | 2        | 23,00              | 90 x 22 x 14,5  | 122,14       | 55 x 16 | 88,11   | M 45x1,50        | 2                  | 43,5        | 110 x 25 x 29,0 | 538,89   | 90 x 22      | 320,95  |
| M 24x1,25        | 2        | 22,75              | 90 x 22 x 14,5  | 123,32       | 55 x 16 | 90,61   | M 45x2,00        | 2                  | 43,0        | 125 x 33 x 29,0 | 548,86   | 90 x 22      | 318,65  |
| M 24x1,50        | 2        | 22,50              | 90 x 22 x 14,5  | 93,62        | 55 x 16 | 75,59   | M 45x3,00        | 2                  | 42,0        | 125 x 33 x 29,0 | 548,86   | 90 x 36      | 318,63  |
| M 24x2,00        | 2        | 22,00              | 90 x 22 x 14,5  | 125,89*      | 55 x 16 | 88,11*  | <b>M 45x4,50</b> | <b>3</b>           | <b>40,5</b> | 160 x 60 x 29,0 | 703,96   | 90 x 36      | 287,29  |
| <b>M 24x3,00</b> | <b>3</b> | <b>21,00</b>       | 110 x 50 x 14,5 | 121,20*      | 55 x 22 | 76,56*  | M 48x1,50        | 2                  | 46,5        | 140 x 33 x 29,0 | 607,32   | 90 x 22      | 318,65  |
| M 25x1,00        | 2        | 24,00              | 90 x 22 x 14,5  | 183,36       | 55 x 16 | 116,42  | M 48x2,00        | 2                  | 46,0        | 140 x 33 x 29,0 | 663,78   | 90 x 22      | 318,64  |
| M 25x1,25        | 2        | 23,75              | 90 x 22 x 14,5  | 303,93       | 55 x 16 | 268,68  | M 48x3,00        | 2                  | 45,0        | 140 x 33 x 29,0 | 665,11   | 90 x 36      | 318,63  |
| M 25x1,50        | 2        | 23,50              | 90 x 22 x 14,5  | 190,06       | 55 x 16 | 113,18  | <b>M 48x5,00</b> | <b>3</b>           | <b>43,0</b> | 180 x 65 x 29,0 | 847,59   | 90 x 36      | 287,30  |
| M 25x2,00        | 2        | 23,00              | 90 x 22 x 14,5  | 381,24       | 55 x 16 | 177,63  | M 50x1,50        | 2                  | 48,5        | 140 x 33 x 29,0 | 657,97   | 90 x 22      | 320,95  |
| M 26x1,00        | 2        | 25,00              | 90 x 22 x 14,5  | 184,71       | 55 x 16 | 116,42  | M 50x3,00        | 2                  | 57,0        | 140 x 33 x 29,0 | 707,10   | 90 x 22      | 318,64  |
| M 26x1,50        | 2        | 24,50              | 90 x 22 x 14,5  | 179,16       | 55 x 16 | 94,59   | M 52x1,50        | 2                  | 50,5        | 140 x 33 x 32,0 | 691,61   | 90 x 22      | 318,63  |
| M 26x2,00        | 2        | 24,00              | 90 x 22 x 14,5  | 185,53       | 55 x 16 | 116,42  | M 52x2,00        | 2                  | 50,0        | 140 x 33 x 32,0 | 852,58   | 90 x 22      | 318,64  |
| M 27x1,00        | 2        | 26,00              | 90 x 22 x 16,0  | 185,54       | 65 x 18 | 128,23  | M 52x3,00        | 2                  | 49,0        | 140 x 33 x 32,0 | 860,22   | 90 x 36      | 318,64  |
| M 27x1,50        | 2        | 25,50              | 90 x 22 x 16,0  | 188,98       | 65 x 18 | 142,49  | <b>M 52x5,00</b> | <b>3</b>           | <b>47,0</b> | 180 x 65 x 32,0 | 1.020,13 | 90 x 36      | 287,30  |
| M 27x2,00        | 2        | 25,00              | 90 x 22 x 16,0  | 225,49*      | 65 x 18 | 128,24* | <b>M 56x4,00</b> | <b>2</b>           | <b>52,0</b> | 180 x 47 x 32,0 | 1.010,55 | 105 x 36     |         |
| <b>M 27x3,00</b> | <b>3</b> | <b>24,00</b>       | 110 x 50 x 16,0 | 169,04*      | 65 x 25 | 90,70*  | <b>M 56x5,50</b> | <b>3</b>           | <b>50,5</b> | 200 x 85 x 35,0 | 1.348,89 | 105 x 36     |         |
| M 28x1,00        | 2        | 27,00              | 90 x 22 x 16,0  | 223,09       | 65 x 18 | 131,90  | <b>M 60x5,50</b> | <b>3</b>           | <b>54,5</b> | 200 x 85 x 35,0 | 1.655,14 | 105 x 36     |         |
| M 28x1,50        | 2        | 26,50              | 90 x 22 x 16,0  | 199,02       | 65 x 18 | 128,24  | <b>M 64x4,00</b> | <b>2</b>           | <b>60,0</b> | 180 x 50 x 35,0 | 1.556,36 | 120 x 36     |         |
| M 28x2,00        | 2        | 26,00              | 90 x 22 x 16,0  | 221,81       | 65 x 18 | 128,23  | <b>M 64x6,00</b> | <b>3</b>           | <b>58,0</b> | 220 x 90 x 39,0 | 1.921,83 | 120 x 36     |         |
| M 30x1,00        | 2        | 29,00              | 90 x 22 x 18,0  | 223,10       | 65 x 18 | 128,24  | <b>M 68x6,00</b> | <b>3</b>           | <b>62,0</b> | 220 x 90 x 39,0 | 2.344,64 | 120 x 36     |         |
| M 30x1,50        | 2        | 28,50              | 90 x 22 x 18,0  | 212,10       | 65 x 18 | 142,47  | <b>M 72x6,00</b> | <b>3</b>           | <b>66,0</b> | 235 x 90 x 39,0 | 2.540,13 | 120 x 36     |         |
| M 30x2,00        | 2        | 28,00              | 90 x 22 x 18,0  | 244,52       | 65 x 18 | 128,24  |                  |                    |             |                 |          |              |         |
| M 30x3,00        | 2        | 27,00              | 125 x 56 x 18,0 | 239,04*      | 65 x 25 | 131,89* |                  |                    |             |                 |          |              |         |
| <b>M 30x3,50</b> | <b>3</b> | <b>26,50</b>       | 125 x 50 x 18,0 | 211,68*      | 65 x 25 | 107,44* |                  |                    |             |                 |          |              |         |
| M 32x1,00        | 2        | 31,00              | 90 x 22 x 18,0  | 307,76       | 65 x 18 | 258,61  |                  |                    |             |                 |          |              |         |
| M 32x1,50        | 2        | 30,50              | 90 x 22 x 18,0  | 261,81       | 65 x 18 | 128,23  |                  |                    |             |                 |          |              |         |
| M 32x2,00        | 2        | 30,00              | 90 x 22 x 18,0  | 326,78       | 65 x 18 | 131,90  |                  |                    |             |                 |          |              |         |
| M 33x1,00        | 2        | 32,00              | 100 x 25 x 20,0 | 495,83       | 65 x 18 | 268,68  |                  |                    |             |                 |          |              |         |
| M 33x1,50        | 2        | 31,50              | 100 x 25 x 20,0 | 270,09       | 65 x 18 | 131,90  |                  |                    |             |                 |          |              |         |
| M 33x2,00        | 2        | 31,00              | 100 x 25 x 20,0 | 363,54       | 65 x 18 | 131,90  |                  |                    |             |                 |          |              |         |
| M 33x3,00        | 2        | 30,00              | 125 x 56 x 20,0 | 421,42*      | 65 x 25 | 131,89* |                  |                    |             |                 |          |              |         |

| FILIÈRES AVEC CAGE EN POUÇES |              |       |           |              |       |
|------------------------------|--------------|-------|-----------|--------------|-------|
|                              |              |       | C5        |              |       |
|                              | Ø x L3<br>mm | €     |           | Ø x L3<br>mm | €     |
| M 3x0,50                     | 25,4 x 9,5   | 19,58 | M 8x1,25  | 38,1 x 12,7  | 26,62 |
| M 4x0,70                     | 25,4 x 9,5   | 19,58 | M 10x1,50 | 25,4 x 9,5   | 24,59 |
| M 5x0,80                     | 25,4 x 9,5   | 19,42 | M 10x1,50 | 38,1 x 12,7  | 33,01 |
| M 6x1,00                     | 25,4 x 9,5   | 19,58 | M 12x1,75 | 25,4 x 9,5   | 24,35 |
| M 8x1,25                     | 25,4 x 9,5   | 19,60 | M 12x1,75 | 38,1 x 12,7  | 33,29 |

\*Consultez le prix de jeux de tarauds et filières à gauche disponibles à la page 188  
\* Supplément pour les filières ouvertes de 20% sur le prix tarif

**JEUX DE TARAUDS ET FILIÈRES HSS À MAIN**

UNC

Réf. M0

Réf. C5

**HSS**  
**DIN 351**  
**TOL 2B**

**HSS**  
**DIN 223**  
**TOL 2a**

UNF

Réf. M0

Réf. C5

**HSS**  
**DIN 2181**  
**TOL 2B**

**HSS**  
**DIN 223**  
**TOL 2a**



| Icon          | Pcs. | D1 mm | L1    | L2 x L3     | M0       |           | C5     |  |
|---------------|------|-------|-------|-------------|----------|-----------|--------|--|
|               |      |       |       |             | €        | Ø x L3 mm | €      |  |
| UNC n°1-64h.  | 3    | 1,85  | 1,50  | 36x8x2,1    | 107,34   | 16x5      |        |  |
| UNC n°2-56h.  | 3    | 2,18  | 1,80  | 36x9x2,1    | 75,85    | 16x5      |        |  |
| UNC n°3-48h.  | 3    | 2,51  | 2,10  | 40x9x2,1    | 75,85    | 16x5      |        |  |
| UNC n°4-40h.  | 3    | 2,84  | 2,25  | 40x11x2,7   | 55,76    | 20x5      | 35,99  |  |
| UNC n°5-40h.  | 3    | 3,17  | 2,60  | 40x11x2,7   | 55,96    | 20x5      | 35,99  |  |
| UNC n°6-32h.  | 3    | 3,50  | 2,75  | 45x13x3,0   | 55,96    | 20x7      | 35,99  |  |
| UNC n°8-32h.  | 3    | 4,17  | 3,50  | 45x13x3,4   | 55,96    | 20x7      | 35,99  |  |
| UNC n°10-24h. | 3    | 4,83  | 3,90  | 50x16x4,9   | 55,96    | 20x7      | 35,99  |  |
| UNC n°12-24h. | 3    | 5,49  | 4,50  | 50x19x4,9   | 55,96    | 20x7      | 35,99  |  |
| UNC 1/4-20h.  | 3    | 6,35  | 5,10  | 50x19x4,9   | 30,15*   | 20x7      | 30,06* |  |
| UNC 5/16-18h. | 3    | 7,94  | 6,60  | 56x22x4,9   | 33,20*   | 25x9      | 33,31* |  |
| UNC 3/8-16h.  | 3    | 9,52  | 8,00  | 70x24x5,5   | 37,16*   | 30x11     | 35,13* |  |
| UNC 7/16-14h. | 3    | 11,11 | 9,40  | 70x24x6,2   | 46,09    | 38x14     | 40,49  |  |
| UNC 1/2-13h.  | 3    | 12,70 | 10,75 | 75x29x7,0   | 61,86*   | 38x14     | 45,09* |  |
| UNC 9/16-12h. | 3    | 14,28 | 12,20 | 80x30x9,0   | 73,04    | 38x14     | 49,79  |  |
| UNC 5/8-11h.  | 3    | 15,87 | 13,50 | 80x32x9,0   | 82,74*   | 45x18     | 49,61* |  |
| UNC 3/4-10h.  | 3    | 19,05 | 16,50 | 95x40x11,0  | 109,81*  | 45x18     | 58,24* |  |
| UNC 7/8-9h.   | 3    | 22,22 | 19,50 | 100x40x14,5 | 135,17   | 55x22     | 86,38  |  |
| UNC 1"-8h.    | 3    | 25,40 | 22,25 | 110x50x14,5 | 162,98*  | 55x22     | 86,38* |  |
| UNC 1.1/8-7h. | 3    | 28,57 | 25,00 | 125x56x18,0 | 334,20   | 65x25     | 140,02 |  |
| UNC 1.1/4-7h. | 3    | 31,75 | 28,00 | 125x56x18,0 | 395,91   | 65x25     | 140,02 |  |
| UNC 1.3/8-6h. | 3    | 34,92 | 30,75 | 150x63x22,0 | 612,11   | 65x25     | 140,02 |  |
| UNC 1.1/2-6h. | 3    | 38,10 | 34,00 | 150x63x24,0 | 597,38   | 75x30     | 140,03 |  |
| UNC 2"-4,5h.  | 3    | 50,80 | 45,00 | 180x75x32,0 | 1.224,47 | 90x36     |        |  |

| Icon           | Pcs. | D1 mm | L1    | L2 x L3     | M0       |           | C5      |  |
|----------------|------|-------|-------|-------------|----------|-----------|---------|--|
|                |      |       |       |             | €        | Ø x L3 mm | €       |  |
| UNF n°2-64h.   | 2    | 2,18  | 1,85  | 36x8x2,1    | 66,71    |           |         |  |
| UNF n°3-56h.   | 2    | 2,51  | 2,15  | 40x9x2,1    | 56,71    |           |         |  |
| UNF n°4-48h.   | 2    | 2,84  | 2,35  | 40x9x2,7    | 34,09    | 20x5      | 35,99   |  |
| UNF n°5-44h.   | 2    | 3,17  | 2,70  | 45x10x2,7   | 34,09    | 20x5      | 35,99   |  |
| UNF n°6-40h.   | 2    | 3,50  | 2,95  | 45x16x3,0   | 33,75    | 20x5      | 35,99   |  |
| UNF n°8-36h.   | 2    | 4,17  | 3,50  | 50x12x3,4   | 33,75    | 20x7      | 35,99   |  |
| UNF n°10-32h.  | 2    | 4,83  | 4,10  | 50x12x4,9   | 33,75    | 20x7      | 35,99   |  |
| UNF n°12-28h.  | 2    | 5,49  | 4,60  | 50x12x4,9   | 33,75    | 20x7      | 35,99   |  |
| UNF 1/4-28h.   | 2    | 6,35  | 5,50  | 50x14x4,9   | 20,61*   | 25x9      | 30,06*  |  |
| UNF 5/16-24h.  | 2    | 7,94  | 6,90  | 56x22x4,9   | 20,45*   | 25x9      | 33,32*  |  |
| UNF 3/8-24h.   | 2    | 9,52  | 8,50  | 63x20x5,5   | 29,61*   | 38x10     | 34,57*  |  |
| UNF 7/16-20h.  | 2    | 11,11 | 9,90  | 63x20x6,2   | 34,32    | 38x10     | 40,50   |  |
| UNF 1/2-20h.   | 2    | 12,70 | 11,50 | 70x22x7,0   | 36,63*   | 38x10     | 45,09*  |  |
| UNF 9/16-18h.  | 2    | 14,29 | 12,90 | 70x22x9,0   | 45,09    | 38x10     | 48,68   |  |
| UNF 5/8-18h.   | 2    | 15,87 | 14,50 | 70x22x9,0   | 51,38*   | 45x14     | 49,61*  |  |
| UNF 3/4-16h.   | 2    | 19,05 | 17,50 | 80x22x11,0  | 66,72*   | 45x14     | 58,24*  |  |
| UNF 7/8-14h.   | 2    | 22,22 | 20,40 | 80x22x14,5  | 88,71*   | 55x16     | 86,38*  |  |
| UNF 1"-12h.    | 2    | 25,40 | 23,25 | 90x22x16,0  | 131,37   | 55x16     | 86,38   |  |
| UNF 1"-14h.    | 2    | 25,40 | 23,60 | 90x22x14,5  | 148,48*  | 55x16     | 112,69* |  |
| UNF 1.1/8-12h. | 2    | 28,57 | 26,50 | 90x22x18,0  | 158,42   | 65x18     | 140,03  |  |
| UNF 1.1/4-12h. | 2    | 31,75 | 29,50 | 90x22x20,0  | 227,69   | 65x18     | 140,68  |  |
| UNF 1.3/8-12h. | 2    | 34,92 | 32,80 | 125x35x22,0 | 248,27   | 65x18     | 140,68  |  |
| UNF 1.1/2-12h. | 2    | 38,10 | 36,00 | 125x40x22,0 | 379,45   | 75x20     | 219,96  |  |
| UNF 2"-12h.    | 2    | 50,80 | 48,38 | 140x40x29,0 | 1.192,31 | 90x22     |         |  |

JEUX DE TARAUDS ET FILIÈRES HSS À MAIN



Tarouds et filières  
Rose  
Vert

| Icon         | Pcs. | D1 mm  | L1 x L2 x mm | M0              |          | C5       |         | Icon        | Pcs. | MOT    |        | C5T    |        | MOX   |    | CSX |       |
|--------------|------|--------|--------------|-----------------|----------|----------|---------|-------------|------|--------|--------|--------|--------|-------|----|-----|-------|
|              |      |        |              | HSS             | €        | HSS      | €       |             |      | HSS    | €      | HSS    | €      | HSSCo | OX | €   | HSSCo |
| G 1/8-28h.   | 2    | 9,73   | 8,80         | 63 x 20 x 5,5   | 30,96*   | 38 x 10  | 41,87*  | G 1/8-28 h. | 2    | 66,39  | 65,08  | 76,27  | 50,56  |       |    |     |       |
| G 1/4-19h.   | 2    | 13,16  | 11,80        | 70 x 22 x 9,0   | 33,07*   | 38 x 10  | 42,95*  | G 1/4-19 h. | 2    | 89,91  | 70,23  | 102,05 | 52,88  |       |    |     |       |
| G 3/8-19h.   | 2    | 16,66  | 15,25        | 70 x 22 x 9,0   | 48,43*   | 45 x 14  | 53,12*  | G 3/8-19 h. | 2    | 129,35 | 75,76  | 149,46 | 65,15  |       |    |     |       |
| G 1/2-14h.   | 2    | 20,95  | 19,00        | 80 x 22 x 12,0  | 80,06*   | 45 x 14  | 53,12*  | G 1/2-14 h. | 2    | 216,93 | 85,76  | 239,96 | 63,50  |       |    |     |       |
| G 5/8-14h.   | 2    | 22,91  | 21,00        | 80 x 22 x 14,5  | 100,36*  | 55 x 16  | 84,26*  |             |      |        |        |        |        |       |    |     |       |
| G 3/4-14h.   | 2    | 26,44  | 24,50        | 90 x 22 x 16,0  | 115,53*  | 55 x 16  | 84,25*  | G 3/4-14 h. | 2    | 251,28 | 139,71 | 304,12 | 102,47 |       |    |     |       |
| G 7/8-14h.   | 2    | 30,20  | 28,25        | 90 x 22 x 18,0  | 185,56   | 65 x 18  | 108,35  |             |      |        |        |        |        |       |    |     |       |
| G 1"-11h.    | 2    | 33,25  | 30,75        | 100 x 25 x 20,0 | 166,49*  | 65 x 18  | 108,34* | G 1" -11 h. | 2    | 395,75 | 186,63 | 452,02 | 132,62 |       |    |     |       |
| G 1.1/8-11h. | 2    | 37,90  | 35,50        | 125 x 40 x 22,0 | 348,74   | 75 x 20  | 167,37  |             |      |        |        |        |        |       |    |     |       |
| G 1.1/4-11h. | 2    | 41,91  | 39,50        | 125 x 40 x 24,0 | 267,83*  | 75 x 20  | 167,38* |             |      |        |        |        |        |       |    |     |       |
| G 1.3/8-11h. | 2    | 44,32  | 42,00        | 125 x 40 x 29,0 | 462,10   | 90 x 22  | 249,03  |             |      |        |        |        |        |       |    |     |       |
| G 1.1/2-11h. | 2    | 47,80  | 45,25        | 140 x 40 x 29,0 | 393,83   | 90 x 22  | 249,03  |             |      |        |        |        |        |       |    |     |       |
| G 1.3/4-11h. | 2    | 53,75  | 51,25        | 140 x 40 x 32,0 | 745,67   | 105 x 22 | 258,95  |             |      |        |        |        |        |       |    |     |       |
| G 2"-11h.    | 2    | 59,61  | 57,00        | 160 x 40 x 35,0 | 667,34   | 105 x 22 | 278,09  |             |      |        |        |        |        |       |    |     |       |
| G 2.1/4-11h. | 2    | 65,71  | 63,00        | 160 x 40 x 39,0 | 1.570,07 | 105 x 22 |         |             |      |        |        |        |        |       |    |     |       |
| G 2.1/2-11h. | 2    | 75,18  | 72,50        | 160 x 40 x 39,0 | 1.857,86 | 120 x 22 |         |             |      |        |        |        |        |       |    |     |       |
| G 2.3/4-11h. | 2    | 81,53  | 79,00        | 160 x 40 x 39,0 | 2.709,50 | 120 x 22 |         |             |      |        |        |        |        |       |    |     |       |
| G 3"-11h.    | 2    | 87,88  | 85,50        | 160 x 40 x 39,0 | 2.820,02 | 150 x 25 |         |             |      |        |        |        |        |       |    |     |       |
| G 4"-11h.    | 2    | 113,03 | 110,50       | 180 x 45 x 44,0 | 4.277,02 | 180 x 25 |         |             |      |        |        |        |        |       |    |     |       |



| Icon           | Pcs. | D1 mm | L1 x L2 x mm | €     |
|----------------|------|-------|--------------|-------|
| UNF n°4-48-3B  | 2    | 2,84  | 40x9x2,7     | 52,95 |
| UNF n°5-44-3B  | 2    | 3,17  | 45x10x2,7    | 52,95 |
| UNF n°6-40-3B  | 2    | 3,50  | 45x16x3,0    | 52,94 |
| UNF n°8-36-3B  | 2    | 4,17  | 50x12x3,4    | 52,94 |
| UNF n°10-32-3B | 2    | 4,83  | 50x12x4,9    | 52,94 |
| UNF n°12-28-3B | 2    | 5,49  | 50x12x4,9    | 52,95 |
| UNF 1/4-28-3B  | 2    | 6,35  | 50x14x4,9    | 38,61 |
| UNF 5/16-24-3B | 2    | 7,94  | 56x22x4,9    | 41,34 |
| UNF 3/8-24-3B  | 2    | 9,52  | 63x20x5,5    | 47,72 |
| UNF 7/16-20-3B | 2    | 11,11 | 63x20x6,2    | 63,35 |
| UNF 1/2-20-3B  | 2    | 12,70 | 70x22x7,0    | 64,81 |

\*Consultez le prix de jeux de tarauds et filières à gauche disponibles à la page 188

**JEUX DE TARAUDS ET FILIÈRES HSS À MAIN**

**BSW**

Ref. M0

Ref. C5

**HSS**

**DIN 351**

**TOL Classe 2**

**HSS**

**DIN 223**

**BSF**

Ref. M0

Ref. C5

**HSS**

**DIN 5157**

**TOL ISO 228**

**HSS**

**DIN 223**



| Icon          | Pcs | D1 mm | L1 x L2 x mm | M0          |           | C5     |        |
|---------------|-----|-------|--------------|-------------|-----------|--------|--------|
|               |     |       |              | €           | Ø x L3 mm | €      | €      |
| W 1/16-60h.   | 3   | 1,59  | 1,15         | 32x8x2,1    | 38,36     | 16x5   | 77,07  |
| W 3/32-48h.   | 3   | 2,38  | 1,80         | 40x9x2,1    | 41,87     | 20x5   | 29,81  |
| W 1/8-40h.    | 3   | 3,17  | 2,55         | 40x14x2,7   | 30,07*    | 25x9   | 30,06* |
| W 5/32-32h.   | 3   | 3,97  | 3,10         | 45x17x3,4   | 28,57     | 25x9   | 30,06  |
| W 3/16-24h.   | 3   | 4,76  | 3,60         | 50x19x4,9   | 28,58     | 25x9   | 30,06  |
| W 7/32-24h.   | 3   | 5,55  | 4,40         | 50x19x4,9   | 28,20     | 25x9   | 30,07  |
| W 1/4-20h.    | 3   | 6,35  | 5,10         | 50x20x4,9   | 28,46*    | 25x9   | 30,06* |
| W 5/16-18h.   | 3   | 7,94  | 6,50         | 56x20x4,9   | 33,10*    | 25x9   | 33,32* |
| W 3/8-16h.    | 3   | 9,52  | 7,90         | 63x22x5,5   | 40,93*    | 38x10  | 35,99* |
| W 7/16-14h.   | 3   | 11,11 | 9,25         | 70x22x6,2   | 43,94     | 38x10  | 40,49  |
| W 1/2-12h.    | 3   | 12,70 | 10,50        | 75x25x7,0   | 64,83     | 38x14  | 45,10  |
| W 9/16-12h.   | 3   | 14,29 | 12,00        | 80x26x9,0   | 68,59     | 38x14  | 53,68  |
| W 5/8-11h.    | 3   | 15,87 | 13,40        | 80x27x9,0   | 78,89*    | 45x18  | 54,49* |
| W 11/16-11h.  | 3   | 17,46 | 15,25        | 95x32x11,0  | 232,48    | 45x18  | 54,70  |
| W 3/4-10h.    | 3   | 19,05 | 16,50        | 95x32x11,0  | 104,99*   | 45x18  | 58,26* |
| W 7/8-9h.     | 3   | 22,22 | 19,25        | 100x32x14,5 | 129,45*   | 55x22  | 86,37* |
| W 1"-8h.      | 3   | 25,40 | 21,75        | 110x36x14,5 | 212,35*   | 55x22  | 86,37* |
| W 1.1/8-7h.   | 3   | 28,57 | 24,75        | 125x40x18,0 | 267,71    | 65x25  | 161,37 |
| W 1.1/4-7h.   | 3   | 31,75 | 27,75        | 125x40x18,0 | 297,65    | 65x25  | 161,44 |
| W 1.3/8-6h.   | 3   | 34,92 | 30,50        | 150x50x22,0 | 408,26    | 65x25  | 164,42 |
| W 1.1/2-6h.   | 3   | 38,10 | 33,50        | 150x50x24,0 | 458,74    | 75x30  | 249,93 |
| W 1.5/8-5h.   | 3   | 41,27 | 46,50        | 150x56x24,0 | 825,68    | 75x30  | 299,68 |
| W 1.3/4-5h.   | 3   | 44,45 | 39,00        | 160x58x29,0 | 832,44    | 90x36  | 377,16 |
| W 1.7/8-4,5h. | 3   | 47,62 | 42,00        | 180x65x29,0 | 1.172,89  | 90x36  | 412,68 |
| W 2"-4,5h.    | 3   | 50,80 | 44,50        | 180x65x32,0 | 1.304,62  | 90x36  | 432,51 |
| W 2.1/4-4h.   | 3   | 57,15 | 50,00        | 200x85x35,0 | 2.428,88  | 105x36 |        |
| W 2.1/2-4h.   | 3   | 63,50 | 56,50        | 220x85x39,0 | 2.954,77  | 120x36 |        |
| W 2.3/4-3,5h. | 3   | 69,85 | 62,00        | 250x90x44,0 | 4.219,04  | 120x36 |        |
| W 3"-3,5h.    | 3   | 76,20 | 68,00        | 250x90x44,0 | 4.880,98  | 140x36 |        |

| Icon          | Pcs | D1 mm | L1 x L2 x mm | M0          |           | C5    |        |
|---------------|-----|-------|--------------|-------------|-----------|-------|--------|
|               |     |       |              | €           | Ø x L3 mm | €     | €      |
| BSF 3/16-32h. | 2   | 4,76  | 4,0          | 50x19x4,9   | 28,30     | 20x7  | 30,06  |
| BSF 1/4-26h.  | 2   | 6,35  | 5,2          | 50x20x4,9   | 28,09     | 20x7  | 30,07  |
| BSF 5/16-22h. | 2   | 7,94  | 6,6          | 56x20x4,9   | 28,19     | 25x9  | 33,32  |
| BSF 3/8-20h.  | 2   | 9,52  | 8,1          | 63x22x5,5   | 39,75     | 30x11 | 38,66  |
| BSF 7/16-18h. | 2   | 11,11 | 9,5          | 70x22x6,2   | 37,65     | 30x11 | 40,50  |
| BSF 1/2-16h.  | 2   | 12,70 | 11,0         | 75x25x7,0   | 53,13     | 38x10 | 54,77  |
| BSF 9/16-16h. | 2   | 14,29 | 12,5         | 80x26x9,0   | 68,74     | 38x10 | 60,12  |
| BSF 5/8-14h.  | 2   | 15,88 | 14,0         | 80x26x9,0   | 66,14     | 45x14 | 80,22  |
| BSF 3/4-12h.  | 2   | 19,05 | 16,5         | 95x33x11,0  | 90,99     | 45x14 | 80,22  |
| BSF 7/8-11h.  | 2   | 22,23 | 19,5         | 100x33x14,5 | 103,77    | 55x22 | 100,34 |
| BSF 1"-10h.   | 2   | 25,40 | 22,5         | 110x40x14,5 | 138,89    | 55x22 | 100,33 |
| BSF 1.1/8-9h. | 2   | 28,57 | 25,5         | 110x40x16,0 | 535,05    |       |        |
| BSF 1.1/4-9h. | 2   | 31,75 | 28,5         | 125x46x18,0 | 610,86    |       |        |
| BSF 1.1/2-8h. | 2   | 38,10 | 34,5         | 150x55x22,0 | 930,99    |       |        |

**BSW**

**INOX**

**TiN**

| Icon         | Pcs | L1 x L2 x mm   | M0T    |           | C5T   |   |
|--------------|-----|----------------|--------|-----------|-------|---|
|              |     |                | €      | Ø x L3 mm | €     | € |
| W 3/16-24 h. | 3   | 50 x 19 x 4,90 | 54,55  | 25x9      | 43,05 |   |
| W 1/4-20 h.  | 3   | 50 x 20 x 4,90 | 54,00  | 25x9      | 44,41 |   |
| W 5/16-18 h. | 3   | 56 x 20 x 4,90 | 56,35  | 25x9      | 50,42 |   |
| W 3/8-16 h.  | 3   | 63 x 22 x 5,50 | 74,60  | 38x10     | 45,25 |   |
| W 1/2-12 h.  | 3   | 75 x 25 x 7,00 | 115,78 | 38x14     | 78,15 |   |



\*Consultez le prix de jeux de tarauds et filières à gauche disponibles à la page 188

JEU DE TARAUDS ET FILIÈRES HSS À MAIN

**NPTF**

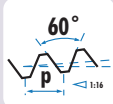

Pas AMÉRICAIN  
Filetage Conique Étanche

**HSS**

Réf. M0

**HSS**

Réf. C5

**DIN  
223**

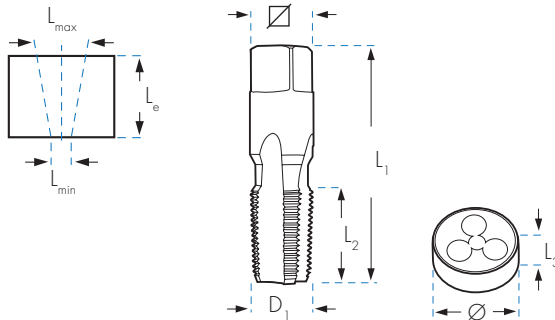

|                 |  |     |       |      |  |                   | M0                                |        | C5                    |        |
|-----------------|--|-----|-------|------|--|-------------------|-----------------------------------|--------|-----------------------|--------|
|                 |  | Pcs | D1 mm |      | L <sub>min</sub> x L <sub>max</sub> mm | L <sub>e</sub> mm | L <sub>1</sub> x L <sub>2</sub> x | €      | Ø x L <sub>3</sub> mm | €      |
| NPTF 1/8-27 h.  |  | 1   | 10,22 | 8,5  | 8,30 x 8,76                            | 12,0              | 54 x 19 x 8,0                     | 83,71  | 38 x 10               | 182,83 |
| NPTF 1/4-18 h.  |  | 1   | 13,58 | 11,0 | 10,70 x 11,40                          | 17,5              | 62 x 27 x 11,0                    | 117,34 | 38 x 15               | 182,83 |
| NPTF 3/8-18 h.  |  | 1   | 17,02 | 14,5 | 14,20 x 14,84                          | 17,6              | 65 x 27 x 13,0                    | 161,99 | 45 x 14               | 238,72 |
| NPTF 1/2-14 h.  |  | 1   | 21,21 | 17,8 | 17,40 x 18,33                          | 22,8              | 80 x 35 x 13,0                    | 226,52 | 45 x 20               | 238,72 |
| NPTF 3/4-14 h.  |  | 1   | 26,56 | 23,0 | 22,80 x 23,68                          | 23,0              | 83 x 35 x 17,0                    | 346,25 | 55 x 22               | 454,98 |
| NPTF 1"-11,5 h. |  | 1   | 33,19 | 29,0 | 28,60 x 29,72                          | 27,4              | 110 x 38 x 20,0                   | 461,20 |                       |        |

**NPT**

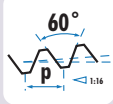

Pas AMÉRICAIN  
Filetage Conique Non Étanche (Briggs)

**HSS**

Réf. M0

**HSS**

Réf. C5

**DIN  
223**

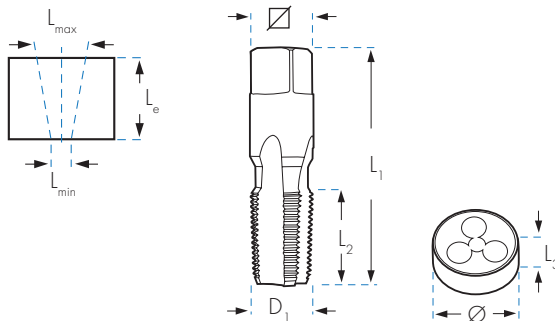

|                   |  |     |       |       |           |  |                   | M0                                |          | C5                    |        |
|-------------------|--|-----|-------|-------|-----------|--|-------------------|-----------------------------------|----------|-----------------------|--------|
|                   |  | Pcs | D1 mm |       |           | L <sub>min</sub> x L <sub>max</sub> mm | L <sub>e</sub> mm | L <sub>1</sub> x L <sub>2</sub> x | €        | Ø x L <sub>3</sub> mm | €      |
| NPT 1/16-27 h.    |  | 1   | 7,89  | 6,20  | EMNPT1/16 | 6,00 x 6,38                            | 12,0              | 54 x 18 x 6,0                     | 35,04    | 25 x 9                | 78,84  |
| NPT 1/8-27 h.     |  | 1   | 10,24 | 8,50  | EMNPT1/8  | 8,30 x 8,73                            | 12,0              | 65 x 19 x 5,5                     | 36,79    | 30 x 11               | 84,66  |
| NPT 1/4-18 h.     |  | 1   | 13,62 | 11,00 | EMNPT1/4  | 10,70 x 11,35                          | 17,5              | 62 x 27 x 11,0                    | 51,61    | 38 x 14               | 100,39 |
| NPT 3/8-18 h.     |  | 1   | 17,05 | 14,50 | EMNPT3/8  | 14,20 x 14,80                          | 17,6              | 65 x 27 x 13,0                    | 71,23    | 45 x 18               | 125,27 |
| NPT 1/2-14 h.     |  | 1   | 21,23 | 17,80 | EMNPT1/2  | 17,40 x 18,32                          | 22,8              | 80 x 35 x 13,0                    | 99,60    | 45 x 18               | 125,27 |
| NPT 3/4-14 h.     |  | 1   | 26,57 | 23,00 | -         | 22,80 x 23,66                          | 23,0              | 83 x 35 x 17,0                    | 152,26   | 55 x 22               | 197,06 |
| NPT 1"-11,5 h.    |  | 1   | 33,23 | 29,00 | -         | 28,60 x 29,69                          | 27,4              | 95 x 44 x 21,0                    | 169,57   | 65 x 25               | 285,45 |
| NPT 1.1/4-11,5 h. |  | 1   | 41,98 | 37,50 | -         | 37,40 x 38,45                          | 28,1              | 125 x 33 x 24,0                   | 278,03   | 75 x 26               | 320,82 |
| NPT 1.1/2-11,5 h. |  | 1   | 48,05 | 44,00 | -         | 43,40 x 44,52                          | 28,4              | 140 x 33 x 29,0                   | 422,47   | 90 x 27               | 447,60 |
| NPT 2"-11,5 h.    |  | 1   | 60,09 | 56,00 | -         | 55,50 x 56,56                          | 28,4              | 160 x 33 x 35,0                   | 659,56   | 105 x 36              | 623,17 |
| NPT 2.1/2"-8h.    |  | 1   | 73,03 | 67,00 | -         | 68,68 x 69,08                          | 28,9              | 200 x 45 x 39,0                   | 813,66   |                       |        |
| NPT 3"-8h.        |  | 1   | 88,90 | 82,00 | -         | 84,45 x 84,86                          | 30,5              | 220 x 48 x 39,0                   | 1.143,70 |                       |        |

\* Voir alésoir pour avant-trou p.137

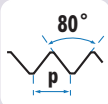
**JEUX DE TARAUDS ET FILIÈRES HSS À MAIN**
**PG**

Réf. M0

**HSS**
**DIN  
40430**

Réf. C5

**HSS**
**DIN  
223**

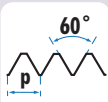

| Icon    | Icon | Pcs | D1<br>mm | L1 x L2 x L3<br>mm | M0     |              | C5     |  |
|---------|------|-----|----------|--------------------|--------|--------------|--------|--|
|         |      |     |          |                    | €      | Ø x L3<br>mm | €      |  |
|         |      |     |          |                    |        |              |        |  |
| Pg 7    | 20h. | 1   | 12,5     | 11,50 70x20x7,0    | 37,48  | 38x10        | 69,35  |  |
| Pg 9    | 18h. | 1   | 15,2     | 14,00 70x20x9,0    | 47,66  | 38x10        | 84,47  |  |
| Pg 11   | 18h. | 1   | 18,6     | 17,25 80x22x11,0   | 66,17  | 45x14        | 84,48  |  |
| Pg 13,5 | 18h. | 1   | 20,4     | 19,00 80x22x12,0   | 72,56  | 45x14        | 84,48  |  |
| Pg 16   | 18h. | 1   | 22,5     | 21,25 80x22x14,5   | 87,14  | 55x16        | 97,50  |  |
| Pg 21   | 16h. | 1   | 28,3     | 27,00 90x22x18,0   | 128,14 | 65x18        | 147,02 |  |
| Pg 29   | 16h. | 1   | 37,0     | 35,50 100x25x22,0  | 254,45 | 65x18        | 147,02 |  |
| Pg 36   | 16h. | 1   | 47,0     | 45,50 140x32x29,0  | 373,94 | 90x22        | 418,82 |  |
| Pg 42   | 16h. | 1   | 54,0     | 52,50 140x36x32,0  | 444,06 | 105x22       | 418,82 |  |
| Pg 48   | 16h. | 1   | 59,3     | 58,00 160x36x35,0  | 560,05 | 105x22       | 555,39 |  |

**NPSF**

**Pas AMÉRICAIN**  
 Filetage Cylindrique  
 Étanche

Réf. M0

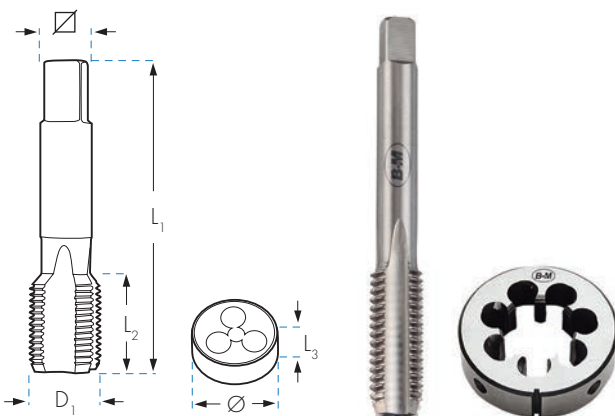
**HSS**

Réf. C5

**HSS**
**DIN  
223**

| Icon           | Icon | Pcs   | D1<br>mm | L1 x L2 x L3<br>mm | M0     |              | C5     |  |
|----------------|------|-------|----------|--------------------|--------|--------------|--------|--|
|                |      |       |          |                    | €      | Ø x L3<br>mm | €      |  |
|                |      |       |          |                    |        |              |        |  |
| NPSF 1/8-27 h. | 1    | 10,05 | 8,75     | 63x18x5,5          | 128,47 | 38x10        | 223,82 |  |
| NPSF 1/4-18 h. | 1    | 13,35 | 11,30    | 70x20x9,0          | 185,64 | 38x10        | 223,82 |  |
| NPSF 3/8-18 h. | 1    | 16,78 | 14,70    | 70x20x9,0          | 256,80 | 45x14        | 284,72 |  |
| NPSF 1/2-14 h. | 1    | 20,87 | 18,20    | 80x22x12,0         | 335,71 | 45x14        | 284,72 |  |
| NPSF 3/4-14 h. | 1    | 26,23 | 23,50    | 90x22x16,0         | 510,79 | 55x16        | 615,45 |  |

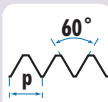
**NPS  
(M)**

**Pas AMÉRICAIN**  
 Filetage Cylindrique  
 Non Étanche

Réf. M0

**HSS**

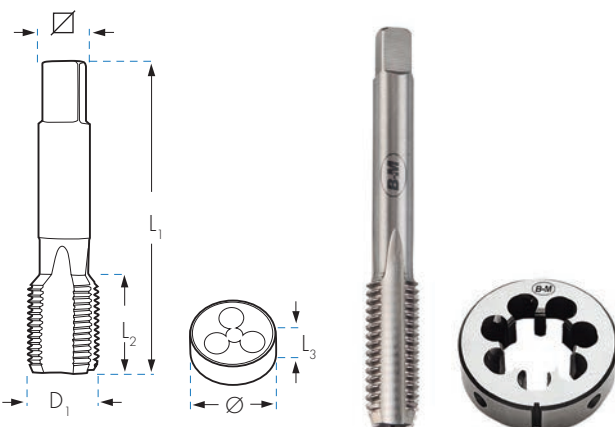
Réf. C5

**HSS**
**DIN  
223**

| Icon           | Icon | Pcs   | D1<br>mm | L1 x L2 x L3<br>mm | M0     |              | C5     |  |
|----------------|------|-------|----------|--------------------|--------|--------------|--------|--|
|                |      |       |          |                    | €      | Ø x L3<br>mm | €      |  |
|                |      |       |          |                    |        |              |        |  |
| NPS 1/8-27 h.  | 1    | 10,20 | 8,9      | 63x18x5,5          | 106,46 | 38x10        | 186,46 |  |
| NPS 1/4-18 h.  | 1    | 13,60 | 11,7     | 70x20x9,0          | 84,72  | 38x10        | 186,46 |  |
| NPS 3/8-18 h.  | 1    | 17,00 | 15,0     | 70x20x9,0          | 117,17 | 45x14        | 237,26 |  |
| NPS 1/2-14 h.  | 1    | 21,20 | 18,6     | 80x22x12,0         | 153,15 | 45x14        | 237,26 |  |
| NPS 3/4-14 h.  | 1    | 26,55 | 24,0     | 90x22x16,0         | 222,42 | 55x16        | 470,01 |  |
| NPS 1"-11,5 h. | 1    | 33,20 | 30,0     | 100x25x20,0        | 311,00 | 65x18        | 473,65 |  |



JEU DE TARAUDS ET FILIÈRES HSS À MAIN

BSPT

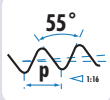

Réf. M0

HSS

DIN  
5157

Réf. C5

HSS

DIN  
223

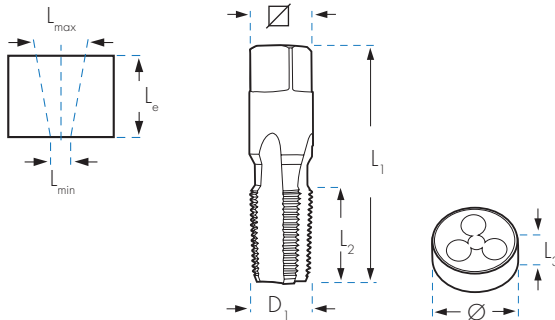

|                |  |     |                      |       |   |                      | M0                                | C5     |                          |        |
|----------------|--|-----|----------------------|-------|---|----------------------|-----------------------------------|--------|--------------------------|--------|
|                |  | Pcs | D <sub>1</sub><br>mm |       | L <sub>min</sub> x L <sub>max</sub><br>mm | L <sub>e</sub><br>mm | L <sub>1</sub> x L <sub>2</sub> x | €      | Ø x L <sub>3</sub><br>mm | €      |
| BSPT 1/8-28 h. |  | 1   | 9,73                 | 8,30  | 8,00 x 8,50                               | 10,1                 | 65 x 19 x 5,5                     | 37,59  | 30 x 11                  | 39,59  |
| BSPT 1/4-19 h. |  | 1   | 13,16                | 11,00 | 10,70 x 11,35                             | 15,0                 | 70 x 25 x 9,0                     | 52,96  | 38 x 14                  | 41,29  |
| BSPT 3/8-19 h. |  | 1   | 16,66                | 14,50 | 14,15 x 14,25                             | 15,4                 | 70 x 25 x 9,0                     | 73,55  | 45 x 16                  | 72,18  |
| BSPT 1/2-14 h. |  | 1   | 20,95                | 18,10 | 17,60 x 18,50                             | 20,5                 | 80 x 31 x 12,0                    | 102,98 | 55 x 22                  | 72,18  |
| BSPT 5/8-14 h. |  | 1   | 22,91                | 20,00 | 19,50 x 20,40                             | 22,4                 | 80 x 36 x 14,5                    | 166,16 | 55 x 19                  | 137,09 |
| BSPT 3/4-14 h. |  | 1   | 26,44                | 23,50 | 23,00 x 24,00                             | 21,8                 | 85 x 33 x 16,0                    | 154,59 | 55 x 22                  | 161,83 |
| BSPT 7/8-14 h. |  | 1   | 30,20                | 27,25 | 26,65 x 28,75                             | 24,0                 | 100 x 36 x 18,0                   | 318,45 | 65 x 22                  | 194,68 |
| BSPT 1"-11 h.  |  | 1   | 33,25                | 29,60 | 29,00 x 30,20                             | 26,0                 | 110 x 38 x 20,0                   | 220,88 | 65 x 25                  | 114,78 |

BA

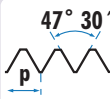

Réf. M0

HSS

DIN  
352

Réf. C5

HSS

DIN  
223

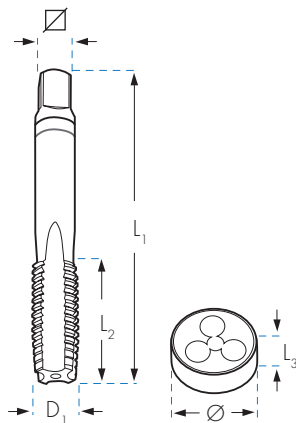

|      |  |      |                      |     |                                   |               | M0                       | C5     |       |
|------|--|------|----------------------|-----|-----------------------------------|---------------|--------------------------|--------|-------|
|      |  | Pcs  | D <sub>1</sub><br>mm |     | L <sub>1</sub> x L <sub>2</sub> x | €             | Ø x L <sub>3</sub><br>mm | €      |       |
| BA-0 |  | 1,00 | 3                    | 6,0 | 5,1                               | 50 x 18 x 4,9 | 186,11                   | 20 x 5 | 90,14 |
| BA-1 |  | 0,90 | 3                    | 5,3 | 4,5                               | 50 x 18 x 4,9 | 186,11                   | 20 x 5 | 90,14 |
| BA-2 |  | 0,81 | 3                    | 4,7 | 4,0                               | 50 x 17 x 4,9 | 186,11                   | 20 x 5 | 90,14 |
| BA-3 |  | 0,73 | 3                    | 4,1 | 3,4                               | 45 x 14 x 3,4 | 200,01                   | 20 x 5 | 90,14 |
| BA-4 |  | 0,66 | 3                    | 3,6 | 3,0                               | 45 x 14 x 3,0 | 200,01                   | 20 x 5 | 90,14 |
| BA-5 |  | 0,59 | 3                    | 3,2 | 2,6                               | 45 x 14 x 3,0 | 238,98                   | 20 x 5 | 90,14 |
| BA-6 |  | 0,53 | 3                    | 2,8 | 2,3                               | 40 x 12 x 2,7 | 238,98                   | 20 x 5 | 90,14 |
| BA-7 |  | 0,48 | 3                    | 2,5 | 2,0                               | 40 x 10 x 2,1 | 262,75                   | 20 x 5 | 90,14 |
| BA-8 |  | 0,43 | 3                    | 2,2 | 1,8                               | 36 x 10 x 2,1 | 262,75                   | 20 x 5 | 90,14 |

## JEUX DE TARAUDS ET FILIÈRES HSS À MAIN

UNx8

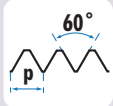

Pas AMÉRICAIN

Réf. M0

HSS

DIN  
2181TOL  
2B

Réf. C5

HSS

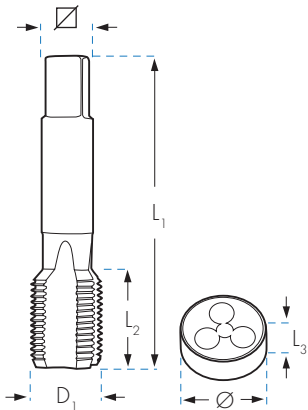
DIN  
223TOL  
2a

| Image | Pcs | D1<br>mm | Ø     | L1 x L2 x<br>mm | M0       |              | C5     |  |
|-------|-----|----------|-------|-----------------|----------|--------------|--------|--|
|       |     |          |       |                 | €        | Ø x L3<br>mm | €      |  |
|       | 2   | 28,57    | 25,40 | 138x65x170      | 357,78   | 65x25        | 377,50 |  |
|       | 2   | 31,75    | 28,50 | 146x65x19,5     | 463,98   | 65x25        | 377,50 |  |
|       | 2   | 34,92    | 31,75 | 154x76x21,0     | 577,09   | 65x25        | 361,79 |  |
|       | 2   | 38,10    | 35,00 | 162x76x23,5     | 660,41   | 75x30        | 409,57 |  |
|       | 2   | 41,27    | 38,10 | 170x80x25,0     | 821,08   | 75x30        | 409,57 |  |
|       | 2   | 44,45    | 41,25 | 178x81x27,0     | 1.023,29 | 90x36        | 477,85 |  |
|       | 2   | 47,62    | 44,45 | 186x90x29,0     | 1.202,73 | 90x36        | 565,36 |  |
|       | 2   | 50,80    | 47,63 | 194x90x31,5     | 1.213,68 | 90x36        | 583,52 |  |
|       | 2   | 57,15    | 54,00 | 208x90x36,0     |          |              |        |  |
|       | 2   | 63,50    | 60,35 | 220x100x36,0    |          |              |        |  |
|       | 2   | 69,85    | 66,70 | 234x104x39,0    |          |              |        |  |
|       | 2   | 76,20    | 73,05 | 248x115x49,0    |          |              |        |  |

UNEF

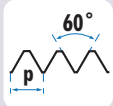

Pas AMÉRICAIN

Réf. M0

HSS

DIN  
2181TOL  
2B

Réf. C5

HSS

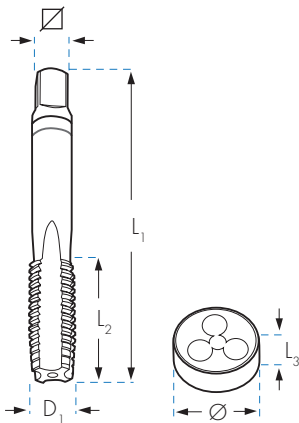
DIN  
223TOL  
2a

| Image | Pcs | D1<br>mm | Ø     | L1 x L2 x<br>mm | M0     |              | C5     |  |
|-------|-----|----------|-------|-----------------|--------|--------------|--------|--|
|       |     |          |       |                 | €      | Ø x L3<br>mm | €      |  |
|       | 2   | 6,35     | 5,55  | 65x28x4,9       | 34,96  | 20x7         | 70,62  |  |
|       | 2   | 7,94     | 7,15  | 70x30x6,0       | 39,06  | 25x9         | 88,22  |  |
|       | 2   | 9,52     | 8,70  | 75x33x7,0       | 43,93  | 30x11        | 99,96  |  |
|       | 2   | 11,11    | 10,20 | 81x38x6,0       | 54,93  | 30x11        | 138,84 |  |
|       | 2   | 12,70    | 11,80 | 86x44x7,0       | 65,43  | 38x10        | 146,84 |  |
|       | 2   | 14,29    | 13,20 | 92x44x8,0       | 63,91  | 38x10        | 146,84 |  |
|       | 2   | 15,87    | 14,80 | 93x47x9,0       | 72,02  | 45x14        | 230,03 |  |
|       | 2   | 19,05    | 17,80 | 108x52x11,0     | 96,18  | 45x14        | 230,03 |  |
|       | 2   | 22,22    | 20,95 | 120x58x13,0     | 130,48 | 55x16        | 274,69 |  |
|       | 2   | 25,40    | 24,20 | 130x65x15,0     | 152,59 | 55x16        | 280,20 |  |

**JEUX DE TARAUDS À MAIN APPLICATIONS SPÉCIALES**

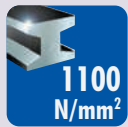

Réf. MOMD

**HSSCo**  
5%

**DIN**  
352

**OX**



SPÉCIAL MATÉRIEAUX DURS  
( ≤ 1100 N/mm<sup>2</sup>=40HRc )

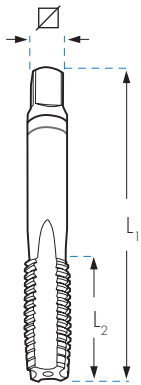

|             |     |       |                                   | MOMD   |  |
|-------------|-----|-------|-----------------------------------|--------|--|
|             | Pcs |       | L <sub>1</sub> x L <sub>2</sub> x | €      |  |
| M 3 x 0,50  | 3   | 2,50  | 40 x 11 x 2,7                     | 37,96  |  |
| M 4 x 0,70  | 3   | 3,30  | 45 x 13 x 3,4                     | 37,96  |  |
| M 5 x 0,80  | 3   | 4,20  | 50 x 17 x 4,9                     | 39,19  |  |
| M 6 x 1,00  | 3   | 5,00  | 50 x 19 x 4,9                     | 40,34  |  |
| M 8 x 1,25  | 3   | 6,80  | 56 x 20 x 4,9                     | 45,86  |  |
| M 10 x 1,50 | 3   | 8,50  | 70 x 22 x 5,5                     | 58,87  |  |
| M 12 x 1,75 | 3   | 10,20 | 75 x 24 x 7,0                     | 84,30  |  |
| M 14 x 2,00 | 3   | 12,00 | 80 x 26 x 9,0                     | 99,78  |  |
| M 16 x 2,00 | 3   | 14,00 | 80 x 27 x 9,0                     | 132,59 |  |
| M 18 x 2,50 | 3   | 15,50 | 95 x 30 x 11,0                    | 203,88 |  |
| M 20 x 2,50 | 3   | 17,50 | 95 x 32 x 12,0                    | 226,37 |  |

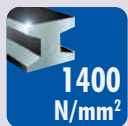

Réf. MOC

**HSS**  
PM

**TiAlSiN**



SPÉCIAL MATÉRIEAUX TRÈS DURS  
( ≤ 1400 N/mm<sup>2</sup>=44HRc )

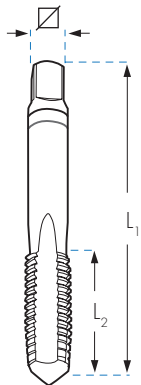

|             |     |       |                                   | MOC    |  |
|-------------|-----|-------|-----------------------------------|--------|--|
|             | Pcs |       | L <sub>1</sub> x L <sub>2</sub> x | €      |  |
| M 3 x 0,50  | 3   | 2,50  | 40 x 11 x 2,7                     | 94,53  |  |
| M 4 x 0,70  | 3   | 3,30  | 45 x 13 x 3,4                     | 101,99 |  |
| M 5 x 0,80  | 3   | 4,20  | 50 x 17 x 4,9                     | 103,27 |  |
| M 6 x 1,00  | 3   | 5,00  | 50 x 19 x 4,9                     | 103,27 |  |
| M 8 x 1,25  | 3   | 6,80  | 56 x 20 x 4,9                     | 116,39 |  |
| M 10 x 1,50 | 3   | 8,50  | 70 x 22 x 5,5                     | 143,86 |  |
| M 12 x 1,75 | 3   | 10,20 | 75 x 24 x 7,0                     | 174,90 |  |
| M 14 x 2,00 | 3   | 12,00 | 80 x 26 x 9,0                     | 214,61 |  |
| M 16 x 2,00 | 3   | 14,00 | 80 x 27 x 9,0                     | 257,13 |  |
| M 18 x 2,50 | 3   | 15,50 | 95 x 30 x 11,0                    | 356,50 |  |
| M 20 x 2,50 | 3   | 17,50 | 95 x 32 x 12,0                    | 392,36 |  |

**Al**

Réf. MOAL

**HSS**

**BRILLANT**



SPÉCIAL ALUMINIUM

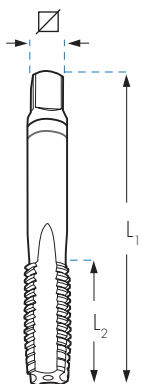

|             |     |       |                                   | MOAL   |  |
|-------------|-----|-------|-----------------------------------|--------|--|
|             | Pcs |       | L <sub>1</sub> x L <sub>2</sub> x | €      |  |
| M 3 x 0,50  | 3   | 2,50  | 40 x 11 x 2,7                     | 29,54  |  |
| M 4 x 0,70  | 3   | 3,30  | 45 x 13 x 3,4                     | 28,68  |  |
| M 5 x 0,80  | 3   | 4,20  | 50 x 17 x 4,9                     | 30,40  |  |
| M 6 x 1,00  | 3   | 5,00  | 50 x 19 x 4,9                     | 30,40  |  |
| M 8 x 1,25  | 3   | 6,80  | 56 x 20 x 4,9                     | 37,32  |  |
| M 10 x 1,50 | 3   | 8,50  | 70 x 22 x 5,5                     | 45,57  |  |
| M 12 x 1,75 | 3   | 10,20 | 75 x 24 x 7,0                     | 64,16  |  |
| M 14 x 2,00 | 3   | 12,00 | 80 x 26 x 9,0                     | 73,73  |  |
| M 16 x 2,00 | 3   | 14,00 | 80 x 27 x 9,0                     | 104,65 |  |
| M 18 x 2,50 | 3   | 15,50 | 95 x 30 x 11,0                    | 138,70 |  |
| M 20 x 2,50 | 3   | 17,50 | 95 x 32 x 12,0                    | 156,36 |  |

## JEUX DE TARAUDS À MAIN ET FILIÈRES POUR INOX

M

INOX

Réf. MOT  
Réf. MOXDIN  
352TOL  
6H

TiN

Réf. CST  
Réf. CSXDIN  
223TOL  
6g

OX

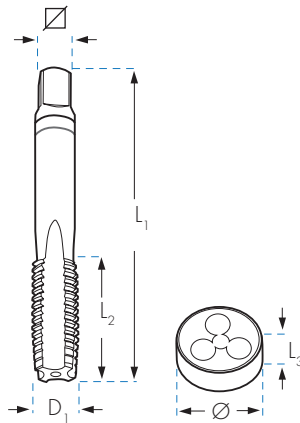

|   |   | Pcs              | L <sub>1</sub> x L <sub>2</sub> x $\nabla$<br>mm | MOT   | CST    | MOX   | CSX     | Ø x L <sub>3</sub><br>mm |
|---|---|------------------|--|-------|--------|-------|---------|--------------------------|
|   |   |                  |  | HSS   | HSS    | HSSCo | HSSCo   |                          |
|   |   |                  |  | TiN   | TiN    | OX    | OX      |                          |
|  |   |                  |  | €     | €      | €     | €       |                          |
| M 3 x 0,50  | 3 | 40 x 11 x 2,70   | 27,68  | 25,02 | 28,55  | 27,32 | 20 x 5  |                          |
| M 4 x 0,70  | 3 | 45 x 13 x 3,40   | 29,65  | 26,18 | 28,55  | 27,32 | 20 x 5  |                          |
| M 5 x 0,80  | 3 | 50 x 16 x 4,90   | 34,59  | 26,18 | 28,96  | 26,05 | 20 x 7  |                          |
| M 6 x 1,00  | 3 | 50 x 19 x 4,90   | 34,59  | 26,18 | 28,88  | 26,03 | 20 x 7  |                          |
| M 8 x 1,00  | 2 | 50 x 19 x 4,90   | 34,82  |       |        |       |         |                          |
| M 8 x 1,25  | 3 | 56 x 22 x 4,90   | 42,99  | 26,83 | 33,17  | 33,92 | 25 x 9  |                          |
| M 10 x 1,00   | 2 | 63 x 18 x 5,50   | 40,18  |       |        |       |         |                          |
| M 10 x 1,50   | 3 | 70 x 24 x 5,50   | 50,37  | 33,66 | 44,36  | 45,40 | 30 x 11 |                          |
| M 12 x 1,50   | 2 | 70 x 20 x 7,00   | 51,15  |       |        |       |         |                          |
| M 12 x 1,75   | 3 | 75 x 29 x 7,00   | 54,22  | 48,60 | 57,90  | 67,18 | 38 x 14 |                          |
| M 14 x 1,50   | 2 | 70 x 20 x 9,00   | 59,49  |       |        |       |         |                          |
| M 14 x 2,00   | 3 | 80 x 30 x 9,00   | 79,82  | 53,81 | 73,02  | 67,18 | 38 x 14 |                          |
| M 16 x 2,00   | 3 | 80 x 32 x 9,00   | 87,11  | 68,43 | 89,08  | 97,17 | 45 x 18 |                          |
| M 18 x 2,50   | 3 | 95 x 40 x 11,00  | 91,96  |       | 116,68 |       |         |                          |
| M 20 x 2,50   | 3 | 95 x 40 x 12,00  | 98,48  |       | 131,36 |       |         |                          |
| M 22 x 2,50   | 3 | 100 x 40 x 14,50 | 124,58   |       |        |       |         |                          |
| M 24 x 3,00   | 3 | 110 x 50 x 14,50 | 162,01   |       |        |       |         |                          |

M

FILIÈRES HEXAGONALES EN HSS

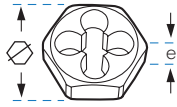

**M** HSS DIN 382

|                    |  | C5HM    |        |
|--------------------|--|---------|--------|
|                    |  |         | €      |
| M 3 x 0,35         |  | 18 x 5  | 38,35  |
| <b>M 3 x 0,50</b>  |  | 19 x 5  | 24,95  |
| M 3,5 x 0,60       |  | 18 x 5  | 38,35  |
| M 4 x 0,50         |  | 18 x 5  | 38,35  |
| <b>M 4 x 0,70</b>  |  | 19 x 5  | 23,39  |
| M 5 x 0,50         |  | 18 x 5  | 38,35  |
| M 5 x 0,75         |  | 18 x 5  | 38,35  |
| <b>M 5 x 0,80</b>  |  | 19 x 7  | 23,39  |
| M 6 x 0,75         |  | 18 x 7  | 42,06  |
| <b>M 6 x 1,00</b>  |  | 19 x 7  | 24,95  |
| M 7 x 0,75         |  | 21 x 9  | 40,77  |
| M 7 x 1,00         |  | 21 x 9  | 26,46  |
| M 8 x 0,75         |  | 21 x 9  | 44,49  |
| M 8 x 1,00         |  | 21 x 9  | 44,49  |
| <b>M 8 x 1,25</b>  |  | 22 x 9  | 26,46  |
| M 9 x 0,75         |  | 21 x 9  | 47,98  |
| M 9 x 1,00         |  | 21 x 9  | 47,98  |
| <b>M 9 x 1,25</b>  |  | 22 x 9  | 47,98  |
| M 10 x 1,00        |  | 27 x 11 | 44,47  |
| M 10 x 1,25        |  | 27 x 11 | 44,47  |
| <b>M 10 x 1,50</b> |  | 27 x 11 | 30,42  |
| M 11 x 1,00        |  | 27 x 11 | 79,95  |
| M 11 x 1,50        |  | 27 x 11 | 79,95  |
| M 12 x 1,25        |  | 36 x 10 | 59,51  |
| M 12 x 1,50        |  | 36 x 10 | 59,51  |
| <b>M 12 x 1,75</b> |  | 36 x 10 | 39,92  |
| M 14 x 1,25        |  | 36 x 14 | 66,50  |
| M 14 x 1,50        |  | 36 x 10 | 66,50  |
| <b>M 14 x 2,00</b> |  | 36 x 10 | 39,92  |
| M 15 x 1,00        |  | 36 x 14 | 105,37 |
| M 15 x 1,50        |  | 41 x 14 | 105,37 |
| M 16 x 1,00        |  | 41 x 14 | 80,51  |
| M 16 x 1,50        |  | 41 x 14 | 80,51  |

|                    |  | C5HM    |        |
|--------------------|--|---------|--------|
|                    |  |         | €      |
| M 16 x 2,00        |  | 41 x 18 | 54,23  |
| M 18 x 1,00        |  | 41 x 14 | 105,37 |
| M 18 x 1,50        |  | 41 x 14 | 84,70  |
| <b>M 18 x 2,50</b> |  | 41 x 18 | 54,23  |
| M 20 x 1,00        |  | 41 x 14 | 105,37 |
| M 20 x 1,50        |  | 41 x 14 | 84,70  |
| M 20 x 2,00        |  | 41 x 18 | 105,37 |
| <b>M 20 x 2,50</b> |  | 41 x 18 | 54,23  |
| M 22 x 1,00        |  | 50 x 16 | 119,96 |
| M 22 x 1,50        |  | 50 x 16 | 119,96 |
| M 22 x 2,00        |  | 50 x 16 | 119,96 |
| <b>M 22 x 2,50</b> |  | 50 x 16 | 87,12  |
| M 24 x 1,00        |  | 50 x 16 | 119,96 |
| M 24 x 1,50        |  | 50 x 16 | 119,96 |
| M 24 x 2,00        |  | 50 x 16 | 119,96 |
| <b>M 24 x 3,00</b> |  | 50 x 22 | 105,27 |
| M 27 x 1,50        |  | 60 x 18 | 180,14 |
| M 27 x 2,00        |  | 60 x 18 | 180,14 |
| <b>M 27 x 3,00</b> |  | 60 x 25 | 155,16 |
| M 30 x 1,00        |  | 60 x 18 | 180,14 |
| M 30 x 1,50        |  | 60 x 18 | 180,14 |
| M 30 x 2,00        |  | 60 x 18 | 177,55 |
| M 30 x 3,00        |  | 60 x 18 | 180,14 |
| <b>M 30 x 3,50</b> |  | 60 x 25 | 155,16 |
| M 33 x 1,50        |  | 60 x 18 | 201,70 |
| M 33 x 2,00        |  | 60 x 18 | 201,70 |
| <b>M 33 x 3,50</b> |  | 60 x 25 | 173,11 |
| M 35 x 1,50        |  | 60 x 18 | 192,26 |
| M 36 x 1,50        |  | 60 x 18 | 192,26 |
| M 36 x 2,00        |  | 60 x 18 | 192,26 |
| M 36 x 3,00        |  | 60 x 18 | 192,26 |
| <b>M 36 x 4,00</b> |  | 60 x 25 | 160,22 |

**BSW** HSS DIN 382

|                 |  | C5HW    |       |
|-----------------|--|---------|-------|
|                 |  |         | €     |
| BSW 1/8 x 40h.  |  | 19 x 5  | 44,36 |
| BSW 3/16 x 24h. |  | 19 x 7  | 44,36 |
| BSW 1/4 x 20h.  |  | 19 x 7  | 44,36 |
| BSW 5/16 x 18h. |  | 22 x 9  | 46,57 |
| BSW 3/8 x 16h.  |  | 27 x 11 | 55,44 |
| BSW 7/16 x 14h. |  | 27 x 11 | 55,44 |
| BSW 1/2 x 12h.  |  | 36 x 14 | 66,55 |

|                 |  | C5HW    |        |
|-----------------|--|---------|--------|
|                 |  |         | €      |
| BSW 9/16 x 12h. |  | 36 x 14 | 66,55  |
| BSW 5/8 x 11h.  |  | 41 x 18 | 98,35  |
| BSW 3/4 x 10h.  |  | 41 x 18 | 98,35  |
| BSW 7/8 x 9h.   |  | 50 x 22 | 144,13 |
| BSW 1" x 8h.    |  | 50 x 22 | 144,13 |
| BSW 1.1/8 x 7h. |  | 60 x 25 | 248,43 |

**BSP (GAS)** HSS DIN 382

|               |  | C5HG     |        |
|---------------|--|----------|--------|
|               |  |          | €      |
| G 1/8 x 28h.  |  | 27 x 11  | 78,08  |
| G 1/4 x 19h.  |  | 36 x 10  | 78,08  |
| G 3/8 x 19h.  |  | 41 x 14  | 97,63  |
| G 1/2 x 14h.  |  | 41 x 14  | 97,63  |
| G 5/8 x 14h.  |  | 50 x 16  | 229,88 |
| G 3/4 x 14h.  |  | 50 x 16  | 229,88 |
| G 7/8 x 14h.  |  | 60 x 18  | 231,94 |
| G 1" x 11h.   |  | 60 x 18  | 231,94 |
| G1.1/4 x 11h. |  | 70 x 20  | 309,23 |
| G1.1/2 x 11h. |  | 85 x 22  | 521,71 |
| G 2" x 11h.   |  | 100 x 22 | 785,04 |

**UNC** HSS DIN 382

|              |  | C5HNC   |        |
|--------------|--|---------|--------|
|              |  |         | €      |
| UNC 1/4-20h  |  | 18 x 7  | 32,34  |
| UNC 5/16-18h |  | 21 x 9  | 40,25  |
| UNC 3/8-16h  |  | 27 x 11 | 48,56  |
| UNC 7/16-14h |  | 27 x 11 | 71,67  |
| UNC 1/2-13h  |  | 36 x 14 | 71,93  |
| UNC 9/16-12h |  | 36 x 14 | 85,96  |
| UNC 5/8-11h  |  | 41 x 18 | 66,61  |
| UNC 3/4-10h  |  | 41 x 18 | 105,96 |
| UNC 7/8-9h   |  | 50 x 22 | 150,36 |
| UNC 1"-8h    |  | 50 x 22 | 150,36 |
| UNC 1.1/8-7h |  | 60 x 25 | 198,77 |
| UNC 1.1/4-7h |  | 60 x 25 | 198,77 |

**UNF** HSS DIN 382

|               |  | C5HNF   |        |
|---------------|--|---------|--------|
|               |  |         | €      |
| UNF 1/4-28h.  |  | 18 x 7  | 34,27  |
| UNF 5/16-24h. |  | 21 x 9  | 42,86  |
| UNF 3/8-24h.  |  | 27 x 11 | 51,54  |
| UNF 7/16-20h. |  | 27 x 11 | 75,96  |
| UNF 1/2-20h.  |  | 36 x 10 | 77,13  |
| UNF 9/16-18h. |  | 36 x 10 | 85,96  |
| UNF 5/8-18h.  |  | 41 x 14 | 107,25 |
| UNF 3/4-16h   |  | 41 x 14 | 112,31 |
| UNF 7/8-14h   |  | 50 x 16 | 142,05 |
| UNF 1"-12h    |  | 50 x 16 | 148,92 |
| UNS 1"-14h    |  | 50 x 16 | 148,92 |
| UNF 1.1/8-12h |  | 60 x 18 | 198,77 |
| UNF 1.1/4-12h |  | 60 x 18 | 198,77 |

Taroucs et filières  
Rose

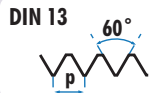
**JEUX DE TARAUDS ET FILIÈRES À MAIN, À GAUCHE**

Réf. MOI

HSS

(M)

DIN 352

(MF)

DIN 2181

TOL 6H

Réf. CSI

HSS

DIN 223

TOL 6g

Pour matières jusque 38 HRC



GAUCHE

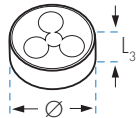
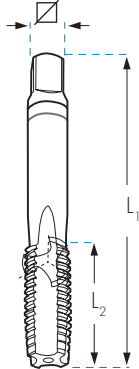

|           | Pcs. | D1 mm | L1 x L2 x L3 mm | MOI    |           | CSI    |   |
|-----------|------|-------|-----------------|--------|-----------|--------|---|
|           |      |       |                 | €      | Ø x L3 mm | €      | € |
| M 2x0,40  | 3    | 1,60  | 36x9,0x2,1      | 58,26  | 16x5      | 57,58  |   |
| M 3x0,50  | 3    | 2,50  | 40x11,0x2,7     | 29,72  | 25x9      | 33,56  |   |
| M 4x0,70  | 3    | 3,30  | 45x13,0x3,4     | 29,70  | 25x9      | 33,56  |   |
| M 5x0,80  | 3    | 4,20  | 50x16,0x4,9     | 34,92  | 25x9      | 34,60  |   |
| M 6x1,00  | 3    | 5,00  | 50x19x4,9       | 34,92  | 25x9      | 34,05  |   |
| M 7x1,00  | 3    | 6,00  | 50x19x4,9       | 44,18  | 25x9      | 48,10  |   |
| M 8x1,00  | 2    | 7,00  | 56x18x4,9       | 45,77  | 25x9      | 52,45  |   |
| M 8x1,25  | 3    | 6,80  | 56x22x4,9       | 46,22  | 25x9      | 37,21  |   |
| M 9x1,25  | 3    | 7,80  | 63x22x5,5       | 49,74  | 25x9      | 54,93  |   |
| M 10x1,50 | 3    | 8,50  | 70x24x5,5       | 50,14  | 38x10     | 42,57  |   |
| M 12x1,50 | 2    | 10,50 | 70x20x7,0       | 73,86  | 38x10     | 72,04  |   |
| M 12x1,75 | 3    | 10,20 | 75x29x7,0       | 66,07  | 38x14     | 57,60  |   |
| M 14x1,25 | 2    | 12,80 | 70x20x9,0       | 93,05  | 38x10     | 83,25  |   |
| M 14x2,00 | 3    | 12,00 | 80x30x9,0       | 88,98  | 38x14     | 64,62  |   |
| M 16x1,50 | 2    | 14,50 | 70x20x9,0       | 98,03  | 45x14     | 98,73  |   |
| M 16x2,00 | 3    | 14,00 | 80x32x9,0       | 110,64 | 45x18     | 75,77  |   |
| M 18x2,00 | 2    | 16,00 | 80x22x11,0      | 148,17 | 45x14     | 116,68 |   |
| M 18x2,50 | 3    | 15,50 | 95x40x11,0      | 121,97 | 45x18     | 86,05  |   |
| M 20x2,00 | 2    | 18,00 | 80x22x12,0      | 190,46 | 45x14     | 113,57 |   |
| M 20x2,50 | 3    | 17,50 | 95x40x12,0      | 134,62 | 45x18     | 86,05  |   |
| M 22x2,00 | 2    | 20,00 | 80x22x14,5      | 184,78 | 55x16     | 176,21 |   |
| M 22x2,50 | 3    | 19,50 | 100x40x14,5     | 188,28 | 55x22     | 153,13 |   |
| M 24x2,00 | 2    | 22,00 | 90x22x14,5      | 251,77 | 55x16     | 176,21 |   |
| M 24x3,00 | 3    | 21,00 | 110x50x14,5     | 242,40 | 55x22     | 153,13 |   |
| M 27x2,00 | 2    | 25,00 | 90x22x16,0      | 450,99 | 65x18     | 256,48 |   |
| M 27x3,00 | 3    | 24,00 | 110x50x16,0     | 338,08 | 65x25     | 181,41 |   |
| M 30x3,00 | 2    | 27,00 | 125x56x18,0     | 478,08 | 65x25     | 263,77 |   |
| M 30x3,50 | 3    | 26,50 | 125x50x18,0     | 423,36 | 65x25     | 214,88 |   |
| M 33x2,00 | 2    | 31,00 | 100x25x20,0     | 727,08 | 65x18     | 263,77 |   |
| M 33x3,50 | 3    | 29,50 | 125x50x20,0     | 619,00 | 65x25     | 214,86 |   |
| M 36x3,00 | 2    | 33,00 | 125x33x22,0     | 838,74 | 65x25     | 256,46 |   |
| M 36x4,00 | 3    | 32,00 | 150x53x22,0     | 853,19 | 65x25     | 214,88 |   |
| M 39x3,00 | 2    | 36,00 | 125x33x24,0     | 943,85 | 75x30     | 401,78 |   |
| M 39x4,00 | 3    | 35,00 | 150x53x24,0     | 965,56 | 75x30     | 333,01 |   |

Autres dimensions disponibles sur demande

**UNC**

|               | Pcs. | D1 mm | L1 x L2 x L3 mm | MOI         |           | CSI   |        |
|---------------|------|-------|-----------------|-------------|-----------|-------|--------|
|               |      |       |                 | €           | Ø x L3 mm | €     | €      |
| UNC 1/4-20h.  | 3    | 6,35  | 5,10            | 50x19x4,9   | 60,29     | 20x7  | 60,12  |
| UNC 5/16-18h. | 3    | 7,94  | 6,60            | 56x22x4,9   | 66,40     | 25x9  | 66,61  |
| UNC 3/8-16h.  | 3    | 9,52  | 8,00            | 70x24x5,5   | 74,33     | 30x11 | 70,26  |
| UNC 1/2-13h.  | 3    | 12,70 | 10,75           | 75x29x7,0   | 123,72    | 38x14 | 90,18  |
| UNC 5/8-11h.  | 3    | 15,87 | 13,50           | 80x32x9,0   | 165,49    | 45x18 | 99,22  |
| UNC 3/4-10h.  | 3    | 19,05 | 16,50           | 95x40x11,0  | 219,61    | 45x18 | 116,47 |
| UNC 1"-8h.    | 3    | 25,40 | 22,25           | 110x50x14,5 | 325,95    | 55x22 | 172,76 |

**UNF**

|               | Pcs. | D1 mm | L1 x L2 x L3 mm | MOI        |           | CSI   |        |
|---------------|------|-------|-----------------|------------|-----------|-------|--------|
|               |      |       |                 | €          | Ø x L3 mm | €     | €      |
| UNF 1/4-28h.  | 2    | 6,35  | 5,50            | 50x14x4,9  | 41,21     | 25x9  | 60,12  |
| UNF 5/16-24h. | 2    | 7,94  | 6,90            | 56x22x4,9  | 40,89     | 25x9  | 66,63  |
| UNF 3/8-24h.  | 2    | 9,52  | 8,50            | 63x20x5,5  | 59,21     | 38x10 | 69,13  |
| UNF 1/2-20h.  | 2    | 12,70 | 11,50           | 70x22x7,0  | 73,27     | 38x10 | 90,18  |
| UNF 5/8-18h.  | 2    | 15,87 | 14,50           | 70x22x9,0  | 102,76    | 45x14 | 99,22  |
| UNF 3/4-16h.  | 2    | 19,05 | 17,50           | 80x22x11,0 | 133,43    | 45x14 | 116,47 |
| UNS 1"-14h.   | 2    | 25,40 | 23,60           | 90x22x14,5 | 296,97    | 55x16 | 225,38 |

**BSP (GAS)**

|              | Pcs. | D1 mm | L1 x L2 x L3 mm | MOI             |           | CSI   |        |
|--------------|------|-------|-----------------|-----------------|-----------|-------|--------|
|              |      |       |                 | €               | Ø x L3 mm | €     | €      |
| G 1/8-28h.   | 2    | 9,73  | 8,80            | 63 x 20 x 5,5   | 61,93     | 38x10 | 83,74  |
| G 1/4-19h.   | 2    | 13,16 | 11,80           | 70 x 22 x 9,0   | 66,14     | 38x10 | 85,90  |
| G 3/8-19h.   | 2    | 16,66 | 15,25           | 70 x 22 x 9,0   | 96,86     | 45x14 | 106,23 |
| G 1/2-14h.   | 2    | 20,95 | 19,00           | 80 x 22 x 12,0  | 160,12    | 45x14 | 106,23 |
| G 5/8-14h.   | 2    | 22,91 | 21,00           | 80 x 22 x 14,5  | 200,72    | 55x16 | 168,52 |
| G 3/4-14h.   | 2    | 26,44 | 24,50           | 90 x 22 x 16,0  | 231,06    | 55x16 | 168,50 |
| G 1"-11h.    | 2    | 33,25 | 30,75           | 100 x 25 x 20,0 | 332,99    | 65x18 | 216,69 |
| G 1.1/4-11h. | 2    | 41,91 | 39,50           | 125 x 40 x 24,0 | 535,66    | 75x20 | 334,77 |

**BSW**

|             | Pcs. | D1 mm | L1 x L2 x L3 mm | MOI         |           | CSI   |        |
|-------------|------|-------|-----------------|-------------|-----------|-------|--------|
|             |      |       |                 | €           | Ø x L3 mm | €     | €      |
| W 1/8-40h.  | 3    | 3,17  | 2,55            | 40x14x2,7   | 60,14     | 25x9  | 60,12  |
| W 1/4-20h.  | 3    | 6,35  | 5,10            | 50x20x4,9   | 56,92     | 25x9  | 60,12  |
| W 5/16-18h. | 3    | 7,94  | 6,50            | 56x20x4,9   | 66,21     | 25x9  | 66,63  |
| W 3/8-16h.  | 3    | 9,52  | 7,90            | 63x22x5,5   | 81,85     | 38x10 | 71,97  |
| W 5/8-11h.  | 3    | 15,87 | 13,40           | 80x27x9,0   | 157,77    | 45x18 | 108,99 |
| W 3/4-10h.  | 3    | 19,05 | 16,50           | 95x32x11,0  | 209,99    | 45x18 | 116,52 |
| W 7/8-9h.   | 3    | 22,22 | 19,25           | 100x32x14,5 | 258,89    | 55x22 | 172,74 |
| W 1"-8h.    | 3    | 25,40 | 21,75           | 110x36x14,5 | 424,70    | 55x22 | 172,74 |

**TARAUD FINISSEUR, PAS MÉTRIQUE, À GAUCHE ET À DROITE**

**M  
MF**

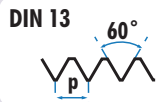

**HSS**

**DIN  
352**

**TOL  
6H**

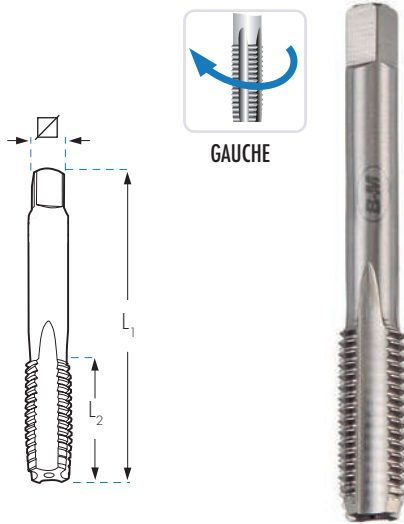

**GAUCHE**

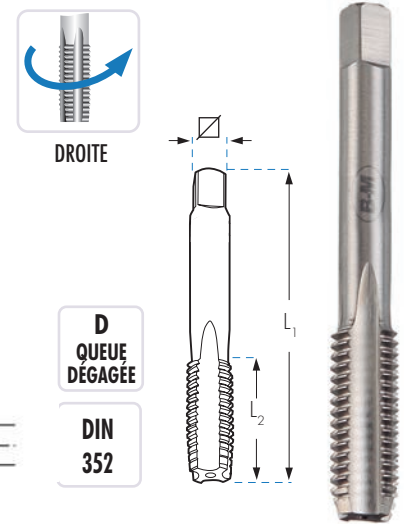

**DROITE**

**D  
QUEUE  
DÉGAGÉE**

**DIN  
352**

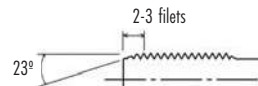

Réf. M03: Entrée 2-3 filets

|           |       |  |  | M03I  |
|-----------|-------|--|--|-------|
|           |       | $L_1 \times L_2 \times D_2 \times \square$ |  | €     |
|           |       | mm   |  |       |
| M 3x0,50  | 2,50  | D 40 x 11 x 3,50 x 2,70                    |  | 9,91  |
| M 4x0,70  | 3,30  | D 45 x 13 x 4,50 x 3,40                    |  | 9,90  |
| M 5x0,80  | 4,20  | D 50 x 16 x 6,00 x 4,90                    |  | 11,64 |
| M 6x1,00  | 5,00  | D 50 x 19 x 6,00 x 4,90                    |  | 11,64 |
| M 7x1,00  | 6,00  | D 50 x 19 x 6,00 x 4,90                    |  | 14,73 |
| M 8x1,25  | 6,75  | D 56 x 22 x 6,00 x 4,90                    |  | 15,41 |
| M 10x1,50 | 8,50  | D 70 x 24 x 7,00 x 5,50                    |  | 16,71 |
| M 12x1,75 | 10,20 | D 75 x 29 x 9,00 x 7,00                    |  | 22,02 |
| M 14x2,00 | 12,00 | D 80 x 30 x 11,00 x 9,00                   |  | 29,66 |
| M 16x2,00 | 14,00 | D 80 x 32 x 12,00 x 9,00                   |  | 36,88 |
| M 18x2,50 | 15,50 | D 95 x 40 x 14,00 x 11,00                  |  | 40,66 |
| M 20x2,50 | 17,50 | D 95 x 40 x 16,00 x 12,00                  |  | 44,87 |

Autres dimensions disponibles sur demande

|           |       |  |  | M03   |
|-----------|-------|--|--|-------|
|           |       | $L_1 \times L_2 \times D_2 \times \square$ |  | €     |
|           |       | mm   |  |       |
| M 3x0,50  | 2,50  | D 40 x 11 x 3,50 x 2,70                    |  | 4,95  |
| M 4x0,70  | 3,30  | D 45 x 13 x 4,50 x 3,40                    |  | 4,95  |
| M 5x0,80  | 4,20  | D 50 x 16 x 6,00 x 4,90                    |  | 5,82  |
| M 6x1,00  | 5,00  | D 50 x 19 x 6,00 x 4,90                    |  | 5,82  |
| M 7x1,00  | 6,00  | D 50 x 19 x 6,00 x 4,90                    |  | 7,36  |
| M 8x1,00  | 7,00  | D 56 x 18 x 6,00 x 4,90                    |  | 11,44 |
| M 8x1,25  | 6,75  | D 56 x 22 x 6,00 x 4,90                    |  | 7,70  |
| M 9x1,25  | 7,75  | D 63 x 18 x 7,00 x 5,50                    |  | 8,29  |
| M 10x1,00 | 9,00  | D 63 x 18 x 7,00 x 5,50                    |  | 12,26 |
| M 10x1,25 | 8,80  | D 70 x 24 x 7,00 x 5,50                    |  | 12,54 |
| M 10x1,50 | 8,50  | D 70 x 24 x 7,00 x 5,50                    |  | 8,36  |
| M 12x1,00 | 11,00 | D 70 x 20 x 9,00 x 7,00                    |  | 20,08 |
| M 12x1,25 | 10,75 | D 70 x 20 x 9,00 x 7,00                    |  | 20,02 |
| M 12x1,50 | 10,50 | D 70 x 20 x 9,00 x 7,00                    |  | 18,47 |
| M 12x1,75 | 10,20 | D 75 x 29 x 9,00 x 7,00                    |  | 11,01 |
| M 14x1,00 | 13,00 | D 70 x 20 x 11,00 x 9,00                   |  | 31,18 |
| M 14x1,25 | 12,80 | D 70 x 20 x 11,00 x 9,00                   |  | 23,26 |
| M 14x1,50 | 12,50 | D 70 x 20 x 11,00 x 9,00                   |  | 19,92 |
| M 14x2,00 | 12,00 | D 80 x 30 x 11,00 x 9,00                   |  | 14,83 |
| M 16x1,00 | 15,00 | D 70 x 20 x 12,00 x 9,00                   |  | 34,01 |
| M 16x1,25 | 14,75 | D 70 x 20 x 12,00 x 9,00                   |  | 34,22 |
| M 16x1,50 | 14,50 | D 70 x 20 x 12,00 x 9,00                   |  | 24,51 |
| M 16x2,00 | 14,00 | D 80 x 32 x 12,00 x 9,00                   |  | 18,44 |
| M 18x1,50 | 16,50 | D 80 x 22 x 14,00 x 11,00                  |  | 27,78 |
| M 18x2,50 | 15,50 | D 95 x 40 x 14,00 x 11,00                  |  | 20,33 |
| M 20x1,50 | 18,50 | D 80 x 22 x 16,00 x 12,00                  |  | 33,85 |
| M 20x2,50 | 17,50 | D 95 x 40 x 16,00 x 12,00                  |  | 22,44 |
| M 22x2,50 | 19,50 | D 100 x 40 x 18,00 x 14,50                 |  | 31,38 |
| M 24x3,00 | 21,00 | D 110 x 50 x 18,00 x 14,50                 |  | 40,40 |
| M 27x3,00 | 24,00 | D 110 x 50 x 20,00 x 16,00                 |  | 56,35 |
| M 30x3,50 | 26,50 | D 125 x 50 x 22,00 x 18,00                 |  | 70,56 |

## JAUGE DE CONTRÔLE DE FILETAGE



|      | TYPE DE PAS                | FOURCHETTE DE PAS |          | GAM   |
|------|----------------------------|-------------------|----------|-------|
|      |                            | Métrique          | Anglais  | €     |
| GAM  | Pas métrique               | 0,25 - 2,5        |          | 12,39 |
| GAMW | Pas métrique / Pas anglais | 0,25 - 6,0        | 62h - 4h | 17,06 |

## ENSEMBLE DE GUIDES POUR FILIÈRES M3-M12



CG5  
M3-M12  
**14,42 €**

## RALLONGES POUR TARAUDS

DIN  
377

DIN 10

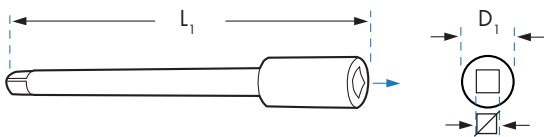

Même dimension de carré pour la partie mâle et pour la partie femelle

|      | $\square \times L_1$<br>mm | $D_1$ | AL<br>€ |
|------|----------------------------|-------|---------|
| AL21 | 2,1 x 60                   | 6,0   | 8,46    |
| AL24 | 2,4 x 70                   | 6,0   | 8,46    |
| AL27 | 2,7 x 80                   | 7,0   | 8,46    |
| AL30 | 3,0 x 90                   | 7,0   | 8,46    |
| AL34 | 3,4 x 95                   | 8,0   | 9,18    |
| AL38 | 3,8 x 95                   | 9,0   | 9,58    |
| AL43 | 4,3 x 105                  | 10,0  | 10,67   |
| AL49 | 4,9 x 110                  | 11,0  | 10,78   |
| AL55 | 5,5 x 115                  | 12,0  | 10,85   |
| AL62 | 6,2 x 120                  | 14,0  | 13,10   |
| AL70 | 7,0 x 125                  | 15,0  | 13,64   |
| AL80 | 8,0 x 125                  | 17,0  | 17,04   |
| AL90 | 9,0 x 135                  | 19,0  | 17,50   |

|       | $\square \times L_1$<br>mm | $D_1$ | AL<br>€ |
|-------|----------------------------|-------|---------|
| AL100 | 10,0 x 140                 | 21,0  | 17,11   |
| AL110 | 11,0 x 150                 | 23,0  | 20,85   |
| AL120 | 12,0 x 160                 | 25,0  | 26,42   |
| AL130 | 13,0 x 165                 | 27,0  | 41,32   |
| AL145 | 14,5 x 175                 | 29,0  | 41,89   |
| AL160 | 16,0 x 185                 | 30,0  | 44,32   |
| AL180 | 18,0 x 195                 | 33,0  | 50,51   |
| AL200 | 20,0 x 220                 | 36,0  | 67,35   |
| AL220 | 22,0 x 220                 | 40,0  | 98,44   |
| AL240 | 24,0 x 235                 | 42,0  | 146,67  |
| AL260 | 26,0 x 245                 | 45,0  | 159,37  |
| AL290 | 29,0 x 260                 | 55,0  | 183,66  |
| AL320 | 32,0 x 280                 | 55,0  | 230,45  |



**TOURNE À GAUCHE ACIER FORGÉ ANTI-CASSE**

Résistance  
Max  
150 kg/mm<sup>2</sup>

Réf. GAPRO

- Corps en Acier Forgé.
- Supporte les efforts jusque 150kg/mm<sup>2</sup>
- Résistance et Durabilité Maximales

- Plus grandes précision et fermeté dans l'attache
- Son filetage de précision forme un ensemble solide et robuste
- Poignée anti-glisse pour un grip amélioré dans l'atelier.



GAPRO

| N° NORME | N° 0               | N° 1                | N° 1.1/2            | N° 2                | N° 3                 | N° 4                 | N° 5                 |
|----------|--------------------|---------------------|---------------------|---------------------|----------------------|----------------------|----------------------|
|          | M1-M8<br>2,00-5,00 | M1-M10<br>2,00-6,30 | M1-M12<br>2,50-7,00 | M1-M12<br>2,50-8,00 | M5-M20<br>4,00-13,00 | M5-M27<br>4,00-16,00 | M9-M32<br>5,50-20,00 |
| €        | 16,96              | 17,94               | 23,82               | 30,08               | 42,58                | 68,09                | 144,10               |

Réf. GA

- Corps en alliage de zinc
- Résistance et durabilité élevées
- Hautes précision et fermeté de l'attache



GA

| N° NORME | N° 0               | N° 1                | N° 1.1/2            | N° 2                 | N° 3                 | N° 4                 | N° 5                  | N° 7                   | N° 8                   |
|----------|--------------------|---------------------|---------------------|----------------------|----------------------|----------------------|-----------------------|------------------------|------------------------|
|          | M1-M8<br>1,50-5,00 | M1-M10<br>2,00-7,00 | M1-M12<br>2,00-8,00 | M4-M12<br>2,50-10,00 | M5-M20<br>3,50-14,00 | M9-M27<br>4,00-15,00 | M13-M32<br>5,50-19,00 | M22-M52<br>14,00-34,00 | M33-M64<br>16,00-40,00 |
| €        | 12,30              | 14,88               | 20,00               | 25,28                | 35,79                | 57,22                | 121,09                | 241,52                 | 395,76                 |

**PORTE-FILIÈRES DE 5 VIS DIN 225**

Réf. VA

**DIN  
225**



**IMPORTANT:** Au moment de la commande, vous devez indiquer l'épaisseur du porte-filières selon les épaisseurs des filières indiquées au tarif.

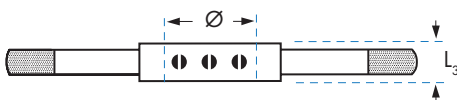

| Ø x L3 mm | 16x5  | 20x5  | 20x7  | 25x9   | 30x11  | 38x10  | 38x14  | 45x14  | 45x18  | 55x16  | 55x22  | 65x18 | 65x25 |
|-----------|-------|-------|-------|--------|--------|--------|--------|--------|--------|--------|--------|-------|-------|
| €         | 9,88  | 10,95 | 10,95 | 12,51  | 15,13  | 19,80  | 19,78  | 24,30  | 24,49  | 31,42  | 32,91  | 45,02 | 45,02 |
| Ø x L3 mm | 75x20 | 75x30 | 90x22 | 90x36  | 105x22 | 105x36 | 120x22 | 120x36 | 130x25 | 130x36 | 140x25 |       |       |
| €         | 77,99 | 81,64 | 98,80 | 106,45 | 148,42 | 148,42 | 385,99 | 385,99 | 401,28 | 401,28 | 421,98 |       |       |

VA

Réf. VA

**POUCES**



| Ø mm      | 20,60  | 25,40 | 38,10  | 50,80 | 63,50  | 76,20 | 88,90  |
|-----------|--------|-------|--------|-------|--------|-------|--------|
| En pouces | 13/16" | 1"    | 1.1/2" | 2"    | 2.1/2" | 3"    | 3.1/2" |
| €         | 10,73  | 12,73 | 19,04  | 28,25 | 44,58  | 82,44 | 104,42 |

VA

NOTE: Les porte-filières pour cages en pouces sont en désuétude.

**PORTE-TARAUDS À CLIQUET**

Porte outils

Rose

Réf. TC

**TYPE**  
**T**

**SÉRIE COURTE**  
**QUALITÉ INDUSTRIELLE**

|      | CAPACITÉ<br>mm<br>min.-max. | Pour queues de tarauds |         | L1<br>mm | POIDS<br>g | QUALITÉ                  | TC    |
|------|-----------------------------|------------------------|---------|----------|------------|--------------------------|-------|
|      |                             | DIN                    | ISO     |          |            |                          | €     |
| TC3B | 2,6 - 5,5                   | M3 - 8                 | M3 - 6  | 85       | 180        | 1 <sup>ère</sup> Qualité | 27,28 |
| TC4B | 4,6 - 8,0                   | M5 - 12                | M6 - 12 | 110      | 300        | 1 <sup>ère</sup> Qualité | 36,86 |
| TC1B | 2,6 - 5,5                   | M3 - 8                 | M3 - 6  | 85       | 180        | 2 <sup>ème</sup> Qualité | 16,26 |
| TC2B | 4,6 - 8,0                   | M5 - 12                | M6 - 12 | 110      | 300        | 2 <sup>ème</sup> Qualité | 24,37 |

Réf. TL

**TYPE**  
**T**
**SÉRIE LONGUE**  
**QUALITÉ INDUSTRIELLE**

|     | CAPACITÉ<br>mm<br>min.-max. | Pour queues de tarauds |         | L1<br>mm | POIDS<br>g | QUALITÉ                  | TL    |
|-----|-----------------------------|------------------------|---------|----------|------------|--------------------------|-------|
|     |                             | DIN                    | ISO     |          |            |                          | €     |
| TL3 | 2,6 - 5,5                   | M3 - 8                 | M3 - 6  | 250      | 250        | 1 <sup>ère</sup> Qualité | 43,04 |
| TL4 | 4,6 - 8,0                   | M5 - 12                | M6 - 12 | 300      | 440        | 1 <sup>ère</sup> Qualité | 51,23 |
| TL1 | 2,6 - 5,5                   | M3 - 10                | M3 - 6  | 250      | 250        | 2 <sup>ème</sup> Qualité | 31,46 |
| TL2 | 4,6 - 8,0                   | M5 - 12                | M6 - 12 | 300      | 440        | 2 <sup>ème</sup> Qualité | 37,50 |

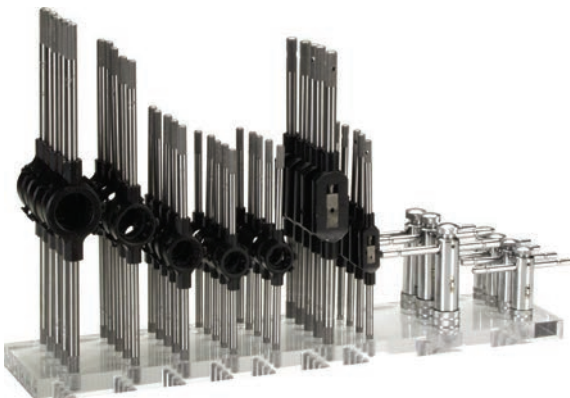
**PRÉSENTOIR EN MÉTHACRYLATE**

Dimensions: 500 x 320 x 110 mm

|       |               |           |   | GV-01                    |
|-------|---------------|-----------|---|--------------------------|
|       |               |           |   | €                        |
| GV-01 | N° 1 1/2<br>5 | N° 2<br>5 | 20x5 20x7 25x9<br>5 5 5<br>30x11 38x14<br>5 5 | TC1 TC2<br>4 4<br>735,54 |

**JEUX DE TARAUDS ET FILIÈRES HSS EN COFFRET MÉTALLIQUE**

**M3  
M12**

**HSS**



Réf. D624

**CONTENU**

|      |                                    |          |        |   | N° Pièces | 1ère Qualité<br>€ | 2ème Qualité*<br>€ |
|------|------------------------------------|----------|--------|---|-----------|-------------------|--------------------|
| D624 | M3 - M4 - M5 - M6 - M8 - M10 - M12 | N° 1.1/2 | 25 x 9 | - | 30        | 218,07            | 183,19             |

\* Tourne à gauche et porte-filières en zamak

**FILIÈRES HSS EN COFFRET MÉTALLIQUE**

**M3  
M12**

**HSS**



Réf. D671

**CONTENU**

|                   |                                    |                   |                   |        | N° Pièces | 1ère Qualité<br>€ | 2ème Qualité*<br>€ |
|-------------------|------------------------------------|-------------------|-------------------|--------|-----------|-------------------|--------------------|
| D671              | M3 - M4 - M5 - M6 - M8 - M10 - M12 | 20 x 5<br>30 x 11 | 20 x 7<br>38 x 14 | 25 x 9 | 12        | 217,42            | 178,64             |
| D671I<br>(Gauche) | M3 - M4 - M5 - M6 - M8 - M10 - M12 | 20 x 5<br>30 x 11 | 20 x 7<br>38 x 14 | 25 x 9 | 12        | 434,85            | 357,29             |

\* Porte-filières en zamak

**JEUX DE TARAUDS ET FILIÈRES HSS ET HSSCo EN COFFRET MÉTALLIQUE**
**M3  
M12**

**HSS**
**HSSCo  
5%**

Réf. D621



Réf. D655

**CONTENU**

|                   |                                     |  |              |   |     | N° Pièces | 1ère Qualité<br>€ | 2ème Qualité**<br>€ |
|-------------------|-------------------------------------|--|--------------|---|-----|-----------|-------------------|---------------------|
| D621              | M3 - M4 - M5 - M6<br>M8 - M10 - M12 | 2.5 / 3.3 / 4.2 / 5.0<br>6.8 / 8.5 / 10.2 mm | N° 1<br>N° 2 | 20 x 5 20 x 7 25 x 9<br>30 x 11 38 x 14 | TC1 | 43        | 463,02            | 390,39              |
| D652              | M3 - M4 - M5 - M6<br>M8 - M10 - M12 | 2.5 / 3.3 / 4.2 / 5.0<br>6.8 / 8.5 / 10.2 mm | N° 1<br>N° 2 | 20 x 5 20 x 7 25 x 9<br>30 x 11 38 x 14 | -   | 42        | 447,53            | 374,91              |
| D662              | M3-M4-M5-M6-M7<br>M8-M9-M10-M11-M12 | -  | N° 1<br>N° 2 | 20 x 5 20 x 7 25 x 9<br>30 x 11 38 x 14 | TC1 | 48        | 699,58            | 596,92              |
| D651              | M3 - M4 - M5 - M6<br>M8 - M10 - M12 | -  | N° 1<br>N° 2 | 20 x 5 20 x 7 25 x 9<br>30 x 11 38 x 14 | -   | 35        | 353,73            | 301,36              |
| D655*<br>(HSSCo)  | M3 - M4 - M5 - M6<br>M8 - M10 - M12 | 2.5 / 3.3 / 4.2 / 5.0<br>6.8 / 8.5 / 10.2 mm | N° 1<br>N° 2 | 20 x 5 20 x 7 25 x 9<br>30 x 11 38 x 14 | TC1 | 43        | 482,07            | 424,03              |
| D621I<br>(Gauche) | M3 - M4 - M5 - M6<br>M8 - M10 - M12 | 2.5 / 3.3 / 4.2 / 5.0<br>6.8 / 8.5 / 10.2 mm | N° 1<br>N° 2 | 20 x 5 20 x 7 25 x 9<br>30 x 11 38 x 14 | TC1 | 43        | 583,39            | 508,77              |

\*

**HSSCo  
5%**

\*\*Tourne à gauche et porte-filières en zamak

**JEUX DE TARAUDS ET FILIÈRES HSS ET HSSCo EN COFFRET MÉTALLIQUE AVEC GUIDES POUR FILIÈRES**

M3 M12 HSS HSSCo 5%

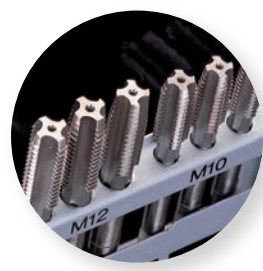

Réf. D656



GUIDES



Réf. D657



GUIDES

**CONTENU**

|                  |                                     |  |              |                               |          |     | N° Pièces | 1ère Qualité € | 2ème Qualité** € |
|------------------|-------------------------------------|--|--------------|-------------------------------|----------|-----|-----------|----------------|------------------|
| D656             | M3 - M4 - M5 - M6<br>M8 - M10 - M12 | 2.5 / 3.3 / 4.2 / 5.0<br>6.8 / 8.5 / 10.2 mm | N° 1<br>N° 2 | 20x5 20x7 25x9<br>30x11 38x14 | + GUIDES | TC1 | 43        | 493,90         | 424,14           |
| D657*<br>(HSSCo) | M3 - M4 - M5 - M6<br>M8 - M10 - M12 | 2.5 / 3.3 / 4.2 / 5.0<br>6.8 / 8.5 / 10.2 mm | N° 1<br>N° 2 | 20x5 20x7 25x9<br>30x11 38x14 |          | TC1 | 43        | 513,39         | 453,12           |

\* HSSCo 5%

\*\*Tourne à gauche et porte-filières en zamak

**JEUX DE TARAUDS ET FILIÈRES HSS ET HSSCo EN COFFRET MÉTALLIQUE**
**M3  
M20**
**M5  
M20**
**HSS**
**HSSCo  
5%**

Réf. D622



Réf. D623

**CONTENU**

|                      |   |              |   |  |            | N°<br>Pièces | 1ère<br>Qualité<br>€ | 2ème<br>Qualité**<br>€ |
|----------------------|---|--------------|---|--|------------|--------------|----------------------|------------------------|
| D622<br>(Automobile) | M3 - M4 - M5 - M6 - M8 - M10 - M12<br>M14 - M16 - M18 - M20 | N° 1<br>N° 3 | 20 x 5 20 x 7 25 x 9<br>30 x 11 38 x 14 45 x 18 |  | TC1<br>TC2 | 54           | 827,55               | 647,18                 |
| D658                 | M3 - M4 - M5 - M6 - M8 - M10 - M12<br>M14 - M16 - M18 - M20 | N° 1<br>N° 3 | 20 x 5 20 x 7 25 x 9<br>30 x 11 38 x 14 45 x 18 |  | -          | 52           | 798,64               | 637,79                 |
| D622I<br>(Gauche)    | M3 - M4 - M5 - M6 - M8 - M10 - M12<br>M14 - M16 - M18 - M20 | N° 1<br>N° 3 | 20 x 5 20 x 7 25 x 9<br>30 x 11 38 x 14 45 x 18 |  | TC1<br>TC2 | 54           | 1.301,81             | -                      |
| D659*<br>(HSSCo)     | M3 - M4 - M5 - M6 - M8 - M10 - M12<br>M14 - M16 - M18 - M20 | N° 1<br>N° 3 | 20 x 5 20 x 7 25 x 9<br>30 x 11 38 x 14 45 x 18 |  | -          | 52           | 1.570,26             | 1.339,89               |
| D623                 | M5 - M6 - M8 - M10 - M12<br>M14 - M16 - M18 - M20           | N° 1<br>N° 3 | 20 x 7 25 x 9<br>30 x 11 38 x 14 45 x 18        |  | TC1<br>TC2 | 45           | 792,57               | 630,63                 |
| D663                 | M5 - M6 - M7 - M8 - M9 - M10 - M12<br>M14 - M16 - M18 - M20 | N° 1<br>N° 3 | 20 x 7 25 x 9 30 x 11<br>38 x 14 45 x 18        |  | -          | 51           | 1.056,66             | 922,01                 |

\*

**HSSCo  
5%**

\*\* Tourne à gauche et porte-filières en zamak

**JEUX DE TARAUDS ET FILIÈRES HSS EN COFFRET MÉTALLIQUE ET BOIS**

**M1  
M10**

**M5  
M12**

**M3  
M24**

**M5  
M30**

**HSS**



Réf. D628



Réf. D626

**CONTENU**

|      |   |                      |   |  |     | N° Pièces | 1ère Qualité<br>€ | 2ème Qualité*<br>€ |
|------|---|----------------------|---|--|-----|-----------|-------------------|--------------------|
| D626 | M1 - M1.2 - M1.4 - M1.7 - M2.0 - M2.3<br>M2.6 - M3 - M3.5 - M4 - M5 - M6 - M8 - M10 | N° 0<br>N° 1         | 16 x 5 20 x 5 20 x 7<br>25 x 9 30 x 11                      |  | TC1 | 64        | -                 | 959,12             |
| D627 | M5 - M6 - M7 - M8 - M9 - M10 - M11 - M12  | N° 1<br>N° 2         | 20 x 7 25 x 9<br>30 x 11 38 x 14                            |  | TC1 | 39        | -                 | 716,50             |
| D625 | M3 - M4 - M5 - M6 - M8 - M10 - M12 - M14<br>M16 - M18 - M20 - M22 - M24             | N° 1<br>N° 4         | 20 x 5 20 x 7 25 x 9<br>30 x 11 38 x 14 45 x 18 55<br>x 22  |  | -   | 61        | 1.744,51          | 1.248,66           |
| D628 | M5 - M6 - M8 - M10 - M12 - M14 - M16<br>M18 - M20 - M22 - M24 - M27 - M30           | N° 1<br>N° 3<br>N° 5 | 20 x 7 25 x 9 30 x 11<br>38 x 14 45 x 18 55 x 22<br>65 x 25 |  | -   | 62        | -                 | 2.394,40           |

\* Tourne à gauche et porte-filières en zamak





**JEUX DE TARAUDS ET FILIÈRES HSS EN COFFRET MÉTALLIQUE**
**MF**
**HSS**

Réf. D634

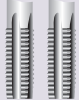

Réf. D636

**CONTENU**

|      |    |  |  |  |  | N°<br>Pièces | 1ère<br>Qualité<br>€ | 2ème<br>Qualité*<br>€ |
|------|---|---|---|---|---|--------------|----------------------|-----------------------|
| D634 | MF 3 x 0.35 - 4 x 0.5 - 5 x 0.5<br>MF 6 x 0.75 - 8 x 0.75 - 8 x 1.0<br>MF 10 x 1.0 - 12 x 1.5   |   | N° 1<br>N° 2  | 20 x 5 25 x 9<br>30 x 11 38 x 10  | TC1   | 31           | -                    | 688,70                |
| D635 | MF 6 x 0.75 - 8 x 0.75 - 8 x 1.0 - 10 x 1.0<br>MF 12 x 1.0 - 12 x 1.5 - 14 x 1.25 - 14 x 1.5<br>MF 16 x 1.5 - 18 x 1.5 - 20 x 1.5                           |   | N° 1<br>N° 3  | 20 x 7 25 x 9<br>30 x 11 38 x 10 45 x 14  | -   | 40           | 1.257,45             | 1.019,70              |
| D636 | MF 6 x 0.75 - 8 x 0.75 - 8 x 1.0 - 10 x 1.0<br>MF 12 x 1.0 - 12 x 1.5 - 14 x 1.25 - 14 x 1.5<br>MF 16 x 1.5 - 18 x 1.5 - 20 x 1.5 - 22 x 1.5<br>MF 24 x 1.5 |   | N° 1<br>N° 4  | 20 x 7 25 x 9 30 x 11<br>38 x 10 45 x 14 55 x 16                                    | -   | 47           | 1.724,99             | 1.360,05              |

\* Tourne à gauche et porte-filières en zamak



**JEUX DE TARAUDS ET FILIÈRES HSS EN COFFRET MÉTALLIQUE**



Réf. D638

**CONTENU**

|      |  |  |                      |  |   | N° Pièces | 1ère Qualité<br>€ | 2ème Qualité*<br>€ |
|------|--|--|----------------------|--|---|-----------|-------------------|--------------------|
| D637 | G 1/8 - 1/4 - 3/8 - 1/2 - 3/4 - 1"             |  | N° 1<br>N° 3<br>N° 5 | 30 x 11 38 x 10 45 x 14<br>55 x 16 65 x 18         | - | 26        | 1.396,16          | 1.007,57           |
| D638 | G 1/8 - 1/4 - 3/8 - 1/2 - 5/8 - 3/4 - 7/8 - 1" |  | N° 1<br>N° 3<br>N° 5 | 30 x 11 38 x 10 45 x 14<br>55 x 16 65 x 18         | - | 32        | 1.894,73          | 1.410,45           |
| D639 | G 1/4 - 3/8 - 1/2 - 3/4 - 1" - 1".1/4 - 1".1/2 |  | N° 2<br>N° 4<br>N° 7 | 38 x 10 45 x 14 55 x 16<br>65 x 18 75 x 20 90 x 22 | - | 30        | 3.495,46          | 2.634,23           |

\* Tourne à gauche et porte-filières en zamak



Réf. D640

**CONTENU**

|      |  |  |                      |   |     | N° Pièces | 1ère Qualité<br>€ | 2ème Qualité*<br>€ |
|------|--|--|----------------------|---|-----|-----------|-------------------|--------------------|
| D640 | BSW 1/8 - 3/16 - 1/4 - 5/16 - 3/8 - 7/16 - 1/2   |  | N° 1<br>N° 2         | 20 x 5 20 x 7 25 x 9<br>30 x 11 38 x 14                     | TC1 | 36        | 778,86            | 594,83             |
| D641 | BSW 1/4 - 5/16 - 3/8 - 7/16 - 1/2  |  | N° 1<br>N° 2         | 20 x 7 25 x 9<br>30 x 11 38 x 14                            | TC1 | 27        | 642,07            | 483,15             |
| D642 | BSW 1/4 - 5/16 - 3/8 - 7/16 - 1/2 - 5/8 - 3/4  |  | N° 1<br>N° 3         | 20 x 7 25 x 9 30 x 11<br>38 x 14 45 x 18                    | -   | 35        | 1.149,07          | 894,12             |
| D643 | BSW 1/4 - 5/16 - 3/8 - 7/16<br>1/2 - 5/8 - 3/4 - 7/8 - 1"                                      |  | N° 1<br>N° 4         | 20 x 7 25 x 9 30 x 11<br>38 x 14 45 x 18 55 x 22            | -   | 44        | 1.625,05          | 1.274,63           |
| D646 | BSW 1/4 - 5/16 - 3/8 - 7/16<br>1/2 - 5/8 - 3/4 - 7/8 - 1" - 1".1/8<br>1".1/4 - 1".3/8 - 1".1/2 |  | N° 1<br>N° 3<br>N° 5 | 20 x 7 25 x 9 30 x 11<br>38 x 14 45 x 18 55 x 22<br>65 x 25 | -   | 62        | -                 | 3.697,20           |

\* Tourne à gauche et porte-filières en zamak

**JEUX DE TARAUDS ET FILIÈRES HSS EN COFFRET MÉTALLIQUE**





BSF

HSS



Réf. D648

**CONTENU**

|      |  |  |  |  | N° Pièces | 1ère Qualité<br>€ | 2ème Qualité*<br>€ |
|------|---|---|---|---|-----------|-------------------|--------------------|
| D664 | BSF 1/4 - 5/16 - 3/8 - 7/16 - 1/2   | N° 1<br>N° 2  | 20 x 7 25 x 9<br>30 x 11 38 x 10  | TC1   | 22        | 631,20            | 538,59             |
| D648 | BSF 1/4 - 5/16 - 3/8 - 7/16 - 1/2 - 5/8 - 3/4                                     | N° 1<br>N° 3  | 20 x 7 25 x 9 30 x 11<br>38 x 10 45 x 14  | -   | 28        | 950,57            | 894,12             |
| D665 | BSF 1/4 - 5/16 - 3/8 - 7/16<br>1/2 - 5/8 - 3/4 - 7/8 - 1"                         | N° 1<br>N° 4  | 20 x 7 25 x 9 30 x 11<br>38 x 10 45 x 14 55 x 16                                  | -   | 35        | 1.662,64          | 1.418,69           |

\* Tourne à gauche et porte-filières en zamak





BSW  
BSF

HSS

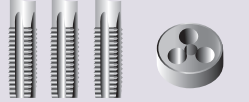

Réf. D666

**CONTENU**

|      |             |  |  |  | N° Pièces | 1ère Qualité<br>€ | 2ème Qualité*<br>€ |
|------|--|---|---|---|-----------|-------------------|--------------------|
| D666 | BSW 1/4 - 5/16 - 3/8 - 7/16 - 1/2 - 5/8 - 3/4<br>BSF 1/4 - 5/16 - 3/8 - 7/16 - 1/2 - 5/8 - 3/4 | N° 1<br>N° 3  | 20 x 7 25 x 9 30 x 11<br>38 x 14 45 x 18  | -   | 63        | 1.878,16          | 1.602,60           |





\* Tourne à gauche et porte-filières en zamak

**JEUX DE TARAUDS ET FILIÈRES HSS EN COFFRET MÉTALLIQUE**



Réf. D660

**CONTENU**



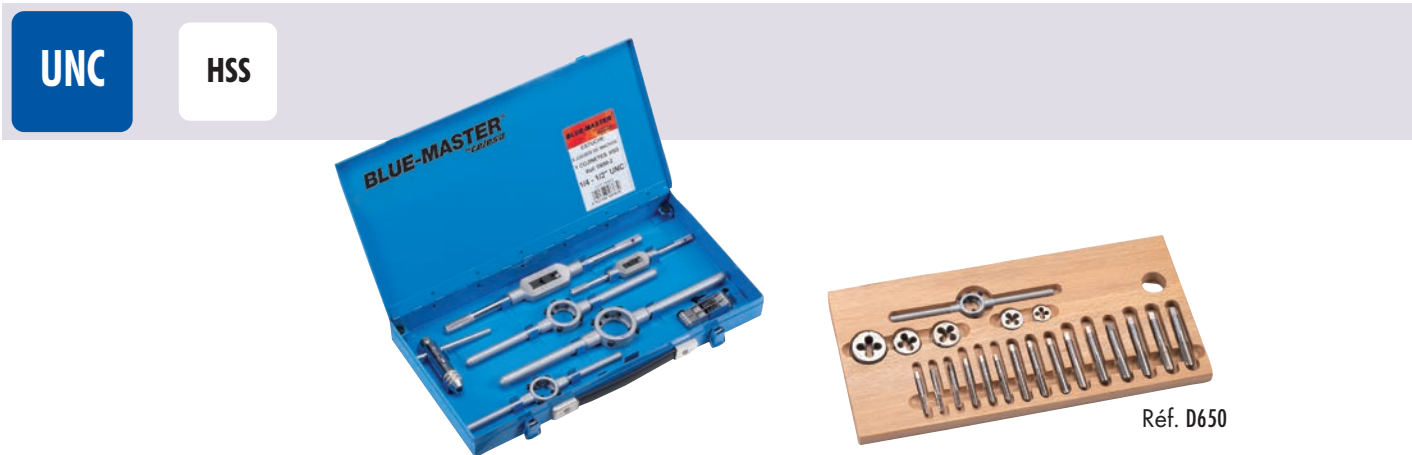

|      |  |  |  |  |  | N° Pièces | 1ère Qualité<br>€ | 2ème Qualité*<br>€ |
|------|---|---|---|---|---|-----------|-------------------|--------------------|
| D660 | NPT 1/8 - 1/4 - 3/8 - 1/2 - 3/4 - 1"  |   | N°1<br>N°3<br>N°5   | 30 x 11 38 x 14 45 x 18 55 x 22 65 x 25   | -   | 20        | 1.775,36          | 1.633,65           |
| D661 | NPT 1/8 - 1/4 - 3/8 - 1/2 - 3/4<br>1" - 1.1/4 - 1.1/2 - 2"                        |   | N°2<br>N°4<br>N°7   | 30 x 11 38 x 14 45 x 18 55 x 22 65 x 25 75 x 30 90 x 36 105 x 36                  | -   | 29        | 5.314,53          | 4.843,63           |

\* Tourne à gauche et porte-filières en zamak

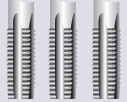

Réf. D650

**CONTENU**

|      |         |  |  |  |  | N° Pièces | 1ère Qualité<br>€ | 2ème Qualité*<br>€ |
|------|--|---|---|---|---|-----------|-------------------|--------------------|
| D650 | UNC 1/4 - 5/16 - 3/8 - 7/16 - 1/2  |   | N°1<br>N°2  | 20 x 7 25 x 9 30 x 11 38 x 14   | TC1   | 27        | 687,96            | 599,00             |
| D667 | UNC 1/4 - 5/16 - 3/8 - 7/16 - 1/2 - 5/8 - 3/4  |   | N°1<br>N°2  | 20 x 7 25 x 9 30 x 11 38 x 14 45 x 18   | -   | 35        | 1.108,43          | 945,80             |
| D654 | UNC 1/4 - 5/16 - 3/8 - 7/16<br>1/2 - 5/8 - 3/4 - 7/8 - 1"                                  |   | N°1<br>N°4  | 20 x 7 25 x 9 30 x 11 38 x 14 45 x 18 55 x 22                                       | -   | 44        | 1.788,56          | 1.623,78           |
| D668 | UNC 1/4 - 5/16 - 3/8 - 7/16 - 1/2 - 5/8 - 3/4<br>7/8 - 1" - 1.1/8 - 1.1/4 - 1.3/8 - 1.1/2" |   | N°1<br>N°3<br>N°6   | 20 x 7 25 x 9 30 x 11 38 x 14 45 x 18 55 x 22 65 x 25                               | -   | 62        | 4.187,38          | 3.573,03           |

\* Tourne à gauche et porte-filières en zamak

**JEUX DE TARAUDS ET FILIÈRES HSS EN COFFRET MÉTALLIQUE**





UNF

HSS

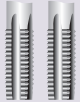

Réf. D644

**CONTENU**

|      |  |  |  |  |  | N°<br>Pièces | 1ère<br>Qualité<br>€ | 2ème<br>Qualité*<br>€ |          |
|------|---|---|---|---|---|--------------|----------------------|-----------------------|----------|
| D644 | UNF 1/4 - 5/16 - 3/8 - 7/16 - 1/2   |   | N° 1<br>N° 2  | 20 x 7 25 x 9<br>30 x 11 38 x 10  |   | TC1          | 22                   | 539,08                | 453,35   |
| D669 | UNF 1/4-5/16-3/8-7/16-1/2-5/8-3/4   |   | N° 1<br>N° 3  | 20 x 7 25 x 9 30 x 11<br>38 x 10 45 x 14  |   | -            | 28                   | 1.016,05              | 866,98   |
| D645 | UNF 1/4 - 5/16 - 3/8 - 7/16 - 1/2 - 5/8<br>3/4 - 7/8 - 1"                         |   | N° 1<br>N° 4  | 20 x 7 25 x 9 30 x 11<br>38 x 10 45 x 14 55 x 16                                  |   | -            | 34                   | 1.245,88              | 1.095,86 |

\* Tourne à gauche et porte-filières en zamak



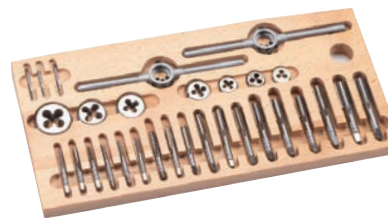

UNC  
UNF

HSS

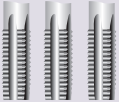

Réf. D670

**CONTENU**

|      |             |  |  |  |  | N°<br>Pièces | 1ère<br>Qualité<br>€ | 2ème<br>Qualité*<br>€ |          |
|------|--|---|---|---|---|--------------|----------------------|-----------------------|----------|
| D670 | UNC 1/4 - 5/16 - 3/8 - 7/16 - 1/2 - 5/8 - 3/4<br>UNF 1/4 - 5/16 - 3/8 - 7/16 - 1/2 - 5/8 - 3/4 |   | N° 1<br>N° 3  | 20 x 7 25 x 9 30 x 11<br>38 x 14 45 x 18  |   | -            | 35                   | 1.878,16              | 1.602,60 |

\* Tourne à gauche et porte-filières en zamak

**JEUX DE TARAUDS HSS ET HSS+TIN EN COFFRET MÉTALLIQUE**



Réf. JMB0









Réf. JMB2

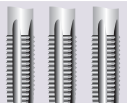

Réf. JMBT2

**CONTENU**

|                   |                                        |  |  |  | HSS<br>€ |        | TiN*<br>€ |
|-------------------|---|---|---|--|----------|--------|-----------|
| JMB2              | M3 - M4 - M5 - M6<br>M8 - M10 - M12   | -   | -   | -  | 158,83   | JMBT2  | 315,35    |
| JMB0              | M3 - M4 - M5 - M6<br>M8 - M10 - M12   | 2.5 / 3.3 / 4.2 / 5.0<br>6.8 / 8.5 / 10.2 mm                                      | -   | -  | 181,18   | JMBT0  | 353,89    |
| JMB1              | M3 - M4 - M5 - M6<br>M8 - M10 - M12   | 2.5 / 3.3 / 4.2 / 5.0<br>6.8 / 8.5 / 10.2 mm                                      | N° 1.1/2  | -  | 200,26   | JMBT1  | 371,48    |
| JMB5              | M3 - M4 - M5 - M6<br>M8 - M10 - M12   | 2.5 / 3.3 / 4.2 / 5.0<br>6.8 / 8.5 / 10.2 mm                                      | N° 1.1/2  | TC1  | 215,61   | JMBT5  | 389,25    |
| JMBI2<br>(Gauche) |  M3 - M4 - M5 - M6<br>M8 - M10 - M12   | -   | -   | -  | 294,53   | JMBIT2 | 547,83    |
| JMBI0<br>(Gauche) |  M3 - M4 - M5 - M6<br>M8 - M10 - M12  | 2.5 / 3.3 / 4.2 / 5.0<br>6.8 / 8.5 / 10.2 mm                                      | -   | -  | 341,19   | JMBIT0 | 594,18    |
| JMBI1<br>(Gauche) |  M3 - M4 - M5 - M6<br>M8 - M10 - M12 | 2.5 / 3.3 / 4.2 / 5.0<br>6.8 / 8.5 / 10.2 mm                                      | N° 1.1/2  | -  | 364,11   | JMBIT1 | 622,93    |

**TARAUDS FINISSEURS HSS ET HSS+TIN EN COFFRET MÉTALLIQUE**









Réf. JMB3



Réf. JMB4

**CONTENU**

| <b>3°</b>         |                                      |  |  |  | HSS<br>€ |        | TiN*<br>€ |
|-------------------|---|---|---|--|----------|--------|-----------|
| JMB3              | M3 - M4 - M5 - M6<br>M8 - M10 - M12   | -   | -   | -  | 77,46    | JMBT3  | 97,01     |
| JMB4              | M3 - M4 - M5 - M6<br>M8 - M10 - M12   | 2.5 / 3.3 / 4.2 / 5.0<br>6.8 / 8.5 / 10.2 mm  | -   | -  | 96,42    | JMBT4  | 128,16    |
| JMB7              | M3 - M4 - M5 - M6<br>M8 - M10 - M12   | 2.5 / 3.3 / 4.2 / 5.0<br>6.8 / 8.5 / 10.2 mm  | N° 1.1/2  | -  | 110,32   | JMBT7  | 177,76    |
| JMB6              | M3 - M4 - M5 - M6<br>M8 - M10 - M12   | 2.5 / 3.3 / 4.2 / 5.0<br>6.8 / 8.5 / 10.2 mm  | N° 1.1/2  | TC1  | 119,47   | JMBT6  | 189,48    |
| JMBI3<br>(Gauche) |  M3 - M4 - M5 - M6<br>M8 - M10 - M12 | -   | -   | -  | 104,29   | JMBIT3 | 194,01    |
| JMBI4<br>(Gauche) |  M3 - M4 - M5 - M6<br>M8 - M10 - M12 | 2.5 / 3.3 / 4.2 / 5.0<br>6.8 / 8.5 / 10.2 mm  | -   | -  | 139,77   | JMBIT4 | 257,17    |



**JEUX DE TARAUDS HSSCo EN COFFRET MÉTALLIQUE POUR INOX ET MATIÈRES DURES**
**HSSCo**  
**5%**

Réf. JMBX0

**CONTENU**

| INOX  |  MOX |  HSSCo |  |  | €      |
|-------|---|---|--|---|--------|
| JMBX0 | M3 - M4 - M5 - M6<br>M8 - M10 - M12   | 2.5 / 3.3 / 4.2 / 5.0<br>6.8 / 8.5 / 10.2 mm  | -  | -   | 281,65 |
| JMBX1 | M3 - M4 - M5 - M6<br>M8 - M10 - M12   | 2.5 / 3.3 / 4.2 / 5.0<br>6.8 / 8.5 / 10.2 mm  | N° 1.1/2   | -   | 296,42 |
| JMBX2 | M3 - M4 - M5 - M6<br>M8 - M10 - M12   | -   | -  | -   | 266,34 |

**CONTENU**

|  1100<br>N/mm <sup>2</sup> |  MOMD |  HSSCo |  |  | €      |
|---|--|---|--|---|--------|
| JMBMD0  | M3 - M4 - M5 - M6<br>M8 - M10 - M12  | 2.5 / 3.3 / 4.2 / 5.0<br>6.8 / 8.5 / 10.2 mm  | -  | -   | 294,13 |
| JMBMD1  | M3 - M4 - M5 - M6<br>M8 - M10 - M12  | 2.5 / 3.3 / 4.2 / 5.0<br>6.8 / 8.5 / 10.2 mm  | N° 1.1/2   | -   | 309,44 |
| JMBMD2  | M3 - M4 - M5 - M6<br>M8 - M10 - M12  | -   | -  | -   | 280,37 |

**FILIÈRES HSS EN COFFRET MÉTALLIQUE**

Réf. C5B3



**CONTENU**

|                   |  | HSS<br>€ |
|-------------------|--|----------|
| C5B3              | M3 - M4 - M5 - M6 - M8 - M10 - M12   | 141,84   |
| C5B31<br>(Gauche) | M3 - M4 - M5 - M6 - M8 - M10 - M12   | 283,67   |



**EXTRACTEUR DE TARAUDS CASSÉS POUR TARAUDS À GOUJURES DROITES**



**EXTRACTEUR À L'UNITÉ**

| MESURE DU TARAUD À EXTRAIRE |      | TARAUDS À MAIN  | TARAUDS MACHINE   | €/ Unité           |
|-----------------------------|------|---|---|--------------------|
| BSW UNC                     | M    |  |  | EXTRACTEUR COMPLET |
| --                          | M3   |   | W10043  | 44,81              |
| 1/8                         | M3,2 |   | W10053  | 44,81              |
| --                          | M3,5 |   | W10063  | 44,81              |
| 5/32                        | M4   |   | W10083  | 44,81              |
| 3/16                        | M5   |   | W10103  | 44,81              |
| --                          | M5,5 | W10124  | W10123  | 44,81              |
| 1/4                         | M6   | W10254  | W10253  | 46,11              |
| 5/16                        | M8   | W10314  | W10313  | 48,33              |
| --                          | M9   | W10374  | W10373  | 47,86              |
| 3/8                         | M10  | W10404  | W10373  | 47,86              |
| 7/16                        | M11  | W10434  | W10433  | 50,53              |
| 1/2                         | M12  | W10504  | W10503  | 54,04              |
| 9/16                        | M14  | W10564  | W10563  | 74,68              |
| 5/8                         | M16  | W10624  | W10623  | 81,27              |
| --                          | M18  | W10684  | W10753  | 100,70             |
| 3/4                         | M20  | W10754  | W10753  | 100,70             |
| 7/8                         | M22  | W10874  | W10873  | 110,18             |
| 1"                          | M25  | W11004  | W11003  | 122,88             |

**LAMES DE RECHANGE**

| TARAUDS À MAIN  | TARAUDS MACHINE   | €/ Unité   |
|---|---|------------|
|  |  | LAME EXTRA |
|   | W12043  | 2,39       |
|   | W12053  | 2,39       |
|   | W12063  | 2,39       |
|   | W12083  | 2,39       |
|   | W12103  | 3,56       |
|   | W12123  | 3,56       |
|   | W12253  | 4,34       |
| W12314  | W12313  | 4,89       |
| W12374  |   | 4,89       |
| W12404  | W12373  | 5,05       |
| W12434  | W12433  | 5,13       |
| W12504  | W12503  | 6,46       |
| W12564  | W12563  | 7,20       |
| W12624  | W12623  | 9,20       |
| W12684  |   | 9,20       |
| W12754  | W12753  | 9,74       |
| W12874  | W12873  | 12,62      |
| W13004  | W13003  | 21,02      |

**3 ÉTAPES POUR L'EXTRACTION DE TARAUDS CASSÉS À GOUJURES DROITES**

Retirer tous les copeaux du taraud cassé. Introduire les lames de l'extracteur dans les goujures avec fermeté jusqu'au fond.



Pousser le support vers le bas jusqu'à toucher le taraud cassé. Glisser le cylindre vers le bas jusqu'à toucher le matériel travaillé.



Appliquer un tourne à gauche au carré de l'extracteur. Tourner à gauche un certain nombre de fois jusqu'à son déblocage et faire sortir le taraud cassé.

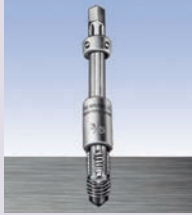





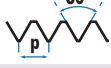
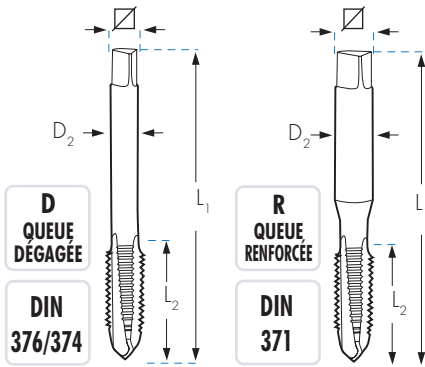

**JEUX D'EXTRACTEURS DE TARAUDS CASSÉS (GOUJURES DROITES)**



| N° (DE) GOUJURES | MESURES INCLUSES POUR TARAUDS MACHINE ET TARAUDS À MAIN: 3 et 4 GOUJURES |                                      |
|------------------|--|--------------------------------------|
| W180013          | 3  | M5- M6- M8- M10- M11- M12            |
| W180014          | 4  | 3/16 - 1/4 - 5/16 - 3/8 - 7/16 - 1/2 |
| W180023          | 3  | M6- M8 - M10- M11- M12- M16          |
| W180024          | 4  | 1/4 - 5/16 - 3/8 - 7/16 - 1/2 - 5/8  |
| W180153          | 3  | M3- M3,2- M3,5- M4-M5- M5,50- M6- M8 |
| W180154          | 4  | M9- M10- M12- M16- M18- M22- M25     |

**TARAUDS MACHINE HSSCo**
**M**  
**MF**
**DIN 13**

**HSSCo**  
**5%**
**TOL**  
**6H**
**Vc**  
**12 m/min**

|  |  | L <sub>1</sub> x L <sub>2</sub> x D <sub>2</sub> x <br>mm | M1D                | M2D             | M3D  | M4D   | M1R                | M2R             | M3R  | M4R  |
|---|---|--|--------------------|-----------------|--|---|--------------------|-----------------|--|--|
|   |   |  | ENTRÉE DROITE<br>€ | ENTRÉE GUN<br>€ |  15°<br>€ |  35°<br>€ | ENTRÉE DROITE<br>€ | ENTRÉE GUN<br>€ |  15°<br>€ |  35°<br>€ |
| M 1x0,25  | 0,75  | R 40 x 5,5 x 2,5 x 2,1   |                    |                 |  |   | 39,75              |                 |  |  |
| M 1,1x0,25  | 0,85  | R 40 x 6 x 2,5 x 2,1   |                    |                 |  |   | 38,67              |                 |  |  |
| M 1,2x0,25  | 0,95  | R 40 x 6 x 2,5 x 2,1   |                    |                 |  |   | 36,69              |                 |  |  |
| M 1,4x0,30  | 1,10  | R 40 x 7 x 2,5 x 2,1   |                    |                 |  |   | 36,69              |                 |  |  |
| M 1,6x0,35  | 1,25  | R 40 x 8 x 2,5 x 2,1   |                    |                 |  |   | 36,04              |                 |  |  |
| M 1,7x0,35  | 1,35  | R 40 x 8 x 2,5 x 2,1   |                    |                 |  |   | 34,69              |                 |  |  |
| M 1,8x0,35  | 1,45  | R 40 x 8 x 2,5 x 2,1   |                    |                 |  |   | 33,84              |                 |  |  |
| M 2x0,40  | 1,60  | R 40 x 8 x 2,8 x 2,1   |                    |                 |  |   | 16,45              | 17,54           | 20,18  | 19,09  |
| M 2,2x0,45  | 1,75  | R 40 x 9 x 2,8 x 2,1   |                    |                 |  |   | 17,60              |                 |  |  |
| M 2,3x0,40  | 1,90  | R 40 x 9 x 2,8 x 2,1   |                    |                 |  |   | 16,22              |                 |  |  |
| M 2,5x0,45  | 2,05  | R 50 x 9 x 2,8 x 2,1   |                    |                 |  |   | 16,45              | 17,54           | 20,18  | 19,09  |
| M 2,6x0,45  | 2,10  | R 50 x 9 x 2,8 x 2,1   |                    |                 |  |   | 15,73              | 17,86           |  | 34,20  |
| M 3x0,50  | 2,50  | R 56 x 11 x 3,5 x 2,7<br>D 56 x 11 x 2,2 x 1,8   | 9,53               | 10,38           | 14,95  | 12,51   | 10,79*             | 10,86           | 14,79  | 14,03  |
| M 3x0,60  | 2,40  | R 56 x 11 x 3,5 x 2,7  |                    |                 |  |   | 19,18              | 20,94           |  | 26,62  |
| M 3,5x0,60  | 2,90  | R 56 x 12 x 4,0 x 3,0<br>D 56 x 12 x 2,5 x 2,1   |                    |                 |  |   | 15,83              | 16,47           | 20,49  | 19,98  |
| M 3,5x0,75  | 2,75  | R 56 x 12 x 4,0 x 3,0  |                    |                 |  |   | 19,97              |                 |  |  |
| M 4x0,50  | 3,50  | R 63 x 13 x 4,5 x 3,4<br>D 63 x 13 x 2,8 x 2,1   | 20,68              | 23,18           |  | 24,76   | 22,58              | 24,19           |  | 28,01  |
| M 4x0,70  | 3,30  | R 63 x 13 x 4,5 x 3,4<br>D 63 x 13 x 2,8 x 2,1   | 9,70               | 10,54           | 14,56  | 12,39   | 12,15*             | 11,59           | 14,95  | 14,04  |
| M 4x0,75  | 3,25  | R 63 x 13 x 4,5 x 3,4  |                    |                 |  |   | 16,54              | 18,35           |  |  |
| M 4x0,80  | 3,20  | R 63 x 13 x 4,5 x 3,4  |                    |                 |  |   | 87,80              |                 |  |  |
| M 4,5x0,50  | 4,00  | R 70 x 14 x 6,0 x 4,9  |                    |                 |  |   |                    | 28,16           |  |  |
| M 4,5x0,75  | 3,75  | R 70 x 14 x 6,0 x 4,9  |                    |                 |  |   | 21,39              | 23,55           |  |  |
| M 5x0,50  | 4,50  | R 70 x 14 x 6,0 x 4,9<br>D 70 x 11 x 3,5 x 2,7   | 21,30              | 23,85           |  | 25,05   | 23,26              | 24,87           |  | 29,90  |
| M 5x0,75  | 4,50  | R 74 x 14 x 6,0 x 4,9<br>D 70 x 16 x 3,5 x 2,7   |                    |                 |  |   | 20,85              | 23,57           |  | 29,69  |
| M 5x0,80  | 4,20  | R 70 x 16 x 6,0 x 4,9<br>D 70 x 16 x 3,5 x 2,7   | 9,70               | 10,64           | 13,97  | 11,90   | 11,00*             | 11,66           | 15,09  | 13,47  |
| M 5x0,90  | 4,10  | R 70 x 15 x 6,0 x 4,9<br>D 70 x 16 x 3,5 x 2,7   |                    |                 |  |   | 17,47              | 22,51           |  |  |
| M 5x1,00  | 4,00  | R 72 x 17 x 6,0 x 4,9  |                    |                 |  |   | 46,82              |                 |  |  |
| M 5,5x0,90  | 4,60  | R 80 x 17 x 6,0 x 4,9  |                    |                 |  |   | 46,82              |                 |  |  |
| M 6x0,50  | 5,50  | R 80 x 17 x 6,0 x 4,9<br>D 80 x 13 x 4,5 x 3,4   | 23,82              | 23,98           |  | 26,19   | 29,33              |                 |  |  |
| M 6x0,75  | 5,25  | R 80 x 13 x 6,0 x 4,9<br>D 80 x 13 x 4,5 x 3,4   | 16,60              | 19,78           |  | 22,25   | 18,99              | 22,14           |  | 26,58  |
| M 6x1,00  | 5,00  | R 80 x 19 x 6,0 x 4,9<br>D 80 x 19 x 4,5 x 3,4   | 11,07              | 11,66           | 15,88  | 13,05   | 12,14*             | 12,34           | 16,07  | 14,77  |

\*Consultez le prix des tarauds à gauche disponibles à la page 217



TARAUDS MACHINE HSSCo



















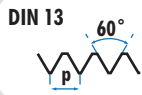
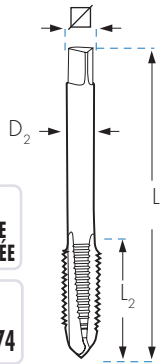

|                  |              |   | L1 x L2 x D2 x  mm | M1D           | M2D        | M3D   | M4D   | M1R           | M2R        | M3R   | M4R   |
|------------------|--------------|---|---|---------------|------------|---|---|---------------|------------|---|---|
|                  |              |   |   | ENTRÉE DROITE | ENTRÉE GUN |  15° |  35° | ENTRÉE DROITE | ENTRÉE GUN |  15° |  35° |
| M 6x1,25         | 4,75         | R | 80 x 17 x 6,0 x 4,9   |               |            |   |   | 46,00         |            |   |   |
| M 7x0,75         | 6,25         | D | 80 x 13 x 5,5 x 4,3   | 21,19         | 23,87      |   | 26,19   |               |            |   |   |
| <b>M 7x1,00</b>  | <b>6,00</b>  | R | 80 x 19 x 7,0 x 5,5   | 15,30         | 17,69      | 18,93   | 18,23   | 16,38 *       | 17,78      | 21,60   | 21,38   |
|                  |              | D | 80 x 19 x 5,5 x 4,3   |               |            |   |   |               |            |   |   |
| M 8x0,50         | 7,50         | D | 80 x 13 x 6 x 4,9   | 29,86         |            |   |   |               |            |   |   |
| M 8x0,75         | 7,25         | D | 80 x 13 x 6 x 4,9   | 20,84         | 24,97      |   | 26,19   |               |            |   |   |
| M 8x1,00         | 7,00         | D | 90 x 20 x 6 x 4,9   | 17,69         | 20,32      | 23,23   | 21,66   |               |            |   |   |
| <b>M 8x1,25</b>  | <b>6,80</b>  | R | 90 x 22 x 8 x 6,2   | 12,41         | 13,21      | 17,91   | 15,37   | 14,13 *       | 14,14      | 18,63   | 17,28   |
|                  |              | D | 90 x 22 x 6 x 4,9   |               |            |   |   |               |            |   |   |
| M 8x1,50         | 6,50         | D | 90 x 20 x 6 x 4,9   | 83,52         |            |   |   |               |            |   |   |
| M 9x1,00         | 8,00         | D | 90 x 20 x 7 x 5,5   | 24,34         | 24,61      |   | 26,93   |               |            |   |   |
| <b>M 9x1,25</b>  | <b>7,80</b>  | R | 90 x 22 x 9 x 7,0   | 20,51         | 22,40      | 26,12   | 26,50   | 22,58         | 23,74      | 29,24   | 29,17   |
|                  |              | D | 90 x 22 x 7 x 5,5   |               |            |   |   |               |            |   |   |
| M 10x0,50        | 9,50         | D | 90 x 20 x 7 x 5,5   | 82,74         |            |   |   |               |            |   |   |
| M 10x0,75        | 9,25         | D | 90 x 16 x 7 x 5,5   | 28,30         | 28,97      |   | 31,66   |               |            |   |   |
| M 10x1,00        | 9,00         | D | 90 x 16 x 7 x 5,5   | 19,59         | 22,57      | 27,42   | 27,37   |               |            |   |   |
| M 10x1,25        | 8,80         | D | 100 x 22 x 7 x 5,5  | 22,43         | 26,98      | 29,87   | 29,82   |               |            |   |   |
| <b>M 10x1,50</b> | <b>8,50</b>  | R | 100 x 24 x 10 x 8,0   | 14,29         | 15,99      | 21,30   | 18,40   | 15,72 *       | 17,42      | 22,58   | 20,45   |
|                  |              | D | 100 x 24 x 7 x 5,5  |               |            |   |   |               |            |   |   |
| M 11x1,00        | 10,00        | D | 90 x 20 x 8 x 6,2   | 32,58         | 34,61      | 87,49   | 41,47   |               |            |   |   |
| M 11x1,25        | 9,75         | D | 100 x 22 x 8 x 6,2  | 33,29         | 36,99      | 87,49   | 41,03   |               |            |   |   |
| <b>M 11x1,50</b> | <b>9,50</b>  | D | 100 x 24 x 8 x 6,2  | 26,00         | 29,90      | 63,79   | 59,12   |               |            |   |   |
| M 12x0,75        | 11,25        | D | 100 x 22 x 9 x 7,0  | 50,98         |            |   |   |               |            |   |   |
| M 12x1,00        | 11,00        | D | 100 x 22 x 9 x 7,0  | 26,64         | 29,65      | 33,82   | 33,76   |               |            |   |   |
| M 12x1,25        | 10,75        | D | 100 x 22 x 9 x 7,0  | 26,98         | 29,94      | 32,37   | 32,32   |               |            |   |   |
| M 12x1,50        | 10,50        | D | 100 x 22 x 9 x 7,0  | 24,11 *       | 26,73      | 31,14   | 31,09   |               |            |   |   |
| <b>M 12x1,75</b> | <b>10,20</b> | D | 110 x 28 x 9 x 7,0  | 17,21 *       | 19,95      | 27,25   | 23,49   |               |            |   |   |
| M 13x0,75        | 12,25        | D | 100 x 22 x 11 x 9,0   | 88,98         |            |   |   |               |            |   |   |
| M 13x1,00        | 12,00        | D | 100 x 22 x 11 x 9,0   | 47,11         | 48,03      |   |   |               |            |   |   |
| M 13x1,25        | 11,75        | D | 100 x 22 x 11 x 9,0   | 47,11         | 53,36      |   |   |               |            |   |   |
| M 13x1,50        | 11,50        | D | 100 x 22 x 11 x 9,0   | 47,11         | 48,03      |   |   |               |            |   |   |
| <b>M 13x1,75</b> | <b>11,25</b> | D | 100 x 28 x 11 x 9,0   | 45,06         | 53,36      |   |   |               |            |   |   |
| M 14x0,75        | 13,25        | D | 100 x 22 x 11 x 9,0   | 88,98         |            |   |   |               |            |   |   |
| M 14x1,00        | 13,00        | D | 100 x 22 x 11 x 9,0   | 41,30         | 45,44      | 52,15   | 50,57   |               |            |   |   |
| M 14x1,25        | 12,80        | D | 100 x 22 x 11 x 9,0   | 36,49         | 39,85      | 47,83   | 47,75   |               |            |   |   |
| M 14x1,50        | 12,50        | D | 100 x 22 x 11 x 9,0   | 28,72 *       | 31,63      | 37,72   | 37,64   |               |            |   |   |
| <b>M 14x2,00</b> | <b>12,00</b> | D | 110 x 30 x 11 x 9,0   | 28,51 *       | 30,64      | 36,72   | 35,36   |               |            |   |   |
| M 15x1,00        | 14,00        | D | 100 x 22 x 12 x 9,0   | 54,53         | 56,64      |   | 58,48   |               |            |   |   |
| M 15x1,25        | 13,75        | D | 100 x 22 x 12 x 9,0   | 57,90         | 62,69      |   |   |               |            |   |   |
| M 15x1,50        | 13,50        | D | 100 x 22 x 12 x 9,0   | 46,26         | 53,26      | 129,81  | 58,33   |               |            |   |   |
| <b>M 15x2,00</b> | <b>13,00</b> | D | 110 x 30 x 12 x 9,0   | 56,64         | 62,33      |   |   |               |            |   |   |
| M 16x1,00        | 15,00        | D | 100 x 22 x 12 x 9,0   | 51,39         | 53,45      | 73,01   | 58,29   |               |            |   |   |
| M 16x1,25        | 14,75        | D | 100 x 22 x 12 x 9,0   | 51,48         | 53,93      | 81,19   | 58,52   |               |            |   |   |
| M 16x1,50        | 14,50        | D | 100 x 22 x 12 x 9,0   | 33,96 *       | 39,56      | 47,00   | 46,92   |               |            |   |   |
| <b>M 16x2,00</b> | <b>14,00</b> | D | 110 x 32 x 12 x 9,0   | 33,56 *       | 34,18      | 44,37   | 40,82   |               |            |   |   |
| M 17x1,00        | 16,00        | D | 100 x 22 x 12 x 9,0   | 101,36        |            |   |   |               |            |   |   |
| M 17x1,25        | 15,75        | D | 100 x 22 x 12 x 9,0   | 101,36        |            |   |   |               |            |   |   |
| M 17x1,50        | 15,50        | D | 100 x 22 x 12 x 9,0   | 101,36        |            |   |   |               |            |   |   |
| M 18x1,00        | 17,00        | D | 110 x 25 x 14 x 11,0  | 57,55         | 63,26      |   | 71,32   |               |            |   |   |
| M 18x1,25        | 16,75        | D | 110 x 25 x 14 x 11,0  | 70,71         |            |   |   |               |            |   |   |
| M 18x1,50        | 16,50        | D | 110 x 25 x 14 x 11,0  | 44,94 *       | 49,45      | 57,75   | 56,71   |               |            |   |   |
| M 18x2,00        | 16,00        | D | 125 x 30 x 14 x 11,0  | 58,86         | 67,69      | 114,30  | 71,80   |               |            |   |   |

\*Consultez le prix des tarauds à gauche disponibles à la page 217

**TARAUDS MACHINE HSSCo**
**M**  
**MF**

**HSSCo**  
**5%**
**TOL**  
**6H**
**D**  
**QUEUE**  
**DÉGAGÉE**
**DIN**  
**376/374**
**Vc**  
**12**  
m/min

**D**  
**QUEUE**  
**DÉGAGÉE**
**DIN**  
**376/374**

|  |  |  | L <sub>1</sub> x L <sub>2</sub> x D <sub>2</sub> x <br><small>mm</small> | M1D                   | M2D                | M3D   | M4D   |
|---|---|--|---|-----------------------|--------------------|---|---|
|   |   |  |   | ENTRÉE<br>DROITE<br>€ | ENTRÉE<br>GUN<br>€ |  15°<br>€ |  35°<br>€ |
| M 18x2,50   | 15,50   | D  | 125 x 34 x 14 x 11,0  | 48,29*                | 48,70              | 59,73   | 57,52   |
| M 19x1,00   | 18,00   | D  | 110 x 22 x 14 x 11,0  | 133,17                |                    |   |   |
| M 19x1,25   | 17,75   | D  | 110 x 25 x 14 x 11,0  | 131,88                |                    |   |   |
| M 19x1,50   | 17,50   | D  | 110 x 25 x 14 x 11,0  | 130,70                |                    |   |   |
| M 20x1,00   | 19,00   | D  | 125 x 25 x 16 x 12,0  | 66,72                 | 75,95              |   | 80,30   |
| M 20x1,25   | 18,75   | D  | 125 x 25 x 16 x 12,0  | 63,99                 |                    |   |   |
| M 20x1,50   | 18,50   | D  | 125 x 25 x 16 x 12,0  | 50,91*                | 55,94              | 64,91   | 64,79   |
| M 20x2,00   | 18,00   | D  | 140 x 32 x 16 x 12,0  | 66,72                 | 73,35              |   | 80,81   |
| M 20x2,50   | 17,50   | D  | 140 x 34 x 16 x 12,0  | 51,39*                | 57,01              | 63,74   | 61,40   |
| M 21x1,00   | 20,00   | D  | 125 x 25 x 16 x 12,0  | 193,34                |                    |   |   |
| M 21x1,25   | 19,75   | D  | 125 x 25 x 16 x 12,0  | 193,34                |                    |   |   |
| M 21x1,50   | 19,50   | D  | 125 x 25 x 16 x 12,0  | 184,65                |                    |   |   |
| M 22x1,00   | 21,00   | D  | 125 x 25 x 18 x 14,5  | 83,32                 | 89,61              |   | 96,84   |
| M 22x1,25   | 20,75   | D  | 125 x 25 x 18 x 14,5  | 133,17                |                    |   |   |
| M 22x1,50   | 20,50   | D  | 125 x 25 x 18 x 14,5  | 61,27                 | 67,39              | 71,20   | 67,62   |
| M 22x2,00   | 20,00   | D  | 140 x 32 x 18 x 14,5  | 83,32                 | 93,72              |   | 96,84   |
| M 22x2,50   | 19,50   | D  | 140 x 34 x 18 x 14,5  | 62,21*                | 68,42              | 74,93   | 74,83   |
| M 23x1,00   | 22,00   | D  | 125 x 25 x 18 x 14,5  | 187,98                |                    |   |   |
| M 23x1,50   | 21,50   | D  | 125 x 25 x 18 x 14,5  | 187,98                |                    |   |   |
| M 24x1,00   | 23,00   | D  | 140 x 25 x 18 x 14,5  | 92,84                 | 102,92             |   | 117,73  |
| M 24x1,25   | 22,75   | D  | 140 x 25 x 18 x 14,5  | 193,34                |                    |   |   |
| M 24x1,50   | 22,50   | D  | 140 x 28 x 18 x 14,5  | 75,35                 | 82,84              | 95,17   | 95,00   |
| M 24x2,00   | 22,00   | D  | 140 x 28 x 18 x 14,5  | 96,14*                | 104,74             |   | 107,87  |
| M 24x3,00   | 21,00   | D  | 160 x 38 x 18 x 14,5  | 74,47*                | 80,59              | 90,30   | 90,95   |
| M 25x1,00   | 24,00   | D  | 140 x 28 x 18 x 14,5  | 165,49                |                    |   |   |
| M 25x1,25   | 23,75   | D  | 140 x 28 x 18 x 14,5  | 261,51                |                    |   |   |
| M 25x1,50   | 23,50   | D  | 140 x 28 x 18 x 14,5  | 110,73                | 109,31             |   |   |
| M 25x2,00   | 23,00   | D  | 140 x 28 x 18 x 14,5  | 250,11                | 275,13             |   |   |
| M 26x1,00   | 25,00   | D  | 140 x 28 x 18 x 14,5  | 128,48                |                    |   |   |
| M 26x1,50   | 24,50   | D  | 140 x 28 x 18 x 14,5  | 98,23                 | 106,51             | 178,30  | 117,59  |
| M 26x2,00   | 24,00   | D  | 140 x 28 x 18 x 14,5  | 108,38                | 110,05             |   | 114,16  |
| M 27x1,00   | 26,00   | D  | 140 x 28 x 20 x 16,0  | 124,01                | 128,49             |   |   |
| M 27x1,50   | 25,50   | D  | 140 x 28 x 20 x 16,0  | 110,95                | 116,47             | 259,14  | 142,89  |
| M 27x2,00   | 25,00   | D  | 140 x 28 x 20 x 16,0  | 121,88*               | 137,15             |   |   |

\*Consultez le prix des tarauds à gauche disponibles à la page 217

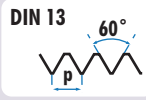
**TARAUDS MACHINE HSSCo**

**M  
MF**







**HSSCo  
5%**

**TOL  
6H**

**D  
QUEUE  
DÉGAGÉE**

**DIN  
376/374**







|  |  | L <sub>1</sub> x L <sub>2</sub> x D <sub>2</sub> x  | M1D                | M2D             | M3D  | M4D  |
|---|---|--|--------------------|-----------------|--|--|
|   |   |  | ENTRÉE DROITE<br>€ | ENTRÉE GUN<br>€ |  15°<br>€ |  35°<br>€ |
| <b>M 27x3,00</b>  | <b>24,00</b>  | D 160 x 36 x 20 x 16   | 92,96*             | 101,93          | 111,11   | 111,91   |
| M 28x1,00   | 27,00   | D 140 x 28 x 20 x 16   | 250,11             |                 |  |  |
| M 28x1,50   | 26,50   | D 140 x 28 x 20 x 16   | 110,95             | 121,81          | 134,94   | 126,52   |
| M 28x2,00   | 26,00   | D 140 x 28 x 20 x 16   | 124,48             | 131,21          | 159,04   | 142,55   |
| M 30x1,00   | 29,00   | D 150 x 28 x 22 x 18   | 141,93             | 146,35          |  | 160,11   |
| M 30x1,50   | 28,50   | D 150 x 28 x 22 x 18   | 115,65             | 127,27          | 146,34   | 146,06   |
| M 30x2,00   | 28,00   | D 150 x 28 x 22 x 18   | 139,98*            | 147,20          |  | 160,49   |
| <b>M 30x3,50</b>  | <b>26,50</b>  | D 180 x 40 x 22 x 18   | 119,13*            | 130,99          | 142,41   | 143,41   |
| M 32x1,00   | 31,00   | D 150 x 28 x 22 x 18   | 321,15             | 341,00          |  |  |
| M 32x1,50   | 30,50   | D 150 x 28 x 22 x 18   | 146,35             | 160,67          | 180,30   |  |
| M 32x2,00   | 30,00   | D 150 x 28 x 22 x 18   | 165,35             | 182,86          |  |  |
| M 33x1,00   | 32,00   | D 160 x 30 x 25 x 20   | 307,13             |                 |  |  |
| M 33x1,50   | 31,50   | D 160 x 30 x 25 x 20   | 158,77             | 174,87          |  | 194,22   |
| M 33x2,00   | 31,00   | D 160 x 30 x 25 x 20   | 189,16             | 176,38          |  | 200,12   |
| <b>M 33x3,50</b>  | <b>29,50</b>  | D 180 x 40 x 25 x 20   | 143,15*            | 164,72          |  | 181,04   |
| M 34x1,50   | 32,50   | D 170 x 30 x 28 x 22   | 175,22             | 182,04          |  |  |
| M 34x2,00   | 32,00   | D 160 x 30 x 28 x 22   | 382,67             |                 |  |  |
| M 35x1,50   | 33,50   | D 170 x 30 x 28 x 22   | 189,35             | 191,71          |  | 202,51   |
| M 35x2,00   | 33,00   | D 170 x 30 x 28 x 22   | 340,04             | 374,33          |  |  |
| M 36x1,50   | 34,50   | D 170 x 30 x 28 x 22   | 175,22             | 209,04          |  | 241,46   |
| M 36x2,00   | 34,00   | D 170 x 30 x 28 x 22   | 223,52             | 215,94          |  |  |
| M 36x3,00   | 33,00   | D 200 x 50 x 28 x 22   | 226,26             | 216,35          |  | 252,39   |
| <b>M 36x4,00</b>  | <b>32,00</b>  | D 200 x 50 x 28 x 22   | 180,93*            | 201,29          | 231,68   | 221,66   |
| M 38x1,50   | 36,50   | D 170 x 30 x 28 x 22   | 186,79             | 210,47          |  |  |
| M 38x2,00   | 36,00   | D 170 x 32 x 28 x 22   | 397,04             | 436,75          |  |  |
| M 39x1,50   | 37,50   | D 170 x 32 x 32 x 24   | 293,50             |                 |  |  |
| M 39x2,00   | 37,00   | D 170 x 32 x 32 x 24   | 293,50             |                 |  |  |
| M 39x3,00   | 36,00   | D 200 x 47 x 32 x 24   | 383,32             |                 |  |  |
| <b>M 39x4,00</b>  | <b>35,00</b>  | D 200 x 50 x 32 x 24   | 223,36             | 232,18          |  | 247,46   |
| M 40x1,50   | 38,50   | D 170 x 30 x 32 x 24   | 244,25             | 262,85          |  |  |
| M 40x2,00   | 38,00   | D 170 x 30 x 32 x 24   | 294,30             |                 |  |  |
| M 40x3,00   | 37,00   | D 200 x 47 x 32 x 24   | 256,49             | 263,92          |  |  |
| M 42x1,50   | 40,50   | D 170 x 30 x 32 x 24   | 268,95             | 260,45          |  |  |
| M 42x2,00   | 40,00   | D 170 x 30 x 32 x 24   | 336,68             |                 |  |  |
| M 42x3,00   | 39,00   | D 200 x 45 x 32 x 24   | 291,78             | 280,40          |  |  |
| <b>M 42x4,50</b>  | <b>37,50</b>  | D 200 x 56 x 32 x 24   | 287,23             | 298,48          |  | 331,54   |
| M 45x1,50   | 43,50   | D 180 x 32 x 36 x 29   | 321,21             | 353,31          |  |  |
| M 45x2,00   | 43,00   | D 180 x 32 x 36 x 29   | 389,83             |                 |  |  |
| M 45x3,00   | 42,00   | D 200 x 47 x 36 x 29   | 389,83             |                 |  |  |
| <b>M 45x4,50</b>  | <b>40,50</b>  | D 220 x 58 x 36 x 29   | 313,76             | 345,10          |  |  |
| M 48x1,50   | 46,50   | D 190 x 32 x 36 x 29   | 313,76             |                 |  |  |
| M 48x2,00   | 46,00   | D 190 x 32 x 36 x 29   | 492,67             |                 |  |  |
| M 48x3,00   | 45,00   | D 220 x 52 x 36 x 29   | 472,42             |                 |  |  |
| <b>M 48x5,00</b>  | <b>43,00</b>  | D 250 x 65 x 36 x 29   | 385,83             | 424,38          |  |  |
| M 50x1,50   | 48,50   | D 190 x 32 x 36 x 29   | 383,76             |                 |  |  |
| M 52x1,50   | 50,50   | D 190 x 32 x 40 x 32   | 371,48             |                 |  |  |
| M 52x2,00   | 50,00   | D 190 x 32 x 40 x 32   | 587,87             |                 |  |  |
| M 52x3,00   | 49,00   | D 225 x 50 x 40 x 32   | 604,18             |                 |  |  |
| <b>M 52x5,00</b>  | <b>47,00</b>  | D 250 x 65 x 40 x 32   | 395,14             | 470,78          |  |  |

\*Consultez le prix des tarauds à gauche disponibles à la page 217

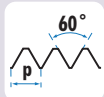
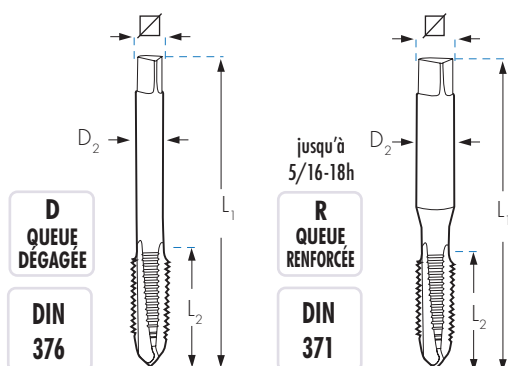
## TARAUDS MACHINE HSSCo

UNC

HSSCo  
5%TOL  
2BVc  
12 m/min

|  | D1<br>mm |  | L1 x L2 x D2 x $\nabla$<br>mm | M1R                | M2R             | M4R  |
|---|----------|---|-------------------------------|--------------------|-----------------|--|
|   |          |   |                               | ENTRÉE DROITE<br>€ | ENTRÉE GUN<br>€ |  35°<br>€ |
| UNC n° 4-40h  | 2,84     | 2,25  | R 56 x 11 x 3,5 x 2,7         | 13,64              | 16,38           | 20,62  |
| UNC n° 5-40h  | 3,17     | 2,60  | R 56 x 11 x 3,5 x 2,7         | 14,27              | 17,12           | 20,62  |
| UNC n° 6-32h  | 3,50     | 2,75  | R 56 x 12 x 4,0 x 3,0         | 14,28              | 17,16           | 21,50  |
| UNC n° 8-32h  | 4,17     | 3,50  | R 63 x 13 x 4,5 x 3,4         | 14,28              | 17,16           | 20,55  |
| UNC n° 10-24h   | 4,83     | 3,90  | R 70 x 15 x 6,0 x 4,9         | 14,27              | 17,12           | 21,56  |
| UNC n° 12-24h   | 5,49     | 4,50  | R 80 x 16 x 6,0 x 4,9         | 14,97              | 17,12           | 20,72  |
| UNC 1/4-20h   | 6,35     | 5,10  | R 80 x 17 x 7,0 x 5,5         | 15,64              | 17,06           | 21,70  |
| UNC 5/16-18h  | 7,94     | 6,60  | R 90 x 20 x 8,0 x 6,2         | 19,51              | 21,52           | 26,13  |

| QUEUE DÉGAGÉE |       |       | M1D                      | M2D    | M4D    |        |
|---------------|-------|-------|--------------------------|--------|--------|--------|
| UNC 3/8-16h   | 9,52  | 8,00  | D 100 x 22 x 7,0 x 5,5   | 21,97  | 23,02  | 27,61  |
| UNC 7/16-14h  | 11,11 | 9,40  | D 100 x 22 x 8,0 x 6,2   | 28,59  | 28,67  | 36,39  |
| UNC 1/2-13h   | 12,70 | 10,75 | D 110 x 24 x 9,0 x 7,0   | 26,14  | 28,98  | 36,43  |
| UNC 9/16-12h  | 14,28 | 12,20 | D 110 x 26 x 11,0 x 9,0  | 42,04  | 46,15  | 51,74  |
| UNC 5/8-11h   | 15,87 | 13,50 | D 110 x 27 x 12,0 x 9,0  | 40,83  | 44,95  | 62,89  |
| UNC 3/4-10h   | 19,05 | 16,50 | D 125 x 30 x 14,0 x 11,0 | 66,58  | 73,19  | 83,27  |
| UNC 7/8-9h    | 22,22 | 19,50 | D 140 x 32 x 18,0 x 14,5 | 87,60  | 96,25  | 125,77 |
| UNC 1"-8h     | 25,40 | 22,25 | D 160 x 36 x 18,0 x 14,5 | 115,75 | 126,46 | 142,39 |
| UNC 1.1/8-7h  | 28,57 | 25,00 | D 180 x 40 x 22,0 x 18,0 | 144,61 |        | 174,71 |
| UNC 1.1/4-7h  | 31,75 | 28,00 | D 180 x 40 x 22,0 x 18,0 | 169,54 |        | 223,50 |
| UNC 1.3/8-6h  | 34,92 | 30,75 | D 200 x 50 x 28,0 x 22,0 | 242,33 |        |        |
| UNC 1.1/2-6h  | 38,10 | 34,00 | D 200 x 50 x 32,0 x 24,0 | 287,15 |        |        |

TARAUDS MACHINE HSSCo

UNF

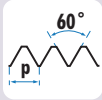

HSSCo  
5%

TOL  
2B

Vc  
12 m/min

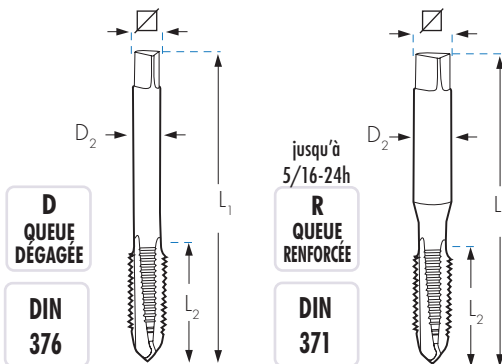

| UNF n°        | D <sub>1</sub> mm | D <sub>2</sub> mm | R | L <sub>1</sub> x L <sub>2</sub> x D <sub>2</sub> x ∅ mm | M1R           | M2R        | M4R   |
|---------------|-------------------|-------------------|---|---|---------------|------------|-------|
|               |                   |                   |   |   | ENTRÉE DROITE | ENTRÉE GUN | 35°   |
|               |                   |                   |   |   | €             | €          | €     |
| UNF n° 4-48h  | 2,84              | 2,35              | R | 56 x 11 x 3,5 x 2,7                                     | 14,97         | 16,30      | 20,63 |
| UNF n° 5-44h  | 3,17              | 2,70              | R | 56 x 11 x 3,5 x 2,7                                     | 14,97         | 16,30      | 20,63 |
| UNF n° 6-40h  | 3,50              | 2,95              | R | 56 x 12 x 4,0 x 3,0                                     | 13,57         | 16,26      | 20,65 |
| UNF n° 8-36h  | 4,17              | 3,50              | R | 63 x 13 x 4,5 x 3,4                                     | 13,57         | 16,26      | 20,65 |
| UNF n° 10-32h | 4,83              | 4,10              | R | 70 x 15 x 6,0 x 4,9                                     | 13,57         | 16,26      | 20,65 |
| UNF n° 12-28h | 5,49              | 4,60              | R | 80 x 16 x 6,0 x 4,9                                     | 13,68         | 16,39      | 20,63 |
| UNF 1/4-28h   | 6,35              | 5,50              | R | 80 x 17 x 7,0 x 5,5                                     | 15,22         | 16,30      | 20,57 |
| UNF 5/16-24h  | 7,94              | 6,90              | R | 90 x 20 x 8,0 x 6,2                                     | 17,96         | 20,55      | 24,92 |

| QUEUE DÉGAGÉE |           |       |       | M1D | M2D    | M4D    |        |
|---------------|-----------|-------|-------|-----|--------|--------|--------|
| UNF           | n°        | D     | D     |     |        |        |        |
| UNF           | 3/8-24h   | 9,52  | 8,50  | D   | 19,92  | 23,02  | 28,59  |
| UNF           | 7/16-20h  | 11,11 | 9,90  | D   | 22,65  | 27,33  | 36,17  |
| UNF           | 1/2-20h   | 12,70 | 11,50 | D   | 22,80  | 27,44  | 36,51  |
| UNF           | 9/16-18h  | 14,29 | 12,90 | D   | 34,17  | 41,18  | 51,91  |
| UNF           | 5/8-18h   | 15,87 | 14,50 | D   | 34,31  | 41,29  | 58,00  |
| UNF           | 3/4-16h   | 19,05 | 17,50 | D   | 51,87  | 62,47  | 74,21  |
| UNF           | 7/8-14h   | 22,22 | 20,40 | D   | 65,22  | 78,56  | 113,49 |
| UNF           | 1"-12h    | 25,40 | 23,25 | D   | 79,36  | 100,06 | 124,01 |
| UNS           | 1"-14h    | 25,40 | 23,60 | D   | 87,47  | 102,92 | 133,56 |
| UNF           | 1.1/8-12h | 28,57 | 26,50 | D   | 139,97 |        |        |
| UNF           | 1.1/4-12h | 31,75 | 29,50 | D   | 176,90 |        |        |
| UNF           | 1.1/2-12h | 38,10 | 36,00 | D   | 296,88 |        |        |

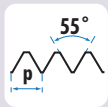
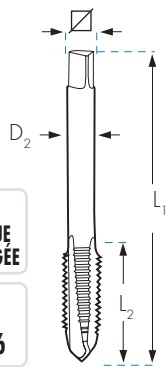
**TARAUDS MACHINE HSSCo**
**BSP  
(GAS)**

**HSSCo  
5%**
**TOL  
ISO 228**
**INOX**

**D  
QUEUE  
DÉGAGÉE**
**DIN  
5156**
**Vc  
12 m/min**
**Vc  
6 m/min**

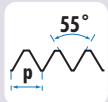
|              |        | D1<br>mm |   | L1 x L2 x D2 x $\nabla$<br>mm | M1D           |            | M2D           |            | M3D           |            | M4D           |            | M2DX          |            | M4DX          |            |
|--------------|--------|----------|---|-------------------------------|---------------|------------|---------------|------------|---------------|------------|---------------|------------|---------------|------------|---------------|------------|
|              |        |          |   |                               | ENTRÉE DROITE | ENTRÉE GUN | ENTRÉE DROITE | ENTRÉE GUN | ENTRÉE DROITE | ENTRÉE GUN | ENTRÉE DROITE | ENTRÉE GUN | ENTRÉE DROITE | ENTRÉE GUN | ENTRÉE DROITE | ENTRÉE GUN |
| €            | €      | €        | € | €                             | €             | €          | €             | €          | €             | €          | €             | €          | €             | €          | €             |            |
| G 1/8-28h.   | 9,728  | 8,80     | D | 90 x 16 x 7 x 5,5             | 26,95*        | 30,79      | 31,25         | 32,69      |               |            |               |            | 42,13         | 47,31      |               |            |
| G 1/4-19h.   | 13,157 | 11,80    | D | 100 x 22 x 11 x 9,0           | 34,86*        | 38,39      | 44,88         | 46,51      |               |            |               |            | 51,83         | 58,54      |               |            |
| G 3/8-19h.   | 16,662 | 15,25    | D | 100 x 22 x 12 x 9,0           | 42,79*        | 47,07      | 53,58         | 56,04      |               |            |               |            | 61,47         | 74,36      |               |            |
| G 1/2-14h.   | 20,955 | 19,00    | D | 125 x 25 x 16 x 12,0          | 56,56*        | 62,22      | 67,60         | 69,23      |               |            |               |            | 89,97         | 103,65     |               |            |
| G 5/8-14h.   | 22,911 | 21,00    | D | 125 x 25 x 18 x 14,5          | 70,47*        | 73,91      | 84,16         | 82,44      |               |            |               |            |               |            |               |            |
| G 3/4-14h.   | 26,441 | 24,50    | D | 140 x 28 x 20 x 16,0          | 88,53         | 97,42      | 105,80        | 110,65     |               |            |               |            | 144,83        | 190,69     |               |            |
| G 7/8-14h.   | 30,201 | 28,25    | D | 150 x 28 x 22 x 18,0          | 95,75         | 100,72     | 142,29        | 142,29     |               |            |               |            |               |            |               |            |
| G 1"-11h.    | 33,249 | 30,75    | D | 160 x 30 x 25 x 20,0          | 137,41        | 151,12     | 162,46        | 169,92     |               |            |               |            |               |            |               |            |
| G 1.1/8-11h. | 37,897 | 35,50    | D | 170 x 30 x 28 x 22,0          | 189,34        | 206,52     |               | 251,44     |               |            |               |            |               |            |               |            |
| G 1.1/4-11h. | 41,910 | 39,50    | D | 170 x 30 x 32 x 24,0          | 234,16        | 246,38     |               | 265,75     |               |            |               |            |               |            |               |            |
| G 1.3/8-11h. | 44,323 | 42,00    | D | 180 x 32 x 36 x 29,0          | 294,48        |            |               | 398,45     |               |            |               |            |               |            |               |            |
| G 1.1/2-11h. | 47,803 | 45,25    | D | 190 x 32 x 36 x 29,0          | 258,50        | 360,35     |               | 388,80     |               |            |               |            |               |            |               |            |
| G 1.3/4-11h. | 53,746 | 51,25    | D | 190 x 32 x 40 x 32,0          | 466,77        | 449,83     |               |            |               |            |               |            |               |            |               |            |
| G 2"-11h.    | 59,614 | 57,00    | D | 220 x 36 x 45 x 35,0          | 595,32        | 600,07     |               |            |               |            |               |            |               |            |               |            |

\* Disponible également en pas à gauche: doubler le prix du pas à droite

**BSF**

**HSSCo  
5%**
**TOL  
ISO 228**
**Vc  
12 m/min**
**D  
QUEUE  
DÉGAGÉE**
**DIN  
5156**

|               |        | D1<br>mm |   | L1 x L2 x D2 x $\nabla$<br>mm | M1D           |
|---------------|--------|----------|---|-------------------------------|---------------|
|               |        |          |   |                               | ENTRÉE DROITE |
| €             | €      | €        | € | €                             | €             |
| BSF 3/16-32h. | 4,762  | 4,00     | D | 70 x 16 x 3,5 x 2,7           | 63,06         |
| BSF 1/4-26h.  | 6,350  | 5,20     | D | 80 x 17 x 4,5 x 3,4           | 27,58         |
| BSF 5/16-22h. | 7,938  | 6,60     | D | 90 x 20 x 6,0 x 4,9           | 32,76         |
| BSF 3/8-20h.  | 9,525  | 8,10     | D | 100 x 22 x 7,0 x 5,5          | 34,43         |
| BSF 7/16-18h. | 11,113 | 9,50     | D | 100 x 22 x 8,0 x 6,2          | 46,40         |
| BSF 1/2-16h.  | 12,700 | 11,00    | D | 110 x 24 x 9,0 x 7,0          | 52,51         |
| BSF 9/16-16h. | 14,287 | 12,50    | D | 110 x 25 x 11,0 x 9,0         | 55,57         |
| BSF 5/8-14h.  | 15,876 | 14,00    | D | 110 x 27 x 12,0 x 9,0         | 74,08         |
| BSF 3/4-12h.  | 19,051 | 16,50    | D | 125 x 30 x 14,0 x 11,0        | 87,69         |
| BSF 7/8-11h.  | 22,226 | 19,50    | D | 140 x 32 x 18,0 x 14,5        | 121,88        |
| BSF 1"-10h.   | 25,400 | 22,50    | D | 160 x 36 x 18,0 x 14,5        | 141,68        |

TARAUDS MACHINE HSSCo

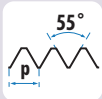
BSW



HSSCo  
5%

TOL  
Classe 2

Vc  
12 m/min

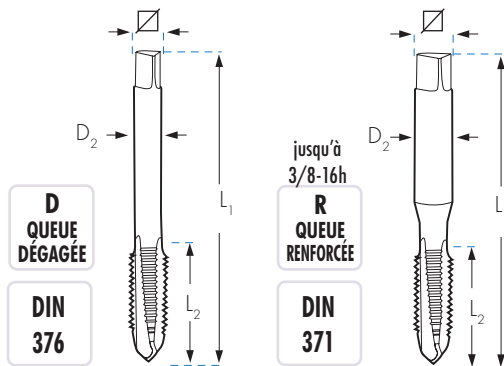

| D1 mm       | L1 x L2 x D2 x mm                 | M1R    | M2R   | M3R   | M4R   |
|-------------|-----------------------------------|--------|-------|-------|-------|
|             |                                   |        |       |       |       |
| W 3/32-48h. | 2,38 1,80 R 50 x 9 x 2,8 x 2,1    | 19,62  | 19,12 |       |       |
| W 1/8-40h.  | 3,17 2,55 R 56 x 11 x 3,5 x 2,7   | 15,52* | 17,15 | 18,62 | 19,48 |
| W 5/32-32h. | 3,97 3,10 R 63 x 13 x 4,5 x 3,4   | 15,52  | 17,15 | 18,62 | 19,48 |
| W 3/16-24h. | 4,76 3,60 R 70 x 15 x 6,0 x 4,9   | 19,26  | 19,36 | 18,62 | 19,48 |
| W 7/32-24h. | 5,56 4,40 R 80 x 16 x 6,0 x 4,9   | 23,56  | 24,92 |       |       |
| W 1/4-20h.  | 6,35 5,10 R 80 x 17 x 7,0 x 5,5   | 16,59  | 17,33 | 21,15 | 21,83 |
| W 5/16-18h. | 7,94 6,50 R 90 x 20 x 8,0 x 6,2   | 19,72  | 21,97 | 24,67 | 25,80 |
| W 3/8-16h.  | 9,52 7,90 R 100 x 22 x 10,0 x 8,0 | 20,80  | 24,58 | 27,40 | 28,66 |

| QUEUE DÉGAGÉE |                                      |  | M1D    | M2D    | M3D    | M4D    |
|---------------|--------------------------------------|--|--------|--------|--------|--------|
| W 7/16-14h.   | 11,11 9,25 D 100 x 22 x 8,0 x 6,2    |  | 28,94  | 30,62  | 36,20  | 36,45  |
| W 1/2-12h.    | 12,70 10,50 D 110 x 24 x 9,0 x 7,0   |  | 27,75  | 29,37  | 34,68  | 36,27  |
| W 9/16-12h.   | 14,29 12,00 D 110 x 26 x 11,0 x 9,0  |  | 39,78  | 41,80  | 49,74  | 52,02  |
| W 5/8-11h.    | 15,87 13,40 D 110 x 27 x 12,0 x 9,0  |  | 37,67  | 41,37  | 47,02  | 49,18  |
| W 3/4-10h.    | 19,05 16,50 D 125 x 30 x 14,0 x 11,0 |  | 52,71  | 58,00  | 63,02  | 65,91  |
| W 7/8-9h.     | 22,22 19,25 D 140 x 32 x 18,0 x 14,5 |  | 68,26  | 75,06  | 85,29  | 85,29  |
| W 1"-8h.      | 25,40 21,75 D 160 x 36 x 18,0 x 14,5 |  | 85,80  | 94,32  | 107,04 | 111,95 |
| W 1.1/8-7h.   | 28,57 24,75 D 180 x 40 x 22,0 x 18,0 |  | 116,36 | 122,36 | 187,15 |        |
| W 1.1/4-7h.   | 31,75 27,75 D 180 x 40 x 22,0 x 18,0 |  | 169,04 | 177,79 |        |        |
| W 1.3/8-6h.   | 34,92 30,50 D 200 x 50 x 28,0 x 22,0 |  | 277,86 | 291,96 |        |        |
| W 1.1/2-6h.   | 38,10 33,50 D 200 x 50 x 32,0 x 24,0 |  | 301,59 | 317,19 |        |        |
| W 1.5/8-5h.   | 41,27 46,50 D 220 x 65 x 32,0 x 24,0 |  | 420,96 | 442,76 |        |        |
| W 1.3/4-5h.   | 44,45 39,00 D 220 x 58 x 36,0 x 29,0 |  | 434,21 | 477,66 |        |        |
| W 1.7/8-4,5h. | 47,62 42,00 D 250 x 75 x 36,0 x 29,0 |  | 503,47 | 529,53 |        |        |
| W 2"-4,5h.    | 50,80 44,50 D 250 x 65 x 40,0 x 32,0 |  | 621,46 |        |        |        |

\* Disponible également en pas à gauche: doubler le prix du pas à droite

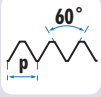
**TARAUDS MACHINE HSSCo**
**UNJC**

**HSSCo**  
 5%

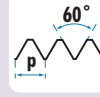
**TOL**  
 3B

**UNJF**

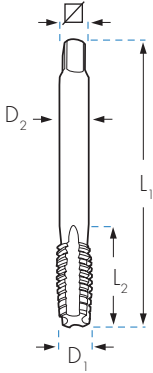
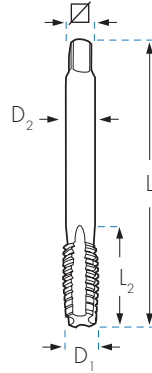
**HSSCo**  
 5%

**TOL**  
 3B

**Vc**  
 12 m/min

**Vc**  
 12 m/min

|               | D1<br>mm | D2<br>mm | R | L1 x L2 x D2 x $\nabla$<br>mm | MIR                   |
|---------------|----------|----------|---|-------------------------------|-----------------------|
|               |          |          |   |                               | ENTRÉE<br>DROITE<br>€ |
| UNJC n° 4-40h | 2,84     | 2,25     | R | 56 x 11 x 3,5 x 2,7           | 38,94                 |
| UNJC n° 5-40h | 3,17     | 2,60     | R | 56 x 11 x 3,5 x 2,7           | 38,94                 |
| UNJC n° 6-32h | 3,50     | 2,75     | R | 56 x 12 x 4,0 x 3,0           | 38,94                 |
| UNJC n° 8-32h | 4,17     | 3,50     | R | 63 x 13 x 4,5 x 3,4           | 38,94                 |
| UNJC n°10-24h | 4,83     | 3,90     | R | 70 x 15 x 6,0 x 4,9           | 38,94                 |
| UNJC n°12-24h | 5,49     | 4,50     | R | 80 x 16 x 6,0 x 4,9           | 40,85                 |
| UNJC 1/4-20h  | 6,35     | 5,10     | R | 80 x 17 x 7,0 x 5,5           | 36,34                 |
| UNJC 5/16-18h | 7,94     | 6,60     | R | 90 x 20 x 8,0 x 6,2           | 41,12                 |
| UNJC 3/8-16h  | 9,52     | 8,00     | R | 100 x 22 x 8,0 x 6,2          | 46,88                 |

|               | D1<br>mm | D2<br>mm | R | L1 x L2 x D2 x $\nabla$<br>mm | MIR                   |
|---------------|----------|----------|---|-------------------------------|-----------------------|
|               |          |          |   |                               | ENTRÉE<br>DROITE<br>€ |
| UNJF n° 4-48h | 2,84     | 2,35     | R | 56 x 11 x 3,5 x 2,7           | 42,72                 |
| UNJF n° 5-44h | 3,17     | 2,70     | R | 56 x 11 x 3,5 x 2,7           | 42,72                 |
| UNJF n° 6-40h | 3,50     | 2,95     | R | 56 x 12 x 4,0 x 3,0           | 42,72                 |
| UNJF n° 8-36h | 4,17     | 3,50     | R | 63 x 13 x 4,5 x 3,4           | 42,72                 |
| UNJF n°10-32h | 4,83     | 4,10     | R | 70 x 15 x 6,0 x 4,9           | 42,72                 |
| UNJF n°12-28h | 5,49     | 4,60     | R | 80 x 16 x 6,0 x 4,9           | 42,72                 |
| UNJF 1/4-28h  | 6,35     | 5,50     | R | 80 x 17 x 7,0 x 5,5           | 33,17                 |
| UNJF 5/16-24h | 7,94     | 6,90     | R | 90 x 20 x 8,0 x 6,2           | 37,09                 |
| UNJF 3/8-24h  | 9,52     | 8,50     | R | 90 x 16 x 7,0 x 6,2           | 40,61                 |

| QUEUE DÉGAGÉE |       |       |   | M1D                    |        |
|---------------|-------|-------|---|------------------------|--------|
| UNJC 7/16-14h | 11,11 | 9,40  | D | 110 x 24 x 9,0 x 7,0   | 64,65  |
| UNJC 1/2-13h  | 12,70 | 10,75 | D | 110 x 26 x 11,0 x 9,0  | 70,18  |
| UNJC 9/16-12h | 14,28 | 12,20 | D | 110 x 27 x 12,0 x 9,0  | 96,44  |
| UNJC 5/8-11h  | 15,87 | 13,50 | D | 110 x 27 x 12,0 x 9,0  | 110,05 |
| UNJC 3/4-10h  | 19,05 | 16,50 | D | 125 x 30 x 14,0 x 11,0 | 124,05 |
| UNJC 7/8-9h   | 22,22 | 19,50 | D | 140 x 32 x 18,0 x 14,5 | 163,22 |
| UNJC 1"-8h    | 25,40 | 22,25 | D | 160 x 36 x 18,0 x 14,5 | 215,66 |

| QUEUE DÉGAGÉE |       |       |   | M1D                    |        |
|---------------|-------|-------|---|------------------------|--------|
| UNJF 7/16-20h | 11,11 | 9,90  | D | 100 x 22 x 8,0 x 6,2   | 55,77  |
| UNJF 1/2-20h  | 12,70 | 11,50 | D | 100 x 22 x 9,0 x 7,0   | 59,39  |
| UNJF 9/16-18h | 14,29 | 12,90 | D | 100 x 22 x 11,0 x 9,0  | 72,96  |
| UNJF 5/8-18h  | 15,87 | 14,50 | D | 100 x 22 x 12,0 x 9,0  | 82,15  |
| UNJF 3/4-16h  | 19,05 | 17,50 | D | 110 x 25 x 14,0 x 11,0 | 105,10 |
| UNJF 7/8-14h  | 22,22 | 20,40 | D | 125 x 25 x 18,0 x 14,5 | 132,17 |
| UNJF 1"-12h   | 25,40 | 23,25 | D | 140 x 28 x 18,0 x 14,5 | 147,35 |



**TARAUDS MACHINE HSSCo**

**BSPB** **DIN 2999** **55°** **HSSCo 5%** **DIN 374** **ENTRÉE DROITE**

**BSPT** **BS21 ISO7/1** **55°** **HSSCo 5%** **DIN 5156** **ENTRÉE DROITE**

PAS POUR TUBE  
CYLINDRIQUE

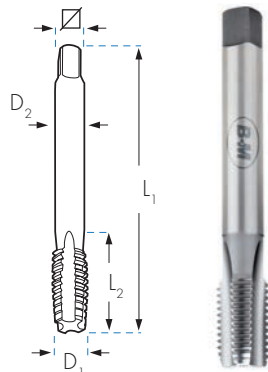

PAS POUR TUBE  
CONIQUE

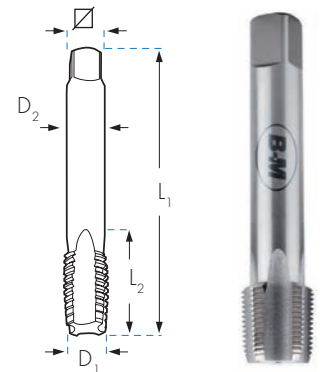

|               | D1<br>mm | L1 x L2 x D2 x ∅<br>mm | MTD<br>€ |
|---------------|----------|------------------------|----------|
| Rp 1/16-28h.  | 7,72     | D 90 x 16 x 6 x 4,9    |          |
| Rp 1/8-28h.   | 9,73     | D 90 x 16 x 7 x 5,5    | 46,89    |
| Rp 1/4-19h.   | 13,16    | D 100 x 22 x 11 x 9,0  | 64,78    |
| Rp 3/8-19h.   | 16,66    | D 100 x 22 x 12 x 9,0  | 77,56    |
| Rp 1/2-14h.   | 20,95    | D 125 x 25 x 16 x 12,0 | 98,03    |
| Rp 3/4-14h.   | 26,44    | D 140 x 28 x 20 x 16,0 | 153,50   |
| Rp 1"-11h.    | 33,25    | D 160 x 30 x 25 x 20,0 | 238,15   |
| Rp 1.1/4-11h. | 41,91    | D 170 x 30 x 32 x 24,0 |          |
| Rp 1.1/2-11h. | 46,80    | D 190 x 32 x 36 x 29,0 |          |
| Rp 2"-11h.    | 59,61    | D 220 x 36 x 45 x 35,0 |          |

|              | D1<br>mm | ∅     | L1 x L2 x D2 x ∅<br>mm | MTD<br>€ |
|--------------|----------|-------|------------------------|----------|
| Rc 1/16-28h. | 7,72     |       | D 90 x 14 x 6 x 4      |          |
| Rc 1/8-28h.  | 9,73     | 8,30  | D 90 x 15 x 7 x 5      | 49,83    |
| Rc 1/4-19h.  | 13,16    | 11,00 | D 100 x 19 x 11 x 9    | 71,65    |
| Rc 3/8-19h.  | 16,66    | 14,50 | D 100 x 21 x 12 x 9    | 99,59    |
| Rc 1/2-14h.  | 20,95    | 18,10 | D 125 x 26 x 16 x 12   | 138,37   |
| Rc 5/8-14h.  | 22,91    | 21,00 | D 140 x 36 x 18 x 19   | 214,94   |
| Rc 3/4-14h.  | 26,44    | 23,50 | D 140 x 28 x 20 x 16   | 153,23   |
| Rc 7/8-14h.  | 30,20    | 28,25 | D 160 x 36 x 22 x 18   | 375,55   |
| Rc 1"-11h.   | 33,25    | 29,60 | D 160 x 33 x 25 x 20   | 284,57   |

**NPS (M)** **ANSI B 1.20.1** **60°** **HSSCo 5%** **DIN 374** **ENTRÉE DROITE**

**NPT** **ANSI B 1.20.1** **60°** **HSSCo 5%** **DIN 374** **ENTRÉE DROITE**

PAS POUR TUBE  
AMÉRICAIN CYLINDRIQUE

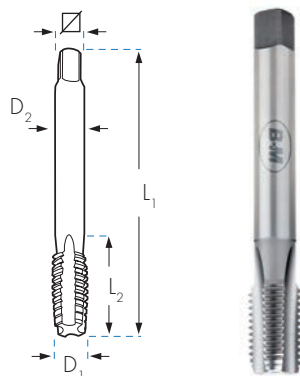

PAS POUR TUBE  
AMÉRICAIN CONIQUE

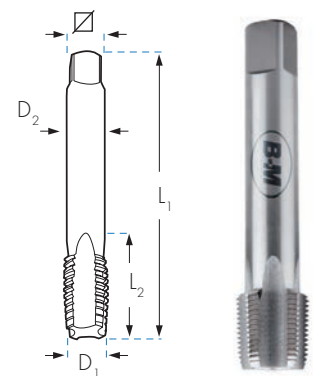

|                  | D1<br>mm | ∅     | L1 x L2 x D2 x ∅<br>mm | MTD<br>€ |
|------------------|----------|-------|------------------------|----------|
| NPS 1/8-27h.     | 10,20    | 8,90  | D 90 x 16 x 7 x 5,5    | 125,44   |
| NPS 1/4-18h.     | 13,60    | 11,70 | D 100 x 22 x 11 x 9,0  | 179,51   |
| NPS 3/8-18h.     | 17,00    | 15,00 | D 100 x 22 x 12 x 9,0  | 246,19   |
| NPS 1/2-14h.     | 21,20    | 18,60 | D 125 x 25 x 16 x 12,0 | 337,59   |
| NPS 3/4-14h.     | 26,55    | 24,00 | D 140 x 28 x 20 x 16,0 | 499,05   |
| NPS 1"-11,5 h.   | 33,20    | 30,00 | D 160 x 30 x 25 x 20,0 | 645,36   |
| NPS 1.1/4-11,5h. | 41,60    |       | D 170 x 30 x 32 x 24,0 |          |
| NPS 1.1/2-11,5h. | 47,68    |       | D 190 x 32 x 36 x 29,0 |          |
| NPS 2"-11,5h.    | 59,71    |       | D 220 x 36 x 45 x 35,0 |          |

|                  | D1<br>mm | ∅    | L1 x L2 x D2 x ∅<br>mm | MTD<br>€ |
|------------------|----------|------|------------------------|----------|
| NPT 1/16-27h.    | 7,89     | 6,2  | D 90 x 14 x 6 x 5      | 40,48    |
| NPT 1/8-27h.     | 10,24    | 8,5  | D 90 x 15 x 8 x 6      | 42,35    |
| NPT 1/4-18h.     | 13,62    | 11,0 | D 100 x 19 x 11 x 9    | 56,77    |
| NPT 3/8-18h.     | 17,05    | 14,5 | D 100 x 21 x 12 x 9    | 72,99    |
| NPT 1/2-14h.     | 21,22    | 17,8 | D 125 x 26 x 16 x 12   | 94,94    |
| NPT 3/4-14h.     | 26,57    | 23,0 | D 140 x 28 x 20 x 16   | 147,11   |
| NPT 1"-11,5h.    | 33,23    | 29,0 | D 160 x 33 x 25 x 20   | 191,19   |
| NPT 1.1/4-11,5h. | 41,98    | 37,5 | D 170 x 36 x 32 x 24   | 251,47   |
| NPT 1.1/2-11,5h. | 48,05    | 44,0 | D 190 x 37 x 36 x 29   | 411,06   |
| NPT 2"-11,5h.    | 60,09    | 56,0 | D 220 x 41 x 45 x 35   | 644,79   |

## TARAUDS MACHINE HSSCo

NPSF

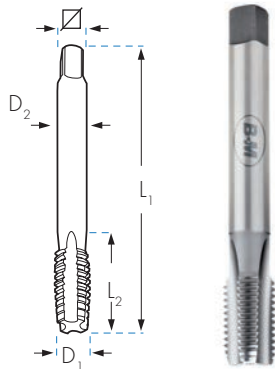
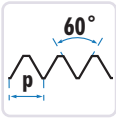
HSSCo  
5%DIN  
374ENTRÉE  
DROITEPAS POUR TUBE  
AMÉRICAIN CYLINDRIQUE

NPTF

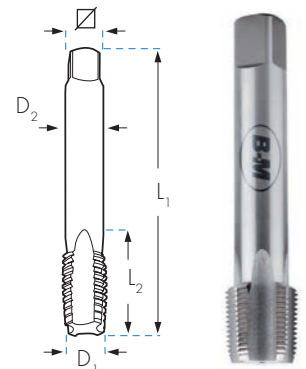
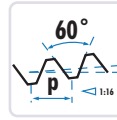
HSSCo  
5%DIN  
374ENTRÉE  
DROITEPAS POUR TUBE  
AMÉRICAIN CYLINDRIQUE  
ÉTANCHE

|                | D1<br>mm |       | L1 x L2 x D2 x $\square$<br>mm | MID<br>€ |
|----------------|----------|-------|--------------------------------|----------|
| NPSF 1/8-27h.  | 10,05    | 8,75  | D 90 x 16 x 7 x 5,5            | 151,30   |
| NPSF 1/4-18h.  | 13,33    | 11,30 | D 100 x 22 x 11 x 9,0          | 208,56   |
| NPSF 3/8-18h.  | 16,78    | 14,70 | D 100 x 22 x 12 x 9,0          | 296,67   |
| NPSF 1/2-14h.  | 20,87    | 18,20 | D 125 x 25 x 16 x 12,0         | 369,96   |
| NPSF 3/4-14h.  | 26,23    | 23,50 | D 140 x 28 x 20 x 16,0         | 605,50   |
| NPSF 1"-11,5h. | 32,81    | 29,50 | D 160 x 30 x 25 x 20,0         |          |

|                | D1<br>mm |       | L1 x L2 x D2 x $\square$<br>mm | MID<br>€ |
|----------------|----------|-------|--------------------------------|----------|
| NPTF 1/16-27h. | 7,87     | 6,20  | D 90 x 14 x 12,0 x 6           |          |
| NPTF 1/8-27h.  | 10,22    | 8,50  | D 90 x 15 x 12,0 x 7           | 102,23   |
| NPTF 1/4-18h.  | 13,58    | 11,00 | D 100 x 21 x 17,5 x 11         | 143,41   |
| NPTF 3/8-18h.  | 17,02    | 14,50 | D 110 x 21 x 17,6 x 12         | 184,24   |
| NPTF 1/2-14h.  | 21,21    | 17,80 | D 140 x 27 x 22,8 x 16         | 239,84   |
| NPTF 3/4-14h.  | 26,56    | 23,00 | D 140 x 27 x 23,0 x 20         | 371,55   |

MF

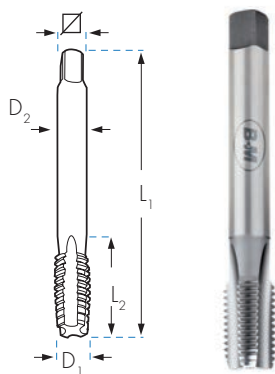
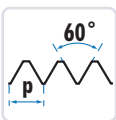
HSSCo  
5%TOL  
6HENTRÉE  
DROITEDIN  
374PAS MÉTRIQUE FINE POUR  
TUBES DE CONDUITE  
ÉLECTRIQUE EN 60423

PG

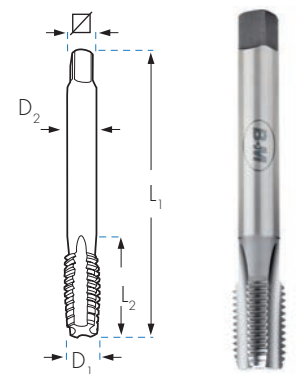
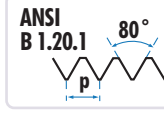
HSSCo  
5%DIN  
40430ENTRÉE  
DROITEPAS POUR TUBES DE  
CONDUITE ÉLECTRIQUE

|              | D1<br>mm |      | L1 x L2 x D2 x $\square$<br>mm | MID<br>€ |
|--------------|----------|------|--------------------------------|----------|
| MF 12 x 1,50 | 12       | 10,5 | D 100 x 22 x 9 x 7,0           | 24,11    |
| MF 16 x 1,50 | 16       | 14,5 | D 100 x 22 x 12 x 9,0          | 33,96    |
| MF 20 x 1,50 | 20       | 18,5 | D 125 x 25 x 16 x 12,0         | 50,91    |
| MF 25 x 1,50 | 25       | 23,5 | D 140 x 28 x 18 x 14,5         | 110,73   |
| MF 32 x 1,50 | 32       | 30,5 | D 150 x 28 x 22 x 18,0         | 146,35   |
| MF 40 x 1,50 | 40       | 38,5 | D 170 x 30 x 32 x 24,0         | 244,25   |
| MF 50 x 1,50 | 50       | 48,5 | D 190 x 32 x 36 x 29,0         | 383,76   |
| MF 63 x 1,50 | 63       | 61,5 | D 275 x 36 x 50 x 39,0         |          |

|                | D1<br>mm |       | L1 x L2 x D2 x $\square$<br>mm | MID<br>€ |
|----------------|----------|-------|--------------------------------|----------|
| PG 7 - 20h.    | 12,5     | 11,50 | D 100 x 22 x 9 x 7,0           | 44,86    |
| PG 9 - 18h.    | 15,2     | 14,00 | D 100 x 22 x 12 x 9,0          | 62,12    |
| PG 11 - 18h.   | 18,6     | 17,25 | D 110 x 25 x 14 x 11,0         | 80,84    |
| PG 13,5 - 18h. | 20,4     | 19,00 | D 125 x 25 x 16 x 12,0         | 90,77    |
| PG 16 - 18h.   | 22,5     | 21,25 | D 125 x 25 x 18 x 14,5         | 106,82   |
| PG 21 - 16h.   | 28,3     | 27,00 | D 150 x 28 x 22 x 18,0         | 169,59   |
| PG 29 - 16h.   | 37,0     | 35,50 | D 170 x 30 x 28 x 22,0         | 286,68   |
| PG 36 - 16h.   | 47,0     | 45,50 | D 190 x 32 x 36 x 29,0         | 465,59   |
| PG 42 - 16h.   | 54,0     | 52,50 | D 190 x 32 x 40 x 32,0         | 739,46   |
| PG 48 - 16h.   | 59,3     | 58,00 | D 220 x 36 x 45 x 35,0         | 901,45   |

TARAUDS MACHINE HSSCo

**UNx8** HSSCo 5% DIN 374 ENTRÉE DROITE TOL 2B

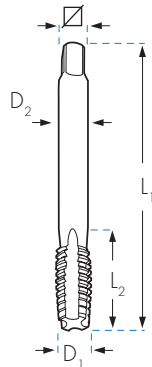
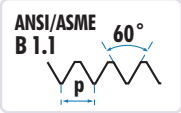

**UNEF** HSSCo 5% DIN 374 TOL 2B

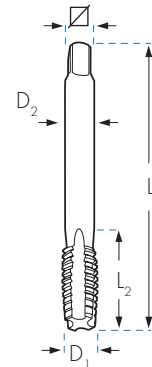
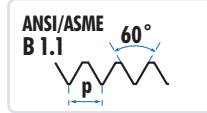

|               |       | D <sub>2</sub> mm | L <sub>1</sub> x L <sub>2</sub> x mm | M1D<br>ENTRÉE DROITE<br>€ |
|---------------|-------|-------------------|--------------------------------------|---------------------------|
| UN 1" 1/8-8h. | 25,40 | 22                | 180 x 45 x 18                        | 280,55                    |
| UN 1" 1/4-8h. | 28,50 | 22                | 180 x 48 x 18                        | 361,95                    |
| UN 1" 3/8-8h. | 31,75 | 28                | 200 x 56 x 22                        | 410,60                    |
| UN 1" 1/2-8h. | 35,00 | 32                | 200 x 58 x 22                        | 490,10                    |
| UN 1" 5/8-8h. | 38,10 | 32                | 200 x 65 x 24                        | 573,30                    |
| UN 1" 3/4-8h. | 41,25 | 36                | 200 x 50 x 29                        | 698,37                    |
| UN 1" 7/8-8h. | 44,45 | 36                | 225 x 53 x 29                        | 781,41                    |
| UN 2"-8h.     | 47,63 | 40                | 225 x 50 x 32                        | 823,11                    |

|                |       | D <sub>2</sub> mm | L <sub>1</sub> x L <sub>2</sub> x mm | M2D<br>ENTRÉE GUN<br>€ | M4D<br>35°<br>€ |
|----------------|-------|-------------------|--------------------------------------|------------------------|-----------------|
| UNEF 1/4-32h.  | 5,55  | 7,0               | R 82 x 16 x 5,4                      | 92,27                  | 103,69          |
| UNEF 5/16-32h. | 7,15  | 8,4               | R 85 x 21 x 6,1                      | 101,66                 | 114,24          |
| UNEF 3/8-32h.  | 8,70  | 7,0               | D 95 x 22 x 5,4                      | 101,72                 | 114,29          |
| UNEF 7/16-28h. | 10,20 | 8,0               | D 100 x 22 x 6,2                     | 135,01                 | 151,71          |
| UNEF 1/2-28h.  | 11,80 | 9,0               | D 100 x 22 x 7,0                     | 142,22                 | 159,80          |
| UNEF 9/16-24h. | 13,20 | 12,0              | D 100 x 24 x 9,0                     | 178,18                 | 200,19          |
| UNEF 5/8-24h.  | 14,80 | 12,0              | D 100 x 24 x 9,0                     | 202,74                 | 227,82          |
| UNEF 3/4-20h.  | 17,80 | 14,0              | D 110 x 27 x 11,0                    | 263,70                 | 296,30          |
| UNEF 7/8-20h.  | 20,95 | 18,0              | D 125 x 26 x 14,5                    | 283,45                 | 303,70          |
| UNEF 1"-20h.   | 24,20 | 18,0              | D 140 x 28 x 14,5                    | 433,77                 | 487,38          |

TARAUDS MACHINE HSSCo À GAUCHE

**M MF** HSSCo 5% ENTRÉE DROITE TOL 6H

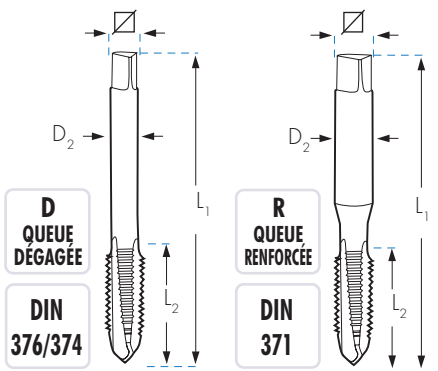
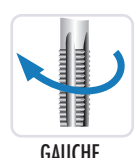
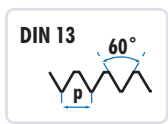



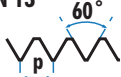
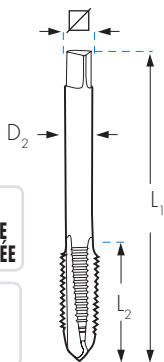
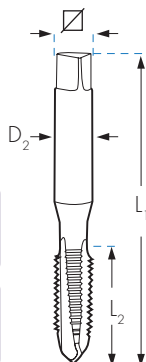

|           |      |                         | M1R1<br>ENTRÉE DROITE<br>€ |
|-----------|------|-------------------------|----------------------------|
| M 3x0,50  | 2,50 | R 56 x 11 x 3,5 x 2,7   | 21,57                      |
| M 4x0,70  | 3,30 | R 63 x 13 x 4,5 x 3,4   | 24,31                      |
| M 5x0,80  | 4,20 | R 70 x 16 x 6,0 x 4,9   | 22,01                      |
| M 6x1,00  | 5,00 | R 80 x 17 x 6,0 x 4,9   | 24,27                      |
| M 7x1,00  | 6,00 | R 80 x 17 x 7,0 x 5,5   | 32,76                      |
| M 8x1,25  | 6,80 | R 90 x 20 x 8,0 x 6,2   | 28,26                      |
| M 10x1,50 | 8,50 | R 100 x 22 x 10,0 x 8,0 | 31,44                      |

|           |       |                          | M1D1<br>ENTRÉE DROITE<br>€ |
|-----------|-------|--------------------------|----------------------------|
| M 12x1,50 | 10,50 | D 100 x 22 x 9,0 x 7,0   | 48,22                      |
| M 12x1,75 | 10,20 | D 110 x 24 x 9,0 x 7,0   | 34,43                      |
| M 14x1,50 | 12,50 | D 100 x 22 x 11,0 x 9,0  | 57,44                      |
| M 14x2,00 | 12,00 | D 110 x 26 x 11,0 x 9,0  | 57,03                      |
| M 16x1,50 | 14,50 | D 100 x 22 x 12,0 x 9,0  | 67,93                      |
| M 16x2,00 | 14,00 | D 110 x 27 x 12,0 x 9,0  | 67,12                      |
| M 18x1,50 | 16,50 | D 110 x 25 x 14,0 x 11,0 | 89,88                      |
| M 18x2,50 | 15,50 | D 125 x 30 x 14,0 x 11,0 | 96,57                      |
| M 20x1,50 | 18,50 | D 125 x 25 x 16,0 x 12,0 | 101,83                     |
| M 20x2,50 | 17,50 | D 140 x 32 x 16,0 x 12,0 | 102,79                     |
| M 22x2,50 | 19,50 | D 140 x 32 x 18,0 x 14,5 | 124,41                     |
| M 24x2,00 | 22,00 | D 140 x 28 x 18,0 x 14,5 | 192,28                     |
| M 24x3,00 | 21,00 | D 160 x 34 x 18,0 x 14,5 | 148,94                     |
| M 27x3,00 | 24,00 | D 160 x 36 x 20,0 x 16,0 | 185,91                     |
| M 30x2,00 | 28,00 | D 150 x 28 x 22,0 x 18,0 | 279,96                     |
| M 30x3,50 | 26,50 | D 180 x 40 x 22,0 x 18,0 | 238,25                     |
| M 33x3,50 | 29,50 | D 180 x 40 x 25,0 x 20,0 | 286,30                     |
| M 36x4,00 | 32,00 | D 200 x 50 x 28,0 x 22,0 | 361,86                     |

Autres dimensions disponibles sur demande

**TARAUDS MACHINE NORME ISO 529**
**M**  
**MF**
**DIN 13**

**HSSCo**  
**5%**
**ISO**  
**529**
**TOL**  
**6H**
**D**  
**QUEUE**  
**DEGAGÉE**  
  
**ISO**  
**529**

**R**  
**QUEUE**  
**RENFORCÉE**  
  
**ISO**  
**529**

|  |  | L <sub>1</sub> x L <sub>2</sub> x D <sub>2</sub> x <br>mm | M1RISO           | M2RISO        | M4RISO  | M5RISO   |
|---|---|--|------------------|---------------|---|--|
|   |   |  | ENTRÉE<br>DROITE | ENTRÉE<br>GUN |  35° | FILET<br>ALTERNÉ<br><span style="background-color: green; color: white; padding: 2px;">AI</span> |
|   |   |  | €                | €             | €   | €  |
| M 3x0,50  | 2,50  | R 48 x 11 x 3,15 x 2,50  | 8,10             | 8,44          | 10,17   | 10,96  |
| M 4x0,70  | 3,30  | R 53 x 13 x 4,00 x 3,15  | 8,10             | 8,44          | 10,17   | 10,96  |
| M 5x0,80  | 4,20  | R 58 x 16 x 5,00 x 4,00  | 8,10             | 8,44          | 10,17   | 10,96  |
| M 6x1,00  | 5,00  | R 66 x 19 x 6,30 x 5,00  | 8,10             | 8,44          | 10,39   | 10,96  |
| M 7x1,00  | 6,00  | R 66 x 19 x 7,10 x 5,60  |                  | 11,51         | 14,11   |  |
| M 8x1,00  | 7,00  | R 69 x 19 x 8,00 x 6,30  |                  | 14,90         | 15,38   |  |
| M 8x1,25  | 6,75  | R 72 x 22 x 8,00 x 6,30  | 10,81            | 11,27         | 11,65   | 11,98  |
| M 9x1,25  | 7,75  | R 76 x 20 x 10,00 x 8,00   |                  | 15,53         | 17,67   |  |
| M 10x1,00   | 9,00  | R 76 x 20 x 10,00 x 8,00   |                  | 17,10         | 18,69   |  |
| M 10x1,25   | 8,80  | R 76 x 20 x 10,00 x 8,00   |                  | 20,44         | 21,10   |  |
| M 10x1,50   | 8,50  | R 80 x 24 x 10,00 x 8,00   | 13,76            | 14,33         | 15,02   | 15,12  |
| <b>QUEUE DÉGAGÉE</b>  |   |  | M1DISO           | M2DISO        | M4DISO  | M5DISO   |
| M 12x1,00   | 11,00   | D 84 x 24 x 9,00 x 7,10  |                  | 25,45         | 25,82   |  |
| M 12x1,25   | 10,75   | D 84 x 24 x 9,00 x 7,10  |                  | 25,71         | 26,31   |  |
| M 12x1,50   | 10,50   | D 89 x 29 x 9,00 x 7,10  |                  | 22,95         | 23,78   |  |
| M 12x1,75   | 10,20   | D 89 x 29 x 9,00 x 7,10  | 16,01            | 18,41         | 19,51   | 22,61  |
| M 14x1,00   | 13,00   | D 90 x 25 x 11,20 x 9,00   |                  | 32,66         | 39,88   |  |
| M 14x1,25   | 12,80   | D 90 x 25 x 11,20 x 9,00   |                  | 28,64         | 36,00   |  |
| M 14x1,50   | 12,50   | D 95 x 30 x 12,50 x 9,00   |                  | 22,74         | 28,38   |  |
| M 14x2,00   | 12,00   | D 95 x 30 x 11,20 x 9,00   | 21,15            | 22,03         | 26,67   |  |
| M 16x1,00   | 15,00   | D 95 x 25 x 12,50 x 10,00  |                  | 44,72         | 46,18   |  |
| M 16x1,25   | 14,75   | D 102 x 32 x 12,50 x 10,00   |                  | 45,13         | 46,36   |  |
| M 16x1,50   | 14,50   | D 102 x 32 x 14,00 x 10,00   |                  | 31,65         | 35,54   |  |
| M 16x2,00   | 14,00   | D 102 x 32 x 12,50 x 10,00   | 26,25            | 27,35         | 30,93   |  |
| M 18x1,50   | 16,50   | D 104 x 29 x 14,00 x 11,20   |                  | 41,83         | 50,75   |  |
| M 18x2,50   | 15,50   | D 112 x 37 x 14,00 x 11,20   | 39,53            | 41,18         | 51,47   |  |
| M 20x1,50   | 18,50   | D 104 x 29 x 14,00 x 11,20   |                  | 47,66         | 54,59   |  |
| M 20x2,50   | 17,50   | D 112 x 37 x 14,00 x 11,20   | 44,18            | 46,01         | 54,27   |  |
| M 22x2,50   | 19,50   | D 118 x 38 x 16,00 x 12,50   | 51,08            | 53,22         | 66,53   |  |
| M 24x3,00   | 21,00   | D 130 x 45 x 18,00 x 14,00   | 57,72            | 60,12         | 75,14   |  |
| M 27x3,00   | 24,00   | D 135 x 45 x 20,00 x 16,00   | 71,07            | 74,04         | 92,54   |  |
| M 30x3,50   | 26,50   | D 138 x 48 x 20,00 x 16,00   | 105,60           | 110,00        | 129,70  |  |

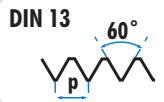
TARAUDS MACHINE DIN 352

M  
MF



HSS

HSSCo  
5%

DIN  
352

TOL  
6H

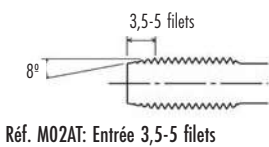
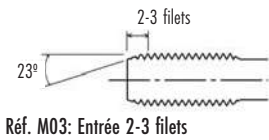

D  
QUEUE  
DÉGAGÉE

DIN  
352

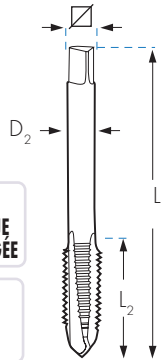

|           |       | L1 x L2 x D2 x $\square$<br>mm | M03      | M02AT                           | M03X               | M02DIN                    | M04DIN          |
|-----------|-------|--------------------------------|----------|---------------------------------|--------------------|---------------------------|-----------------|
|           |       |                                | HSS<br>€ | HAUTEUR<br>COMPLÈTE<br>HSS<br>€ | INOX<br>HSSCo<br>€ | ENTRÉE<br>GUN<br>HSS<br>€ | 35°<br>HSS<br>€ |
| M 3x0,50  | 2,50  | D 40 x 11 x 3,50 x 2,70        | 4,95     | 6,38                            | 9,52               | 8,09                      | 9,75            |
| M 4x0,70  | 3,30  | D 45 x 13 x 4,50 x 3,40        | 4,95     | 6,38                            | 9,52               | 8,09                      | 9,75            |
| M 5x0,80  | 4,20  | D 50 x 16 x 6,00 x 4,90        | 5,82     | 7,49                            | 9,65               | 8,09                      | 9,75            |
| M 6x1,00  | 5,00  | D 50 x 19 x 6,00 x 4,90        | 5,82     | 7,49                            | 9,63               | 8,09                      | 9,96            |
| M 7x1,00  | 6,00  | D 50 x 19 x 6,00 x 4,90        | 7,36     |                                 |                    |                           |                 |
| M 8x1,00  | 7,00  | D 56 x 18 x 6,00 x 4,90        | 11,44    |                                 |                    |                           |                 |
| M 8x1,25  | 6,75  | D 56 x 22 x 6,00 x 4,90        | 7,70     | 9,84                            | 11,06              | 10,80                     | 11,53           |
| M 9x1,25  | 7,75  | D 63 x 18 x 7,00 x 5,50        | 8,29     |                                 |                    |                           |                 |
| M 10x1,00 | 9,00  | D 63 x 18 x 7,00 x 5,50        | 12,26    |                                 |                    |                           |                 |
| M 10x1,25 | 8,80  | D 70 x 24 x 7,00 x 5,50        | 12,54    |                                 |                    |                           |                 |
| M 10x1,50 | 8,50  | D 70 x 24 x 7,00 x 5,50        | 8,36     | 10,67                           | 14,79              | 13,74                     | 14,86           |
| M 12x1,00 | 11,00 | D 70 x 20 x 9,00 x 7,00        | 20,08    |                                 |                    |                           |                 |
| M 12x1,25 | 10,75 | D 70 x 20 x 9,00 x 7,00        | 20,02    |                                 |                    |                           |                 |
| M 12x1,50 | 10,50 | D 70 x 20 x 9,00 x 7,00        | 18,47    |                                 |                    |                           |                 |
| M 12x1,75 | 10,20 | D 75 x 29 x 9,00 x 7,00        | 11,01    | 14,18                           | 19,30              | 16,66                     | 19,50           |
| M 14x1,00 | 13,00 | D 70 x 20 x 11,00 x 9,00       | 31,18    |                                 |                    |                           |                 |
| M 14x1,25 | 12,80 | D 70 x 20 x 11,00 x 9,00       | 23,26    |                                 |                    |                           |                 |
| M 14x1,50 | 12,50 | D 70 x 20 x 11,00 x 9,00       | 19,92    |                                 |                    |                           |                 |
| M 14x2,00 | 12,00 | D 80 x 30 x 11,00 x 9,00       | 14,83    | 19,11                           | 24,34              | 21,10                     | 25,56           |
| M 16x1,00 | 15,00 | D 70 x 20 x 12,00 x 9,00       | 34,01    |                                 |                    |                           |                 |
| M 16x1,25 | 14,75 | D 70 x 20 x 12,00 x 9,00       | 34,22    |                                 |                    |                           |                 |
| M 16x1,50 | 14,50 | D 70 x 20 x 12,00 x 9,00       | 24,51    |                                 |                    |                           |                 |
| M 16x2,00 | 14,00 | D 80 x 32 x 12,00 x 9,00       | 18,44    |                                 | 29,69              | 26,22                     | 29,65           |
| M 18x1,50 | 16,50 | D 80 x 22 x 14,00 x 11,00      | 27,78    |                                 |                    |                           |                 |
| M 18x2,50 | 15,50 | D 95 x 40 x 14,00 x 11,00      | 20,33    |                                 | 38,89              | 38,82                     | 49,10           |
| M 20x1,50 | 18,50 | D 80 x 22 x 16,00 x 12,00      | 33,85    |                                 |                    |                           |                 |
| M 20x2,50 | 17,50 | D 95 x 40 x 16,00 x 12,00      | 22,44    |                                 | 43,79              | 44,13                     | 51,76           |
| M 22x2,50 | 19,50 | D 100 x 40 x 18,00 x 14,50     | 31,38    |                                 |                    | 51,02                     | 63,44           |
| M 24x3,00 | 21,00 | D 110 x 50 x 18,00 x 14,50     | 40,40    |                                 |                    | 57,64                     | 71,67           |
| M 27x3,00 | 24,00 | D 110 x 50 x 20,00 x 16,00     | 56,35    |                                 |                    | 73,52                     | 91,12           |
| M 30x3,50 | 26,50 | D 125 x 50 x 22,00 x 18,00     | 70,56    |                                 |                    | 113,69                    | 122,33          |

TARAUDS MACHINE ET FILIÈRES SÉRIE *Plus* ET *Super Plus*

Tarauds et filières

Rose

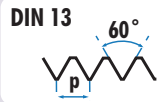

TOL  
6H

POUR GRANDES SÉRIES  
HSS PM: ACIER FRITTÉ

DIN  
22568

TOL  
6g

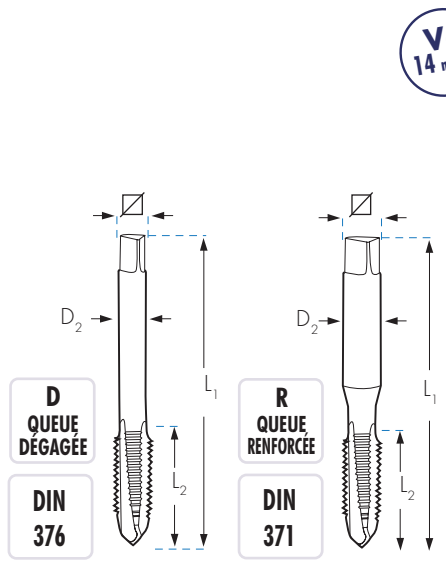

*Plus* *Plus TiN* *Plus LUBE* *Super Plus ALTiN*

| QUALITÉ              | M2RP             |    | M4RP                   |       | M2RT       |        | M4RT     |        | M2RHL      |        | M4RHL     |         | M2RSP      |      | M4RSP  |      | C5P       |   |
|----------------------|------------------|----|------------------------|-------|------------|--------|----------|--------|------------|--------|-----------|---------|------------|------|--------|------|-----------|---|
|                      | ★★               | ★★ | ★★★                    | ★★★   | ★★★★       | ★★★★   | ★★★      | ★★★    | ★★★★       | ★★★★   | ★★★★      | ★★★★    | ★★★★       | ★★★★ | ★★★★   | ★★★★ |           |   |
| MATÉRIEL             | HSS PM           |    | HSS PM                 |       | HSSCo 5%   |        | HSSCo 5% |        | HSS PM     |        | HSS PM    |         | HSS V3     |      | HSS V3 |      | HSS       |   |
| FINITION             | BRILLANT         |    | BRILLANT               |       | TiN        |        | TiN      |        | HARD LUBE  |        | HARD LUBE |         | ALTiN      |      | ALTiN  |      | BRILLANT  |   |
| HÉLICE               | ENTRÉE GUN       |    | 35°                    |       | ENTRÉE GUN |        | 35°      |        | ENTRÉE GUN |        | 35°       |         | ENTRÉE GUN |      | 41°    |      |           |   |
|                      | L1 x L2 x D2 x ∅ | mm | €                      | €     | €          | €      | €        | €      | €          | €      | €         | €       | €          | €    | €      | €    | ∅ x L3 mm | € |
| M 3x0,50             | 2,50             | R  | 56 x 11 x 3,5 x 2,7    | 13,06 | 16,13      | 18,93  | 21,32    | 21,78  | 23,57      | 40,58  | 42,47     | 25 x 9  | 24,49      |      |        |      |           |   |
| M 4x0,70             | 3,30             | R  | 63 x 13 x 4,5 x 3,4    | 13,33 | 16,13      | 19,98  | 22,25    | 22,10  | 23,90      | 40,58  | 42,47     | 25 x 9  | 24,49      |      |        |      |           |   |
| M 5x0,80             | 4,20             | R  | 70 x 16 x 6,0 x 4,9    | 13,33 | 15,47      | 19,98  | 21,81    | 22,10  | 23,90      | 42,86  | 44,03     | 25 x 9  | 24,49      |      |        |      |           |   |
| M 6x1,00             | 5,00             | R  | 80 x 17 x 6,0 x 4,9    | 14,66 | 16,96      | 22,15  | 23,99    | 24,28  | 25,30      | 42,86  | 44,03     | 25 x 9  | 24,49      |      |        |      |           |   |
| M 8x1,00             | 7,00             | D  | 90 x 20 x 6,0 x 4,9    | 20,92 | 24,83      | 28,94  | 32,21    | 34,16  | 38,03      |        |           | 25 x 9  | 32,88      |      |        |      |           |   |
| M 8x1,25             | 6,80             | R  | 90 x 20 x 8,0 x 6,2    | 17,18 | 19,71      | 25,66  | 28,16    | 28,64  | 32,19      | 54,41  | 57,98     | 25 x 9  | 25,58      |      |        |      |           |   |
| M 10x1,00            | 9,00             | D  | 90 x 16 x 7,0 x 5,5    | 23,33 | 29,27      | 33,80  | 38,81    | 39,89  | 47,15      |        |           | 30 x 10 | 40,20      |      |        |      |           |   |
| M 10x1,50            | 8,50             | R  | 100 x 22 x 10,0 x 8,0  | 20,20 | 22,96      | 30,65  | 33,42    | 35,53  | 40,06      | 64,85  | 69,16     | 30 x 10 | 36,51      |      |        |      |           |   |
| <b>QUEUE DÉGAGÉE</b> |                  |    | M2DP                   | M4DP  | M2DT       | M4DT   | M2DHL    | M4DHL  | M2DSP      | M4DSP  |           |         |            |      |        |      |           |   |
| M 12x1,50            | 10,50            | D  | 100 x 22 x 9,0 x 7,0   | 27,70 | 33,46      | 38,68  | 43,57    | 44,66  | 51,22      |        |           | 38 x 10 | 45,47      |      |        |      |           |   |
| M 12x1,75            | 10,20            | D  | 110 x 24 x 9,0 x 7,0   | 26,03 | 30,91      | 37,97  | 42,41    | 39,65  | 48,03      | 81,58  | 88,50     | 38 x 14 | 40,15      |      |        |      |           |   |
| M 14x1,50            | 12,50            | D  | 100 x 22 x 11,0 x 9,0  | 32,80 | 41,13      | 44,68  | 51,25    | 52,52  | 60,22      |        |           | 38 x 10 | 47,54      |      |        |      |           |   |
| M 14x2,00            | 12,00            | D  | 110 x 26 x 11,0 x 9,0  | 32,55 | 37,73      | 46,41  | 51,03    | 53,07  | 58,33      | 83,29  | 112,14    | 38 x 14 | 40,94      |      |        |      |           |   |
| M 16x1,50            | 14,50            | D  | 100 x 22 x 12,0 x 9,0  | 41,03 | 50,60      | 53,69  | 61,41    | 58,78  | 60,55      |        |           | 45 x 14 | 65,31      |      |        |      |           |   |
| M 16x2,00            | 14,00            | D  | 110 x 27 x 12,0 x 9,0  | 38,28 | 45,60      | 53,00  | 59,68    | 60,59  | 66,97      | 113,69 | 120,94    | 45 x 18 | 54,97      |      |        |      |           |   |
| M 18x2,50            | 15,50            | D  | 125 x 30 x 14,0 x 11,0 | 54,25 | 61,29      | 67,13  | 73,25    | 85,62  | 90,96      | 168,75 | 182,58    | 45 x 18 | 54,97      |      |        |      |           |   |
| M 20x2,50            | 17,50            | D  | 140 x 32 x 16,0 x 12,0 | 58,63 | 65,36      | 76,53  | 82,44    | 89,94  | 102,40     | 179,84 | 190,10    | 45 x 18 | 54,97      |      |        |      |           |   |
| M 22x2,50            | 19,50            | D  | 140 x 32 x 18,0 x 14,5 | 70,93 | 80,63      | 89,75  | 97,93    | 105,48 | 115,11     |        |           | 55 x 22 | 82,50      |      |        |      |           |   |
| M 24x3,00            | 21,00            | D  | 160 x 34 x 18,0 x 14,5 | 84,33 | 96,54      | 101,14 | 112,02   | 118,85 | 131,66     |        |           | 55 x 22 | 82,50      |      |        |      |           |   |

**TARAUDS MACHINE POUR TRAVAUX SPÉCIAUX**

**INOX**

**M**

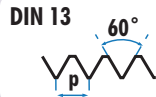

**TOL 6H**

HSS PM: ACIER FRITTÉ

**Vc 6 m/min**

**Vc 10 m/min**

**Vc 12 m/min**

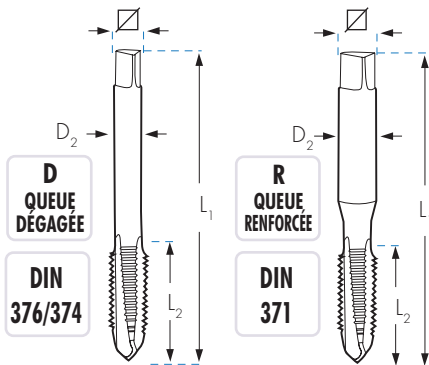

| QUALITÉ       | M2RX       |    | M4RX                          |        | M2RXT      |        | M4RXT          |        | M2RXHL     |      | M4RXHL         |      |
|---------------|------------|----|-------------------------------|--------|------------|--------|----------------|--------|------------|------|----------------|------|
|               | ★★         | ★★ | ★★                            | ★★     | ★★★        | ★★★    | ★★★            | ★★★    | ★★★★       | ★★★★ | ★★★★           | ★★★★ |
| MATÉRIEL      | HSS PM     |    | HSS PM                        |        | HSSCo 5%   |        | HSSCo 5%       |        | HSS PM     |      | HSS PM         |      |
| FINITION      | OX         |    | OX                            |        | TIN        |        | TIN            |        | HARD LUBE  |      | HARD LUBE      |      |
| HÉLICE        | ENTRÉE GUN |    | ENTRÉE GUN 35°                |        | ENTRÉE GUN |        | ENTRÉE GUN 35° |        | ENTRÉE GUN |      | ENTRÉE GUN 35° |      |
|               |            |    | L1 x L2 x D2 x $\nabla$<br>mm |        | €          | €      | €              | €      | €          | €    | €              | €    |
| M 3x0,50      | 2,50       | R  | 56 x 11 x 3,5 x 2,7           | 16,17  | 18,76      | 18,89  | 22,20          | 25,48  | 29,96      |      |                |      |
| M 4x0,70      | 3,30       | R  | 63 x 13 x 4,5 x 3,4           | 16,38  | 18,76      | 19,83  | 23,02          | 26,76  | 31,37      |      |                |      |
| M 5x0,80      | 4,20       | R  | 70 x 16 x 6,0 x 4,9           | 16,99  | 20,04      | 19,83  | 23,24          | 26,76  | 31,37      |      |                |      |
| M 6x1,00      | 5,00       | R  | 80 x 17 x 6,0 x 4,9           | 17,05  | 20,67      | 21,71  | 24,43          | 29,30  | 32,98      |      |                |      |
| M 8x1,00      | 7,00       | D  | 90 x 20 x 6,0 x 4,9           | 37,18  | 28,53      |        |                |        |            |      |                |      |
| M 8x1,25      | 6,80       | R  | 90 x 20 x 8,0 x 6,2           | 20,01  | 23,85      | 24,25  | 27,86          | 32,73  | 37,62      |      |                |      |
| M 10x1,00     | 9,00       | D  | 90 x 16 x 7,0 x 5,5           | 38,32  | 30,42      |        |                |        |            |      |                |      |
| M 10x1,50     | 8,50       | R  | 100 x 22 x 10,0 x 8,0         | 23,25  | 27,96      | 29,62  | 33,03          | 39,99  | 44,59      |      |                |      |
| QUEUE DÉGAGÉE |            |    |                               | M2DX   | M4DX       | M2DXT  | M4DXT          | M2DXHL | M4DXHL     |      |                |      |
| M 12x1,00     | 11,00      | D  | 100 x 22 x 9,0 x 7,0          | 46,07  | 37,40      |        |                |        |            |      |                |      |
| M 12x1,50     | 10,50      | D  | 100 x 22 x 9,0 x 7,0          | 43,45  | 35,35      |        |                |        |            |      |                |      |
| M 12x1,75     | 10,20      | D  | 110 x 24 x 9,0 x 7,0          | 29,50  | 42,02      | 38,05  | 47,60          | 53,60  | 62,77      |      |                |      |
| M 14x2,00     | 12,00      | D  | 110 x 26 x 11,0 x 9,0         | 38,69  | 58,52      | 50,55  | 59,55          | 71,23  | 78,89      |      |                |      |
| M 16x2,00     | 14,00      | D  | 110 x 27 x 12,0 x 9,0         | 42,46  | 67,55      | 55,96  | 76,25          | 79,32  | 95,42      |      |                |      |
| M 18x2,50     | 15,50      | D  | 125 x 30 x 14,0 x 11,0        | 60,82  | 96,10      | 86,05  | 106,72         | 127,28 | 135,74     |      |                |      |
| M 20x2,50     | 17,50      | D  | 140 x 32 x 16,0 x 12,0        | 62,72  | 101,47     | 99,25  | 109,79         | 135,31 | 143,33     |      |                |      |
| M 22x2,50     | 19,50      | D  | 140 x 32 x 18,0 x 14,5        | 96,93  | 126,44     | 135,15 | 160,96         |        |            |      |                |      |
| M 24x3,00     | 21,00      | D  | 160 x 34 x 18,0 x 14,5        | 101,91 | 132,94     | 137,77 | 164,63         |        |            |      |                |      |
| M 27x3,00     | 24,00      | D  | 160 x 36 x 20,0 x 16,0        | 133,50 | 174,13     |        |                |        |            |      |                |      |
| M 30x3,50     | 26,50      | D  | 180 x 40 x 22,0 x 18,0        | 170,72 | 222,68     |        |                |        |            |      |                |      |



- Lubrifiant: **CUT MAGIC XTHICK**
- L'utilisation de l'huile de coupe CUT MAGIC XTHICK est recommandée pour optimiser le processus de taraudage en Inox, Duplex, Inconel, Titane...

Réf. ACXT00250

**TARAUDS *Super Plus* POUR LE TARAUDAGE D'ALLIAGES RÉFRACTAIRES**

M

DIN 13

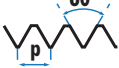
TOL  
6HINOX  
DUPLEX

Ni

INC

Ti

SPÉCIFIQUEMENT RECOMMANDÉS  
EN APPLICATIONS AÉRONAUTIQUESVc  
15  
m/minINOX  
DUPLEXVc  
6  
m/minNICKEL  
INCONELVc  
6  
m/min

TITANE

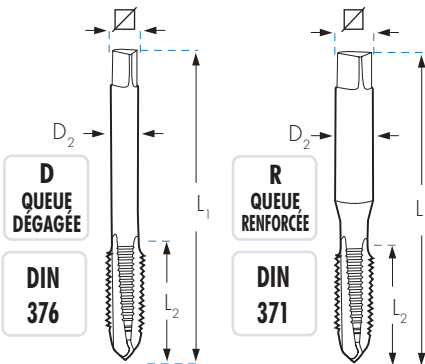

|                      |       |  | M2RDU         | M4RDU     | M2RNI         | M3RNI     | M2RTIT        | M3RTIT    |
|----------------------|-------|--|---------------|-----------|---------------|-----------|---------------|-----------|
| QUALITÉ              |       |  | ★★★★          | ★★★★      | ★★★★          | ★★★★      | ★★★★          | ★★★★      |
| MATÉRIEL             |       |  | HSS<br>V3     | HSS<br>V3 | HSS<br>PM     | HSS<br>PM | HSS<br>PM     | HSS<br>PM |
| FINITION             |       |  | TiCN          | TiCN      | BRILLANT      | BRILLANT  | OX            | OX        |
| HÉLICE               |       |  | ENTRÉE<br>GUN | 41°       | ENTRÉE<br>GUN | 15°       | ENTRÉE<br>GUN | 15°       |
|                      |       | L <sub>1</sub> x L <sub>2</sub> x D <sub>2</sub> x | €             | €         | €             | €         | €             | €         |
| M 3x0,50             | 2,50  | R 56 x 11 x 3,5 x 2,7                              | 41,15         | 42,14     | 76,46         | 78,12     | 56,77         | 62,65     |
| M 4x0,70             | 3,30  | R 63 x 13 x 4,5 x 3,4                              | 41,15         | 42,41     | 78,12         | 80,23     | 58,52         | 62,65     |
| M 5x0,80             | 4,20  | R 70 x 16 x 6,0 x 4,9                              | 42,52         | 43,37     | 80,88         | 82,78     | 60,00         | 66,73     |
| M 6x1,00             | 5,00  | R 80 x 17 x 6,0 x 4,9                              | 43,70         | 44,63     | 81,51         | 83,82     | 60,00         | 67,67     |
| M 8x1,25             | 6,80  | R 90 x 20 x 8,0 x 6,2                              | 61,04         | 63,64     | 92,12         | 94,57     | 69,33         | 78,12     |
| M 10x1,50            | 8,50  | R 100 x 22 x 10,0 x 8,0                            | 79,11         | 81,17     | 109,46        | 112,80    | 85,88         | 94,14     |
| <b>QUEUE DÉGAGÉE</b> |       |  | M2DDU         | M4DDU     | M2DNI         | M3DNI     | M2DTIT        | M3DTIT    |
| M 12x1,75            | 10,20 | D 110 x 24 x 9,0 x 7,0                             | 106,94        | 115,48    | 140,78        | 155,66    | 107,79        | 116,96    |
| M 14x2,00            | 12,00 | D 110 x 26 x 11,0 x 9,0                            |               |           |               |           |               |           |
| M 16x2,00            | 14,00 | D 110 x 27 x 12,0 x 9,0                            | 157,27        | 168,18    |               |           |               |           |
| M 18x2,50            | 15,50 | D 125 x 30 x 14,0 x 11,0                           |               |           |               |           |               |           |
| M 20x2,50            | 17,50 | D 140 x 32 x 16,0 x 12,0                           | 232,89        | 251,56    |               |           |               |           |
| M 22x2,50            | 19,50 | D 140 x 32 x 18,0 x 14,5                           |               |           |               |           |               |           |
| M 24x3,00            | 21,00 | D 160 x 34 x 18,0 x 14,5                           | 315,45        | 320,84    |               |           |               |           |
| M 27x3,00            | 24,00 | D 160 x 36 x 20,0 x 16,0                           | 405,25        | 424,79    |               |           |               |           |
| M 30x3,50            | 26,50 | D 180 x 40 x 22,0 x 18,0                           | 478,61        | 500,81    |               |           |               |           |



TARAUDS POUR MATIÈRES SUPER TENDRES < À 450N/mm<sup>2</sup>

DIN 13 60°  
HSSCo 5%  
OX  
TOL 6H

APPLICATIONS

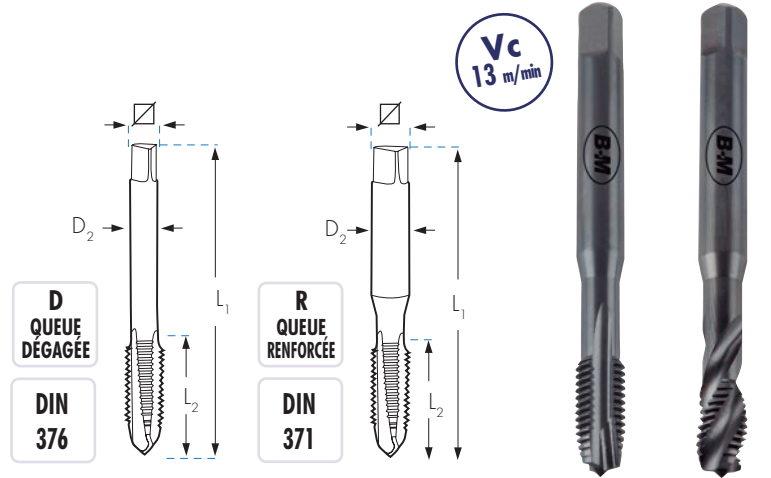

450 N/mm<sup>2</sup> ST52 AI

Géométrie de coupe spécifique pour matières tendres, ne générant pas d'excès dimensionnel et s'adaptant parfaitement à ce type de matière dans laquelle les tarauds classiques peuvent provoquer de l'imprécision à l'heure de générer le taraudage.

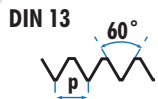
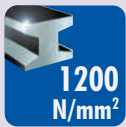
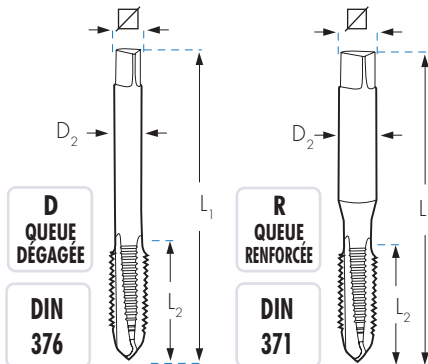

| D                    | L1    | L2 | D2                     | M2RSS        |        | M4RSS        |   |
|----------------------|-------|----|------------------------|--------------|--------|--------------|---|
|                      |       |    |                        | ENTRÉE GUN   | €      | ENTRÉE GUN   | € |
| M 3 x 0,50           | 2,50  | R  | 56 x 11 x 3,5 x 2,7    | 13,58        | 17,88  |              |   |
| M 4 x 0,70           | 3,30  | R  | 63 x 13 x 4,5 x 3,4    | 14,34        | 17,89  |              |   |
| M 5 x 0,80           | 4,20  | R  | 70 x 16 x 6,0 x 4,9    | 14,43        | 17,15  |              |   |
| M 6 x 1,00           | 5,00  | R  | 80 x 17 x 6,0 x 4,9    | 15,29        | 18,82  |              |   |
| M 8 x 1,25           | 6,80  | R  | 90 x 20 x 8,0 x 6,2    | 17,68        | 21,79  |              |   |
| M 10 x 1,50          | 8,50  | R  | 100 x 22 x 10,0 x 8,0  | 21,78        | 25,81  |              |   |
| <b>QUEUE DÉGAGÉE</b> |       |    |                        | <b>M2DSS</b> |        | <b>M4DSS</b> |   |
| M 12 x 1,75          | 10,20 | D  | 110 x 24 x 9,0 x 7,0   | 24,70        | 29,92  |              |   |
| M 14 x 2,00          | 12,00 | D  | 110 x 26 x 11,0 x 9,0  | 35,27        | 41,49  |              |   |
| M 16 x 2,00          | 14,00 | D  | 110 x 27 x 12,0 x 9,0  | 39,34        | 47,89  |              |   |
| M 18 x 2,50          | 15,50 | D  | 125 x 30 x 14,0 x 11,0 | 56,07        | 67,48  |              |   |
| M 20 x 2,50          | 17,50 | D  | 140 x 32 x 16,0 x 12,0 | 65,64        | 72,03  |              |   |
| M 22 x 2,50          | 19,50 | D  | 140 x 32 x 18,0 x 14,5 | 78,76        | 87,78  |              |   |
| M 24 x 3,00          | 21,00 | D  | 160 x 34 x 18,0 x 14,5 | 92,80        | 106,70 |              |   |
| M 27 x 3,00          | 24,00 | D  | 160 x 36 x 20,0 x 16,0 | 117,36       | 131,29 |              |   |
| M 30 x 3,50          | 26,50 | D  | 180 x 40 x 22,0 x 18,0 | 150,80       | 168,26 |              |   |

**TARAUDS MACHINE HSS-V3 POUR TRAVAUX SPÉCIAUX**

**HSS  
V3**
**TOL  
6H**
**MATÉRIAUX  
DURS**

**Vc  
7 m/min**
**Vc  
9 m/min**

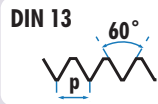
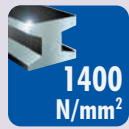
|   |   | M2RMD         | M4RMD     | M2RMDTX       | M4RMDTX   |
|---|---|---------------|-----------|---------------|-----------|
| QUALITÉ   |   | ★★★           | ★★★       | ★★★★          | ★★★★      |
| MATÉRIEL  |   | HSS<br>V3     | HSS<br>V3 | HSS<br>V3     | HSS<br>V3 |
| FINITION  |   | OX            | OX        | TINALOX       | TINALOX   |
| HÉLICE  |   | ENTRÉE<br>GUN | 35°       | ENTRÉE<br>GUN | 35°       |
|  |  |               |           |               |           |
|   | $L_1 \times L_2 \times D_2 \times \square$<br>mm                                    | €             | €         | €             | €         |
| M 3x0,50  | 2,50 R 56 x 11 x 3,5 x 2,7  | 16,73         | 19,23     | 23,88         | 28,06     |
| M 4x0,70  | 3,30 R 63 x 13 x 4,5 x 3,4  | 17,38         | 19,23     | 25,06         | 29,38     |
| M 5x0,80  | 4,20 R 70 x 16 x 6,0 x 4,9  | 17,38         | 19,28     | 25,06         | 29,38     |
| M 6x1,00  | 5,00 R 80 x 17 x 6,0 x 4,9  | 19,06         | 21,01     | 27,45         | 30,88     |
| M 8x1,25  | 6,80 R 90 x 20 x 8,0 x 6,2  | 21,49         | 23,51     | 30,65         | 35,23     |
| M 10x1,50   | 8,50 R 100 x 22 x 10,0 x 8,0  | 24,75         | 27,33     | 38,77         | 43,26     |
| <b>QUEUE DÉGAGÉE</b>  |   | M2DMD         | M4DMD     | M2DMDTX       | M4DMDTX   |
| M 12x1,75   | 10,20 D 110 x 24 x 9,0 x 7,0  | 35,27         | 38,57     | 51,65         | 60,46     |
| M 14x2,00   | 12,00 D 110 x 26 x 11,0 x 9,0   | 43,86         | 50,97     | 73,51         | 80,68     |
| M 16x2,00   | 14,00 D 110 x 27 x 12,0 x 9,0   | 51,77         | 61,65     | 81,88         | 97,60     |
| M 18x2,50   | 15,50 D 125 x 30 x 14,0 x 11,0  | 73,15         | 87,72     | 120,35        | 136,32    |
| M 20x2,50   | 17,50 D 140 x 32 x 16,0 x 12,0  | 79,07         | 92,61     | 130,08        | 143,89    |

TARAUDS MACHINE POUR ACIERS TREMPÉS (HARDOX 450/500)



TOL  
6H

HSSE

HSS  
PM

CARBURE

MATÉRIAUX  
TRÈS  
DURS

48  
HRc

48-62  
HRc

Vc  
5 m/min

CARBURE

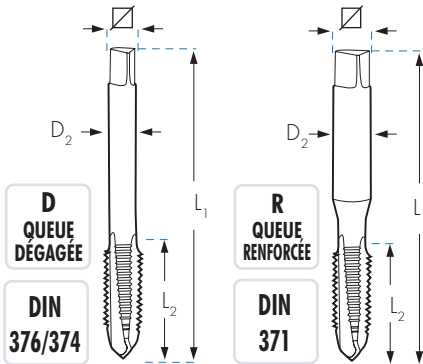

| MATÉRIEL             | M2RC       |                          | M3RC   |        | M2HRC      |         | M4HRC   |          | M1RCM         |               | M1RHMC        |         |
|----------------------|------------|--------------------------|--------|--------|------------|---------|---------|----------|---------------|---------------|---------------|---------|
|                      | HSSE       | HSSE                     | HSS PM | HSS PM | TINALOX    | TINALOX | TiCN    | TiCN     | ENTRÉE DROITE | ENTRÉE DROITE | CARBURE       | CARBURE |
| FINITION             | TiAIN      |                          | TiAIN  |        | TINALOX    |         | TINALOX |          | TiCN          |               | TiCN          |         |
| FORME                | FOR ENTRÉE |                          | 15°    |        | FOR ENTRÉE |         | 35°     |          | ENTRÉE DROITE |               | ENTRÉE DROITE |         |
|                      | €          | €                        | €      | €      | €          | €       | €       | €        | €             | €             | €             | €       |
| M 2 x 0,40           | 1,60       | R 40 x 9 x 2,5 x 2,1     |        |        | 34,07      | 37,25   | 1,70    |          | 1,70          |               |               |         |
| M 3 x 0,50           | 2,50       | R 56 x 11 x 3,5 x 2,7    | 28,11  | 29,91  | 31,09      | 34,82   | 2,60    | 44,61    | 2,60          | 116,58        |               |         |
| M 4 x 0,70           | 3,30       | R 63 x 13 x 4,5 x 3,4    | 28,17  | 31,85  | 32,29      | 36,16   | 3,40    | 39,24    | 3,40          | 116,58        |               |         |
| M 5 x 0,80           | 4,20       | R 70 x 16 x 6,0 x 4,9    | 28,43  | 31,12  | 32,59      | 36,51   | 4,30    | 43,85    | 4,30          | 116,58        |               |         |
| M 6 x 1,00           | 5,00       | R 80 x 17 x 6,0 x 4,9    | 30,74  | 34,46  | 34,00      | 38,07   | 5,10    | 56,14    | 5,10          | 145,72        |               |         |
| M 8 x 1,25           | 6,80       | R 90 x 20 x 8,0 x 6,2    | 35,51  | 40,52  | 42,26      | 47,34   | 6,90    | 62,27    | 6,90          | 164,01        |               |         |
| M 10 x 1,50          | 8,50       | R 100 x 22 x 10,0 x 8,0  | 42,51  | 50,20  | 50,58      | 53,10   | 8,60    | 80,73    | 8,60          | 251,65        |               |         |
| <b>QUEUE DÉGAGÉE</b> |            |                          | M2DC   | M3DC   | M2HDC      | M4HDC   | M1RCM   |          | M1DHMC        |               |               |         |
| M 12 x 1,75          | 10,20      | D 110 x 24 x 9,0 x 7,0   | 63,56  | 75,45  | 77,21      | 84,16   | 10,40   | 106,80 * | 10,40         | 394,13        |               |         |
| M 14 x 2,00          | 12,00      | D 110 x 26 x 11,0 x 9,0  | 85,82  | 100,38 | 91,56      | 102,98  | 12,10   | 135,03 * | 12,10         | 485,93        |               |         |
| M 16 x 2,00          | 14,00      | D 110 x 27 x 12,0 x 9,0  | 96,84  | 115,30 | 101,80     | 118,05  | 14,10   | 144,44 * | 16,10         | 634,52        |               |         |
| M 18 x 2,50          | 15,50      | D 125 x 30 x 14,0 x 11,0 | 122,62 | 133,52 | 126,02     | 137,36  |         |          | 15,75         | 775,19        |               |         |
| M 20 x 2,50          | 17,50      | D 140 x 32 x 16,0 x 12,0 | 148,50 | 154,56 | 148,82     | 162,22  |         |          | 17,75         | 1.226,22      |               |         |
| M 22 x 2,50          | 19,50      | D 140 x 32 x 18,0 x 14,5 | 210,36 | 219,36 |            |         |         |          |               |               |               |         |
| M 24 x 3,00          | 21,00      | D 160 x 34 x 18,0 x 14,5 | 215,36 | 225,36 | 224,73     | 244,95  |         |          |               |               |               |         |
| M 27 x 3,00          | 24,00      | D 160 x 36 x 20,0 x 16,0 | 235,36 | 242,36 |            |         |         |          |               |               |               |         |
| M 30 x 3,50          | 26,50      | D 180 x 40 x 22,0 x 18,0 | 241,25 | 255,36 |            |         |         |          |               |               |               |         |

\* Queue Renforcée: M12 - Ø 12 x 9  
M14 - Ø 14 x 11  
M16 - Ø 16 x 12



- Lubrifiant: **CUT MAGIC XTHICK**
- Nous recommandons de tarauder la pièce sur la même installation que pour le perçage et dans la même position, pour garantir la coaxialité entre taraud et avant-trou.

Réf. ACXT00250

| HRc    | Vc (m/min) |
|--------|------------|
| 48 Hrc | 8 m/min    |
| 56 Hrc | 6 m/min    |
| 62 Hrc | 3 m/min    |

**TARAUDS MACHINE TOUT TERRAIN**
**TOUT  
TERRAIN**

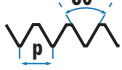

DIN 13

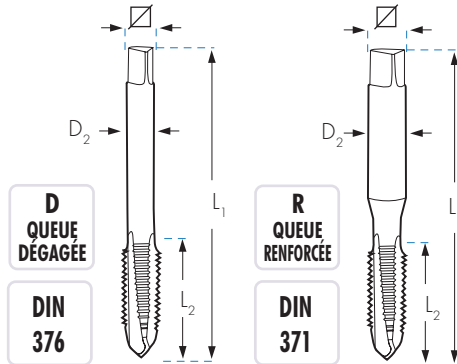

60°

**HSSCo  
5%**
**TiN**
**TOL  
6H**
**APPLICATIONS**

**1200  
N/mm<sup>2</sup>**
**Al**
**FORTE**
**Ti**
**INOX**
**Vc  
13  
m/min**

**D  
QUEUE  
DÉGAGÉE**
**DIN  
376**
**R  
QUEUE  
RENFORCÉE**
**DIN  
371**

|  |  | $L_1 \times L_2 \times D_2 \times \square$<br>mm | M2RD               | M4RD  |
|---|--|--|--------------------|---|
|   |  |  | ENTRÉE<br>GUN<br>€ | <br>€ |
| M 3 x 0,50  | 2,50   | R 56 x 11 x 3,5 x 2,7                            | 19,98              | 24,42   |
| M 4 x 0,70  | 3,30   | R 63 x 13 x 4,5 x 3,4                            | 21,18              | 24,42   |
| M 5 x 0,80  | 4,20   | R 70 x 16 x 6,0 x 4,9                            | 24,53              | 27,90   |
| M 6 x 1,00  | 5,00   | R 80 x 17 x 6,0 x 4,9                            | 25,38              | 28,96   |
| M 8 x 1,25  | 6,80   | R 90 x 20 x 8,0 x 6,2                            | 29,74              | 33,04   |
| M 10 x 1,50   | 8,50   | R 100 x 22 x 10,0 x 8,0                          | 34,31              | 39,14   |
| <b>QUEUE DÉGAGÉE</b>  |  |  | M2DD               | M4DD  |
| M 12 x 1,75   | 10,20  | D 110 x 24 x 9,0 x 7,0                           | 43,24              | 51,46   |
| M 14 x 2,00   | 12,00  | D 110 x 26 x 11,0 x 9,0                          | 56,47              | 62,04   |
| M 16 x 2,00   | 14,00  | D 110 x 27 x 12,0 x 9,0                          | 63,27              | 68,47   |
| M 18 x 2,50   | 15,50  | D 125 x 30 x 14,0 x 11,0                         | 86,33              | 101,39  |
| M 20 x 2,50   | 17,50  | D 140 x 32 x 16,0 x 12,0                         | 100,69             | 104,48  |

TARAUDS MACHINE POUR TRAVAUX SPÉCIAUX HSSCo/CARBURE

Al
FONTE
LAITON
DIN 13 60°
HSSCo 5%
CARBURE
TOL 6H



**D**  
QUEUE DÉGAGÉE  
DIN 376



**R**  
QUEUE RENFORCÉE  
DIN 371

Vc 18 m/min



Vc 11 m/min



Vc 21 m/min





Vc 16 m/min



Vc 19 m/min





|   |   | M5R  | M6R        | MTRFM         | MHMTR         | M1RL          | M1RLCRN       |       |
|---|---|--|------------|---------------|---------------|---------------|---------------|-------|
| APPLICATION   |   | Al   | Al         | FONTE         | FONTE         | LAITON        | LAITON        |       |
| MATÉRIEL  |   | HSSCo 5%   | HSSCo 5%   | HSSCo 5%      | CARBURE       | HSSCo 5%      | HSSCo 5%      |       |
| FINITION  |   | BRILLANT   | BRILLANT   | OX            | BRILLANT      | BRILLANT      | CrN           |       |
| FORME   |   | FILET ALTERNÉ  | 2 GOUJURES | ENTRÉE DROITE | ENTRÉE DROITE | ENTRÉE DROITE | ENTRÉE DROITE |       |
|  |  | L <sub>1</sub> x L <sub>2</sub> x D <sub>2</sub> x  |            | €             | €             | €             | €             |       |
| M 3x0,50  | 2,50  | R 56 x 11 x 3,5 x 2,7  | 15,76      | 18,20         | 13,53         | 75,46         | 16,06         | 18,23 |
| M 4x0,70  | 3,30  | R 63 x 13 x 4,5 x 3,4  | 15,88      | 18,20         | 14,00         | 75,46         | 17,06         | 20,10 |
| M 5x0,80  | 4,20  | R 70 x 16 x 6,0 x 4,9  | 16,42      | 18,57         | 14,00         | 75,46         | 17,06         | 20,17 |
| M 6x1,00  | 5,00  | R 80 x 17 x 6,0 x 4,9  | 16,54      | 20,07         | 15,89         | 86,06         | 18,69         | 22,04 |
| M 8x1,25  | 6,80  | R 90 x 20 x 8,0 x 6,2  | 19,89      | 24,06         | 17,80         | 96,12         | 21,30         | 26,80 |
| M 10x1,50   | 8,50  | R 100 x 22 x 10,0 x 8,0  | 23,64      | 28,46         | 20,34         | 120,43        | 25,63         | 32,61 |
| <b>QUEUE DÉGAGÉE</b>  |   | M5D  | M6D        | M1DFM         | MHM1D         | M1DL          | M1DLCRN       |       |
| M 12x1,75   | 10,20   | D 110 x 24 x 9,0 x 7,0   | 30,26      | 36,80         | 26,07         | 171,22        | 30,46         | 40,13 |
| M 14x2,00   | 12,00   | D 110 x 26 x 11,0 x 9,0  | 39,10      | 46,59         | 42,85         | 266,76        | 37,39         | 48,91 |
| M 16x2,00   | 14,00   | D 110 x 27 x 12,0 x 9,0  | 43,44      | 60,98         | 50,45         | 317,37        | 43,02         | 54,69 |
| M 18x2,50   | 15,50   | D 125 x 30 x 14,0 x 11,0   |            |               | 70,55         | 389,03        | 56,42         | 69,27 |
| M 20x2,50   | 17,50   | D 140 x 32 x 16,0 x 12,0   |            |               | 70,82         | 471,09        | 63,33         | 77,12 |



- Lubrifiant: **CUT MAGIC ALUMINIUM**
- L'utilisation de l'huile de coupe CUT MAGIC ALUMINIUM est recommandée pour optimiser le processus de taraudage en Aluminium et ses fontes

Réf. ACAL00250

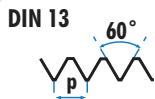
**TARAUDS MACHINE À REFOULER**

**HSSCo**  
**5%**
**HSSCo**  
**8%**
**TOL**  
**6HX**
**APPLICATIONS**

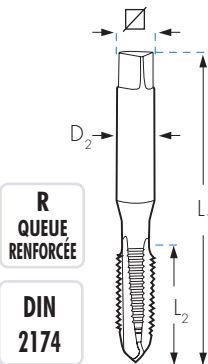
**Al**
 **Fonte**

**INOX**
*Plus*

**R**  
**QUEUE**  
**RENFORCÉE**
**DIN**  
**2174**

| APPLICATION | MATÉRIEL                  | FINITION   | FORME | M07R                      | M07RT      | M07RCR                    | M07RCCR                   | M09RCCR                   | M07RXTCR                  |
|-------------|---------------------------|--|-------|---------------------------|------------|---------------------------|---------------------------|---------------------------|---------------------------|
|             |                           |  |       |                           |            |                           |                           |                           |                           |
|             | <b>HSSCo</b><br><b>5%</b> | <b>OX</b>  |       | <b>HSSCo</b><br><b>5%</b> | <b>TiN</b> | <b>HSSCo</b><br><b>5%</b> | <b>HSSCo</b><br><b>5%</b> | <b>HSSCo</b><br><b>8%</b> | <b>HSSCo</b><br><b>5%</b> |
|             |                           |  |       | <b>OX</b>                 | <b>TiN</b> | <b>OX</b>                 | <b>TiCN</b>               | <b>TiCN</b>               | <b>TiN</b>                |
|             |                           |  |       |                           |            |                           |                           |                           |                           |
|             |                           | $L_1 \times L_2 \times D_2 \times \square$<br>mm | €     | €                         | €          | €                         | €                         | €                         | €                         |
| M 3x0,50    | 2,75                      | R 56 x 11 x 3,5 x 2,7                            | 29,82 | 33,61                     | 32,82      | 47,16                     | 107,00                    | 79,80                     |                           |
| M 3,5x0,60  | 3,20                      | R 56 x 11 x 3,5 x 2,7                            | 31,34 | 35,70                     | 33,91      | 49,91                     |                           |                           |                           |
| M 4x0,70    | 3,65                      | R 63 x 13 x 4,5 x 3,4                            | 29,82 | 35,06                     | 32,82      | 49,18                     | 108,36                    | 79,80                     |                           |
| M 5x0,80    | 4,60                      | R 70 x 16 x 6,0 x 4,9                            | 29,82 | 35,06                     | 32,82      | 49,18                     | 109,81                    | 86,12                     |                           |
| M 6x1,00    | 5,50                      | R 80 x 17 x 6,0 x 4,9                            | 32,21 | 37,07                     | 35,40      | 51,97                     | 111,54                    | 86,12                     |                           |
| M 8x1,25    | 7,40                      | R 90 x 20 x 8,0 x 6,2                            | 37,52 | 48,91                     | 41,29      | 68,62                     | 123,73                    | 103,07                    |                           |
| M 10x1,50   | 9,30                      | R 100 x 22 x 10,0 x 8,0                          | 41,74 | 54,83                     | 45,92      | 75,52                     | 147,73                    | 125,83                    |                           |

| QUEUE DÉGAGÉE |       |                          | M07D   | M07DT  | M07DCR | M07DCCR | M09DCCR | M07DXTCR |
|---------------|-------|--------------------------|--------|--------|--------|---------|---------|----------|
| M 12x1,75     | 11,20 | D 110 x 24 x 9,0 x 7,0   | 49,17  | 69,06  | 54,11  | 96,34   | 174,88  | 163,86   |
| M 14x2,00     | 13,05 | D 110 x 26 x 11,0 x 9,0  | 88,68  | 113,26 | 95,66  | 154,44  | 217,63  | 235,72   |
| M 16x2,00     | 15,05 | D 110 x 27 x 12,0 x 9,0  | 104,10 | 127,56 | 112,29 | 181,23  | 299,33  | 239,81   |
| M 18x2,50     | 16,80 | D 125 x 30 x 14,0 x 11,0 | 119,47 | 146,88 | 128,84 | 193,18  | 354,68  |          |
| M 20x2,50     | 18,80 | D 140 x 32 x 16,0 x 12,0 | 157,40 | 222,35 | 169,79 | 316,78  | 392,66  |          |

TARAUDS MACHINE HSSCo TOLÉRANCES SPÉCIALES ET SURCÔTÉS



|                          |       | M2R4H              | M4R4H          | M2R6G      | M4R6G          | M2R7G      | M4R7G          | M2R+0,1       | M4R+0,1        | M2R+0,2       | M4R+0,2        |        |
|--------------------------|-------|--------------------|----------------|------------|----------------|------------|----------------|---------------|----------------|---------------|----------------|--------|
| TOLÉRANCE                |       | TOL 4H             | TOL 4H         | TOL 6G     | TOL 6G         | TOL 7G     | TOL 7G         | TOL 6H (+0,1) | TOL 6H (+0,1)  | TOL 6H (+0,2) | TOL 6H (+0,2)  |        |
| MATÉRIEL                 |       | HSSCo 5%           | HSSCo 5%       | HSSCo 5%   | HSSCo 5%       | HSSCo 5%   | HSSCo 5%       | HSSCo 5%      | HSSCo 5%       | HSSCo 5%      | HSSCo 5%       |        |
| FINITION                 |       | BRILLANT           | BRILLANT       | BRILLANT   | BRILLANT       | BRILLANT   | BRILLANT       | BRILLANT      | BRILLANT       | BRILLANT      | BRILLANT       |        |
| FORME                    |       | ENTRÉE GUN         | ENTRÉE GUN 35° | ENTRÉE GUN | ENTRÉE GUN 35° | ENTRÉE GUN | ENTRÉE GUN 35° | ENTRÉE GUN    | ENTRÉE GUN 35° | ENTRÉE GUN    | ENTRÉE GUN 35° |        |
| L1 x L2 x D2 x $\square$ |       | €                  | €              | €          | €              | €          | €              | €             | €              | €             | €              |        |
| M 3x0,50                 | 2,50  | R 56x11x 3,5x 2,7  | 18,70          | 23,14      | 13,19          | 16,10      | 18,70          | 23,14         | 16,62          | 24,79         | 24,17          | 29,92  |
| M 4x0,70                 | 3,30  | R 63x13x 4,5x 3,4  | 19,12          | 23,14      | 13,19          | 16,10      | 19,12          | 23,14         | 15,68          | 24,79         | 24,73          | 26,40  |
| M 5x0,80                 | 4,20  | R 70x16x 6,0x 4,9  | 19,12          | 22,16      | 13,89          | 16,81      | 19,12          | 22,16         | 15,68          | 23,77         | 24,73          | 28,65  |
| M 6x1,00                 | 5,00  | R 80x17x 6,0x 4,9  | 21,03          | 24,33      | 13,84          | 16,92      | 21,03          | 24,33         | 15,73          | 26,05         | 27,17          | 31,44  |
| M 8x1,00                 | 7,00  | D 90x20x 6,0x 4,9  |                |            | 32,67          | 36,14      |                |               |                |               |                |        |
| M 8x1,25                 | 6,75  | R 90x20x 8,0x 6,2  | 23,55          | 27,76      | 17,60          | 20,85      | 23,55          | 27,76         | 19,28          | 29,75         | 26,86          | 35,90  |
| M 10x1,00                | 9,00  | D 90x16x 7,0x 5,5  |                |            | 38,57          | 44,90      |                |               |                |               |                |        |
| M 10x1,50                | 8,50  | R 100x22x10,0x 8,0 | 28,96          | 32,94      | 20,85          | 23,86      | 28,96          | 32,94         | 23,73          | 35,28         | 33,06          | 37,57  |
| <b>QUEUE DÉGAGÉE</b>     |       | M2D4H              | M4D4H          | M2D6G      | M4D6G          | M2D7G      | M4D7G          | M2D+0,1       | M4D+0,1        | M2D+0,2       | M4D+0,2        |        |
| M 12x1,50                | 10,50 | D 100x22x 9,0x 7,0 |                | 68,24      | 80,92          |            |                |               |                |               |                |        |
| M 12x1,75                | 10,20 | D 110x24x 9,0x 7,0 | 37,33          | 44,33      | 24,37          | 26,42      | 37,33          | 44,33         | 29,27          | 47,48         | 42,56          | 59,59  |
| M 14x2,00                | 12,00 | D 110x26x11,0x 9,0 |                |            | 35,51          | 38,02      |                |               | 63,41          | 75,60         | 78,67          | 91,20  |
| M 16x2,00                | 14,00 | D 110x27x12,0x 9,0 |                |            | 39,65          | 40,33      |                |               | 74,58          | 91,35         | 81,69          | 97,27  |
| M 18x2,50                | 15,50 | D 125x30x14,0x11,0 |                |            | 55,16          | 59,16      |                |               | 108,66         | 123,03        | 131,10         | 138,04 |
| M 20x2,50                | 17,50 | D 140x32x16,0x12,0 |                |            | 67,95          | 77,94      |                |               | 117,43         | 130,92        | 141,66         | 148,74 |

4H.- Pour filetages très précis. Ajustage supérieur.

6G.- Pour filetages avec revêtement. Epaisseurs entre 20-40 μ



7G.- Pour filetages avec revêtement. Epaisseurs entre 40-50 μ

6H (+0,1).- Pour obtenir des filetages surcôtés ou pour compenser les déformations du traitement thermique.

6H (+0,2).- Pour obtenir des filetages surcôtés ou pour compenser les déformations du traitement thermique.

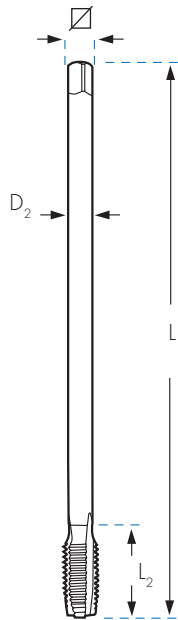
**TARAUDS MACHINE EXTRA-LONGS HSSCo**
**ENTRÉE  
GUN**

**HSSCo  
5%**
**BRILLANT**
**TOL  
6H**
**R  
QUEUE  
RENFORCÉE**
**DIN  
371**
**D  
QUEUE  
DÉGAGÉE**
**DIN  
376**





|   |   |  |  | M2L                |
|---|---|--|--|--------------------|
|  |  |  | $L_1 \times L_2 \times D_2 \times \square$<br>mm | ENTRÉE<br>GUN<br>€ |
| M   | 3x0,50  | 2,50   | R 100 x 10 x 3,5 x 2,7                           | 16,97              |
| M   | 4x0,70  | 3,30   | R 120 x 12 x 4,5 x 3,4                           | 17,35              |
| M   | 5x0,80  | 4,20   | R 140 x 14 x 6,0 x 4,9                           | 20,41              |
| M   | 6x1,00  | 5,00   | R 160 x 16 x 6,0 x 4,9                           | 20,46              |
| M   | 7x1,00  | 6,00   | R 160 x 17 x 7,0 x 5,5                           | 24,80              |
| M   | 8x1,25  | 6,80   | R 180 x 18 x 8,0 x 6,2                           | 24,92              |

**QUEUE DÉGAGÉE**

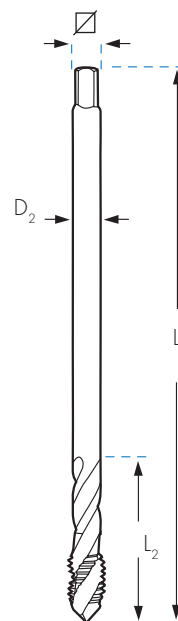
|   |         |       |                          | M2L-D  |
|---|---------|-------|--------------------------|--------|
| M |         | D     |                          | €      |
| M | 6x1,00  | 5,00  | D 160 x 16 x 4,5 x 3,4   | 22,68  |
| M | 8x1,25  | 6,80  | D 180 x 18 x 6,2 x 5,0   | 26,62  |
| M | 10x1,50 | 8,50  | D 200 x 20 x 7,0 x 5,5   | 28,68  |
| M | 12x1,75 | 10,20 | D 220 x 22 x 8,5 x 6,5   | 32,46  |
| M | 14x2,00 | 12,00 | D 220 x 25 x 10,5 x 8,0  | 60,21  |
| M | 16x2,00 | 14,00 | D 220 x 28 x 12,5 x 10,0 | 70,83  |
| M | 18x2,50 | 15,50 | D 250 x 32 x 14,0 x 11,0 | 128,87 |
| M | 20x2,50 | 17,50 | D 250 x 32 x 16,0 x 12,0 | 139,28 |
| M | 22x2,50 | 19,50 | D 250 x 35 x 18,0 x 14,5 | 163,45 |
| M | 24x3,00 | 21,00 | D 250 x 38 x 18,0 x 14,5 | 199,38 |

**35°**

**HSSCo  
5%**
**BRILLANT**
**TOL  
6H**
**R  
QUEUE  
RENFORCÉE**
**DIN  
371**
**D  
QUEUE  
DÉGAGÉE**
**DIN  
376**

|   |   |  |  | M4L                |
|---|---|--|--|--------------------|
|  |  |  | $L_1 \times L_2 \times D_2 \times \square$<br>mm | ENTRÉE<br>35°<br>€ |
| M   | 3x0,50  | 2,50   | R 100 x 10 x 3,5 x 2,7                           | 20,13              |
| M   | 4x0,70  | 3,30   | R 120 x 12 x 4,5 x 3,4                           | 21,01              |
| M   | 5x0,80  | 4,20   | R 140 x 14 x 6,0 x 4,9                           | 23,06              |
| M   | 6x1,00  | 5,00   | R 160 x 16 x 6,0 x 4,9                           | 24,39              |
| M   | 7x1,00  | 6,00   | R 160 x 17 x 7,0 x 5,5                           | 28,72              |
| M   | 8x1,25  | 6,80   | R 180 x 18 x 8,0 x 6,2                           | 28,51              |

**QUEUE DÉGAGÉE**

|   |         |       |                          | M4L-D  |
|---|---------|-------|--------------------------|--------|
| M |         | D     |                          | €      |
| M | 6x1,00  | 5,00  | D 160 x 16 x 4,5 x 3,4   | 26,27  |
| M | 8x1,25  | 6,80  | D 180 x 18 x 6,2 x 5,0   | 30,75  |
| M | 10x1,50 | 8,50  | D 200 x 20 x 7,0 x 5,5   | 34,65  |
| M | 12x1,75 | 10,20 | D 220 x 22 x 8,5 x 6,5   | 36,03  |
| M | 14x2,00 | 12,00 | D 220 x 25 x 10,5 x 8,0  | 67,46  |
| M | 16x2,00 | 14,00 | D 220 x 28 x 12,5 x 10,0 | 97,79  |
| M | 18x2,50 | 15,50 | D 250 x 32 x 14,0 x 11,0 | 145,92 |
| M | 20x2,50 | 17,50 | D 250 x 32 x 16,0 x 12,0 | 155,30 |
| M | 22x2,50 | 19,50 | D 250 x 25 x 18,0 x 14,5 | 187,97 |
| M | 24x3,00 | 21,00 | D 250 x 32 x 18,0 x 14,5 | 229,29 |



**TARAUDS-ÉCROUS PAS MÉTRIQUE DIN 357**



**HSSCo**  
5%

**BRILLANT**

**TOL**  
6H

**DIN**  
357

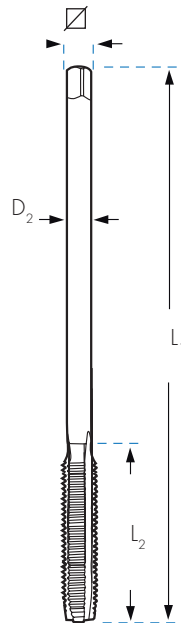

|            |       |   | L <sub>1</sub> x L <sub>2</sub> x D <sub>2</sub> x $\square$<br>mm | MTU               |
|------------|-------|---|--|-------------------|
|            |       |   |  | ENTRÉE<br>FORME A |
|            |       |   |  | €                 |
| M 3x0,50** | 2,50  | D | 70 x 22 x 2,2  | 23,20             |
| M 4x0,70   | 3,30  | D | 90 x 25 x 2,8 x 2,1  | 23,20             |
| M 5x0,80   | 4,20  | D | 100 x 28 x 3,5 x 2,7   | 23,20             |
| M 6x1,00   | 5,00  | D | 110 x 32 x 4,5 x 3,4   | 23,20             |
| M 8x1,25   | 6,80  | D | 125 x 40 x 6,0 x 4,9   | 28,29             |
| M 10x1,50  | 8,50  | D | 140 x 45 x 7,0 x 5,5   | 30,44             |
| M 12x1,75  | 10,20 | D | 180 x 50 x 9,0 x 7,0   | 50,00             |
| M 14x2,00  | 12,00 | D | 200 x 56 x 11,0 x 9,0  | 58,25             |
| M 16x2,00  | 14,00 | D | 200 x 63 x 12,0 x 9,0  | 72,12             |
| M 18x2,50  | 15,50 | D | 220 x 63 x 14,0 x 11,0   | 97,03             |
| M 20x2,50  | 17,50 | D | 250 x 70 x 16,0 x 12,0   | 123,01*           |
| M 22x2,50  | 19,50 | D | 280 x 80 x 18,0 x 14,5   | 150,91*           |
| M 24x3,00  | 21,00 | D | 280 x 80 x 18,0 x 14,5   | 205,32*           |

\*\*Queue cylindrique

\*Jusqu'à fin des stocks

Tarouds et filières  
Rose

**BLUE-MASTER**  
by CELESA

CONSULTEZ NOTRE LARGE GAMME D'OUTILS POUR  
LA RÉPARATION DE FILETAGES P. 659



FILETS  
RAPPORTÉS

DOUILLES RIGIDES  
À SCELLANT ANAÉROBIE

DOUILLES  
AUTO-TARAUDEUSES

DOUILLES RIGIDES  
DE SÉCURITÉ

**FRET TARAUDEUR HSSCo**

DIN 13

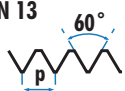

**HSSCo**  
**5%**

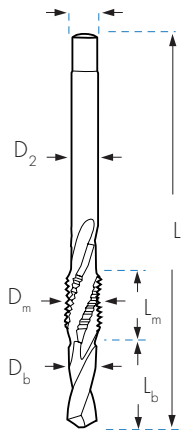
BRILLANT

**TOL**  
**6H**
**R**  
**QUEUE**  
**RENFORCÉE**
**DIN**  
**371**
**D**  
**QUEUE**  
**DÉGAGÉE**
**DIN**  
**376**

|                      |   | L <sub>b</sub><br>mm | L <sub>m</sub><br>mm | L <sub>1</sub><br>mm | D <sub>b</sub><br>mm | D <sub>m</sub><br>mm | D <sub>2</sub><br>mm | ∅<br>mm | M8M<br>€ |
|----------------------|---|----------------------|----------------------|----------------------|----------------------|----------------------|----------------------|---------|----------|
| M 3x0,50             | R | 9,0                  | 12,5                 | 62,0                 | 2,50                 | 3,0                  | 3,5                  | 2,7     | 29,64    |
| M 4x0,70             | R | 10,0                 | 16,0                 | 66,0                 | 3,30                 | 4,0                  | 4,5                  | 3,4     | 29,64    |
| M 5x0,80             | R | 12,5                 | 18,0                 | 75,5                 | 4,20                 | 5,0                  | 6,0                  | 4,9     | 31,99    |
| M 6x1,00             | R | 14,0                 | 20,0                 | 81,0                 | 5,00                 | 6,0                  | 6,0                  | 4,9     | 35,33    |
| M 8x1,00             | R | 20,0                 | 14,0                 | 91,0                 | 7,00                 | 8,0                  | 6,0                  | 4,9     | 44,46    |
| M 8x1,25             | R | 20,0                 | 14,0                 | 91,0                 | 6,75                 | 8,0                  | 8,0                  | 6,2     | 47,86    |
| <b>QUEUE DÉGAGÉE</b> |   |                      |                      |                      |                      |                      |                      |         |          |
| M 8x1,25             | D | 20,0                 | 14,0                 | 91,0                 | 6,75                 | 8,0                  | 6,0                  | 4,9     | 41,17    |
| M 10x1,00            | D | 20,0                 | 15,0                 | 95,0                 | 9,00                 | 10,0                 | 7,0                  | 5,5     | 55,19    |
| M 10x1,50            | D | 25,0                 | 18,0                 | 105,0                | 8,50                 | 10,0                 | 7,0                  | 5,5     | 44,97    |
| M 12x1,50            | D | 24,0                 | 18,0                 | 110,0                | 10,50                | 12,0                 | 9,0                  | 7,0     | 59,73    |
| M 12x1,75            | D | 28,0                 | 20,0                 | 118,0                | 10,20                | 12,0                 | 9,0                  | 7,0     | 53,41    |
| M 14x1,50            | D | 28,0                 | 20,0                 | 118,0                | 12,50                | 14,0                 | 11,0                 | 9,0     | 101,16   |
| M 14x2,00            | D | 28,0                 | 22,0                 | 130,0                | 12,00                | 14,0                 | 11,0                 | 9,0     | 97,75    |
| M 16x2,00            | D | 36,0                 | 24,0                 | 139,0                | 14,00                | 16,0                 | 12,0                 | 9,0     | 165,36   |
| M 18x2,50            | D | 40,0                 | 26,0                 | 151,0                | 15,50                | 18,0                 | 14,0                 | 11,0    | 187,51   |
| M 20x2,50            | D | 45,0                 | 30,0                 | 168,0                | 17,50                | 20,0                 | 16,0                 | 12,0    | 316,95   |

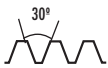
 Ne jamais utiliser les forets taraudeurs dans des trous borgnes ou débouchants plus profonds que L<sub>b</sub>.

**TARAUD MACHINE HSS À FILET TRAPÉZOÏDAL**

HSS

BRILLANT

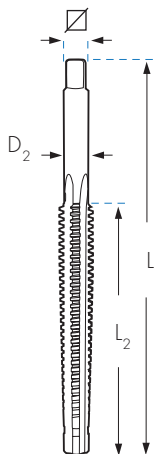

**DIN**  
**103**
**TOL**  
**7H**

|    |        | ∅     | L <sub>1</sub> x L <sub>2</sub> x D <sub>2</sub> x ∅<br>mm | MRTM<br>€ |
|----|--------|-------|--|-----------|
| Tr | 14 x 3 | 11,25 | 160 x 105 x 10,5 x 8,0                                     | 364,42    |
| Tr | 16 x 4 | 12,25 | 205 x 110 x 11,5 x 9,0                                     | 395,86    |
| Tr | 18 x 4 | 14,25 | 215 x 120 x 13,0 x 10,0                                    | 405,70    |
| Tr | 20 x 4 | 16,25 | 230 x 130 x 15,0 x 12,0                                    | 425,07    |
| Tr | 22 x 5 | 17,25 | 270 x 165 x 16,0 x 12,0                                    | 551,86    |
| Tr | 24 x 5 | 19,25 | 280 x 165 x 18,0 x 14,5                                    | 634,65    |
| Tr | 26 x 5 | 21,25 | 290 x 170 x 20,0 x 16,0                                    | 656,67    |
| Tr | 28 x 5 | 23,25 | 300 x 180 x 22,0 x 18,0                                    | 733,68    |
| Tr | 30 x 6 | 24,25 | 345 x 200 x 23,0 x 18,0                                    | 867,81    |

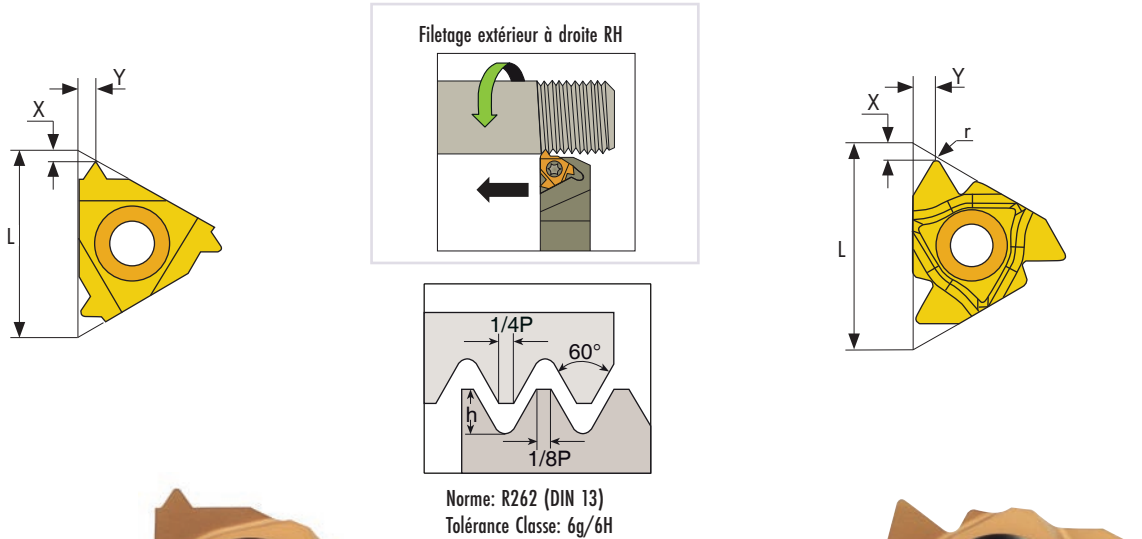
## PLAQUETTES POUR FILETAGE EXTÉRIEUR

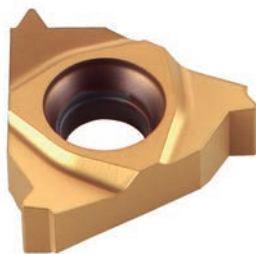
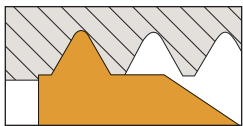

Profil complet



Profil Partiel

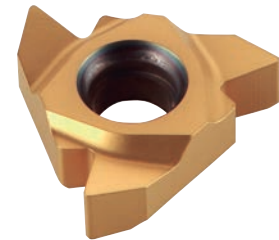
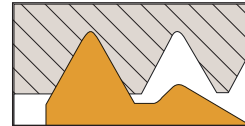

Réalise un profil complet, incluant le diamètre extérieur du filetage. On utilisera une plaquette différente pour chaque pas.

Ne termine pas le diamètre extérieur du filetage. La même plaquette peut être utilisée pour différents pas ayant le même angle de filetage.

### PROFIL COMPLET 60°

| FILETAGE EXTÉRIEUR | L  | PAS  | h    | X   | Y   | €      |
|--------------------|----|------|------|-----|-----|--------|
| PRE-16-075         | 16 | 0,75 | 0,46 | 0,6 | 0,6 | 24,57* |
| PRE-16-100         |    | 1,00 | 0,61 | 0,7 | 0,7 | 24,57* |
| PRE-16-125         |    | 1,25 | 0,77 | 0,8 | 0,9 | 24,57* |
| PRE-16-150         |    | 1,50 | 0,92 | 0,8 | 1   | 24,57* |
| PRE-16-175         |    | 1,75 | 1,07 | 0,9 | 1,2 | 24,57* |
| PRE-16-200         |    | 2,00 | 1,23 | 1   | 1,3 | 24,57* |
| PRE-16-250         |    | 2,50 | 1,53 | 1,1 | 1,5 | 24,57* |
| PRE-16-300         |    | 3,00 | 1,84 | 1,2 | 1,6 | 24,57* |

\*Jusqu'à fin de stock

### PROFIL PARTIEL 60°

| FILETAGE EXTÉRIEUR | L  | ECHELLE MÉTRIQUES | ECHELLE POUÇES | r    | X    | Y    | €      |
|--------------------|----|-------------------|----------------|------|------|------|--------|
| PPRE-16-150        | 16 | 0,50-1,50         | 48 - 16        | 0,05 | 0,80 | 0,90 | 24,57* |
| PPRE-16-300        |    | 1,75-3,00         | 14 - 8         | 0,27 | 1,20 | 1,70 | 24,57* |

\*Jusqu'à fin de stock

### PORTE-OUTILS POUR FILETAGE EXTÉRIEUR

| FILETAGE EXTÉRIEUR | H1=H=B=F | L1  | L2 | €       |
|--------------------|----------|-----|----|---------|
| PEXT-25-16         | 25       | 153 | 30 | 179,66* |

\*Jusqu'à fin de stock

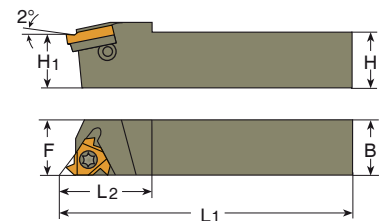

|   |               |                  |               |
|---|---------------|------------------|---------------|
|   | <b>Vc</b>     |                  | <b>Vc</b>     |
| <b>ACIER</b><br>70 kg/mm <sup>2</sup>         | 25<br>m / min | <b>ALUMINIUM</b> | 50<br>m / min |
| <b>ACIER TREMPÉ</b><br>120 kg/mm <sup>2</sup> | 13<br>m / min | <b>TITANE</b>    | 18<br>m / min |
| <b>INOX</b>                                   | 11<br>m / min | <b>FONTE</b>     | 25<br>m / min |
|   |               | <b>LAITON</b>    | 50<br>m / min |

### FORMULE MATHÉMATIQUE POUR OBTENIR LA VITESSE DE ROTATION DE LA PIÈCE (RPM)

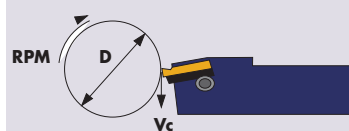

RPM : Tour/min  
Vc : Vitesse de coupe (m/min)  
D : Diamètre pièce (mm)

$$RPM = \frac{1000 \times Vc}{\pi \times D}$$

Les RPM sont obtenues en fonction de Vc et D

**PLAQUETTES POUR FILETAGE INTÉRIEUR**

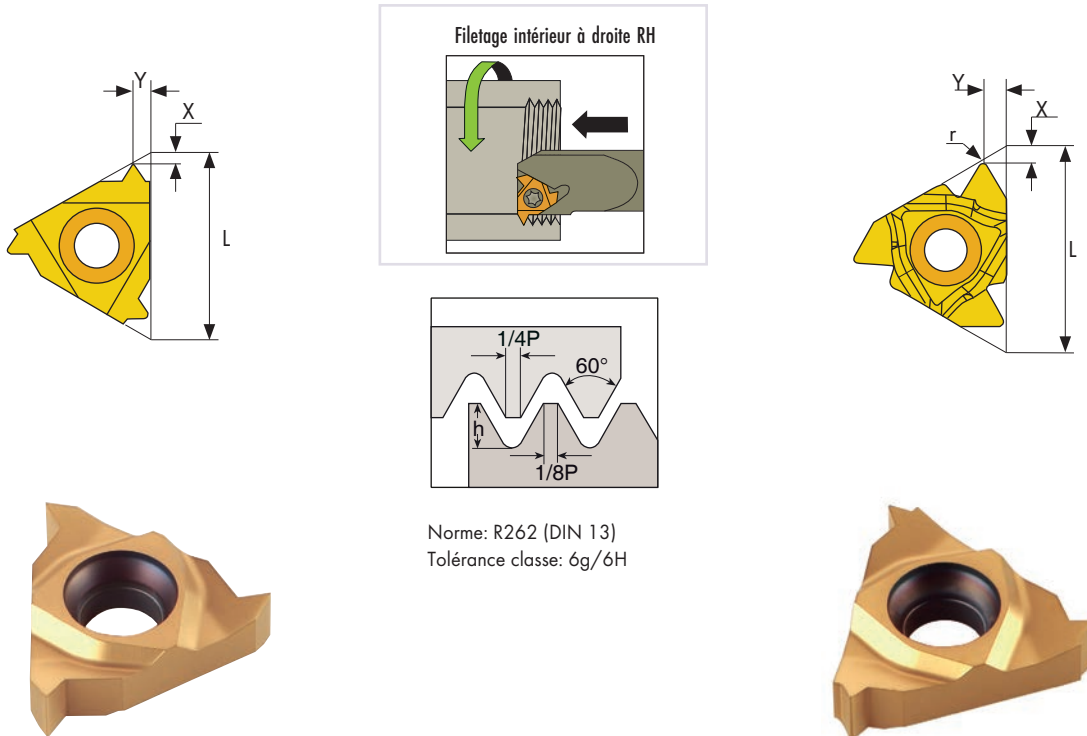

Norme: R262 (DIN 13)  
Tolérance classe: 6g/6H

**PROFIL COMPLET 60°**

| FILETAGE INTÉRIEUR | L  | PAS  | h    | X   | Y   | €      |
|--------------------|----|------|------|-----|-----|--------|
| PRI-16-075         | 16 | 0,75 | 0,43 | 0,6 | 0,6 | 24,57* |
| PRI-16-100         |    | 1,00 | 0,58 | 0,6 | 0,7 | 24,57* |
| PRI-16-125         |    | 1,25 | 0,72 | 0,8 | 0,9 | 24,57* |
| PRI-16-150         |    | 1,50 | 0,87 | 0,8 | 1,0 | 24,57* |
| PRI-16-175         |    | 1,75 | 1,01 | 0,9 | 1,2 | 24,57* |
| PRI-16-200         |    | 2,00 | 1,15 | 1,0 | 1,3 | 24,57* |
| PRI-16-250         |    | 2,50 | 1,44 | 1,1 | 1,5 | 24,57* |
| PRI-16-300         |    | 3,00 | 1,73 | 1,1 | 1,5 | 24,57* |

\*Jusqu'à fin de stock

**PROFIL PARTIEL 60°**

| FILETAGE INTÉRIEUR | L  | ECHELLE MÉTRIQUES | ECHELLE POUCES | r    | X    | Y    | €      |
|--------------------|----|-------------------|----------------|------|------|------|--------|
| PPRI-16-150        | 16 | 0,50-1,50         | 48 - 16        | 0,05 | 0,80 | 0,90 | 24,57* |
| PPRI-16-300        |    | 1,75-3,00         | 14 - 8         | 0,16 | 1,20 | 1,70 | 24,57* |

\*Jusqu'à fin de stock

**PORTE-OUTILS POUR FILETAGE INTÉRIEUR**

| FILETAGE INTÉRIEUR | L   | L1 | D  | D1   | A    | ∅ Min. trou | €       |
|--------------------|-----|----|----|------|------|-------------|---------|
| PINT-20-16         | 180 | 40 | 20 | 20   | 18   | 24          | 177,08* |
| PINT-25-16         | 200 | 45 | 25 | 24,6 | 22,6 | 29          | 216,52* |

\*Jusqu'à fin de stock

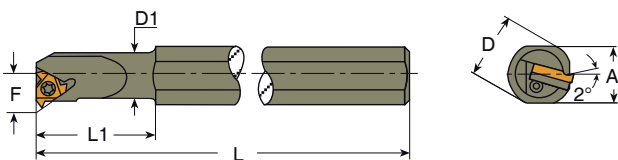

**TARAUDS MACHINE HSSCo EN COFFRETS MÉTALLIQUES**

**USAGE  
GÉNÉRAL**

**HSSCo  
5%**



Réf. JM6



Réf. JM2





Réf. JM8



Réf. JM4



**CONTENU**

|     | ENTRÉE DROITE                       | ENTRÉE GUN                          |  15° |  35° |  HSS | HSSCo 5%<br>€ |
|-----|-------------------------------------|-------------------------------------|--|---|--|---------------|
| JM5 | M3 - M4 - M5 - M6<br>M8 - M10 - M12 | -                                   | -  | -   | -  | 103,24        |
| JM1 | M3 - M4 - M5 - M6<br>M8 - M10 - M12 | -                                   | -  | -   | 2.5 / 3.3 / 4.2 / 5.0<br>6.8 / 8.5 / 10.2 mm   | 126,98        |
| JM6 | -                                   | M3 - M4 - M5 - M6<br>M8 - M10 - M12 | -  | -   | -  | 109,39        |
| JM2 | -                                   | M3 - M4 - M5 - M6<br>M8 - M10 - M12 | -  | -   | 2.5 / 3.3 / 4.2 / 5.0<br>6.8 / 8.5 / 10.2 mm   | 133,14        |
| JM7 | -                                   | -                                   | M3 - M4 - M5 - M6<br>M8 - M10 - M12  | -   | -  | 140,35        |
| JM3 | -                                   | -                                   | M3 - M4 - M5 - M6<br>M8 - M10 - M12  | -   | 2.5 / 3.3 / 4.2 / 5.0<br>6.8 / 8.5 / 10.2 mm   | 164,10        |
| JM8 | -                                   | -                                   | -  | M3 - M4 - M5 - M6<br>M8 - M10 - M12   | -  | 129,32        |
| JM4 | -                                   | -                                   | -  | M3 - M4 - M5 - M6<br>M8 - M10 - M12   | 2.5 / 3.3 / 4.2 / 5.0<br>6.8 / 8.5 / 10.2 mm   | 153,06        |

**TARAUDS MACHINE EN COFFRETS MÉTALLIQUES**
**Plus**

Réf. JMPT2



**CONTENU**

|      | ENTRÉE GUN                          | BRILLANT |  35° | BRILLANT |  HSSCo 5% | HSS PM<br>€ |       | TiN<br>€ |
|------|-------------------------------------|----------|---|----------|--|-------------|-------|----------|
| JMP6 | M3 - M4 - M5 - M6<br>M8 - M10 - M12 |          | -   |          | -  | 123,81      | JMPT6 | 179,31   |
| JMP2 | M3 - M4 - M5 - M6<br>M8 - M10 - M12 |          | -   |          | 2.5 / 3.3 / 4.2 / 5.0<br>6.8 / 8.5 / 10.2 mm   | 167,59      | JMPT2 | 223,10   |
| JMP8 | -                                   |          | M3 - M4 - M5 - M6<br>M8 - M10 - M12   |          | -  | 143,94      | JMPT8 | 196,51   |
| JMP4 | -                                   |          | M3 - M4 - M5 - M6<br>M8 - M10 - M12   |          | 2.5 / 3.3 / 4.2 / 5.0<br>6.8 / 8.5 / 10.2 mm   | 187,73      | JMPT4 | 240,29   |

**INOX**
**CONTENU**

|      | ENTRÉE GUN                          | OX |  35° | OX |  HSSCo 5% | HSS PM<br>€ |       | TiN<br>€ |
|------|-------------------------------------|----|---|----|--|-------------|-------|----------|
| JMX6 | M3 - M4 - M5 - M6<br>M8 - M10 - M12 |    | -   |    | -  | 139,45      | JMXT6 | 169,72   |
| JMX2 | M3 - M4 - M5 - M6<br>M8 - M10 - M12 |    | -   |    | 2.5 / 3.3 / 4.2 / 5.0<br>6.8 / 8.5 / 10.2 mm   | 183,24      | JMXT2 | 213,51   |
| JMX8 | -                                   |    | M3 - M4 - M5 - M6<br>M8 - M10 - M12   |    | -  | 170,52      | JMXT8 | 196,65   |
| JMX4 | -                                   |    | M3 - M4 - M5 - M6<br>M8 - M10 - M12   |    | 2.5 / 3.3 / 4.2 / 5.0<br>6.8 / 8.5 / 10.2 mm   | 214,31      | JMXT4 | 240,44   |

**1200**  
 N/mm<sup>2</sup>
**CONTENU**

|       | ENTRÉE GUN                          | OX |  35° | OX |  HSSCo 5% | HSS V3<br>€ |        | TINALOX<br>€ |
|-------|-------------------------------------|----|---|----|--|-------------|--------|--------------|
| JMMD6 | M3 - M4 - M5 - M6<br>M8 - M10 - M12 |    | -   |    | -  | 155,09      | JMMDT6 | 221,84       |
| JMMD2 | M3 - M4 - M5 - M6<br>M8 - M10 - M12 |    | -   |    | 2.5 / 3.3 / 4.2 / 5.0<br>6.8 / 8.5 / 10.2 mm   | 198,87      | JMMDT2 | 265,61       |
| JMMD8 | -                                   |    | M3 - M4 - M5 - M6<br>M8 - M10 - M12   |    | -  | 170,17      | JMMDT8 | 254,10       |
| JMMD4 | -                                   |    | M3 - M4 - M5 - M6<br>M8 - M10 - M12   |    | 2.5 / 3.3 / 4.2 / 5.0<br>6.8 / 8.5 / 10.2 mm   | 213,95      | JMMDT4 | 297,88       |

**TARAUDS MACHINE HSSCo EN COFFRETS MÉTALLIQUES**

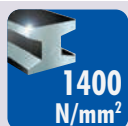

Réf. JMC2

**CONTENU**

|      | ENTRÉE GUN                          | TiCN | 15°                                 | TiCN | HSSCo 5%                                     | HSS-PM<br>€ |
|------|-------------------------------------|------|-------------------------------------|------|--|-------------|
| JMC6 | M3 - M4 - M5 - M6<br>M8 - M10 - M12 |      | -                                   |      | -  | 254,32      |
| JMC2 | M3 - M4 - M5 - M6<br>M8 - M10 - M12 |      | -                                   |      | 2.5 / 3.3 / 4.2 / 5.0<br>6.8 / 8.5 / 10.2 mm | 298,09      |
| JMC8 | -                                   |      | M3 - M4 - M5 - M6<br>M8 - M10 - M12 |      | -  | 287,05      |
| JMC4 | -                                   |      | M3 - M4 - M5 - M6<br>M8 - M10 - M12 |      | 2.5 / 3.3 / 4.2 / 5.0<br>6.8 / 8.5 / 10.2 mm | 330,84      |

**TOUT TERRAIN**

**CONTENU**

|      | ENTRÉE GUN                          | TiN | 35°                                 | TiN | HSSCo 5%                                     | HSSCo 5%<br>€ |
|------|-------------------------------------|-----|-------------------------------------|-----|--|---------------|
| JMD6 | M3 - M4 - M5 - M6<br>M8 - M10 - M12 |     | -                                   |     | -  | 210,57        |
| JMD2 | M3 - M4 - M5 - M6<br>M8 - M10 - M12 |     | -                                   |     | 2.5 / 3.3 / 4.2 / 5.0<br>6.8 / 8.5 / 10.2 mm | 254,35        |
| JMD8 | -                                   |     | M3 - M4 - M5 - M6<br>M8 - M10 - M12 |     | -  | 240,36        |
| JMD4 | -                                   |     | M3 - M4 - M5 - M6<br>M8 - M10 - M12 |     | 2.5 / 3.3 / 4.2 / 5.0<br>6.8 / 8.5 / 10.2 mm | 284,13        |

**AI**

**CONTENU**

|       | FILET ALTERNÉ                       | BRILLANT | 2 GOUJURES                          | BRILLANT | HSS  | HSSCo 5%<br>€ |
|-------|-------------------------------------|----------|-------------------------------------|----------|--|---------------|
| JMAL6 | M3 - M4 - M5 - M6<br>M8 - M10 - M12 |          | -                                   |          | -  | 148,56        |
| JMAL2 | M3 - M4 - M5 - M6<br>M8 - M10 - M12 |          | -                                   |          | 2.5 / 3.3 / 4.2 / 5.0<br>6.8 / 8.5 / 10.2 mm | 172,95        |
| JMAL8 | -                                   |          | M3 - M4 - M5 - M6<br>M8 - M10 - M12 |          | -  | 174,71        |
| JMAL4 | -                                   |          | M3 - M4 - M5 - M6<br>M8 - M10 - M12 |          | 2.5 / 3.3 / 4.2 / 5.0<br>6.8 / 8.5 / 10.2 mm | 198,45        |

**TARAUDS MACHINE EN COFFRET PLASTIQUE**
**USAGE  
GÉNÉRAL**
**CONTENU**

|      | ENTRÉE<br>GUN            | BRILLANT |  35° | BRILLANT | HSSCo 5% |
|------|--------------------------|----------|---|----------|----------|
|      |                          |          |   |          | €        |
| PT01 | M4 - M5 - M6<br>M8 - M10 |          | M4 - M5 - M6<br>M8 - M10  |          | 140,47   |



Réf. PT01

**Plus**
**CONTENU**

|      | ENTRÉE<br>GUN            | BRILLANT |  35° | BRILLANT | HSS PM |      | TiN    |
|------|--------------------------|----------|---|----------|--------|------|--------|
|      |                          |          |   |          | €      |      | €      |
| PT02 | M4 - M5 - M6<br>M8 - M10 |          | M4 - M5 - M6<br>M8 - M10  |          | 154,58 | PT03 | 226,98 |



Réf. PT03

**INOX**
**CONTENU**

|      | ENTRÉE<br>GUN            | OX |  35° | OX | HSS PM |      | TiN    |
|------|--------------------------|----|---|----|--------|------|--------|
|      |                          |    |   |    | €      |      | €      |
| PT05 | M4 - M5 - M6<br>M8 - M10 |    | M4 - M5 - M6<br>M8 - M10  |    | 179,77 | PT13 | 216,13 |



Réf. PT05

**CONTENU**

|      | ENTRÉE<br>GUN            | OX |  35° | OX | HSS V3 |      | TINALOX |
|------|--------------------------|----|---|----|--------|------|---------|
|      |                          |    |   |    | €      |      | €       |
| PT04 | M4 - M5 - M6<br>M8 - M10 |    | M4 - M5 - M6<br>M8 - M10  |    | 190,76 | PT14 | 285,92  |

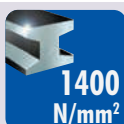

Réf. PT04

**CONTENU**

|      | ENTRÉE<br>GUN            | TiCN |  15° | TiCN | HSS PM |
|------|--------------------------|------|---|------|--------|
|      |                          |      |   |      | €      |
| PT11 | M4 - M5 - M6<br>M8 - M10 |      | M4 - M5 - M6<br>M8 - M10  |      | 329,71 |



Réf. PT11



**TARAUDS MACHINE EN COFFRET PLASTIQUE**

**Al**



Réf. PT06

**CONTENU**

|      | FILET ALTERNÉ            | 2 GOUJURES               | HSSCo 5%<br>€ |
|------|--------------------------|--------------------------|---------------|
| PT06 | M4 - M5 - M6<br>M8 - M10 | M4 - M5 - M6<br>M8 - M10 | 191,38        |

**Fonte**



Réf. PT07

**CONTENU**

|      | ENTRÉE DROITE                                      | HSSCo 5%<br>€ |
|------|--|---------------|
| PT07 | M4 - M5 - M6 - M8 - M10<br>M4 - M5 - M6 - M8 - M10 | 155,83        |

**LAITON**



Réf. PT10

**CONTENU**

|      | ENTRÉE DROITE                                      | HSSCo 5%<br>€ |
|------|--|---------------|
| PT10 | M4 - M5 - M6 - M8 - M10<br>M4 - M5 - M6 - M8 - M10 | 189,41        |



**LAMINAGE**



Réf. PT08

**CONTENU**

|      |  | HSSCo 5%<br>€ |
|------|---|---------------|
| PT08 | M4 - M5 - M6 - M8 - M10<br>M4 - M5 - M6 - M8 - M10                                    | 316,42        |



Réf. PT09

**CONTENU**

|      |  | HSSCo 5%<br>€ |
|------|--|---------------|
| PT09 | M4 - M5 - M6 - M8 - M10<br>M4 - M5 - M6 - M8 - M10 | 351,07        |

**TOL 6G**



Réf. PT12

**CONTENU**

|      | ENTRÉE GUN               |  35° | HSSCo 5%<br>€ |
|------|--------------------------|---|---------------|
| PT12 | M4 - M5 - M6<br>M8 - M10 | M4 - M5 - M6<br>M8 - M10  | 169,90        |

**PRÉSENTOIRS EN MÉTHACRYLATE POUR TARAUDS MACHINE**
**PRÉSENTOIR EN MÉTHACRYLATE**

MM-03

Contenu: Tarauds machine, série standard

**HSSCo**  
**5%**
**ENTRÉE**  
**GUN**

Trous débouchants: Ref. M2

|           |           |           |           |            |            |            |
|-----------|-----------|-----------|-----------|------------|------------|------------|
| <u>M4</u> | <u>M5</u> | <u>M6</u> | <u>M8</u> | <u>M10</u> | <u>M12</u> | <u>M14</u> |
| 5         | 10        | 10        | 10        | 10         | 5          | 4          |

Trous Borgnes: Ref. M4



|           |           |           |           |            |            |            |
|-----------|-----------|-----------|-----------|------------|------------|------------|
| <u>M4</u> | <u>M5</u> | <u>M6</u> | <u>M8</u> | <u>M10</u> | <u>M12</u> | <u>M14</u> |
| 5         | 10        | 10        | 10        | 10         | 5          | 4          |

Dimensions: largeur 240 x profondeur 240 x hauteur 245 mm.

1.824,63 €



Réf. MM-03



Réf. MM-04

**PRÉSENTOIR EN MÉTHACRYLATE**

MM-04

Contenu: Tarauds machine, Série Plus  
Fabriqués en acier Fritté (ASP)
**HSS**  
**PM**
*Plus*
**ENTRÉE**  
**GUN**

Trous débouchants: Ref. M2

|           |           |           |           |            |            |            |
|-----------|-----------|-----------|-----------|------------|------------|------------|
| <u>M4</u> | <u>M5</u> | <u>M6</u> | <u>M8</u> | <u>M10</u> | <u>M12</u> | <u>M14</u> |
| 5         | 10        | 10        | 10        | 10         | 5          | 4          |



Trous Borgnes: Ref. M4

|           |           |           |           |            |            |            |
|-----------|-----------|-----------|-----------|------------|------------|------------|
| <u>M4</u> | <u>M5</u> | <u>M6</u> | <u>M8</u> | <u>M10</u> | <u>M12</u> | <u>M14</u> |
| 5         | 10        | 10        | 10        | 10         | 5          | 4          |

Dimensions: largeur 240 x profondeur 240 x hauteur 245 mm.

2.117,78 €

**PRÉSENTOIR EN MÉTHACRYLATE**

MM-05

Contenu: Tarauds machine pour travaux spéciaux

**ENTRÉE**  
**GUN**

Trous débouchants: Ref. M2



|           |           |           |           |            |            |            |
|-----------|-----------|-----------|-----------|------------|------------|------------|
| <u>M4</u> | <u>M5</u> | <u>M6</u> | <u>M8</u> | <u>M10</u> | <u>M12</u> | <u>M14</u> |
| 1         | 2         | 2         | 2         | 2          | 1          | 1          |



|           |           |           |           |            |            |            |
|-----------|-----------|-----------|-----------|------------|------------|------------|
| <u>M4</u> | <u>M5</u> | <u>M6</u> | <u>M8</u> | <u>M10</u> | <u>M12</u> | <u>M14</u> |
| 1         | 2         | 2         | 2         | 2          | 1          | 1          |



|           |           |           |           |            |            |            |
|-----------|-----------|-----------|-----------|------------|------------|------------|
| <u>M4</u> | <u>M5</u> | <u>M6</u> | <u>M8</u> | <u>M10</u> | <u>M12</u> | <u>M14</u> |
| 1         | 2         | 2         | 2         | 2          | 1          | 1          |



|           |           |           |           |            |            |            |
|-----------|-----------|-----------|-----------|------------|------------|------------|
| <u>M4</u> | <u>M5</u> | <u>M6</u> | <u>M8</u> | <u>M10</u> | <u>M12</u> | <u>M14</u> |
| 1         | 2         | 2         | 2         | 2          | 1          | 1          |



|           |           |           |           |            |            |
|-----------|-----------|-----------|-----------|------------|------------|
| <u>M4</u> | <u>M5</u> | <u>M6</u> | <u>M8</u> | <u>M10</u> | <u>M12</u> |
| 1         | 2         | 2         | 2         | 2          | 1          |



Trous Borgnes: Ref. M4



|           |           |           |           |            |            |            |
|-----------|-----------|-----------|-----------|------------|------------|------------|
| <u>M4</u> | <u>M5</u> | <u>M6</u> | <u>M8</u> | <u>M10</u> | <u>M12</u> | <u>M14</u> |
| 1         | 2         | 2         | 2         | 2          | 1          | 1          |



|           |           |           |           |            |            |            |
|-----------|-----------|-----------|-----------|------------|------------|------------|
| <u>M4</u> | <u>M5</u> | <u>M6</u> | <u>M8</u> | <u>M10</u> | <u>M12</u> | <u>M14</u> |
| 1         | 2         | 2         | 2         | 2          | 1          | 1          |



|           |           |           |           |            |            |            |
|-----------|-----------|-----------|-----------|------------|------------|------------|
| <u>M4</u> | <u>M5</u> | <u>M6</u> | <u>M8</u> | <u>M10</u> | <u>M12</u> | <u>M14</u> |
| 1         | 2         | 2         | 2         | 2          | 1          | 1          |



|           |           |           |           |            |            |            |
|-----------|-----------|-----------|-----------|------------|------------|------------|
| <u>M4</u> | <u>M5</u> | <u>M6</u> | <u>M8</u> | <u>M10</u> | <u>M12</u> | <u>M14</u> |
| 1         | 2         | 2         | 2         | 2          | 1          | 1          |



|           |           |           |           |            |            |
|-----------|-----------|-----------|-----------|------------|------------|
| <u>M4</u> | <u>M5</u> | <u>M6</u> | <u>M8</u> | <u>M10</u> | <u>M12</u> |
| 1         | 2         | 2         | 2         | 2          | 1          |

Dimensions: Largeur 240 x profondeur 240 x hauteur 245 mm.

2.846,22 €