

THREADING TOOLS

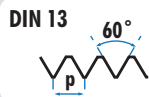

BLUE-MASTER[®]
by celesa

CUTTING TECHNOLOGIES

HSS HAND TAPS AND DIES

Ref. M0

HSS

(M)

DIN
352

(MF)

DIN
2181TOL
6H

Ref. C5

HSS

DIN
223TOL
6g

For hardness materials up to 38 HRC

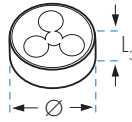
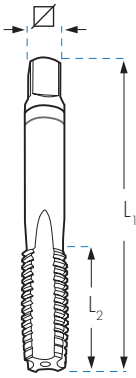

		M0			C5	
		L1 x L2 x mm	€	Ø x L3 mm	€	€
M 1x0,20	2	0,80	32 x 5,5 x 2,1	91,57		
M 1x0,25	3	0,75	32 x 6,0 x 2,1	91,57	16 x 5	95,21
M 1,1x0,20	2	0,90	32 x 5,5 x 2,1	91,57		
M 1,1x0,25	3	0,85	32 x 6,0 x 2,1	91,57	16 x 5	94,17
M 1,2x0,20	2	1,00	32 x 5,5 x 2,1	91,57		
M 1,2x0,25	3	0,95	32 x 6,0 x 2,1	91,57	16 x 5	88,36
M 1,4x0,20	2	1,20	32 x 7,0 x 2,1	91,57		
M 1,4x0,25	2	1,15	32 x 7,0 x 2,1	91,57		
M 1,4x0,30	3	1,10	32 x 7,0 x 2,1	91,57	16 x 5	83,27
M 1,6x0,20	2	1,40	32 x 8,0 x 2,1	83,55		
M 1,6x0,25	2	1,35	32 x 8,0 x 2,1	83,55		
M 1,6x0,35	3	1,25	32 x 8,0 x 2,1	83,55	16 x 5	78,67
M 1,7x0,35	3	1,35	32 x 8,0 x 2,1	78,42	16 x 5	78,67
M 1,8x0,20	2	1,60	32 x 8,0 x 2,1	78,42		
M 1,8x0,25	2	1,55	32 x 8,0 x 2,1	78,42		
M 1,8x0,35	3	1,45	32 x 8,0 x 2,1	78,42	16 x 5	78,67
M 2x0,25	2	1,75	36 x 8,0 x 2,1	78,42		
M 2x0,35	2	1,65	36 x 8,0 x 2,1	78,42		
M 2x0,40	3	1,60	36 x 9,0 x 2,1	39,33*	16 x 5	32,48*
M 2,2x0,45	3	1,75	36 x 9,0 x 2,1	44,66	20 x 5	69,45
M 2,3x0,40	3	1,90	36 x 9,0 x 2,1	41,21	20 x 5	35,62
M 2,5x0,45	3	2,05	40 x 9,0 x 2,1	39,19	20 x 5	32,48
M 2,6x0,45	3	2,10	40 x 9,0 x 2,1	40,06	25 x 9	34,00
M 3x0,35	2	2,65	40 x 9,0 x 2,7	51,21	20 x 5	51,43
M 3x0,50	3	2,50	40 x 11,0 x 2,7	22,08*	25 x 9	29,54*
M 3x0,60	3	2,40	45 x 13,0 x 3,0	44,90	20 x 5	40,30
M 3,5x0,60	3	2,90	45 x 13,0 x 3,0	26,33	25 x 9	30,91
M 3,5x0,75	3	2,75	45 x 18,0 x 3,0	48,76	25 x 9	69,50
M 4x0,50	2	3,50	45 x 13,0 x 3,4	44,27	25 x 9	33,19
M 4x0,70	3	3,30	45 x 13,0 x 3,4	22,06*	25 x 9	29,69*
M 4x0,75	3	3,25	45 x 13,0 x 3,4	36,52	20 x 7	44,90
M 4x0,80	3	3,20	45 x 13,0 x 3,4	87,99	20 x 7	106,14
M 4,5x0,50	2	4,00	50 x 12,0 x 4,9	42,95	25 x 9	46,23
M 4,5x0,75	3	3,75	50 x 16,0 x 4,9	39,33	20 x 7	32,49
M 5x0,50	2	4,50	50 x 12,0 x 4,9	44,07	20 x 5	36,24
M 5x0,75	2	4,25	50 x 14,0 x 4,9	43,76	20 x 7	45,13
M 5x0,80	3	4,20	50 x 16,0 x 4,9	23,58*	25 x 9	29,52*
M 5x0,90	3	4,10	50 x 16,0 x 4,9	41,70	25 x 9	45,13
M 5x1,00	3	4,00	50 x 16,0 x 4,9	92,91	25 x 9	102,33
M 5,5x0,90	3	4,60	50 x 16 x 4,9	92,91		
M 6x0,50	2	5,50	50 x 14 x 4,9	31,55		
M 6x0,75	2	5,25	50 x 14 x 4,9	26,63		
M 6x1,00	3	5,00	50 x 19 x 4,9	23,58*	25 x 9	29,54*
M 6x1,25	3	4,75	50 x 19 x 4,9	152,44	25 x 9	107,13
M 7x0,75	2	6,25	50 x 14 x 4,9	34,96	25 x 9	32,87
M 7x1,00	3	6,00	50 x 19 x 4,9	28,73*	25 x 9	31,01*
M 7x1,25	3	5,75	50 x 19 x 4,9	105,92	25 x 9	128,76
M 8x0,50	2	7,50	50 x 16 x 4,9	55,65	25 x 9	49,08
M 8x0,75	2	7,25	50 x 16 x 4,9	36,63	25 x 9	35,54
M 8x1,00	2	7,00	56 x 18 x 4,9	26,50*	25 x 9	34,27*
M 8x1,25	3	6,80	56 x 22 x 4,9	28,70*	25 x 9	31,34*
M 8x1,50	3	6,50	56 x 22 x 4,9	103,02	25 x 9	111,94
M 9x1,00	2	8,00	63 x 18 x 5,5	38,81	25 x 9	38,09
M 9x1,25	3	7,80	63 x 22 x 5,5	47,02*	25 x 9	36,43*
M 10x0,50	2	9,50	63 x 18 x 5,5	57,38	30 x 10	123,69
M 10x0,75	2	9,25	63 x 18 x 5,5	58,67	30 x 11	60,81
M 10x1,00	2	9,00	63 x 18 x 5,5	28,38	38 x 10	40,32
M 10x1,25	2	8,80	70 x 24 x 5,5	28,77	38 x 10	43,01
M 10x1,50	3	8,50	70 x 24 x 5,5	35,39*	38 x 10	41,95*
M 11x0,75	2	10,25	63 x 18 x 6,2	86,15	30 x 11	133,63
M 11x1,00	2	10,00	63 x 18 x 6,2	54,27	30 x 11	63,64
M 11x1,25	2	9,75	63 x 20 x 6,2	54,27	30 x 11	63,63
M 11x1,50	3	9,50	70 x 24 x 6,2	58,99	38 x 10	50,83
M 12x0,75	2	11,25	70 x 20 x 7,0	78,33	38 x 10	69,00
M 12x1,00	2	11,00	70 x 20 x 7,0	50,32	38 x 10	60,81
M 12x1,25	2	10,75	70 x 20 x 7,0	50,17	38 x 10	58,63
M 12x1,50	2	10,50	70 x 20 x 7,0	42,75*	38 x 10	52,58*
M 12x1,75	3	10,20	75 x 29 x 7,0	49,79*	38 x 14	45,58*
M 13x0,75	2	12,25	70 x 20 x 9,0	88,52	38 x 10	121,66
M 13x1,00	2	12,00	70 x 20 x 9,0	85,22	38 x 10	64,61
M 13x1,25	2	11,75	70 x 20 x 9,0	77,80	38 x 10	86,39
M 13x1,50	2	11,50	70 x 20 x 9,0	77,80	38 x 10	67,91
M 13x1,75	3	11,25	70 x 20 x 9,0	90,02	38 x 14	72,77
M 14x0,75	2	13,25	70 x 20 x 9,0	101,73	38 x 10	114,07
M 14x1,00	2	13,00	70 x 20 x 9,0	78,43	38 x 10	68,20
M 14x1,25	2	12,80	70 x 20 x 9,0	61,26*	38 x 10	68,20*
M 14x1,50	2	12,50	70 x 20 x 9,0	47,64	38 x 10	58,06
M 14x1,75	2	12,25	70 x 20 x 9,0	95,27	38 x 14	194,25
M 14x2,00	3	12,00	80 x 30 x 9,0	55,08*	38 x 14	45,13*
M 15x1,00	2	14,00	70 x 20 x 9,0	109,88	45 x 14	73,44
M 15x1,25	2	13,75	70 x 20 x 9,0	113,85	45 x 14	113,77
M 15x1,50	2	13,50	70 x 20 x 9,0	101,93	45 x 14	78,68
M 15x2,00	3	13,00	80 x 30 x 9,0	110,13	45 x 14	98,62
M 16x1,00	2	15,00	70 x 20 x 9,0	104,04	45 x 14	83,15
M 16x1,25	2	14,75	70 x 20 x 9,0	109,51	45 x 14	69,96
M 16x1,50	2	14,50	70 x 20 x 9,0	59,28*	45 x 14	65,31*
M 16x2,00	3	14,00	80 x 32 x 9,0	78,81*	45 x 18	61,19*
M 17x1,00	2	16,00	70 x 20 x 9,0	168,03	45 x 14	118,99
M 17x1,25	2	15,75	70 x 20 x 9,0	168,03	45 x 14	118,99
M 17x1,50	2	15,50	70 x 20 x 9,0	168,03	45 x 14	118,99
M 18x1,00	2	17,00	80 x 22 x 11,0	115,67	45 x 14	87,92
M 18x1,25	2	16,75	80 x 22 x 11,0	165,12	45 x 14	91,45

* Check the price of left hand sets of taps and dies available in page 188.

* Extra-fee of 20% for adjustable die

HSS HAND TAPS AND DIES

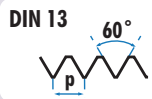

Ref. M0

(M) (MF)

HSS DIN 352 DIN 2181 TOL 6H

Ref. C5

HSS DIN 223 TOL 6g

			M0			C5						M0			C5			
Image	Quantity	Price	L1 x L2 x L3 mm	€	Ø x L3 mm	€	Image	Quantity	Price	L1 x L2 x L3 mm	€	Ø x L3 mm	€	Image	Quantity	Price	Ø x L3 mm	€
M 18x1,50	2	16,50	80 x 22 x 11,0	78,10	45 x 14	79,10	M 33x3,50	3	29,5	125 x 50 x 20,0	378,72*	65 x 25	140,34*					
M 18x2,00	2	16,00	80 x 22 x 11,0	124,66*	45 x 14	88,38*	M 34x1,50	2	32,5	100 x 25 x 22,0	389,17	65 x 18	160,62					
M 18x2,50	3	15,50	95 x 40 x 11,0	104,01*	45 x 18	61,22*	M 34x2,00	2	32,0	100 x 25 x 22,0	465,42	65 x 18	366,63					
M 19x1,00	2	18,00	80 x 22 x 11,0	243,86	45 x 14	147,58	M 35x1,50	2	33,5	100 x 25 x 22,0	415,50	65 x 18	166,60					
M 19x1,25	2	17,75	80 x 22 x 11,0	243,86	45 x 14	166,91	M 35x2,00	2	33,0	100 x 25 x 22,0	465,42	65 x 18	285,90					
M 19x1,50	2	17,50	80 x 22 x 11,0	243,86	45 x 14	147,58	M 36x1,50	2	34,5	100 x 25 x 22,0	405,66	65 x 18	157,71					
M 19x2,00	2	17,00	80 x 22 x 11,0	289,49	45 x 14	168,60	M 36x2,00	2	34,0	125 x 33 x 22,0	534,30	65 x 18	164,49					
M 20x1,00	2	19,00	80 x 22 x 12,0	157,47	45 x 14	87,92	M 36x3,00	2	33,0	125 x 33 x 22,0	692,36*	65 x 25	165,03*					
M 20x1,25	2	18,75	80 x 22 x 12,0	242,97	45 x 14	190,82	M 36x4,00	3	32,0	150 x 53 x 22,0	487,58*	65 x 25	143,08*					
M 20x1,50	2	18,50	80 x 22 x 12,0	97,81	45 x 14	80,93	M 38x1,50	2	36,5	100 x 25 x 22,0	468,86	75 x 20	240,97					
M 20x2,00	2	18,00	80 x 22 x 12,0	132,04*	45 x 14	87,92*	M 38x2,00	2	36,0	125 x 25 x 22,0	631,04	75 x 20	356,06					
M 20x2,50	3	17,50	95 x 40 x 12,0	116,68*	45 x 18	60,26*	M 39x1,50	2	37,5	110 x 25 x 24,0	620,57	75 x 20	239,69					
M 21x1,00	2	20,00	80 x 22 x 12,0	312,44	45 x 14	180,80	M 39x2,00	2	37,0	125 x 23 x 24,0	620,57	75 x 20	253,12					
M 21x1,25	2	19,75	80 x 22 x 12,0	312,44	45 x 14	180,80	M 39x3,00	2	36,0	125 x 33 x 24,0	598,60*	75 x 30	258,53*					
M 21x1,50	2	19,50	80 x 22 x 12,0	243,22	45 x 14	191,12	M 39x4,00	3	35,0	150 x 53 x 24,0	545,57*	75 x 30	217,63*					
M 22x1,00	2	21,00	80 x 22 x 14,5	176,48	55 x 16	118,35	M 40x1,50	2	38,5	110 x 25 x 24,0	550,60	75 x 20	251,78					
M 22x1,25	2	20,75	80 x 22 x 14,5	240,63	55 x 16	192,87	M 40x2,00	2	38,0	125 x 33 x 24,0	606,32	75 x 20	233,80					
M 22x1,50	2	20,50	80 x 22 x 14,5	107,57	55 x 16	101,81	M 40x3,00	2	37,0	125 x 33 x 24,0	604,10	75 x 30	254,99					
M 22x2,00	2	20,00	80 x 22 x 14,5	171,59*	55 x 16	113,28*	M 42x1,50	2	40,5	110 x 25 x 24,0	598,49	75 x 20	279,95					
M 22x2,50	3	19,50	100 x 40 x 14,5	155,42*	55 x 22	90,55*	M 42x2,00	2	40,0	125 x 33 x 24,0	709,47	75 x 20	296,02					
M 23x1,00	2	22,00	80 x 22 x 14,5	315,16	55 x 16	195,57	M 42x3,00	2	39,0	125 x 33 x 24,0	712,52	75 x 30	279,95					
M 23x1,50	2	21,50	80 x 22 x 14,5	313,93	55 x 16	231,86	M 42x4,50	3	37,5	150 x 53 x 24,0	682,61	75 x 30	217,61					
M 24x1,00	2	23,00	90 x 22 x 14,5	190,42	55 x 16	115,43	M 45x1,50	2	43,5	110 x 25 x 29,0	653,71	90 x 22	327,13					
M 24x1,25	2	22,75	90 x 22 x 14,5	311,22	55 x 16	153,25	M 45x2,00	2	43,0	125 x 33 x 29,0	852,03	90 x 22	355,13					
M 24x1,50	2	22,50	90 x 22 x 14,5	137,13	55 x 16	103,73	M 45x3,00	2	42,0	125 x 33 x 29,0	852,03	90 x 36	370,53					
M 24x2,00	2	22,00	90 x 22 x 14,5	204,61*	55 x 16	115,43*	M 45x4,50	3	40,5	160 x 60 x 29,0	788,03	90 x 36	337,20					
M 24x3,00	3	21,00	110 x 50 x 14,5	185,38*	55 x 22	90,55*	M 48x1,50	2	46,5	140 x 33 x 29,0	729,83	90 x 22	319,67					
M 25x1,00	2	24,00	90 x 22 x 14,5	268,63	55 x 16	175,18	M 48x2,00	2	46,0	140 x 33 x 29,0	1.113,54	90 x 22	350,15					
M 25x1,25	2	23,75	90 x 22 x 14,5	351,81	55 x 16	230,66	M 48x3,00	2	45,0	140 x 33 x 29,0	1.032,49	90 x 36	337,79					
M 25x1,50	2	23,50	90 x 22 x 14,5	253,44	55 x 16	150,69	M 48x5,00	3	43,0	180 x 65 x 29,0	948,78	90 x 36	337,60					
M 25x2,00	2	23,00	90 x 22 x 14,5	458,14	55 x 16	224,26	M 50x1,50	2	48,5	140 x 33 x 29,0	798,16	90 x 22	333,33					
M 26x1,00	2	25,00	90 x 22 x 14,5	240,13	55 x 16	173,63	M 50x3,00	2	57,0	140 x 33 x 29,0	1.065,89	90 x 22	363,28					
M 26x1,50	2	24,50	90 x 22 x 14,5	225,30	55 x 16	139,98	M 52x1,50	2	50,5	140 x 33 x 32,0	837,23	90 x 22	340,38					
M 26x2,00	2	24,00	90 x 22 x 14,5	264,35	55 x 16	196,21	M 52x2,00	2	50,0	140 x 33 x 32,0	1.214,75	90 x 22	395,57					
M 27x1,00	2	26,00	90 x 22 x 16,0	264,37	65 x 18	156,19	M 52x3,00	2	49,0	140 x 33 x 32,0	1.118,40	90 x 36	431,67					
M 27x1,50	2	25,50	90 x 22 x 16,0	255,26	65 x 18	156,86	M 52x5,00	3	47,0	180 x 65 x 32,0	1.136,36	90 x 36	337,60					
M 27x2,00	2	25,00	90 x 22 x 16,0	283,57*	65 x 18	170,60*	M 56x4,00	2	52,0	180 x 47 x 32,0	1.247,09	105 x 36						
M 27x3,00	3	24,00	110 x 50 x 16,0	234,42*	65 x 25	137,35*	M 56x5,50	3	50,5	200 x 85 x 35,0	1.763,76	105 x 36						
M 28x1,00	2	27,00	90 x 22 x 16,0	446,20	65 x 18	201,90	M 60x5,50	3	54,5	200 x 85 x 35,0	1.832,90	105 x 36						
M 28x1,50	2	26,50	90 x 22 x 16,0	250,28	65 x 18	142,20	M 64x4,00	2	60,0	180 x 50 x 35,0	1.756,34	120 x 36						
M 28x2,00	2	26,00	90 x 22 x 16,0	299,45	65 x 18	199,93	M 64x6,00	3	58,0	220 x 90 x 39,0	2.168,78	120 x 36						
M 30x1,00	2	29,00	90 x 22 x 18,0	277,93	65 x 18	165,52	M 68x6,00	3	62,0	220 x 90 x 39,0	2.596,44	120 x 36						
M 30x1,50	2	28,50	90 x 22 x 18,0	266,73	65 x 18	156,85	M 72x6,00	3	66,0	235 x 90 x 39,0	2.812,95	120 x 36						
M 30x2,00	2	28,00	90 x 22 x 18,0	307,51	65 x 18	173,83												
M 30x3,00	2	27,00	125 x 56 x 18,0	300,62*	65 x 25	193,63*												
M 30x3,50	3	26,50	125 x 50 x 18,0	301,60*	65 x 25	137,70*												
M 32x1,00	2	31,00	90 x 22 x 18,0	366,52	65 x 18	213,79												
M 32x1,50	2	30,50	90 x 22 x 18,0	317,59	65 x 18	162,68												
M 32x2,00	2	30,00	90 x 22 x 18,0	454,59	65 x 18	198,14												
M 33x1,00	2	32,00	100 x 25 x 20,0	584,92	65 x 18	226,37												
M 33x1,50	2	31,50	100 x 25 x 20,0	339,67	65 x 18	153,93												
M 33x2,00	2	31,00	100 x 25 x 20,0	428,84	65 x 18	154,99												
M 33x3,00	2	30,00	125 x 56 x 20,0	541,12*	65 x 25	239,18*												

DIES WITH EXTERNAL Ø AVAILABLE IN INCHES

						C5	
	Ø x L3 mm	€		Ø x L3 mm	€		
M 3x0,50	25,4 x 9,5	25,32	M 8x1,25	38,1 x 12,7	26,88		
M 4x0,70	25,4 x 9,5	25,32	M 10x1,50	25,4 x 9,5	34,02		
M 5x0,80	25,4 x 9,5	25,80	M 10x1,50	38,1 x 12,7	34,02		
M 6x1,00	25,4 x 9,5	25,32	M 12x1,75	25,4 x 9,5	40,99		
M 8x1,25	25,4 x 9,5	26,88	M 12x1,75	38,1 x 12,7	40,99		

* Check the price of left hand sets of taps and dies available in page 188.
* Extra-fee of 20% for adjustable die

HSS HAND TAPS AND DIES

UNC

Ref. M0

HSS DIN 351 TOL 2B

Ref. C5

HSS DIN 223 TOL 2a



UNF

Ref. M0

HSS DIN 2181 TOL 2B

Ref. C5

HSS DIN 223 TOL 2a



Icon	Pcs.	D1 mm	L1 mm	L2 x L3 mm	M0		C5	
					€	Ø x L3 mm	€	
UNC n°1-64h.	3	1,85	1,50	36x8x2,1	110,43	16x5		
UNC n°2-56h.	3	2,18	1,80	36x9x2,1	78,04	16x5		
UNC n°3-48h.	3	2,51	2,10	40x9x2,1	78,04	16x5		
UNC n°4-40h.	3	2,84	2,25	40x11x2,7	59,10	20x5	43,85	
UNC n°5-40h.	3	3,17	2,60	40x11x2,7	56,50	20x5	43,97	
UNC n°6-32h.	3	3,50	2,75	45x13x3,0	56,50	20x7	43,97	
UNC n°8-32h.	3	4,17	3,50	45x13x3,4	56,50	20x7	43,97	
UNC n°10-24h.	3	4,83	3,90	50x16x4,9	56,50	20x7	43,97	
UNC n°12-24h.	3	5,49	4,50	50x19x4,9	56,50	20x7	43,97	
UNC 1/4-20h.	3	6,35	5,10	50x19x4,9	48,42*	20x7	41,44*	
UNC 5/16-18h.	3	7,94	6,60	56x22x4,9	54,97*	25x9	42,52*	
UNC 3/8-16h.	3	9,52	8,00	70x24x5,5	62,54*	30x11	59,12*	
UNC 7/16-14h.	3	11,11	9,40	70x24x6,2	81,44	38x14	59,12	
UNC 1/2-13h.	3	12,70	10,75	75x29x7,0	93,70*	38x14	60,77*	
UNC 9/16-12h.	3	14,28	12,20	80x30x9,0	110,62	38x14	63,60	
UNC 5/8-11h.	3	15,87	13,50	80x32x9,0	152,56*	45x18	86,21*	
UNC 3/4-10h.	3	19,05	16,50	95x40x11,0	207,87*	45x18	86,21*	
UNC 7/8-9h.	3	22,22	19,50	100x40x14,5	255,89	55x22	120,36	
UNC 1"-8h.	3	25,40	22,25	110x50x14,5	345,54*	55x22	115,72*	
UNC 1.1/8-7h.	3	28,57	25,00	125x56x18,0	520,99	65x25	171,90	
UNC 1.1/4-7h.	3	31,75	28,00	125x56x18,0	655,77	65x25	171,90	
UNC 1.3/8-6h.	3	34,92	30,75	150x63x22,0	831,92	65x25	171,90	
UNC 1.1/2-6h.	3	38,10	34,00	150x63x24,0	1.021,43	75x30	268,02	
UNC 2"-4,5h.	3	50,80	45,00	180x75x32,0	2.200,08	90x36		

Icon	Pcs.	D1 mm	L1 mm	L2 x L3 mm	M0		C5	
					€	Ø x L3 mm	€	
UNF n°2-64h.	2	2,18	1,85	36x8x2,1	70,71			
UNF n°3-56h.	2	2,51	2,15	40x9x2,1	70,71			
UNF n°4-48h.	2	2,84	2,35	40x9x2,7	44,06	20x5	45,57	
UNF n°5-44h.	2	3,17	2,70	45x10x2,7	44,06	20x5	43,97	
UNF n°6-40h.	2	3,50	2,95	45x16x3,0	42,11	20x5	43,97	
UNF n°8-36h.	2	4,17	3,50	50x12x3,4	42,11	20x7	43,97	
UNF n°10-32h.	2	4,83	4,10	50x12x4,9	42,11	20x7	43,97	
UNF n°12-28h.	2	5,49	4,60	50x12x4,9	44,06	20x7	43,97	
UNF 1/4-28h.	2	6,35	5,50	50x14x4,9	32,14*	25x9	38,82*	
UNF 5/16-24h.	2	7,94	6,90	56x22x4,9	34,41*	25x9	43,33*	
UNF 3/8-24h.	2	9,52	8,50	63x20x5,5	39,73*	38x10	59,12*	
UNF 7/16-20h.	2	11,11	9,90	63x20x6,2	52,72	38x10	58,00	
UNF 1/2-20h.	2	12,70	11,50	70x22x7,0	53,94*	38x10	63,19*	
UNF 9/16-18h.	2	14,29	12,90	70x22x9,0	70,29	38x10	66,15	
UNF 5/8-18h.	2	15,87	14,50	70x22x9,0	90,80*	45x14	86,21*	
UNF 3/4-16h.	2	19,05	17,50	80x22x11,0	121,96*	45x14	86,21*	
UNF 7/8-14h.	2	22,22	20,40	80x22x14,5	156,74*	55x16	115,72*	
UNF 1"-12h.	2	25,40	23,25	90x22x16,0	207,83	55x16	115,72	
UNF 1"-14h.	2	25,40	23,60	90x22x14,5	230,23*	55x16	125,74*	
UNF 1.1/8-12h.	2	28,57	26,50	90x22x18,0	306,75	65x18	140,93	
UNF 1.1/4-12h.	2	31,75	29,50	90x22x20,0	374,63	65x18	178,78	
UNF 1.3/8-12h.	2	34,92	32,80	125x35x22,0	505,42	65x18	187,15	
UNF 1.1/2-12h.	2	38,10	36,00	125x40x22,0	638,51	75x20	268,02	
UNF 2"-12h.	2	50,80	48,38	140x40x29,0	1.579,94	90x22		

* Check the price of left hand sets of taps and dies available in page 188.

HSS HAND TAPS AND DIES



Threading tools
Green
Pink

Icon	Pcs.	D1 mm	L1 x L2 x mm	M0		C5		Icon	Pcs.	MOT		C5T		MOX		CSX	
				HSS	€	HSS	€			HSS	€	TiN	€	HSS	€	HSSCo	OX
G 1/8-28h.	2	9,73	8,80	63 x 20 x 5,5	35,93*	38 x 10	52,86*	G 1/8-28 h.	2	78,20	98,55	89,85	67,01				
G 1/4-19h.	2	13,16	11,80	70 x 22 x 9,0	50,64*	38 x 10	52,58*	G 1/4-19 h.	2	142,27	101,99	161,46	69,12				
G 3/8-19h.	2	16,66	15,25	70 x 22 x 9,0	63,57*	45 x 14	69,64*	G 3/8-19 h.	2	173,58	114,73	200,57	82,22				
G 1/2-14h.	2	20,95	19,00	80 x 22 x 12,0	89,16*	45 x 14	69,64*	G 1/2-14 h.	2	244,64	129,87	270,62	90,98				
G 5/8-14h.	2	22,91	21,00	80 x 22 x 14,5	114,08*	55 x 16	96,61*										
G 3/4-14h.	2	26,44	24,50	90 x 22 x 16,0	139,17*	55 x 16	125,76*	G 3/4-14 h.	2	320,95	211,59	388,44	155,18				
G 7/8-14h.	2	30,20	28,25	90 x 22 x 18,0	187,36	65 x 18	149,71										
G 1"-11h.	2	33,25	30,75	100 x 25 x 20,0	220,63*	65 x 18	151,16*	G 1" -11 h.	2	559,37	282,63	638,89	185,39				
G 1.1/8-11h.	2	37,90	35,50	125 x 40 x 22,0	352,09	75 x 20	213,34										
G 1.1/4-11h.	2	41,91	39,50	125 x 40 x 24,0	383,69*	75 x 20	209,42*										
G 1.3/8-11h.	2	44,32	42,00	125 x 40 x 29,0	521,14	90 x 22	328,17										
G 1.1/2-11h.	2	47,80	45,25	140 x 40 x 29,0	579,86	90 x 22	316,12										
G 1.3/4-11h.	2	53,75	51,25	140 x 40 x 32,0	964,01	105 x 22	328,17										
G 2"-11h.	2	59,61	57,00	160 x 40 x 35,0	1.071,90	105 x 22	394,95										
G 2.1/4-11h.	2	65,71	63,00	160 x 40 x 39,0	1.770,67	105 x 22											
G 2.1/2-11h.	2	75,18	72,50	160 x 40 x 39,0	2.661,51	120 x 22											
G 2.3/4-11h.	2	81,53	79,00	160 x 40 x 39,0	3.227,33	120 x 22											
G 3"-11h.	2	87,88	85,50	160 x 40 x 39,0	3.358,99	150 x 25											
G 4"-11h.	2	113,03	110,50	180 x 45 x 44,0	5.094,44	180 x 25											



Icon	Pcs.	D1 mm	L1 x L2 x mm	€	
UNF n°4-48-3B	2	2,84	2,35	40x9x2,7	56,12
UNF n°5-44-3B	2	3,17	2,70	45x10x2,7	56,12
UNF n°6-40-3B	2	3,50	2,95	45x16x3,0	52,94
UNF n°8-36-3B	2	4,17	3,50	50x12x3,4	52,94
UNF n°10-32-3B	2	4,83	4,10	50x12x4,9	52,94
UNF n°12-28-3B	2	5,49	4,60	50x12x4,9	56,12
UNF 1/4-28-3B	2	6,35	5,50	50x14x4,9	40,93
UNF 5/16-24-3B	2	7,94	6,90	56x22x4,9	43,82
UNF 3/8-24-3B	2	9,52	8,50	63x20x5,5	50,59
UNF 7/16-20-3B	2	11,11	9,90	63x20x6,2	67,16
UNF 1/2-20-3B	2	12,70	11,50	70x22x7,0	68,70

* Check the price of left hand sets of taps and dies available in page 188.

HSS HAND TAPS AND DIES

Threading tools

Pink

Green

BSW

Ref. M0

HSS

DIN 351

TOL 2 Class

Ref. C5

HSS

DIN 223

BSF

Ref. M0

HSS

DIN 5157

TOL ISO 228

Ref. C5

HSS

DIN 223



Icon	D1 mm	L1	L2	M0		C5	
				€	Ø x L3 mm	€	
W 1/16-60h.	3	1,59	1,15	32x8x2,1	60,71	16x5	81,70
W 3/32-48h.	3	2,38	1,80	40x9x2,1	44,39	20x5	42,16
W 1/8-40h.	3	3,17	2,55	40x14x2,7	31,88*	25x9	33,27*
W 5/32-32h.	3	3,97	3,10	45x17x3,4	32,21	25x9	33,94
W 3/16-24h.	3	4,76	3,60	50x19x4,9	31,88	25x9	33,27
W 7/32-24h.	3	5,55	4,40	50x19x4,9	52,44	25x9	43,46
W 1/4-20h.	3	6,35	5,10	50x20x4,9	35,91*	25x9	33,94*
W 5/16-18h.	3	7,94	6,50	56x20x4,9	43,86*	25x9	35,40*
W 3/8-16h.	3	9,52	7,90	63x22x5,5	48,19*	38x10	51,23*
W 7/16-14h.	3	11,11	9,25	70x22x6,2	64,69	38x10	51,30
W 1/2-12h.	3	12,70	10,50	75x25x7,0	69,42	38x14	50,34
W 9/16-12h.	3	14,29	12,00	80x26x9,0	94,44	38x14	61,48
W 5/8-11h.	3	15,87	13,40	80x27x9,0	108,60*	45x18	73,11*
W 11/16-11h.	3	17,46	15,25	95x32x11,0	255,93	45x18	120,43
W 3/4-10h.	3	19,05	16,50	95x32x11,0	154,60*	45x18	73,22*
W 7/8-9h.	3	22,22	19,25	100x32x14,5	211,14*	55x22	107,66*
W 1"-8h.	3	25,40	21,75	110x36x14,5	258,75*	55x22	108,64*
W 1.1/8-7h.	3	28,57	24,75	125x40x18,0	383,52	65x25	171,07
W 1.1/4-7h.	3	31,75	27,75	125x40x18,0	464,02	65x25	171,14
W 1.3/8-6h.	3	34,92	30,50	150x50x22,0	577,03	65x25	174,30
W 1.1/2-6h.	3	38,10	33,50	150x50x24,0	694,72	75x30	264,95
W 1.5/8-5h.	3	41,27	46,50	150x56x24,0	966,99	75x30	329,91
W 1.3/4-5h.	3	44,45	39,00	160x58x29,0	1.190,14	90x36	415,20
W 1.7/8-4,5h.	3	47,62	42,00	180x65x29,0	1.537,13	90x36	454,32
W 2"-4,5h.	3	50,80	44,50	180x65x32,0	1.613,72	90x36	476,13
W 2.1/4-4h.	3	57,15	50,00	200x85x35,0	2.673,86	105x36	
W 2.1/2-4h.	3	63,50	56,50	220x85x39,0	3.252,80	120x36	
W 2.3/4-3,5h.	3	69,85	62,00	250x90x44,0	4.644,61	120x36	
W 3"-3,5h.	3	76,20	68,00	250x90x44,0	5.373,30	140x36	

Icon	D1 mm	L1	L2	M0		C5	
				€	Ø x L3 mm	€	
BSF 3/16-32h.	2	4,76	4,0	50x19x4,9	119,98	20x7	43,78
BSF 1/4-26h.	2	6,35	5,2	50x20x4,9	48,80	20x7	48,48
BSF 5/16-22h.	2	7,94	6,6	56x20x4,9	56,90	25x9	49,03
BSF 3/8-20h.	2	9,52	8,1	63x22x5,5	65,85	30x11	94,18
BSF 7/16-18h.	2	11,11	9,5	70x22x6,2	79,02	30x11	93,31
BSF 1/2-16h.	2	12,70	11,0	75x25x7,0	89,40	38x10	81,43
BSF 9/16-16h.	2	14,29	12,5	80x26x9,0	107,16	38x10	85,93
BSF 5/8-14h.	2	15,88	14,0	80x26x9,0	140,23	45x14	133,96
BSF 3/4-12h.	2	19,05	16,5	95x33x11,0	214,34	45x14	135,20
BSF 7/8-11h.	2	22,23	19,5	100x33x14,5	255,83	55x22	181,31
BSF 1"-10h.	2	25,40	22,5	110x40x14,5	359,11	55x22	179,30
BSF 1.1/8-9h.	2	28,57	25,5	110x40x16,0	810,29		
BSF 1.1/4-9h.	2	31,75	28,5	125x46x18,0	925,10		
BSF 1.1/2-8h.	2	38,10	34,5	150x55x22,0	1.409,91		

BSW

INOX

TiN

Icon	D1 mm	L1	L2	M0T		C5T	
				€	Ø x L3 mm	€	
W 3/16-24 h.	3	50	19	4,90	60,87	25x9	60,84
W 1/4-20 h.	3	50	20	4,90	68,14	25x9	61,96
W 5/16-18 h.	3	56	20	4,90	74,66	25x9	64,41
W 3/8-16 h.	3	63	22	5,50	87,87	38x10	76,14
W 1/2-12 h.	3	75	25	7,00	124,00	38x14	102,29





* Check the price of left hand sets of taps and dies available in page 188.

HSS HAND TAPS AND DIES

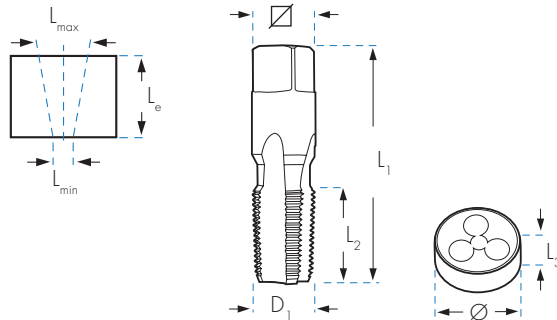

NPTF  AMERICAN dryseal taper pipe thread Ref. M0 **HSS** Ref. C5 **HSS** **DIN 223**

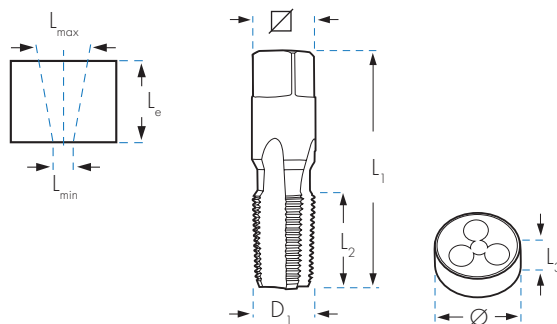

		D ₁ mm		L _{min} × L _{max} mm	L _e mm	L ₁ × L ₂ ×  mm	€	Ø × L ₃ mm	€
NPTF 1/8-27 h.	1	10,22	8,5	8,30 × 8,76	12,0	54 × 19 × 8,0	97,82	38 × 10	213,61
NPTF 1/4-18 h.	1	13,58	11,0	10,70 × 11,40	17,5	62 × 27 × 11,0	137,10	38 × 15	213,61
NPTF 3/8-18 h.	1	17,02	14,5	14,20 × 14,84	17,6	65 × 27 × 13,0	189,25	45 × 14	278,91
NPTF 1/2-14 h.	1	21,21	17,8	17,40 × 18,33	22,8	80 × 35 × 13,0	264,64	45 × 20	278,91
NPTF 3/4-14 h.	1	26,56	23,0	22,80 × 23,68	23,0	83 × 35 × 17,0	404,52	55 × 22	531,58
NPTF 1"-11,5 h.	1	33,19	29,0	28,60 × 29,72	27,4	110 × 38 × 20,0	538,83		

NPT  AMERICAN taper pipe thread (Briggs) Ref. M0 **HSS** Ref. C5 **HSS** **DIN 223**



		D ₁ mm			L _{min} × L _{max} mm	L _e mm	L ₁ × L ₂ ×  mm	€	Ø × L ₃ mm	€
NPT 1/16-27 h.	1	7,89	6,20	EMNPT1/16	6,00 × 6,38	12,0	54 × 18 × 6,0	37,14	25 × 9	122,79
NPT 1/8-27 h.	1	10,24	8,50	EMNPT1/8	8,30 × 8,73	12,0	65 × 19 × 5,5	37,14	30 × 11	90,79
NPT 1/4-18 h.	1	13,62	11,00	EMNPT1/4	10,70 × 11,35	17,5	62 × 27 × 11,0	52,11	38 × 14	90,79
NPT 3/8-18 h.	1	17,05	14,50	EMNPT3/8	14,20 × 14,80	17,6	65 × 27 × 13,0	71,91	45 × 18	118,52
NPT 1/2-14 h.	1	21,23	17,80	EMNPT1/2	17,40 × 18,32	22,8	80 × 35 × 13,0	100,55	45 × 18	118,52
NPT 3/4-14 h.	1	26,57	23,00	-	22,80 × 23,66	23,0	83 × 35 × 17,0	153,72	55 × 22	216,82
NPT 1"-11,5 h.	1	33,23	29,00	-	28,60 × 29,69	27,4	95 × 44 × 21,0	171,20	65 × 25	260,65
NPT 1.1/4-11,5 h.	1	41,98	37,50	-	37,40 × 38,45	28,1	125 × 33 × 24,0	280,70	75 × 26	323,90
NPT 1.1/2-11,5 h.	1	48,05	44,00	-	43,40 × 44,52	28,4	140 × 33 × 29,0	426,53	90 × 27	451,90
NPT 2"-11,5 h.	1	60,09	56,00	-	55,50 × 56,56	28,4	160 × 33 × 35,0	665,90	105 × 36	629,16
NPT 2.1/2"-8h.	1	73,03	67,00	-	68,68 × 69,08	28,9	200 × 45 × 39,0	813,66		
NPT 3"-8h.	1	88,90	82,00	-	84,45 × 84,86	30,5	220 × 48 × 39,0	1.143,70		

* Also available prior reamer on page 137

HSS HAND TAPS AND DIES

PG

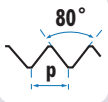

Ref. M0

HSS

DIN
40430

Ref. C5

HSS

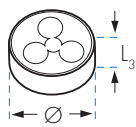
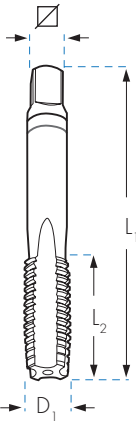
DIN
223

					M0		C5	
		D ₁ mm		L ₁ x L ₂ x	€	Ø x L ₃ mm	€	
Pg 7	20h.	1	12,5	11,50	70x20x70	35,61	38x10	65,48
Pg 9	18h.	1	15,2	14,00	70x20x9,0	45,27	38x10	65,48
Pg 11	18h.	1	18,6	17,25	80x22x11,0	62,86	45x14	81,98
Pg 13,5	18h.	1	20,4	19,00	80x22x12,0	68,93	45x14	81,98
Pg 16	18h.	1	22,5	21,25	80x22x14,5	82,79	55x16	105,76
Pg 21	16h.	1	28,3	27,00	90x22x18,0	121,74	65x18	150,33
Pg 29	16h.	1	37,0	35,50	100x25x22,0	241,73	65x18	150,33
Pg 36	16h.	1	47,0	45,50	140x32x29,0	396,70	90x22	385,31
Pg 42	16h.	1	54,0	52,50	140x36x32,0	471,11	105x22	385,31
Pg 48	16h.	1	59,3	58,00	160x36x35,0	594,16	105x22	510,96

NPSF

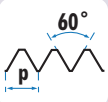
AMERICAN dryseal
straight pipe thread

Ref. M0

HSS

Ref. C5

HSS

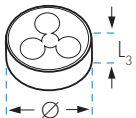
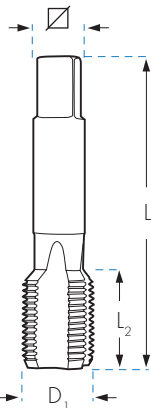
DIN
223

					M0		C5	
		D ₁ mm		L ₁ x L ₂ x	€	Ø x L ₃ mm	€	
NPSF 1/8-27 h.	1	10,05	8,75	63x18x5,5	147,30	38x10	256,60	
NPSF 1/4-18 h.	1	13,35	11,30	70x20x9,0	212,85	38x10	256,60	
NPSF 3/8-18 h.	1	16,78	14,70	70x20x9,0	294,42	45x14	326,43	
NPSF 1/2-14 h.	1	20,87	18,20	80x22x12,0	384,88	45x14	326,43	
NPSF 3/4-14 h.	1	26,23	23,50	90x22x16,0	585,61	55x16	705,59	

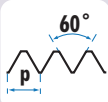
NPS
(M)AMERICAN
straight pipe thread

Ref. M0

HSS

Ref. C5

HSS

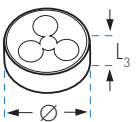
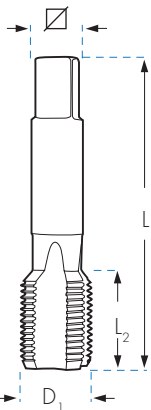

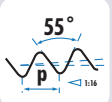

DIN
223

					M0		C5	
		D ₁ mm		L ₁ x L ₂ x	€	Ø x L ₃ mm	€	
NPS 1/8-27 h.	1	10,20	8,9	63x18x5,5	122,05	38x10	213,78	
NPS 1/4-18 h.	1	13,60	11,7	70x20x9,0	97,13	38x10	213,78	
NPS 3/8-18 h.	1	17,00	15,0	70x20x9,0	134,34	45x14	272,01	
NPS 1/2-14 h.	1	21,20	18,6	80x22x12,0	175,59	45x14	272,01	
NPS 3/4-14 h.	1	26,55	24,0	90x22x16,0	254,99	55x16	538,85	
NPS 1"-11,5 h.	1	33,20	30,0	100x25x20,0	356,54	65x18	543,05	

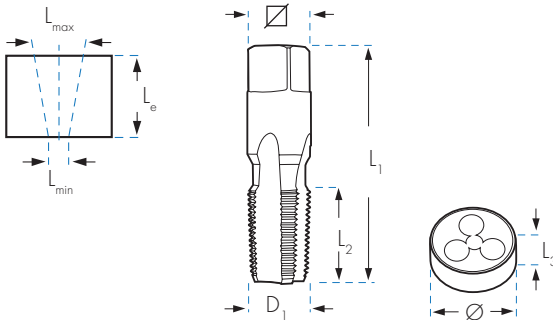
HSS HAND TAPS AND DIES





BSPT  Ref. M0 **HSS** **DIN 5157** Ref. C5 **HSS** **DIN 223**

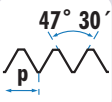

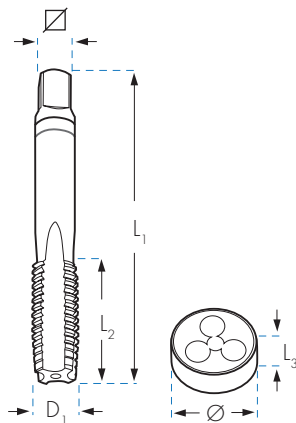
			D ₁ mm		L _{min} x L _{max} mm	L _e mm	L ₁ x L ₂ x  mm	€	Ø x L ₃ mm	€
BSPT 1/8-28 h.	1	9,73	8,30	8,00 x 8,50	10,1	65 x 19 x 5,5	33,25	30 x 11	99,12	
BSPT 1/4-19 h.	1	13,16	11,00	10,70 x 11,35	15,0	70 x 25 x 9,0	46,85	38 x 14	99,12	
BSPT 3/8-19 h.	1	16,66	14,50	14,15 x 14,25	15,4	70 x 25 x 9,0	65,06	45 x 16	129,09	
BSPT 1/2-14 h.	1	20,95	18,10	17,60 x 18,50	20,5	80 x 31 x 12,0	91,10	55 x 22	129,09	
BSPT 5/8-14 h.	1	22,91	20,00	19,50 x 20,40	22,4	80 x 36 x 14,5	159,76	55 x 19	269,37	
BSPT 3/4-14 h.	1	26,44	23,50	23,00 x 24,00	21,8	85 x 33 x 16,0	148,65	55 x 22	243,78	
BSPT 7/8-14 h.	1	30,20	27,25	26,65 x 28,75	24,0	100 x 36 x 18,0	281,71	65 x 22	351,92	
BSPT 1"-11 h.	1	33,25	29,60	29,00 x 30,20	26,0	110 x 38 x 20,0	235,42	65 x 25	281,51	

BA  Ref. M0 **HSS** **DIN 352** Ref. C5 **HSS** **DIN 223**



			D ₁ mm		L ₁ x L ₂ x  mm	€	Ø x L ₃ mm	€
BA-0	1,00	3	6,0	5,1	50 x 18 x 4,9	207,17	20 x 5	161,97
BA-1	0,90	3	5,3	4,5	50 x 18 x 4,9	207,17	20 x 5	161,97
BA-2	0,81	3	4,7	4,0	50 x 17 x 4,9	207,17	20 x 5	161,97
BA-3	0,73	3	4,1	3,4	45 x 14 x 3,4	222,63	20 x 5	161,97
BA-4	0,66	3	3,6	3,0	45 x 14 x 3,0	222,63	20 x 5	161,97
BA-5	0,59	3	3,2	2,6	45 x 14 x 3,0	266,01	20 x 5	161,97
BA-6	0,53	3	2,8	2,3	40 x 12 x 2,7	266,01	20 x 5	161,97
BA-7	0,48	3	2,5	2,0	40 x 10 x 2,1	292,46	20 x 5	161,97
BA-8	0,43	3	2,2	1,8	36 x 10 x 2,1	292,46	20 x 5	161,97

HSS HAND TAPS AND DIES

Threading tools

Green

UNx8

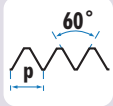
AMERICAN
thread pitch

Ref. M0

HSS

DIN
2181TOL
2B

Ref. C5

HSS

DIN
223TOL
2a

		D1 mm	Ø	L1 x L2 x mm	M0		C5	
					€	Ø x L3 mm	€	
UN 1"1/8-8h.	2	28,57	25,40	138x65x170	390,67	65x25	427,89	
UN 1"1/4-8h.	2	31,75	28,50	146x65x19,5	506,63	65x25	427,89	
UN 1"3/8-8h.	2	34,92	31,75	154x76x21,0	630,11	65x25	426,01	
UN 1"1/2-8h.	2	38,10	35,00	162x76x23,5	721,11	75x30	482,28	
UN 1"5/8-8h.	2	41,27	38,10	170x80x25,0	896,53	75x30	504,81	
UN 1"3/4-8h.	2	44,45	41,25	178x81x27,0	1.117,32	90x36	673,10	
UN 1"7/8-8h.	2	47,62	44,45	186x90x29,0	1.393,92	90x36	720,20	
UN 2"-8h.	2	50,80	47,63	194x90x31,5	1.325,21	90x36	729,18	
UN 2"1/4-8h.	2	57,15	54,00	208x90x36,0				
UN 2"1/2-8h.	2	63,50	60,35	220x100x36,0				
UN 2"3/4-8h.	2	69,85	66,70	234x104x39,0				
UN 3"-8h.	2	76,20	73,05	248x115x49,0				

UNEF

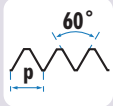
AMERICAN
extra fine thread

Ref. M0

HSS

DIN
2181TOL
2B

Ref. C5

HSS

DIN
223TOL
2a

		D1 mm	Ø	L1 x L2 x mm	M0		C5	
					€	Ø x L3 mm	€	
UNEF 1/4-32h.	2	6,35	5,55	65x28x4,9	105,00	20x7	106,61	
UNEF 5/16-32h.	2	7,94	7,15	70x30x6,0	117,31	25x9	106,61	
UNEF 3/8-32h.	2	9,52	8,70	75x33x7,0	134,25	30x11	165,54	
UNEF 7/16-28h.	2	11,11	10,20	81x38x6,0	170,89	30x11	165,54	
UNEF 1/2-28h.	2	12,70	11,80	86x44x7,0	193,10	38x10	165,54	
UNEF 9/16-24h.	2	14,29	13,20	92x44x8,0	157,85	38x10	165,54	
UNEF 5/8-24h.	2	15,87	14,80	93x47x9,0	162,59	45x14	265,34	
UNEF 3/4-20h.	2	19,05	17,80	108x52x11,0	178,94	45x14	265,34	
UNEF 7/8-20h.	2	22,22	20,95	120x58x13,0	271,56	55x16	315,63	
UNEF 1"-20h.	2	25,40	24,20	130x65x15,0	279,32	55x16	324,28	

HAND TAPS, SPECIAL APPLICATIONS

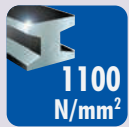

Ref. M0MD

HSSCo
5%

DIN
352

OX



HARD MATERIALS (< 1100 N/mm²=40Hrc)

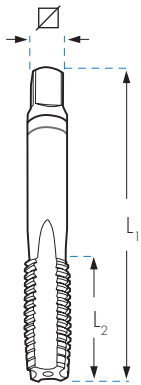

				M0MD
			$L_1 \times L_2 \times \nabla$ mm	€
M 3 x 0,50	3	2,50	40 x 11 x 2,7	38,32
M 4 x 0,70	3	3,30	45 x 13 x 3,4	38,32
M 5 x 0,80	3	4,20	50 x 17 x 4,9	39,56
M 6 x 1,00	3	5,00	50 x 19 x 4,9	40,73
M 8 x 1,25	3	6,80	56 x 20 x 4,9	46,31
M 10 x 1,50	3	8,50	70 x 22 x 5,5	59,44
M 12 x 1,75	3	10,20	75 x 24 x 7,0	85,11
M 14 x 2,00	3	12,00	80 x 26 x 9,0	100,74
M 16 x 2,00	3	14,00	80 x 27 x 9,0	133,85
M 18 x 2,50	3	15,50	95 x 30 x 11,0	205,86
M 20 x 2,50	3	17,50	95 x 32 x 12,0	228,55

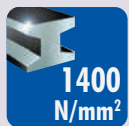

Ref. M0C

HSS
PM

TiAlSiN



VERY HARD MATERIALS (< 1400 N/mm²=44Hrc)

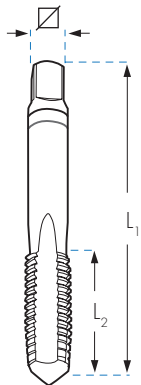

				M0C
			$L_1 \times L_2 \times \nabla$ mm	€
M 3 x 0,50	3	2,50	40 x 11 x 2,7	95,43
M 4 x 0,70	3	3,30	45 x 13 x 3,4	102,97
M 5 x 0,80	3	4,20	50 x 17 x 4,9	104,25
M 6 x 1,00	3	5,00	50 x 19 x 4,9	104,25
M 8 x 1,25	3	6,80	56 x 20 x 4,9	117,51
M 10 x 1,50	3	8,50	70 x 22 x 5,5	145,25
M 12 x 1,75	3	10,20	75 x 24 x 7,0	176,57
M 14 x 2,00	3	12,00	80 x 26 x 9,0	216,66
M 16 x 2,00	3	14,00	80 x 27 x 9,0	259,60
M 18 x 2,50	3	15,50	95 x 30 x 11,0	359,92
M 20 x 2,50	3	17,50	95 x 32 x 12,0	396,13

Al

Ref. M0AL

HSS

BRIGHT



SPECIAL FOR ALUMINIUM

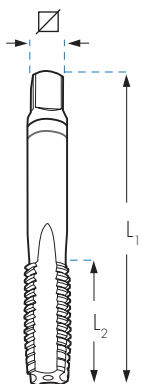

				M0AL
			$L_1 \times L_2 \times \nabla$ mm	€
M 3 x 0,50	3	2,50	40 x 11 x 2,7	29,84
M 4 x 0,70	3	3,30	45 x 13 x 3,4	28,97
M 5 x 0,80	3	4,20	50 x 17 x 4,9	30,70
M 6 x 1,00	3	5,00	50 x 19 x 4,9	30,70
M 8 x 1,25	3	6,80	56 x 20 x 4,9	37,68
M 10 x 1,50	3	8,50	70 x 22 x 5,5	46,01
M 12 x 1,75	3	10,20	75 x 24 x 7,0	64,78
M 14 x 2,00	3	12,00	80 x 26 x 9,0	74,44
M 16 x 2,00	3	14,00	80 x 27 x 9,0	105,66
M 18 x 2,50	3	15,50	95 x 30 x 11,0	140,04
M 20 x 2,50	3	17,50	95 x 32 x 12,0	157,87

HAND TAPS AND DIES FOR STAINLESS STEEL

M

INOX

Ref. MOT
Ref. MOXDIN
352TOL
6H

TiN

Ref. CST
Ref. CSXDIN
223TOL
6g

OX

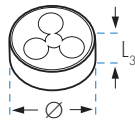
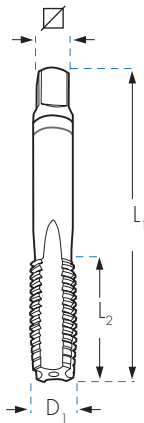

			L ₁ × L ₂ × mm	MOT	CST	MOX	CSX	Ø × L ₃ mm
				HSS	HSS	HSSCo	HSSCo	
				TiN	TiN	OX	OX	
				€	€	€	€	
M 3 x 0,50	3	40 x 11 x 2,70		42,73	62,83	39,41	34,13	20 x 5
M 4 x 0,70	3	45 x 13 x 3,40		44,89	62,83	39,41	34,13	20 x 5
M 5 x 0,80	3	50 x 16 x 4,90		47,63	62,83	41,03	35,78	20 x 7
M 6 x 1,00	3	50 x 19 x 4,90		47,63	62,83	40,90	36,28	20 x 7
M 8 x 1,00	2	50 x 19 x 4,90		41,87				
M 8 x 1,25	3	56 x 22 x 4,90		54,93	64,41	47,60	39,35	25 x 9
M 10 x 1,00	2	63 x 18 x 5,50		48,31				
M 10 x 1,50	3	70 x 24 x 5,50		73,16	84,56	61,24	49,93	30 x 11
M 12 x 1,50	2	70 x 20 x 7,00		61,51				
M 12 x 1,75	3	75 x 29 x 7,00		84,88	93,76	87,70	52,75	38 x 14
M 14 x 1,50	2	70 x 20 x 9,00		73,86				
M 14 x 2,00	3	80 x 30 x 9,00		102,65	93,76	97,12	52,75	38 x 14
M 16 x 2,00	3	80 x 32 x 9,00		128,91	115,54	133,10	70,82	45 x 18
M 18 x 2,50	3	95 x 40 x 11,00		159,80		181,78		
M 20 x 2,50	3	95 x 40 x 12,00		165,71		201,77		
M 22 x 2,50	3	100 x 40 x 14,50		209,62				
M 24 x 3,00	3	110 x 50 x 14,50		252,59				

M

HSS HEXAGONAL DIES

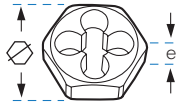

M HSS DIN 382

C5HM			C5HM		
		€			€
M 3 x 0,35	18 x 5	40,65	M 16 x 2,00	41 x 18	111,70
M 3 x 0,50	19 x 5	40,65	M 18 x 1,00	41 x 14	111,70
M 3,5 x 0,60	18 x 5	40,65	M 18 x 1,50	41 x 14	111,70
M 4 x 0,50	18 x 5	40,65	M 18 x 2,50	41 x 18	111,70
M 4 x 0,70	19 x 5	40,65	M 20 x 1,00	41 x 14	111,70
M 5 x 0,50	18 x 5	40,65	M 20 x 1,50	41 x 14	111,70
M 5 x 0,75	18 x 5	40,65	M 20 x 2,00	41 x 18	111,70
M 5 x 0,80	19 x 7	40,65	M 20 x 2,50	41 x 18	111,70
M 6 x 0,75	18 x 7	40,65	M 22 x 1,00	50 x 16	141,23
M 6 x 1,00	19 x 7	40,65	M 22 x 1,50	50 x 16	141,23
M 7 x 0,75	21 x 9	43,21	M 22 x 2,00	50 x 16	141,23
M 7 x 1,00	21 x 9	43,21	M 22 x 2,50	50 x 16	141,23
M 8 x 0,75	21 x 9	43,21	M 24 x 1,00	50 x 16	172,01
M 8 x 1,00	21 x 9	43,21	M 24 x 1,50	50 x 16	172,01
M 8 x 1,25	22 x 9	43,21	M 24 x 2,00	50 x 16	172,01
M 9 x 0,75	21 x 9	50,86	M 24 x 3,00	50 x 22	141,23
M 9 x 1,00	21 x 9	50,86	M 27 x 1,50	60 x 18	190,96
M 9 x 1,25	22 x 9	50,86	M 27 x 2,00	60 x 18	190,96
M 10 x 1,00	27 x 11	50,86	M 27 x 3,00	60 x 25	159,13
M 10 x 1,25	27 x 11	50,86	M 30 x 1,00	60 x 18	190,96
M 10 x 1,50	27 x 11	50,86	M 30 x 1,50	60 x 18	190,96
M 11 x 1,00	27 x 11	84,75	M 30 x 2,00	60 x 18	190,96
M 11 x 1,50	27 x 11	84,75	M 30 x 3,00	60 x 18	190,96
M 12 x 1,25	36 x 10	84,75	M 30 x 3,50	60 x 25	159,13
M 12 x 1,50	36 x 10	84,75	M 33 x 1,50	60 x 18	213,82
M 12 x 1,75	36 x 10	71,20	M 33 x 2,00	60 x 18	213,82
M 14 x 1,25	36 x 14	96,30	M 33 x 3,50	60 x 25	178,19
M 14 x 1,50	36 x 10	96,30	M 35 x 1,50	60 x 18	220,43
M 14 x 2,00	36 x 10	71,20	M 36 x 1,50	60 x 18	220,43
M 15 x 1,00	36 x 14	111,70	M 36 x 2,00	60 x 18	220,43
M 15 x 1,50	41 x 14	111,70	M 36 x 3,00	60 x 18	220,43
M 16 x 1,00	41 x 14	111,70	M 36 x 4,00	60 x 25	183,69
M 16 x 1,50	41 x 14	111,70			

BSP (GAS) HSS DIN 382

C5HG		
		€
G 1/8 x 28h.	27 x 11	89,51
G 1/4 x 19h.	36 x 10	89,51
G 3/8 x 19h.	41 x 14	111,94
G 1/2 x 14h.	41 x 14	111,94
G 5/8 x 14h.	50 x 16	263,56
G 3/4 x 14h.	50 x 16	263,56
G 7/8 x 14h.	60 x 18	265,90
G 1" x 11h.	60 x 18	265,90
G1.1/4 x 11h.	70 x 20	354,54
G1.1/2 x 11h.	85 x 22	598,13
G 2" x 11h.	100 x 22	900,05

UNC HSS DIN 382

C5HNC		
		€
UNC 1/4-20h	18 x 7	37,07
UNC 5/16-18h	21 x 9	46,13
UNC 3/8-16h	27 x 11	55,68
UNC 7/16-14h	27 x 11	82,17
UNC 1/2-13h	36 x 14	82,48
UNC 9/16-12h	36 x 14	98,56
UNC 5/8-11h	41 x 18	76,36
UNC 3/4-10h	41 x 18	121,47
UNC 7/8-9h	50 x 22	172,38
UNC 1"-8h	50 x 22	172,38
UNC 1.1/8-7h	60 x 25	227,91
UNC 1.1/4-7h	60 x 25	227,91

UNF HSS DIN 382

C5HNF		
		€
UNF 1/4-28h.	18 x 7	39,29
UNF 5/16-24h.	21 x 9	49,13
UNF 3/8-24h.	27 x 11	59,11
UNF 7/16-20h.	27 x 11	87,09
UNF 1/2-20h.	36 x 10	88,43
UNF 9/16-18h.	36 x 10	98,56
UNF 5/8-18h.	41 x 14	122,96
UNF 3/4-16h.	41 x 14	128,77
UNF 7/8-14h.	50 x 16	162,86
UNF 1"-12h.	50 x 16	170,72
UNS 1"-14h.	50 x 16	170,72
UNF 1.1/8-12h.	60 x 18	227,91
UNF 1.1/4-12h.	60 x 18	227,91

BSW HSS DIN 382

C5HW			C5HW		
		€			€
BSW 1/8 x 40h.	19 x 5	50,86	BSW 9/16 x 12h.	36 x 14	76,30
BSW 3/16 x 24h.	19 x 7	50,86	BSW 5/8 x 11h.	41 x 18	112,75
BSW 1/4 x 20h.	19 x 7	50,86	BSW 3/4 x 10h.	41 x 18	112,75
BSW 5/16 x 18h.	22 x 9	53,39	BSW 7/8 x 9h.	50 x 22	165,25
BSW 3/8 x 16h.	27 x 11	63,56	BSW 1" x 8h.	50 x 22	165,25
BSW 7/16 x 14h.	27 x 11	63,56	BSW 1.1/8 x 7h.	60 x 25	284,83
BSW 1/2 x 12h.	36 x 14	76,30			

Threading tools
Pink

SET OF LEFT TURNING HAND TAPS AND DIES

M
MF

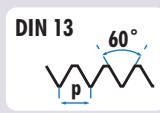

DIN 13
60°
P

Ref. MOI

HSS
DIN 352
DIN 2181
TOL 6H

Ref. CSI

HSS
DIN 223
TOL 6g

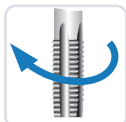

For hard materials up to 38 HRC



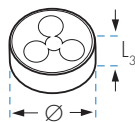
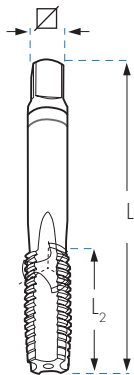

LEFT





UNC

		MOI				CSI	
	Pcs.	D1 mm		L1 x L2 x mm	€	Ø x L3 mm	€
UNC 1/4-20h.	3	6,35	5,10	50x19x4,9	96,84	20x7	82,87
UNC 5/16-18h.	3	7,94	6,60	56x22x4,9	109,94	25x9	85,03
UNC 3/8-16h.	3	9,52	8,00	70x24x5,5	125,08	30x11	118,23
UNC 1/2-13h.	3	12,70	10,75	75x29x7,0	187,41	38x14	121,54
UNC 5/8-11h.	3	15,87	13,50	80x32x9,0	305,11	45x18	172,42
UNC 3/4-10h.	3	19,05	16,50	95x40x11,0	415,73	45x18	172,42
UNC 1"-8h.	3	25,40	22,25	110x50x14,5	691,08	55x22	231,44



UNF



		MOI				CSI	
	Pcs.	D1 mm		L1 x L2 x mm	€	Ø x L3 mm	€
UNF 1/4-28h.	2	6,35	5,50	50x14x4,9	64,28	25x9	77,63
UNF 5/16-24h.	2	7,94	6,90	56x22x4,9	68,82	25x9	86,67
UNF 3/8-24h.	2	9,52	8,50	63x20x5,5	79,46	38x10	118,23
UNF 1/2-20h.	2	12,70	11,50	70x22x7,0	107,89	38x10	126,37
UNF 5/8-18h.	2	15,87	14,50	70x22x9,0	181,60	45x14	172,42
UNF 3/4-16h.	2	19,05	17,50	80x22x11,0	243,93	45x14	172,42
UNS 1"-14h.	2	25,40	23,60	90x22x14,5	460,46	55x16	251,48

BSP (GAS)

		MOI				CSI	
	Pcs.	D1 mm		L1 x L2 x mm	€	Ø x L3 mm	€
G 1/8-28h.	2	9,73	8,80	63 x 20 x 5,5	71,87	38x10	105,72
G 1/4-19h.	2	13,16	11,80	70 x 22 x 9,0	101,27	38x10	105,15
G 3/8-19h.	2	16,66	15,25	70 x 22 x 9,0	127,14	45x14	139,28
G 1/2-14h.	2	20,95	19,00	80 x 22 x 12,0	178,31	45x14	139,28
G 5/8-14h.	2	22,91	21,00	80 x 22 x 14,5	228,15	55x16	193,22
G 3/4-14h.	2	26,44	24,50	90 x 22 x 16,0	278,33	55x16	251,52
G 1"-11h.	2	33,25	30,75	100 x 25 x 20,0	441,26	65x18	302,31
G 1.1/4-11h.	2	41,91	39,50	125 x 40 x 24,0	767,38	75x20	418,85

BSW

		MOI				CSI	
	Pcs.	D1 mm		L1 x L2 x mm	€	Ø x L3 mm	€
W 1/8-40h.	3	3,17	2,55	40x14x2,7	63,77	25x9	66,55
W 1/4-20h.	3	6,35	5,10	50x20x4,9	71,83	25x9	67,88
W 5/16-18h.	3	7,94	6,50	56x20x4,9	87,73	25x9	70,81
W 3/8-16h.	3	9,52	7,90	63x22x5,5	96,38	38x10	102,46
W 5/8-11h.	3	15,87	13,40	80x27x9,0	217,19	45x18	146,22
W 3/4-10h.	3	19,05	16,50	95x32x11,0	309,20	45x18	146,45
W 7/8-9h.	3	22,22	19,25	100x32x14,5	422,28	55x22	215,33
W 1"-8h.	3	25,40	21,75	110x36x14,5	517,49	55x22	217,28

		MOI				CSI	
	Pcs.	D1 mm		L1 x L2 x mm	€	Ø x L3 mm	€
M 2x0,40	3	1,60	36x9,0x2,1	78,65	16x5	64,96	
M 3x0,50	3	2,50	40x11,0x2,7	44,16	25x9	59,08	
M 4x0,70	3	3,30	45x13,0x3,4	44,12	25x9	59,38	
M 5x0,80	3	4,20	50x16,0x4,9	47,17	25x9	59,04	
M 6x1,00	3	5,00	50x19x4,9	47,17	25x9	59,08	
M 7x1,00	3	6,00	50x19x4,9	57,45	25x9	62,01	
M 8x1,00	2	7,00	56x18x4,9	53,00	25x9	68,54	
M 8x1,25	3	6,80	56x22x4,9	57,41	25x9	62,69	
M 9x1,25	3	7,80	63x22x5,5	94,04	25x9	72,86	
M 10x1,50	3	8,50	70x24x5,5	70,79	38x10	83,91	
M 12x1,50	2	10,50	70x20x7,0	85,50	38x10	105,15	
M 12x1,75	3	10,20	75x29x7,0	99,58	38x14	91,16	
M 14x1,25	2	12,80	70x20x9,0	122,51	38x10	136,40	
M 14x2,00	3	12,00	80x30x9,0	110,17	38x14	90,27	
M 16x1,50	2	14,50	70x20x9,0	118,55	45x14	130,61	
M 16x2,00	3	14,00	80x32x9,0	157,62	45x18	122,39	
M 18x2,00	2	16,00	80x22x11,0	249,31	45x14	176,77	
M 18x2,50	3	15,50	95x40x11,0	208,02	45x18	122,43	
M 20x2,00	2	18,00	80x22x12,0	264,09	45x14	175,83	
M 20x2,50	3	17,50	95x40x12,0	233,36	45x18	120,52	
M 22x2,00	2	20,00	80x22x14,5	343,19	55x16	226,56	
M 22x2,50	3	19,50	100x40x14,5	310,83	55x22	181,09	
M 24x2,00	2	22,00	90x22x14,5	409,22	55x16	230,87	
M 24x3,00	3	21,00	110x50x14,5	370,76	55x22	181,09	
M 27x2,00	2	25,00	90x22x16,0	567,14	65x18	341,19	
M 27x3,00	3	24,00	110x50x16,0	468,84	65x25	274,71	
M 30x3,00	2	27,00	125x56x18,0	601,23	65x25	387,26	
M 30x3,50	3	26,50	125x50x18,0	603,20	65x25	275,41	
M 33x2,00	2	31,00	100x25x20,0	857,69	65x18	478,36	
M 33x3,50	3	29,50	125x50x20,0	757,43	65x25	280,69	
M 36x3,00	2	33,00	125x33x22,0	1.384,72	65x25	330,06	
M 36x4,00	3	32,00	150x53x22,0	975,16	65x25	286,16	
M 39x3,00	2	36,00	125x33x24,0	1.197,21	75x30	517,07	
M 39x4,00	3	35,00	150x53x24,0	1.091,14	75x30	435,26	

Other dimensions are available on request

METRIC THREAD LEFT AND RIGHT TURNING TAP NUMBER 3

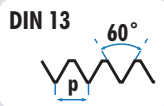

HSS

DIN 352

TOL 6H

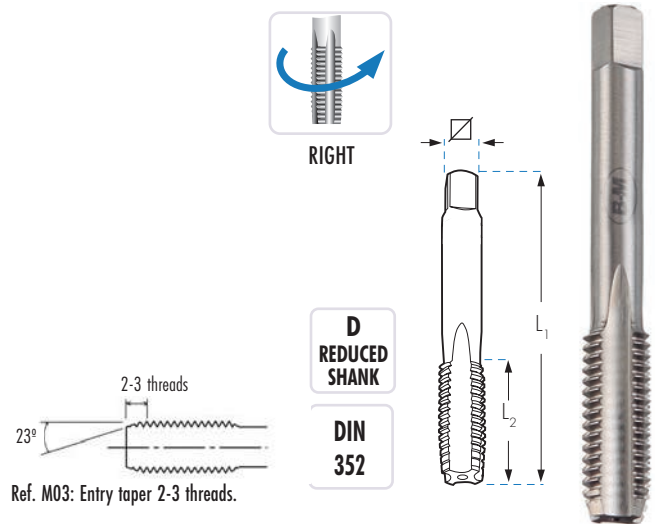
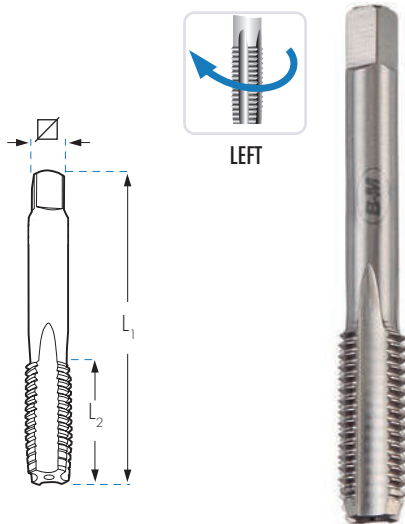

		M03I	
		L ₁ x L ₂ x D ₂ x	€
mm			
M 3x0,50	2,50	D 40 x 11 x 3,50 x 2,70	14,72
M 4x0,70	3,30	D 45 x 13 x 4,50 x 3,40	14,71
M 5x0,80	4,20	D 50 x 16 x 6,00 x 4,90	15,72
M 6x1,00	5,00	D 50 x 19 x 6,00 x 4,90	15,72
M 7x1,00	6,00	D 50 x 19 x 6,00 x 4,90	19,15
M 8x1,25	6,75	D 56 x 22 x 6,00 x 4,90	19,14
M 10x1,50	8,50	D 70 x 24 x 7,00 x 5,50	23,60
M 12x1,75	10,20	D 75 x 29 x 9,00 x 7,00	33,19
M 14x2,00	12,00	D 80 x 30 x 11,00 x 9,00	36,72
M 16x2,00	14,00	D 80 x 32 x 12,00 x 9,00	52,54
M 18x2,50	15,50	D 95 x 40 x 14,00 x 11,00	69,34
M 20x2,50	17,50	D 95 x 40 x 16,00 x 12,00	77,79

Other dimensions are available on request

		M03	
		L ₁ x L ₂ x D ₂ x	€
mm			
M 3x0,50	2,50	D 40 x 11 x 3,50 x 2,70	7,36
M 4x0,70	3,30	D 45 x 13 x 4,50 x 3,40	7,35
M 5x0,80	4,20	D 50 x 16 x 6,00 x 4,90	7,86
M 6x1,00	5,00	D 50 x 19 x 6,00 x 4,90	7,86
M 7x1,00	6,00	D 50 x 19 x 6,00 x 4,90	9,58
M 8x1,25	6,75	D 56 x 22 x 6,00 x 4,90	9,57
M 9x1,25	7,75	D 63 x 18 x 7,00 x 5,50	15,67
M 10x1,00	9,00	D 63 x 18 x 7,00 x 5,50	14,19
M 10x1,25	8,80	D 70 x 24 x 7,00 x 5,50	14,38
M 10x1,50	8,50	D 70 x 24 x 7,00 x 5,50	11,80
M 12x1,00	11,00	D 70 x 20 x 9,00 x 7,00	25,16
M 12x1,25	10,75	D 70 x 20 x 9,00 x 7,00	25,08
M 12x1,50	10,50	D 70 x 20 x 9,00 x 7,00	21,37
M 12x1,75	10,20	D 75 x 29 x 9,00 x 7,00	16,60
M 14x1,00	13,00	D 70 x 20 x 11,00 x 9,00	39,21
M 14x1,25	12,80	D 70 x 20 x 11,00 x 9,00	30,63
M 14x1,50	12,50	D 70 x 20 x 11,00 x 9,00	23,82
M 14x2,00	12,00	D 80 x 30 x 11,00 x 9,00	18,36
M 16x1,00	15,00	D 70 x 20 x 12,00 x 9,00	52,02
M 16x1,25	14,75	D 70 x 20 x 12,00 x 9,00	54,75
M 16x1,50	14,50	D 70 x 20 x 12,00 x 9,00	29,64
M 16x2,00	14,00	D 80 x 32 x 12,00 x 9,00	26,27
M 18x1,50	16,50	D 80 x 22 x 14,00 x 11,00	39,05
M 18x2,50	15,50	D 95 x 40 x 14,00 x 11,00	34,67
M 20x1,50	18,50	D 80 x 22 x 16,00 x 12,00	48,90
M 20x2,50	17,50	D 95 x 40 x 16,00 x 12,00	38,89
M 22x2,50	19,50	D 100 x 40 x 18,00 x 14,50	51,81
M 24x3,00	21,00	D 110 x 50 x 18,00 x 14,50	61,79
M 27x3,00	24,00	D 110 x 50 x 20,00 x 16,00	78,14
M 30x3,50	26,50	D 125 x 50 x 22,00 x 18,00	100,53

THREAD PITCH GAUGES



	THREAD TYPE	THREAD RANGE		GAM
		Metric	Empire	€
GAM	Metric	0,25 - 2,5		11,91
GAMW	Metric / Empire	0,25 - 6,0	62h - 4h	21,58

SET OF GUIDES FOR DIES M3-M12



CG5
M3-M12
14,42 €

TAP EXTENSION

DIN
377

DIN 10

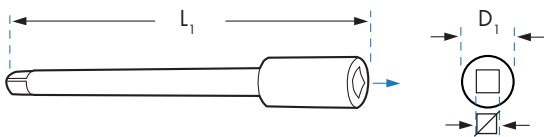

Same square dimensions in both male and female areas.

	$\square \times L_1$ mm	D_1	AL €
AL21	2,1 x 60	6,0	8,63
AL24	2,4 x 70	6,0	8,63
AL27	2,7 x 80	7,0	8,63
AL30	3,0 x 90	7,0	8,63
AL34	3,4 x 95	8,0	9,36
AL38	3,8 x 95	9,0	9,77
AL43	4,3 x 105	10,0	10,88
AL49	4,9 x 110	11,0	10,89
AL55	5,5 x 115	12,0	10,96
AL62	6,2 x 120	14,0	13,35
AL70	7,0 x 125	15,0	13,91
AL80	8,0 x 125	17,0	17,37
AL90	9,0 x 135	19,0	17,84

	$\square \times L_1$ mm	D_1	AL €
AL100	10,0 x 140	21,0	24,65
AL110	11,0 x 150	23,0	24,99
AL120	12,0 x 160	25,0	26,91
AL130	13,0 x 165	27,0	42,10
AL145	14,5 x 175	29,0	42,69
AL160	16,0 x 185	30,0	45,17
AL180	18,0 x 195	33,0	51,47
AL200	20,0 x 220	36,0	68,65
AL220	22,0 x 220	40,0	100,33
AL240	24,0 x 235	42,0	153,66
AL260	26,0 x 245	45,0	162,25
AL290	29,0 x 260	55,0	187,20
AL320	32,0 x 280	55,0	230,45

Maximum Performance
150 kg/mm²

DROP FORGED TAP HOLDERS

Ref. GAPRO

- Drop Forged Steel body.
- Tensile Strength up to 150 Kg/mm2.
- Maximum performance and lifetime.

- Accurate and tight tap holding.
- Adjusted and reinforced thread provides robust tool.
- Anti slip handle for a smooth grip.



GAPRO

NORM N°	N° 0	N° 1	N° 1.1/2	N° 2	N° 3	N° 4	N° 5
	M1-M8 2,00-5,00	M1-M10 2,00-6,30	M1-M12 2,50-7,00	M1-M12 2,50-8,00	M5-M20 4,00-13,00	M5-M27 4,00-16,00	M9-M32 5,50-20,00
€	21,41	22,62	24,04	30,38	42,99	68,74	145,49

Ref. GA

- Zinc Alloy Body.
- High performance and lifetime.
- Accurate and precise grip.



GA

NORM N°	N° 0	N° 1	N° 1.1/2	N° 2	N° 3	N° 4	N° 5	N° 7	N° 8
	M1-M8 1,50-5,00	M1-M10 2,00-7,00	M1-M12 2,00-8,00	M4-M12 2,50-10,00	M5-M20 3,50-14,00	M9-M27 4,00-15,00	M13-M32 5,50-19,00	M22-M52 14,00-34,00	M33-M64 16,00-40,00
€	17,99	19,02	20,20	25,52	36,12	57,77	122,26	241,52	394,59

DIE HOLDERS WITH 5 AND 3 SCREWS

Ref. VA

**DIN
225**



IMPORTANT: When placing an order, please use the thicknesses mentioned below

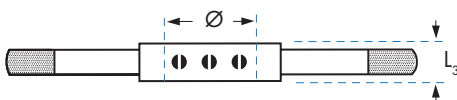

Ø x L3 mm	16x5	20x5	20x7	25x9	30x11	38x10	38x14	45x14	45x18	55x16	55x22	65x18	65x25
€	9,99	11,06	11,06	12,62	15,29	19,99	19,96	24,54	24,72	31,72	33,22	45,45	45,45
Ø x L3 mm	75x20	75x30	90x22	90x36	105x22	105x36	120x22	120x36	130x25	130x36	140x25		
€	78,75	82,43	99,75	107,47	148,41	148,41	385,98	385,98	401,27	401,27	421,98		

VA

Ref. VA

INCHES



Ø mm	20,60	25,40	38,10	50,80	63,50	76,20	88,90
Inches	13/16"	1"	1.1/2"	2"	2.1/2"	3"	3.1/2"
€	10,83	12,85	19,23	28,52	45,01	83,23	105,43

VA

NOTE: Die holders with imperial exterior Ø are now obsolete

"T" TAP WRENCHES WITH RATCHET

Tool holder

Pink

Ref. TC

TYPE
T

SHORT SERIES



	CAPACITY mm min.-max.	For tap shanks		L ₁ mm	WEIGHT g	QUALITY	TC
		DIN	ISO				€
TC3B	2,6 - 5,5	M3 - 8	M3 - 6	85	180	1 st Quality	29,38
TC4B	4,6 - 8,0	M5 - 12	M6 - 12	110	300	1 st Quality	39,70
TC1B	2,6 - 5,5	M3 - 8	M3 - 6	85	180	2 nd Quality	22,25
TC2B	4,6 - 8,0	M5 - 12	M6 - 12	110	300	2 nd Quality	29,84

Ref. TL

TYPE
T

LONG SERIES



	CAPACITY mm min.-max.	For tap shanks		L ₁ mm	WEIGHT g	QUALITY	TL
		DIN	ISO				€
TL3	2,6 - 5,5	M3 - 8	M3 - 6	250	250	1 st Quality	44,69
TL4	4,6 - 8,0	M5 - 12	M6 - 12	300	440	1 st Quality	53,20
TL1	2,6 - 5,5	M3 - 10	M3 - 6	250	250	2 nd Quality	35,29
TL2	4,6 - 8,0	M5 - 12	M6 - 12	300	440	2 nd Quality	42,05

METHACRYLATE DISPLAYS

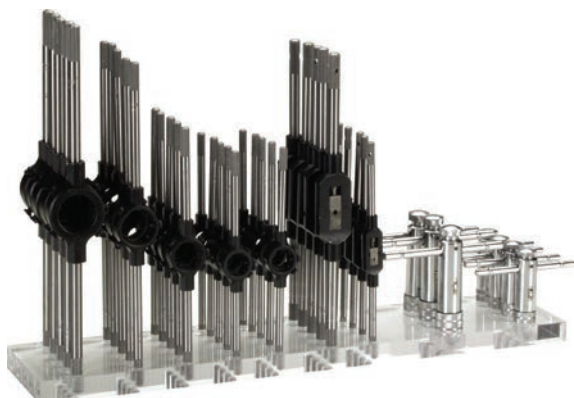

Dimensions: 500 x 320 x 110 mm

				GV-01
				€
GV-01	N° <u>1</u> / <u>2</u> 5 5	<u>20x5</u> <u>20x7</u> <u>25x9</u> 5 5 5 <u>30x11</u> <u>38x14</u> 5 5	<u>TC1</u> <u>TC2</u> 4 4	773,85

HAND TAPS AND DIES IN METAL CASE



**M3
M12**

HSS



Ref. D624

CONTENT

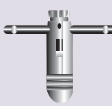
					No. Items	1st Quality €	* 2nd Quality €
D624	M3 - M4 - M5 - M6 - M8 - M10 - M12	N° 1.1/2	25 x 9	-	30	250,75	227,47

HSS DIES IN METAL CASE



**M3
M12**

HSS



Ref. D671

CONTENT

					No. Items	1st Quality €	* 2nd Quality €
D671	M3 - M4 - M5 - M6 - M8 - M10 - M12	20 x 5 30 x 11	20 x 7 38 x 14	25 x 9	12	247,34	209,50
D671I (Left hand)	 M3 - M4 - M5 - M6 - M8 - M10 - M12	20 x 5 30 x 11	20 x 7 38 x 14	25 x 9	12	494,67	418,97

* 2nd Quality: Die holder and tap holder in ZAMAK

HSS AND HSSCo HAND TAPS AND DIES IN METAL CASES
**M3
M12**

HSS
**HSSCo
5%**

Ref. D621



Ref. D655

CONTENT

							No. Items	1st Quality €	**2nd Quality €
D621	M3 - M4 - M5 - M6 M8 - M10 - M12	2.5 / 3.3 / 4.2 / 5.0 6.8 / 8.5 / 10.2 mm	Nº 1 Nº 2	20 x 5 20 x 7 25 x 9 30 x 11 38 x 14	TC1	43	502,79	368,52	
D652	M3 - M4 - M5 - M6 M8 - M10 - M12	2.5 / 3.3 / 4.2 / 5.0 6.8 / 8.5 / 10.2 mm	Nº 1 Nº 2	20 x 5 20 x 7 25 x 9 30 x 11 38 x 14	-	42	486,69	349,96	
D662	M3-M4-M5-M6-M7 M8-M9-M10-M11-M12	-	Nº 1 Nº 2	20 x 5 20 x 7 25 x 9 30 x 11 38 x 14	TC1	48	749,01	658,81	
D651	M3 - M4 - M5 - M6 M8 - M10 - M12	-	Nº 1 Nº 2	20 x 5 20 x 7 25 x 9 30 x 11 38 x 14	-	35	384,13	353,39	
D655* (HSSCo)	M3 - M4 - M5 - M6 M8 - M10 - M12	2.5 / 3.3 / 4.2 / 5.0 6.8 / 8.5 / 10.2 mm	Nº 1 Nº 2	20 x 5 20 x 7 25 x 9 30 x 11 38 x 14	TC1	43	802,08	705,53	
D621I (Left hand)	M3 - M4 - M5 - M6 M8 - M10 - M12	2.5 / 3.3 / 4.2 / 5.0 6.8 / 8.5 / 10.2 mm	Nº 1 Nº 2	20 x 5 20 x 7 25 x 9 30 x 11 38 x 14	TC1	43	785,25	684,80	

*

**HSSCo
5%**

**** 2nd Quality: Die holder and tap holder in ZAMAK**

HSS AND HSSCo HAND TAPS AND DIES IN METAL CASES WITH GUIDES FOR DIES

M3 M12 HSS HSSCo 5%



Ref. D656



PILOT GUIDE









Ref. D657

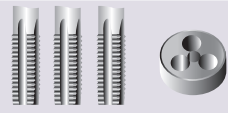

PILOT GUIDE

CONTENT

						No. Items	1st Quality €	** 2nd Quality €
D656	M3 - M4 - M5 - M6 M8 - M10 - M12	2.5 / 3.3 / 4.2 / 5.0 6.8 / 8.5 / 10.2 mm	N° 1 N° 2	+ PILOT GUIDE 20x5 20x7 25x9 30x11 38x14	TC1	43	561,85	497,37
D657* (HSSCo)	M3 - M4 - M5 - M6 M8 - M10 - M12	2.5 / 3.3 / 4.2 / 5.0 6.8 / 8.5 / 10.2 mm	N° 1 N° 2	+ PILOT GUIDE 20x5 20x7 25x9 30x11 38x14	TC1	43	836,41	738,24

* HSSCo 5%  

** 2nd Quality: Die holder and tap holder in ZAMAK

HSS AND HSSCo HAND TAPS AND DIES IN METAL CASES
**M3
M20**
**M5
M20**
HSS
**HSSCo
5%**

Ref. D622



Ref. D623

CONTENT

					No. Items	1st Quality €	**2nd Quality €
D622 (Automotive)	M3 - M4 - M5 - M6 - M8 - M10 - M12 M14 - M16 - M18 - M20	Nº 1 Nº 3	20 x 5 20 x 7 25 x 9 30 x 11 38 x 14 45 x 18	TC1 TC2	54	859,95	675,64
D658	M3 - M4 - M5 - M6 - M8 - M10 - M12 M14 - M16 - M18 - M20	Nº 1 Nº 3	20 x 5 20 x 7 25 x 9 30 x 11 38 x 14 45 x 18	-	52	792,21	611,27
D622I (Left hand)	M3 - M4 - M5 - M6 - M8 - M10 - M12 M14 - M16 - M18 - M20	Nº 1 Nº 3	20 x 5 20 x 7 25 x 9 30 x 11 38 x 14 45 x 18	TC1 TC2	54	1.480,89	-
D659* (HSSCo)	M3 - M4 - M5 - M6 - M8 - M10 - M12 M14 - M16 - M18 - M20	Nº 1 Nº 3	20 x 5 20 x 7 25 x 9 30 x 11 38 x 14 45 x 18	-	52	1.786,29	1.571,22
D623	M5 - M6 - M8 - M10 - M12 M14 - M16 - M18 - M20	Nº 1 Nº 3	20 x 7 25 x 9 30 x 11 38 x 14 45 x 18	TC1 TC2	45	901,60	705,86
D663	M5 - M6 - M7 - M8 - M9 - M10 - M12 M14 - M16 - M18 - M20	Nº 1 Nº 3	20 x 7 25 x 9 30 x 11 38 x 14 45 x 18	-	51	1.202,03	1.081,20

*

**HSSCo
5%**

** 2nd Quality: Die holder and tap holder in ZAMAK

HSS HAND TAPS AND DIES IN METAL AND WOODEN CASES

M1
M10
M5
M12
M3
M24
M5
M30
HSS



Ref. D628



Ref. D626

CONTENT

					No. Items	1st Quality €	* 2nd Quality €
D626	M1 - M1.2 - M1.4 - M1.7 - M2.0 - M2.3 M2.6 - M3 - M3.5 - M4 - M5 - M6 - M8 - M10	N° 0 N° 1	16 x 5 20 x 5 20 x 7 25 x 9 30 x 11	TC1	64	-	1.124,71
D627	M5 - M6 - M7 - M8 - M9 - M10 - M11 - M12	N° 1 N° 2	20 x 7 25 x 9 30 x 11 38 x 14	TC1	39	-	840,21
D625	M3 - M4 - M5 - M6 - M8 - M10 - M12 - M14 M16 - M18 - M20 - M22 - M24	N° 1 N° 4	20 x 5 20 x 7 25 x 9 30 x 11 38 x 14 45 x 18 55 x 22	-	61	1.984,50	1.464,24
D628	M5 - M6 - M8 - M10 - M12 - M14 - M16 M18 - M20 - M22 - M24 - M27 - M30	N° 1 N° 3 N° 5	20 x 7 25 x 9 30 x 11 38 x 14 45 x 18 55 x 22 65 x 25	-	62	-	2.680,11

* 2nd Quality: Die holder and tap holder in ZAMAK





HSS HAND TAPS AND DIES IN METAL CASES
MF
HSS

Ref. D634

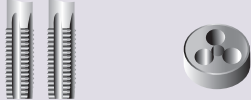

Ref. D636

CONTENT

					No. Items	1st Quality €	* 2nd Quality €
D634	MF 3 x 0.35 - 4 x 0.5 - 5 x 0.5 MF 6 x 0.75 - 8 x 0.75 - 8 x 1.0 MF 10 x 1.0 - 12 x 1.5	Nº 1 Nº 2	20 x 5 25 x 9 30 x 11 38 x 10	TC1	31	-	770,87
D635	MF 6 x 0.75 - 8 x 0.75 - 8 x 1.0 - 10 x 1.0 MF 12 x 1.0 - 12 x 1.5 - 14 x 1.25 - 14 x 1.5 MF 16 x 1.5 - 18 x 1.5 - 20 x 1.5	Nº 1 Nº 3	20 x 7 25 x 9 30 x 11 38 x 10 45 x 14	-	40	1.257,45	1.195,74
D636	MF 6 x 0.75 - 8 x 0.75 - 8 x 1.0 - 10 x 1.0 MF 12 x 1.0 - 12 x 1.5 - 14 x 1.25 - 14 x 1.5 MF 16 x 1.5 - 18 x 1.5 - 20 x 1.5 - 22 x 1.5 MF 24 x 1.5	Nº 1 Nº 4	20 x 7 25 x 9 30 x 11 38 x 10 45 x 14 55 x 16	-	47	1.724,99	1.594,87





* 2nd Quality: Die holder and tap holder in ZAMAK

HSS HAND TAPS AND DIES IN METAL CASES



Ref. D638

CONTENT



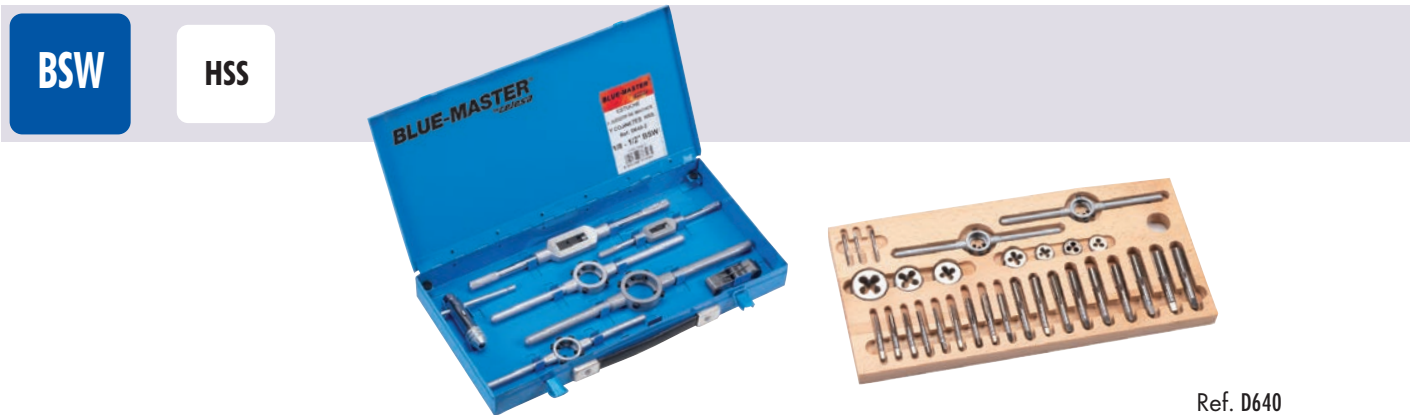

					No. Items	1st Quality €	* 2nd Quality €
D637	G 1/8 - 1/4 - 3/8 - 1/2 - 3/4 - 1"	Nº 1 Nº 3 Nº 5	30 x 11 38 x 10 45 x 14 55 x 16 65 x 18	-	26	1.396,16	1.127,80
D638	G 1/8 - 1/4 - 3/8 - 1/2 - 5/8 - 3/4 - 7/8 - 1"	Nº 1 Nº 3 Nº 5	30 x 11 38 x 10 45 x 14 55 x 16 65 x 18	-	32	1.894,73	1.653,96
D639	G 1/4 - 3/8 - 1/2 - 3/4 - 1" - 1".1/4 - 1".1/2	Nº 2 Nº 4 Nº 7	38 x 10 45 x 14 55 x 16 65 x 18 75 x 20 90 x 22	-	30	3.495,46	2.948,56

* 2nd Quality: Die holder and tap holder in ZAMAK

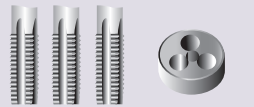

Ref. D640

CONTENT





					No. Items	1st Quality €	* 2nd Quality €
D640	BSW 1/8 - 3/16 - 1/4 - 5/16 - 3/8 - 7/16 - 1/2	Nº 1 Nº 2	20 x 5 20 x 7 25 x 9 30 x 11 38 x 14	TC1	36	778,86	665,81
D641	BSW 1/4 - 5/16 - 3/8 - 7/16 - 1/2	Nº 1 Nº 2	20 x 7 25 x 9 30 x 11 38 x 14	TC1	27	642,07	540,80
D642	BSW 1/4 - 5/16 - 3/8 - 7/16 - 1/2 - 5/8 - 3/4	Nº 1 Nº 3	20 x 7 25 x 9 30 x 11 38 x 14 45 x 18	-	35	1.149,07	1.048,48
D643	BSW 1/4 - 5/16 - 3/8 - 7/16 1/2 - 5/8 - 3/4 - 7/8 - 1"	Nº 1 Nº 4	20 x 7 25 x 9 30 x 11 38 x 14 45 x 18 55 x 22	-	44	1.625,05	1.426,74
D646	BSW 1/4 - 5/16 - 3/8 - 7/16 1/2 - 5/8 - 3/4 - 7/8 - 1" - 1".1/8 1".1/4 - 1".3/8 - 1".1/2	Nº 1 Nº 3 Nº 5	20 x 7 25 x 9 30 x 11 38 x 14 45 x 18 55 x 22 65 x 25	-	62	-	4.335,52

* 2nd Quality: Die holder and tap holder in ZAMAK

HSS HAND TAPS AND DIES IN METAL CASES
BSF
HSS

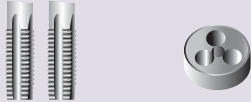
Ref. D648

CONTENT



					No. Items	1st Quality €	* 2nd Quality €
D664	BSF 1/4 - 5/16 - 3/8 - 7/16 - 1/2	Nº 1 Nº 2	20 x 7 25 x 9 30 x 11 38 x 10	TC1	22	718,02	631,56
D648	BSF 1/4 - 5/16 - 3/8 - 7/16 - 1/2 - 5/8 - 3/4	Nº 1 Nº 3	20 x 7 25 x 9 30 x 11 38 x 10 45 x 14	-	28	1.114,65	1.048,48
D665	BSF 1/4 - 5/16 - 3/8 - 7/16 1/2 - 5/8 - 3/4 - 7/8 - 1"	Nº 1 Nº 4	20 x 7 25 x 9 30 x 11 38 x 10 45 x 14 55 x 16	-	35	1.891,38	1.663,64

* 2nd Quality: Die holder and tap holder in ZAMAK

**BSW
BSF**
HSS

Ref. D666

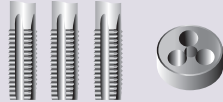
CONTENT

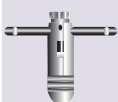
					No. Items	1st Quality €	* 2nd Quality €
D666	BSW 1/4 - 5/16 - 3/8 - 7/16 - 1/2 - 5/8 - 3/4 BSF 1/4 - 5/16 - 3/8 - 7/16 - 1/2 - 5/8 - 3/4	Nº 1 Nº 3	20 x 7 25 x 9 30 x 11 38 x 14 45 x 18	-	63	2.136,56	1.879,30





* 2nd Quality: Die holder and tap holder in ZAMAK

HSS HAND TAPS AND DIES IN METAL CASES



Ref. D660

CONTENT





						No. Items	1st Quality €	* 2nd Quality €
D660	NPT 1/8 - 1/4 - 3/8 - 1/2 - 3/4 - 1"		Nº1 Nº3 Nº5	30 x 11 38 x 14 45 x 18 55 x 22 65 x 25	-	20	2.019,60	1.915,69
D661	NPT 1/8 - 1/4 - 3/8 - 1/2 - 3/4 1" - 1.1/4 - 1.1/2 - 2"		Nº2 Nº4 Nº7	30 x 11 38 x 14 45 x 18 55 x 22 65 x 25 75 x 30 90 x 36 105 x 36	-	29	6.045,65	5.679,86

* 2nd Quality: Die holder and tap holder in ZAMAK

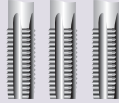

Ref. D650

CONTENT





						No. Items	1st Quality €	* 2nd Quality €
D650	UNC 1/4 - 5/16 - 3/8 - 7/16 - 1/2		Nº1 Nº2	20 x 7 25 x 9 30 x 11 38 x 14	TC1	27	782,61	702,43
D667	UNC 1/4 - 5/16 - 3/8 - 7/16 - 1/2 - 5/8 - 3/4		Nº1 Nº2	20 x 7 25 x 9 30 x 11 38 x 14 45 x 18	-	35	1.260,92	1.109,09
D654	UNC 1/4 - 5/16 - 3/8 - 7/16 1/2 - 5/8 - 3/4 - 7/8 - 1"		Nº1 Nº4	20 x 7 25 x 9 30 x 11 38 x 14 45 x 18 55 x 22	-	44	2.034,61	1.904,14
D668	UNC 1/4 - 5/16 - 3/8 - 7/16 - 1/2 - 5/8 - 3/4 7/8 - 1" - 1.1/8 - 1.1/4 - 1.3/8 - 1.1/2"		Nº1 Nº3 Nº6	20 x 7 25 x 9 30 x 11 38 x 14 45 x 18 55 x 22 65 x 25	-	62	4.763,45	4.189,89

* 2nd Quality: Die holder and tap holder in ZAMAK

HSS HAND TAPS AND DIES IN METAL CASES
UNF
HSS

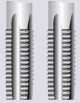
Ref. D644

CONTENT



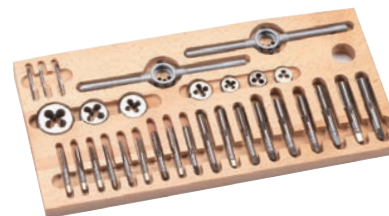

						No. Items	1st Quality €	* 2nd Quality €
D644	UNF 1/4 - 5/16 - 3/8 - 7/16 - 1/2		Nº 1 Nº 2	20 x 7 25 x 9 30 x 11 38 x 10	TC1	22	613,25	531,63
D669	UNF 1/4-5/16-3/8-7/16-1/2-5/8-3/4		Nº 1 Nº 3	20 x 7 25 x 9 30 x 11 38 x 10 45 x 14	-	28	1.155,83	1.016,66
D645	UNF 1/4 - 5/16 - 3/8 - 7/16 - 1/2 - 5/8 3/4 - 7/8 - 1"		Nº 1 Nº 4	20 x 7 25 x 9 30 x 11 38 x 10 45 x 14 55 x 16	-	34	1.417,28	1.285,05

* 2nd Quality: Die holder and top holder in ZAMAK

**UNC
UNF**
HSS

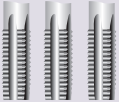
Ref. D670

CONTENT

						No. Items	1st Quality €	* 2nd Quality €
D670	UNC 1/4 - 5/16 - 3/8 - 7/16 - 1/2 - 5/8 - 3/4 UNF 1/4 - 5/16 - 3/8 - 7/16 - 1/2 - 5/8 - 3/4		Nº 1 Nº 3	20 x 7 25 x 9 30 x 11 38 x 14 45 x 18	-	35	2.136,56	1.879,30

* 2nd Quality: Die holder and top holder in ZAMAK

HSS & TIN COATED HAND TAPS SETS IN METAL BOXES



Ref. JMB0



Ref. JMB2



Ref. JMBT2

CONTENT

					HSS €		TiN* €
JMB2	M3 - M4 - M5 - M6 M8 - M10 - M12	-	-	-	198,53	JMBT2	394,19
JMB0	M3 - M4 - M5 - M6 M8 - M10 - M12	2.5 / 3.3 / 4.2 / 5.0 6.8 / 8.5 / 10.2 mm	-	-	226,46	JMBT0	442,36
JMB1	M3 - M4 - M5 - M6 M8 - M10 - M12	2.5 / 3.3 / 4.2 / 5.0 6.8 / 8.5 / 10.2 mm	Nº 1.1/2	-	243,73	JMBT1	379,06
JMB5	M3 - M4 - M5 - M6 M8 - M10 - M12	2.5 / 3.3 / 4.2 / 5.0 6.8 / 8.5 / 10.2 mm	Nº 1.1/2	TC1	258,87	JMBT5	397,19
JMB12 (Left hand)	M3 - M4 - M5 - M6 M8 - M10 - M12	-	-	-	368,17	JMBIT2	684,78
JMB10 (Left hand)	M3 - M4 - M5 - M6 M8 - M10 - M12	2.5 / 3.3 / 4.2 / 5.0 6.8 / 8.5 / 10.2 mm	-	-	426,50	JMBIT0	742,74
JMB11 (Left hand)	M3 - M4 - M5 - M6 M8 - M10 - M12	2.5 / 3.3 / 4.2 / 5.0 6.8 / 8.5 / 10.2 mm	Nº 1.1/2	-	443,15	JMBIT1	758,13

HSS AND TIN COATED BOTTOMING TAPS IN METAL BOXES



Ref. JMB3



Ref. JMB4

CONTENT

					HSS €		TiN* €
JMB3	M3 - M4 - M5 - M6 M8 - M10 - M12	-	-	-	91,14	JMBT3	114,13
JMB4	M3 - M4 - M5 - M6 M8 - M10 - M12	2.5 / 3.3 / 4.2 / 5.0 6.8 / 8.5 / 10.2 mm	-	-	113,43	JMBT4	150,77
JMB7	M3 - M4 - M5 - M6 M8 - M10 - M12	2.5 / 3.3 / 4.2 / 5.0 6.8 / 8.5 / 10.2 mm	Nº 1.1/2	-	129,80	JMBT7	209,14
JMB6	M3 - M4 - M5 - M6 M8 - M10 - M12	2.5 / 3.3 / 4.2 / 5.0 6.8 / 8.5 / 10.2 mm	Nº 1.1/2	TC1	140,55	JMBT6	222,91
JMB13 (Left hand)	M3 - M4 - M5 - M6 M8 - M10 - M12	-	-	-	122,71	JMBIT3	228,25
JMB14 (Left hand)	M3 - M4 - M5 - M6 M8 - M10 - M12	2.5 / 3.3 / 4.2 / 5.0 6.8 / 8.5 / 10.2 mm	-	-	164,44	JMBIT4	302,56





HSSCo HAND TAPS IN METAL BOXES
HSSCo
5%

Ref. JMBX0

CONTENT

INOX	 MOX	 HSSCo			€
JMBX0	M3 - M4 - M5 - M6 M8 - M10 - M12	2.5 / 3.3 / 4.2 / 5.0 6.8 / 8.5 / 10.2 mm	-	-	312,94
JMBX1	M3 - M4 - M5 - M6 M8 - M10 - M12	2.5 / 3.3 / 4.2 / 5.0 6.8 / 8.5 / 10.2 mm	Nº 1.1/2	-	329,35
JMBX2	M3 - M4 - M5 - M6 M8 - M10 - M12	-	-	-	295,92

CONTENT

 1100 N/mm ²	 MOMD	 HSSCo			€
JMBMD0	M3 - M4 - M5 - M6 M8 - M10 - M12	2.5 / 3.3 / 4.2 / 5.0 6.8 / 8.5 / 10.2 mm	-	-	326,82
JMBMD1	M3 - M4 - M5 - M6 M8 - M10 - M12	2.5 / 3.3 / 4.2 / 5.0 6.8 / 8.5 / 10.2 mm	Nº 1.1/2	-	343,82
JMBMD2	M3 - M4 - M5 - M6 M8 - M10 - M12	-	-	-	311,53

HSS DIES IN METAL BOXES

Ref. C5B3



CONTENT

		HSS
		€
C5B3	M3 - M4 - M5 - M6 - M8 - M10 - M12	237,19
C5B31 (Left hand)	M3 - M4 - M5 - M6 - M8 - M10 - M12	469,78



BROKEN TAP EXTRACTOR FOR STRAIGHT FLUTE TAPS (WITHOUT HELIX)



SINGLE EXTRACTORS

TAP EXTRACTOR SIZE Ø		HAND TAPS	MACHINE TAPS	€/ Unit
BSW UNC	M			COMPLETE EXTRACTOR
--	M3		W10043	45,23
1/8	M3,2		W10053	45,23
--	M3,5		W10063	45,23
5/32	M4		W10083	45,23
3/16	M5		W10103	45,23
--	M5,5	W10124	W10123	45,23
1/4	M6	W10254	W10253	46,56
5/16	M8	W10314	W10313	48,79
--	M9	W10374	W10373	48,33
3/8	M10	W10404	W10373	48,33
7/16	M11	W10434	W10433	51,02
1/2	M12	W10504	W10503	54,55
9/16	M14	W10564	W10563	75,39
5/8	M16	W10624	W10623	82,05
--	M18	W10684	W10753	101,66
3/4	M20	W10754	W10753	101,66
7/8	M22	W10874	W10873	111,24
1"	M25	W11004	W11003	124,05

SPARE HOLDER

HAND TAPS	MACHINE TAPS	€/ Unit
		EXTRA HOLDER
	W12043	2,41
	W12053	2,41
	W12063	2,41
	W12083	2,41
	W12103	3,59
	W12123	3,59
	W12253	4,38
W12314	W12313	4,94
W12374		4,94
W12404	W12373	5,10
W12434	W12433	5,18
W12504	W12503	6,52
W12564	W12563	7,27
W12624	W12623	9,30
W12684		9,30
W12754	W12753	9,84
W12874	W12873	12,75
W13004	W13003	21,22

3 SIMPLE STEPS FOR REMOVING BROKEN TAPS WITH STRAIGHT FLUTES

Thoroughly remove all chips of the broken tap. Insert the extractors fingers into the flutes of the broken tap, pushing them gently but firmly into position.



Push the holder down until it touches the broken tap. Slide the sleeve down until it touches the work piece.



Apply a tap wrench to the square end of the holder. Twist forward & backwards a few times to loosen, then back out the broken tap.

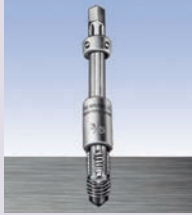

BROKEN TAP EXTRACTORS SETS FOR STRAIGHT FLUTES TAPS

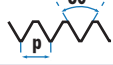
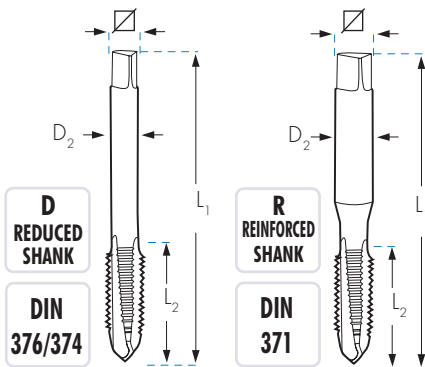

	NUMBER OF FLUTES	SIZES INCLUDED FOR MACHINE & HAND TAPS: 3 AND 4 FLUTES	
W180013	3	M5- M6- M8- M10- M11- M12	313,57
W180014	4	3/16 - 1/4 - 5/16 - 3/8 - 7/16 - 1/2	
W180023	3	M6- M8 -M10- M11- M12- M16	352,79
W180024	4	1/4 - 5/16 - 3/8 - 7/16 - 1/2 - 5/8	
W180153	3	M3- M3,2- M3,5- M4-M5- M5,50- M6- M8	986,83
W180154	4	M9- M10- M12- M16- M18- M22- M25	

HSSCo MACHINE TAPS
M
MF
DIN 13

HSSCo
5%
TOL
6H
Vc
12 m/min

			L1 x L2 x D2 x \square mm	M1D	M2D	M3D	M4D	M1R	M2R	M3R	M4R
				C FORM €	B FORM €	 15° €	 35° €	C FORM €	B FORM €	 15° €	 35° €
M 1x0,25	0,75	R	40 x 5,5 x 2,5 x 2,1					43,34			
M 1,1x0,25	0,85	R	40 x 6 x 2,5 x 2,1					42,16			
M 1,2x0,25	0,95	R	40 x 6 x 2,5 x 2,1					38,51			
M 1,4x0,30	1,10	R	40 x 7 x 2,5 x 2,1					38,51			
M 1,6x0,35	1,25	R	40 x 8 x 2,5 x 2,1					37,82			
M 1,7x0,35	1,35	R	40 x 8 x 2,5 x 2,1					36,42			
M 1,8x0,35	1,45	R	40 x 8 x 2,5 x 2,1					35,52			
M 2x0,40	1,60	R	40 x 8 x 2,8 x 2,1					17,10	18,95	21,19	21,59
M 2,2x0,45	1,75	R	40 x 9 x 2,8 x 2,1					18,49			
M 2,3x0,40	1,90	R	40 x 9 x 2,8 x 2,1					17,03			
M 2,5x0,45	2,05	R	50 x 9 x 2,8 x 2,1					17,10	18,95	29,79	21,59
M 2,6x0,45	2,10	R	50 x 9 x 2,8 x 2,1					17,13	19,29		35,89
M 3x0,50	2,50	R D	56 x 11 x 3,5 x 2,7 56 x 11 x 2,2 x 1,8	11,33	12,27	17,08	14,72	11,33*	11,51	16,74	15,09
M 3x0,60	2,40	R	56 x 11 x 3,5 x 2,7					20,14	21,98		29,03
M 3,5x0,60	2,90	R D	56 x 12 x 4,0 x 3,0 56 x 12 x 2,5 x 2,1					16,47	17,14	22,14	20,78
M 3,5x0,75	2,75	R	56 x 12 x 4,0 x 3,0					21,77			
M 4x0,50	3,50	R D	63 x 13 x 4,5 x 3,4 63 x 13 x 2,8 x 2,1	24,81	27,32		28,89	23,71	26,38		30,54
M 4x0,70	3,30	R D	63 x 13 x 4,5 x 3,4 63 x 13 x 2,8 x 2,1	11,53	12,40	18,31	14,58	12,89*	12,16	16,52	15,10
M 4x0,75	3,25	R	63 x 13 x 4,5 x 3,4					18,03	19,25		
M 4x0,80	3,20	R	63 x 13 x 4,5 x 3,4					95,70			
M 4,5x0,50	4,00	R	70 x 14 x 6,0 x 4,9						30,69		
M 4,5x0,75	3,75	R	70 x 14 x 6,0 x 4,9					22,25	24,50		
M 5x0,50	4,50	R D	70 x 14 x 6,0 x 4,9 70 x 11 x 3,5 x 2,7	25,55	28,07		29,21	24,42	27,10		32,58
M 5x0,75	4,50	R D	74 x 14 x 6,0 x 4,9 70 x 16 x 3,5 x 2,7					21,90	25,69		32,37
M 5x0,80	4,20	R D	70 x 16 x 6,0 x 4,9 70 x 16 x 3,5 x 2,7	11,53	12,47	17,55	14,00	11,54*	12,18	15,85	14,48
M 5x0,90	4,10	R D	70 x 15 x 6,0 x 4,9 70 x 16 x 3,5 x 2,7					19,05	24,54		
M 5x1,00	4,00	R	72 x 17 x 6,0 x 4,9					51,02			
M 5,5x0,90	4,60	R	80 x 17 x 6,0 x 4,9					51,02			
M 6x0,50	5,50	R D	80 x 17 x 6,0 x 4,9 80 x 13 x 4,5 x 3,4	30,25	37,09		46,80	31,97			
M 6x0,75	5,25	R D	80 x 13 x 6,0 x 4,9 80 x 13 x 4,5 x 3,4	19,93	23,08		26,95	20,71	24,13		28,98
M 6x1,00	5,00	R D	80 x 19 x 6,0 x 4,9 80 x 19 x 4,5 x 3,4	13,15	13,66	18,36	15,35	13,13*	13,36	17,39	15,88

* Check the price of left hand taps available in page 217.

* Vc: Cutting Speed (m/min)

HSSCo MACHINE TAPS











Tap Type	L1 x L2 x D2 x mm	M1D		M2D		M3D		M4D		M1R		M2R		M3R		M4R	
		C FORM	B FORM	C FORM	B FORM	15°	35°	C FORM	B FORM	15°	35°	C FORM	B FORM	15°	35°	C FORM	B FORM
		€	€	€	€	€	€	€	€	€	€	€	€	€	€	€	€
M 6x1,25	4,75 R 80 x 17 x 6,0 x 4,9									50,15							
M 7x0,75	6,25 D 80 x 13 x 5,5 x 4,3	25,66	28,46				35,15										
M 7x1,00	6,00 R 80 x 19 x 7,0 x 5,5 D 80 x 19 x 5,5 x 4,3	17,69	20,45	22,09	21,26			17,03*	19,88	22,48	22,25						
M 8x0,50	7,50 D 80 x 13 x 6 x 4,9	34,51															
M 8x0,75	7,25 D 80 x 13 x 6 x 4,9	25,00	30,66				38,02										
M 8x1,00	7,00 D 90 x 20 x 6 x 4,9	20,45	23,47	28,12	26,00												
M 8x1,25	6,80 R 90 x 22 x 8 x 6,2 D 90 x 22 x 6 x 4,9	14,75	15,41	20,90	17,92			14,84*	14,85	20,02	18,14						
M 8x1,50	6,50 D 90 x 20 x 6 x 4,9	101,14															
M 9x1,00	8,00 D 90 x 20 x 7 x 5,5	30,92	33,06				35,13										
M 9x1,25	7,80 R 90 x 22 x 9 x 7,0 D 90 x 22 x 7 x 5,5	24,85	26,11	31,62	30,91			24,61	24,93	31,88	31,80						
M 10x0,50	9,50 D 90 x 20 x 7 x 5,5	100,21															
M 10x0,75	9,25 D 90 x 16 x 7 x 5,5	39,64	39,72				48,37										
M 10x1,00	9,00 D 90 x 16 x 7 x 5,5	22,64	26,08	33,20	31,63												
M 10x1,25	8,80 D 100 x 22 x 7 x 5,5	25,92	31,18	36,19	34,47												
M 10x1,50	8,50 R 100 x 24 x 10 x 8,0 D 100 x 24 x 7 x 5,5	16,67	18,64	24,85	21,48			16,82*	18,29	22,99	21,48						
M 11x1,00	10,00 D 90 x 20 x 8 x 6,2	40,58	41,91	105,96	96,42												
M 11x1,25	9,75 D 100 x 22 x 8 x 6,2	38,83	43,14	105,96	86,07												
M 11x1,50	9,50 D 100 x 24 x 8 x 6,2	31,48	36,19	77,26	70,27												
M 12x0,75	11,25 D 100 x 22 x 9 x 7,0	59,46															
M 12x1,00	11,00 D 100 x 22 x 9 x 7,0	30,79	35,24	40,96	40,52												
M 12x1,25	10,75 D 100 x 22 x 9 x 7,0	31,17	34,62	39,22	38,79												
M 12x1,50	10,50 D 100 x 22 x 9 x 7,0	27,86*	30,88	37,71	37,31												
M 12x1,75	10,20 D 110 x 28 x 9 x 7,0	20,08*	23,28	31,78	27,39												
M 13x0,75	12,25 D 100 x 22 x 11 x 9,0	103,78															
M 13x1,00	12,00 D 100 x 22 x 11 x 9,0	54,96	62,23														
M 13x1,25	11,75 D 100 x 22 x 11 x 9,0	54,96	62,23														
M 13x1,50	11,50 D 100 x 22 x 11 x 9,0	54,96	62,23														
M 13x1,75	11,25 D 100 x 28 x 11 x 9,0	54,57	62,23														
M 14x0,75	13,25 D 100 x 22 x 11 x 9,0	103,78															
M 14x1,00	13,00 D 100 x 22 x 11 x 9,0	49,56	54,52	63,15	62,62												
M 14x1,25	12,80 D 100 x 22 x 11 x 9,0	42,18	46,04	57,92	55,18												
M 14x1,50	12,50 D 100 x 22 x 11 x 9,0	33,18*	36,56	45,68	43,51												
M 14x2,00	12,00 D 110 x 30 x 11 x 9,0	32,96*	36,62	42,44	42,44												
M 15x1,00	14,00 D 100 x 22 x 12 x 9,0	63,03	66,73		84,97												
M 15x1,25	13,75 D 100 x 22 x 12 x 9,0	67,51	73,11														
M 15x1,50	13,50 D 100 x 22 x 12 x 9,0	53,96	61,54	157,22	127,53												
M 15x2,00	13,00 D 110 x 30 x 12 x 9,0	66,05	72,69														
M 16x1,00	15,00 D 100 x 22 x 12 x 9,0	59,41	63,03	88,42	85,85												
M 16x1,25	14,75 D 100 x 22 x 12 x 9,0	63,57	69,88	98,33	95,22												
M 16x1,50	14,50 D 100 x 22 x 12 x 9,0	39,23*	45,71	56,92	54,23												
M 16x2,00	14,00 D 110 x 32 x 12 x 9,0	38,79*	42,84	51,27	51,27												
M 17x1,00	16,00 D 100 x 22 x 12 x 9,0	118,20															
M 17x1,25	15,75 D 100 x 22 x 12 x 9,0	118,20															
M 17x1,50	15,50 D 100 x 22 x 12 x 9,0	118,20															
M 18x1,00	17,00 D 110 x 25 x 14 x 11,0	66,53	73,12		105,05												
M 18x1,25	16,75 D 110 x 25 x 14 x 11,0	82,46															
M 18x1,50	16,50 D 110 x 25 x 14 x 11,0	51,94*	57,16	69,95	68,06												
M 18x2,00	16,00 D 125 x 30 x 14 x 11,0	73,30	81,23	138,42	123,54												

* Check the price of left hand taps available in page 217.

* Vc: Cutting Speed (m/min)

HSSCo MACHINE TAPS
M
MF

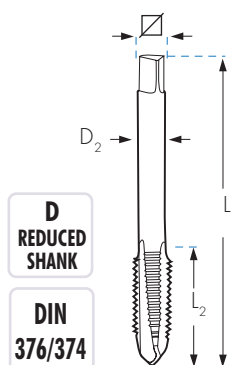
HSSCo
5%
TOL
6H
D
REDUCED
SHANK
DIN
376/374
Vc
12
m/min

			$L_1 \times L_2 \times D_2 \times \square$ mm	M1D	M2D	M3D	M4D
				C FORM €	B FORM €	 15° €	 35° €
M 18x2,50	15,50	D	125 x 34 x 14 x 11,0	55,81*	61,02	69,03	66,48
M 19x1,00	18,00	D	110 x 22 x 14 x 11,0	155,30			
M 19x1,25	17,75	D	110 x 25 x 14 x 11,0	159,71			
M 19x1,50	17,50	D	110 x 25 x 14 x 11,0	152,44			
M 20x1,00	19,00	D	125 x 25 x 16 x 12,0	87,83	97,53		112,20
M 20x1,25	18,75	D	125 x 25 x 16 x 12,0	155,30			
M 20x1,50	18,50	D	125 x 25 x 16 x 12,0	58,83*	64,65	78,62	77,75
M 20x2,00	18,00	D	140 x 32 x 16 x 12,0	77,10	84,77		100,09
M 20x2,50	17,50	D	140 x 34 x 16 x 12,0	59,41*	65,88	73,67	73,68
M 21x1,00	20,00	D	125 x 25 x 16 x 12,0	225,49			
M 21x1,25	19,75	D	125 x 25 x 16 x 12,0	225,49			
M 21x1,50	19,50	D	125 x 25 x 16 x 12,0	215,34			
M 22x1,00	21,00	D	125 x 25 x 18 x 14,5	98,46	104,50		144,59
M 22x1,25	20,75	D	125 x 25 x 18 x 14,5	155,30			
M 22x1,50	20,50	D	125 x 25 x 18 x 14,5	70,81	77,89	86,24	81,14
M 22x2,00	20,00	D	140 x 32 x 18 x 14,5	98,46	108,29		144,59
M 22x2,50	19,50	D	140 x 34 x 18 x 14,5	71,89*	79,07	87,39	86,48
M 23x1,00	22,00	D	125 x 25 x 18 x 14,5	219,22			
M 23x1,50	21,50	D	125 x 25 x 18 x 14,5	219,22			
M 24x1,00	23,00	D	140 x 25 x 18 x 14,5	107,29	130,15		152,77
M 24x1,25	22,75	D	140 x 25 x 18 x 14,5	225,49			
M 24x1,50	22,50	D	140 x 28 x 18 x 14,5	87,09	95,75	115,27	109,80
M 24x2,00	22,00	D	140 x 28 x 18 x 14,5	111,11*	121,06		130,63
M 24x3,00	21,00	D	160 x 38 x 18 x 14,5	86,06*	94,19	105,32	105,11
M 25x1,00	24,00	D	140 x 28 x 18 x 14,5	207,99			
M 25x1,25	23,75	D	140 x 28 x 18 x 14,5	328,66			
M 25x1,50	23,50	D	140 x 28 x 18 x 14,5	135,50	143,41		
M 25x2,00	23,00	D	140 x 28 x 18 x 14,5	291,68	320,86		
M 26x1,00	25,00	D	140 x 28 x 18 x 14,5	161,48			
M 26x1,50	24,50	D	140 x 28 x 18 x 14,5	117,44	123,10	215,94	189,89
M 26x2,00	24,00	D	140 x 28 x 18 x 14,5	227,46	250,21		274,82
M 27x1,00	26,00	D	140 x 28 x 20 x 16,0	144,63	186,74		
M 27x1,50	25,50	D	140 x 28 x 20 x 16,0	128,23	135,84	313,83	282,97
M 27x2,00	25,00	D	140 x 28 x 20 x 16,0	158,61*	167,83		

* Check the price of left hand taps available in page 217.

* Vc: Cutting Speed (m/min)

HSSCo MACHINE TAPS

**M
MF**

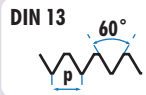

**HSSCo
5%**







**TOL
6H**

**D
REDUCED
SHANK**

**DIN
376/374**



Threading tools
Pink

			L ₁ x L ₂ x D ₂ x  mm	M1D	M2D	M3D	M4D
				C FORM €	B FORM €	 15° €	 35° €
M 27x3,00	24,00	D	160 x 36 x 20 x 16	107,43*	117,81	129,58	129,33
M 28x1,00	27,00	D	140 x 28 x 20 x 16	291,68			
M 28x1,50	26,50	D	140 x 28 x 20 x 16	128,23	140,78	163,43	147,55
M 28x2,00	26,00	D	140 x 28 x 20 x 16	156,44	176,68	192,60	189,40
M 30x1,00	29,00	D	150 x 28 x 22 x 18	164,01	189,65		221,11
M 30x1,50	28,50	D	150 x 28 x 22 x 18	133,66	147,07	177,23	168,80
M 30x2,00	28,00	D	150 x 28 x 22 x 18	165,44*	175,59		242,96
M 30x3,50	26,50	D	180 x 40 x 22 x 18	137,67*	151,36	166,08	165,73
M 32x1,00	31,00	D	150 x 28 x 22 x 18	388,93	412,98		
M 32x1,50	30,50	D	150 x 28 x 22 x 18	169,12	185,68	218,36	
M 32x2,00	30,00	D	150 x 28 x 22 x 18	207,81	318,20		
M 33x1,00	32,00	D	160 x 30 x 25 x 20	358,20			
M 33x1,50	31,50	D	160 x 30 x 25 x 20	190,54	202,09		235,21
M 33x2,00	31,00	D	160 x 30 x 25 x 20	312,29	319,21		389,52
M 33x3,50	29,50	D	180 x 40 x 25 x 20	165,44*	190,36		211,14
M 34x1,50	32,50	D	170 x 30 x 28 x 22	212,21	224,80		
M 34x2,00	32,00	D	160 x 30 x 28 x 22	446,29			
M 35x1,50	33,50	D	170 x 30 x 28 x 22	223,80	246,17		269,20
M 35x2,00	33,00	D	170 x 30 x 28 x 22	411,82	453,36		
M 36x1,50	34,50	D	170 x 30 x 28 x 22	204,35	241,59		292,44
M 36x2,00	34,00	D	170 x 30 x 28 x 22	276,01	286,90		
M 36x3,00	33,00	D	200 x 50 x 28 x 22	316,67	329,12		423,25
M 36x4,00	32,00	D	200 x 50 x 28 x 22	217,13*	232,62	270,20	258,53
M 38x1,50	36,50	D	170 x 30 x 28 x 22	217,85	245,46		
M 38x2,00	36,00	D	170 x 32 x 28 x 22	463,04	509,37		
M 39x1,50	37,50	D	170 x 32 x 32 x 24	342,33			
M 39x2,00	37,00	D	170 x 32 x 32 x 24	342,33			
M 39x3,00	36,00	D	200 x 47 x 32 x 24	447,05			
M 39x4,00	35,00	D	200 x 50 x 32 x 24	260,50	270,79		333,90
M 40x1,50	38,50	D	170 x 30 x 32 x 24	284,85	313,53		
M 40x2,00	38,00	D	170 x 30 x 32 x 24	343,23			
M 40x3,00	37,00	D	200 x 47 x 32 x 24	336,52	401,49		
M 42x1,50	40,50	D	170 x 30 x 32 x 24	310,81	303,76		
M 42x2,00	40,00	D	170 x 30 x 32 x 24	392,65			
M 42x3,00	39,00	D	200 x 45 x 32 x 24	392,65	470,20		
M 42x4,50	37,50	D	200 x 56 x 32 x 24	334,98	348,10		372,23
M 45x1,50	43,50	D	180 x 32 x 36 x 29	371,22	408,30		
M 45x2,00	43,00	D	180 x 32 x 36 x 29	454,65			
M 45x3,00	42,00	D	200 x 47 x 36 x 29	454,65			
M 45x4,50	40,50	D	220 x 58 x 36 x 29	365,91	402,48		
M 48x1,50	46,50	D	190 x 32 x 36 x 29	365,91			
M 48x2,00	46,00	D	190 x 32 x 36 x 29	591,25			
M 48x3,00	45,00	D	220 x 52 x 36 x 29	550,95			
M 48x5,00	43,00	D	250 x 65 x 36 x 29	449,97	494,94		
M 50x1,50	48,50	D	190 x 32 x 36 x 29	443,49			
M 52x1,50	50,50	D	190 x 32 x 40 x 32	433,24			
M 52x2,00	50,00	D	190 x 32 x 40 x 32	685,61			
M 52x3,00	49,00	D	225 x 50 x 40 x 32	704,62			
M 52x5,00	47,00	D	250 x 65 x 40 x 32	460,83	570,19		

* Check the price of left hand taps available in page 217.

* Vc: Cutting Speed (m/min)

HSSCo MACHINE TAPS

UNC

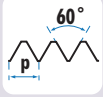
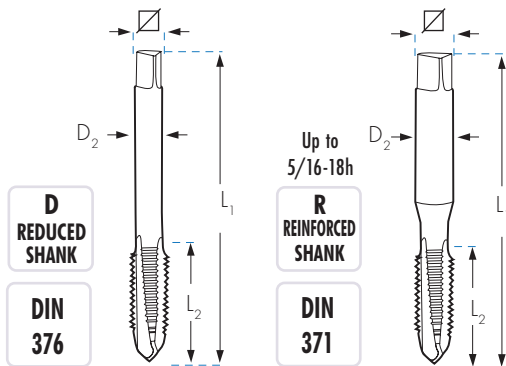
HSSCo
5%TOL
2BVc
12 m/min

	D1 mm	D2 mm	R	L1 x L2 x D2 x ∇ mm	MTR	M2R	M4R
					C FORM	B FORM	35°
					€	€	€
UNC n° 4-40h	2,84	2,25	R	56 x 11 x 3,5 x 2,7	25,64	30,49	34,79
UNC n° 5-40h	3,17	2,60	R	56 x 11 x 3,5 x 2,7	26,57	31,88	34,79
UNC n° 6-32h	3,50	2,75	R	56 x 12 x 4,0 x 3,0	25,29	30,39	34,64
UNC n° 8-32h	4,17	3,50	R	63 x 13 x 4,5 x 3,4	25,29	30,39	33,13
UNC n° 10-24h	4,83	3,90	R	70 x 15 x 6,0 x 4,9	26,57	31,88	36,39
UNC n° 12-24h	5,49	4,50	R	80 x 16 x 6,0 x 4,9	27,88	31,88	33,40
UNC 1/4-20h	6,35	5,10	R	80 x 17 x 7,0 x 5,5	24,84	27,08	31,25
UNC 5/16-18h	7,94	6,60	R	90 x 20 x 8,0 x 6,2	28,11	30,99	35,29

REDUCED SHANK STANDARD PITCH				MTD	M2D	M4D	
			D				
				€	€	€	
UNC 3/8-16h	9,52	8,00	D	100 x 22 x 7,0 x 5,5	32,05	33,61	37,77
UNC 7/16-14h	11,11	9,40	D	100 x 22 x 8,0 x 6,2	44,11	44,26	55,35
UNC 1/2-13h	12,70	10,75	D	110 x 24 x 9,0 x 7,0	47,87	53,04	60,54
UNC 9/16-12h	14,28	12,20	D	110 x 26 x 11,0 x 9,0	65,80	72,25	82,19
UNC 5/8-11h	15,87	13,50	D	110 x 27 x 12,0 x 9,0	63,93	70,36	79,93
UNC 3/4-10h	19,05	16,50	D	125 x 30 x 14,0 x 11,0	84,64	93,05	105,87
UNC 7/8-9h	22,22	19,50	D	140 x 32 x 18,0 x 14,5	111,37	122,36	165,66
UNC 1"-8h	25,40	22,25	D	160 x 36 x 18,0 x 14,5	147,16	160,76	207,81
UNC 1.1/8-7h	28,57	25,00	D	180 x 40 x 22,0 x 18,0	192,22		232,19
UNC 1.1/4-7h	31,75	28,00	D	180 x 40 x 22,0 x 18,0	225,30		297,04
UNC 1.3/8-6h	34,92	30,75	D	200 x 50 x 28,0 x 22,0	336,06		
UNC 1.1/2-6h	38,10	34,00	D	200 x 50 x 32,0 x 24,0	381,64		

* Vc: Cutting Speed (m/min)

HSSCo MACHINE TAPS

UNF

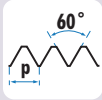

HSSCo
5%

TOL
2B

Vc
12 m/min

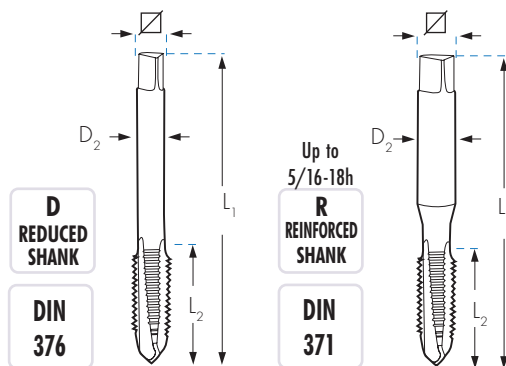

UNF n°	D ₁ mm	D ₂ mm	R	L ₁ × L ₂ × D ₂ × √ mm	M1R	M2R	M4R
					C FORM €	B FORM €	35° €
UNF n° 4-48h	2,84	2,35	R	56 × 11 × 3,5 × 2,7	26,84	29,22	36,68
UNF n° 5-44h	3,17	2,70	R	56 × 11 × 3,5 × 2,7	26,84	29,22	36,68
UNF n° 6-40h	3,50	2,95	R	56 × 12 × 4,0 × 3,0	25,67	30,74	36,40
UNF n° 8-36h	4,17	3,50	R	63 × 13 × 4,5 × 3,4	25,67	30,74	36,40
UNF n° 10-32h	4,83	4,10	R	70 × 15 × 6,0 × 4,9	25,67	30,74	36,40
UNF n° 12-28h	5,49	4,60	R	80 × 16 × 6,0 × 4,9	26,84	32,16	36,68
UNF 1/4-28h	6,35	5,50	R	80 × 17 × 7,0 × 5,5	21,68	23,22	27,09
UNF 5/16-24h	7,94	6,90	R	90 × 20 × 8,0 × 6,2	24,24	26,72	31,24

REDUCED SHANK STANDARD PITCH				M1D	M2D	M4D	
UNF 3/8-24h	9,52	8,50	D	90 × 16 × 7,0 × 5,5	26,54	30,70	39,08
UNF 7/16-20h	11,11	9,90	D	100 × 22 × 8,0 × 6,2	32,74	37,95	50,10
UNF 1/2-20h	12,70	11,50	D	100 × 22 × 9,0 × 7,0	34,86	40,35	53,30
UNF 9/16-18h	14,29	12,90	D	100 × 22 × 11,0 × 9,0	42,83	49,60	66,00
UNF 5/8-18h	15,87	14,50	D	100 × 22 × 12,0 × 9,0	48,22	55,79	73,74
UNF 3/4-16h	19,05	17,50	D	110 × 25 × 14,0 × 11,0	61,70	71,45	94,32
UNF 7/8-14h	22,22	20,40	D	125 × 25 × 18,0 × 14,5	77,59	97,06	144,28
UNF 1"-12h	25,40	23,25	D	140 × 28 × 18,0 × 14,5	116,79	127,17	169,81
UNS 1"-14h	25,40	23,60	D	140 × 28 × 18,0 × 14,5	117,31	130,82	169,82
UNF 1.1/8-12h	28,57	26,50	D	150 × 28 × 22,0 × 18,0	177,95		
UNF 1.1/4-12h	31,75	29,50	D	150 × 28 × 22,0 × 18,0	224,88		
UNF 1.1/2-12h	38,10	36,00	D	170 × 30 × 32,0 × 24,0	377,42		

* Vc: Cutting Speed (m/min)

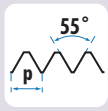
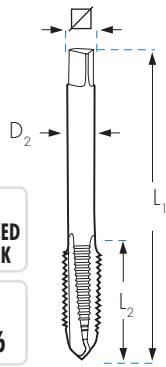
HSSCo MACHINE TAPS
**BSP
(GAS)**

**HSSCo
5%**
**TOL
ISO 228**
INOX

**Vc
12 m/min**

**Vc
6 m/min**

	D1 mm	D2	L1 x L2 x D2 x ∇ mm	M1D		M2D		M3D		M4D		M2DX		M4DX	
				C FORM	B FORM	B FORM	B FORM	15°	35°	B FORM	B FORM	35°			
				€	€	€	€	€	€	€	€	€	€	€	€
G 1/8-28h.	9,728	8,80	D 90 x 16 x 7 x 5,5	33,94*	38,77	39,72	41,16	59,93	59,31						
G 1/4-19h.	13,157	11,80	D 100 x 22 x 11 x 9,0	47,07*	51,82	57,04	59,11	80,74	86,42						
G 3/8-19h.	16,662	15,25	D 100 x 22 x 12 x 9,0	56,36*	62,01	68,13	70,59	95,79	101,56						
G 1/2-14h.	20,955	19,00	D 125 x 25 x 16 x 12,0	71,23*	78,38	85,93	89,02	118,60	128,19						
G 5/8-14h.	22,911	21,00	D 125 x 25 x 18 x 14,5	88,76*	93,09	106,99	106,00								
G 3/4-14h.	26,441	24,50	D 140 x 28 x 20 x 16,0	111,49	122,71	134,50	139,36	179,20	197,70						
G 7/8-14h.	30,201	28,25	D 150 x 28 x 22 x 18,0	149,87	157,66	180,90	179,21								
G 1"-11h.	33,249	30,75	D 160 x 30 x 25 x 20,0	173,06	190,32	206,53	214,00								
G 1.1/8-11h.	37,897	35,50	D 170 x 30 x 28 x 22,0	276,34	301,43		331,06								
G 1.1/4-11h.	41,910	39,50	D 170 x 30 x 32 x 24,0	324,25	341,16		377,68								
G 1.3/8-11h.	44,323	42,00	D 180 x 32 x 36 x 29,0	387,73			524,62								
G 1.1/2-11h.	47,803	45,25	D 190 x 32 x 36 x 29,0	517,04	720,77		682,81								
G 1.3/4-11h.	53,746	51,25	D 190 x 32 x 40 x 32,0	614,56	710,98										
G 2"-11h.	59,614	57,00	D 220 x 36 x 45 x 35,0	783,81	780,18										

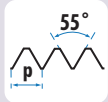
* Also available in left-hand cutting: double the standard price

* Vc: Cutting Speed (m/min)

BSF

**HSSCo
5%**
**TOL
ISO 228**
**Vc
12 m/min**
**D
REDUCED
SHANK**
**DIN
5156**

	D1 mm	D2	L1 x L2 x D2 x ∇ mm	M1D	
				C FORM	€
BSF 3/16-32h.	4,762	4,00	D 70 x 16 x 3,5 x 2,7		77,66
BSF 1/4-26h.	6,350	5,20	D 80 x 17 x 4,5 x 3,4		33,98
BSF 5/16-22h.	7,938	6,60	D 90 x 20 x 6,0 x 4,9		40,35
BSF 3/8-20h.	9,525	8,10	D 100 x 22 x 7,0 x 5,5		42,42
BSF 7/16-18h.	11,113	9,50	D 100 x 22 x 8,0 x 6,2		57,17
BSF 1/2-16h.	12,700	11,00	D 110 x 24 x 9,0 x 7,0		64,70
BSF 9/16-16h.	14,287	12,50	D 110 x 25 x 11,0 x 9,0		68,48
BSF 5/8-14h.	15,876	14,00	D 110 x 27 x 12,0 x 9,0		91,27
BSF 3/4-12h.	19,051	16,50	D 125 x 30 x 14,0 x 11,0		108,04
BSF 7/8-11h.	22,226	19,50	D 140 x 32 x 18,0 x 14,5		150,15
BSF 1"-10h.	25,400	22,50	D 160 x 36 x 18,0 x 14,5		174,54

* Vc: Cutting Speed (m/min)

HSSCo MACHINE TAPS

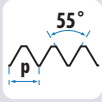
BSW



HSSCo
5%

TOL 2
Class

Vc
12 m/min

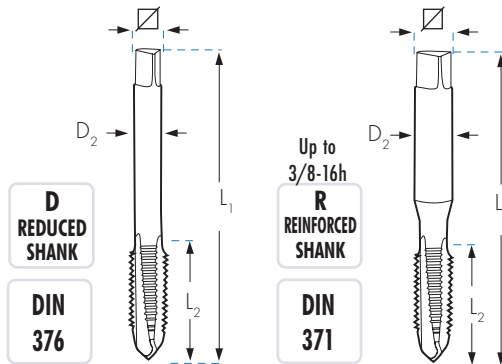



	D1 mm		L1 x L2 x D2 x	M1R	M2R	M3R	M4R
				C FORM	B FORM	15°	35°
				€	€	€	€
W 3/32-48h.	2,38	1,80	R 50 x 9 x 2,8 x 2,1	23,59	25,18		
W 1/8-40h.	3,17	2,55	R 56 x 11 x 3,5 x 2,7	19,68*	21,75	25,68	24,71
W 5/32-32h.	3,97	3,10	R 63 x 13 x 4,5 x 3,4	19,68	21,75	25,68	24,71
W 3/16-24h.	4,76	3,60	R 70 x 15 x 6,0 x 4,9	21,84	21,75	25,68	24,71
W 7/32-24h.	5,56	4,40	R 80 x 16 x 6,0 x 4,9	29,88	31,59		
W 1/4-20h.	6,35	5,10	R 80 x 17 x 7,0 x 5,5	21,02	24,71	29,15	30,20
W 5/16-18h.	7,94	6,50	R 90 x 20 x 8,0 x 6,2	23,57	31,16	34,02	33,96
W 3/8-16h.	9,52	7,90	R 100 x 22 x 10,0 x 8,0	26,38	34,44	37,81	37,75

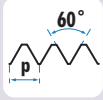
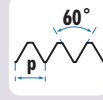
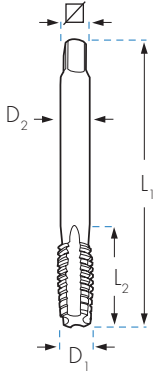
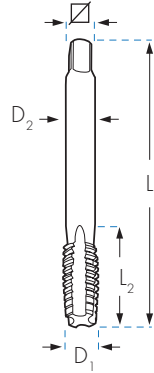

REDUCED SHANK STANDARD PITCH				M1D	M2D	M3D	M4D
W 7/16-14h.	11,11	9,25	D 100 x 22 x 8,0 x 6,2	36,69	37,93	47,66	48,00
W 1/2-12h.	12,70	10,50	D 110 x 24 x 9,0 x 7,0	35,18	39,55	45,66	45,99
W 9/16-12h.	14,29	12,00	D 110 x 26 x 11,0 x 9,0	50,43	52,37	65,49	65,95
W 5/8-11h.	15,87	13,40	D 110 x 27 x 12,0 x 9,0	47,75	49,48	61,93	62,36
W 3/4-10h.	19,05	16,50	D 125 x 30 x 14,0 x 11,0	66,83	69,37	82,97	83,56
W 7/8-9h.	22,22	19,25	D 140 x 32 x 18,0 x 14,5	86,56	89,76	112,31	108,15
W 1"-8h.	25,40	21,75	D 160 x 36 x 18,0 x 14,5	108,79	112,82	140,94	141,94
W 1.1/8-7h.	28,57	24,75	D 180 x 40 x 22,0 x 18,0	147,54	168,11	202,14	
W 1.1/4-7h.	31,75	27,75	D 180 x 40 x 22,0 x 18,0	214,33	244,27		
W 1.3/8-6h.	34,92	30,50	D 200 x 50 x 28,0 x 22,0	352,29	401,13		
W 1.1/2-6h.	38,10	33,50	D 200 x 50 x 32,0 x 24,0	382,38	435,79		
W 1.5/8-5h.	41,27	46,50	D 220 x 65 x 32,0 x 24,0	533,73	608,30		
W 1.3/4-5h.	44,45	39,00	D 220 x 58 x 36,0 x 29,0	571,69	656,25		
W 1.7/8-4,5h.	47,62	42,00	D 250 x 75 x 36,0 x 29,0	662,89	727,51		
W 2"-4,5h.	50,80	44,50	D 250 x 65 x 40,0 x 32,0	818,21			

* Also available in left-hand cutting: double the standard price

* Vc: Cutting Speed (m/min)

HSSCo MACHINE TAPS
UNJC

HSSCo
5%
TOL
3B
UNJF

HSSCo
5%
TOL
3B
Vc
12 m/min

Vc
12 m/min

	D1 mm		L1 x L2 x D2 x ∇ mm	MIR
				C FORM €
UNJC n° 4-40h	2,84	2,25	R 56 x 11 x 3,5 x 2,7	38,94
UNJC n° 5-40h	3,17	2,60	R 56 x 11 x 3,5 x 2,7	38,94
UNJC n° 6-32h	3,50	2,75	R 56 x 12 x 4,0 x 3,0	38,94
UNJC n° 8-32h	4,17	3,50	R 63 x 13 x 4,5 x 3,4	38,94
UNJC n°10-24h	4,83	3,90	R 70 x 15 x 6,0 x 4,9	38,94
UNJC n°12-24h	5,49	4,50	R 80 x 16 x 6,0 x 4,9	40,85
UNJC 1/4-20h	6,35	5,10	R 80 x 17 x 7,0 x 5,5	36,34
UNJC 5/16-18h	7,94	6,60	R 90 x 20 x 8,0 x 6,2	41,12
UNJC 3/8-16h	9,52	8,00	R 100 x 22 x 8,0 x 6,2	46,88

	D1 mm		L1 x L2 x D2 x ∇ mm	MIR
				C FORM €
UNJF n° 4-48h	2,84	2,35	R 56 x 11 x 3,5 x 2,7	42,72
UNJF n° 5-44h	3,17	2,70	R 56 x 11 x 3,5 x 2,7	42,72
UNJF n° 6-40h	3,50	2,95	R 56 x 12 x 4,0 x 3,0	42,72
UNJF n° 8-36h	4,17	3,50	R 63 x 13 x 4,5 x 3,4	42,72
UNJF n°10-32h	4,83	4,10	R 70 x 15 x 6,0 x 4,9	42,72
UNJF n°12-28h	5,49	4,60	R 80 x 16 x 6,0 x 4,9	42,72
UNJF 1/4-28h	6,35	5,50	R 80 x 17 x 7,0 x 5,5	33,17
UNJF 5/16-24h	7,94	6,90	R 90 x 20 x 8,0 x 6,2	37,09
UNJF 3/8-24h	9,52	8,50	R 90 x 16 x 7,0 x 6,2	40,61

REDUCED SHANK STANDARD PITCH				M1D
UNJC 7/16-14h	11,11	9,40	D 110 x 24 x 9,0 x 7,0	64,65
UNJC 1/2-13h	12,70	10,75	D 110 x 26 x 11,0 x 9,0	70,17
UNJC 9/16-12h	14,28	12,20	D 110 x 27 x 12,0 x 9,0	96,45
UNJC 5/8-11h	15,87	13,50	D 110 x 27 x 12,0 x 9,0	98,87
UNJC 3/4-10h	19,05	16,50	D 125 x 30 x 14,0 x 11,0	124,05
UNJC 7/8-9h	22,22	19,50	D 140 x 32 x 18,0 x 14,5	163,23
UNJC 1"-8h	25,40	22,25	D 160 x 36 x 18,0 x 14,5	215,66

REDUCED SHANK STANDARD PITCH				M1D
UNJF 7/16-20h	11,11	9,90	D 100 x 22 x 8,0 x 6,2	55,77
UNJF 1/2-20h	12,70	11,50	D 100 x 22 x 9,0 x 7,0	59,39
UNJF 9/16-18h	14,29	12,90	D 100 x 22 x 11,0 x 9,0	72,97
UNJF 5/8-18h	15,87	14,50	D 100 x 22 x 12,0 x 9,0	82,15
UNJF 3/4-16h	19,05	17,50	D 110 x 25 x 14,0 x 11,0	105,10
UNJF 7/8-14h	22,22	20,40	D 125 x 25 x 18,0 x 14,5	132,16
UNJF 1"-12h	25,40	23,25	D 140 x 28 x 18,0 x 14,5	147,35

* Vc: Cutting Speed (m/min)

HSSCo MACHINE TAPS

BSP **DIN 2999** **55°** **HSSCo 5%** **DIN 374** **C FORM**

BSPT **BS21 ISO7/1** **55°** **HSSCo 5%** **DIN 5156** **C FORM**

BRITISH STANDARD PIPE

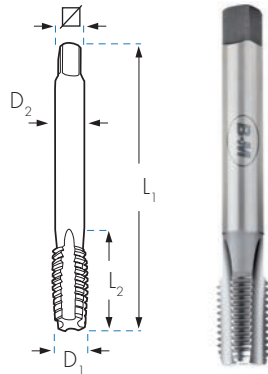

BRITISH STANDARD TAPER PIPE

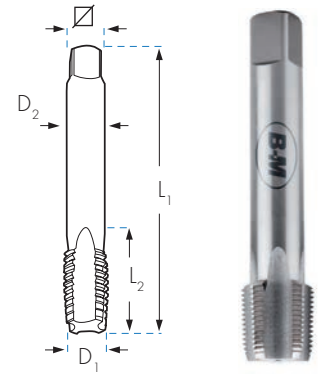

	D1 mm	L1 x L2 x D2 x ∅ mm	MTD	€
Rp 1/16-28h.	7,72	D 90 x 16 x 6 x 4,9		
Rp 1/8-28h.	9,73	D 90 x 16 x 7 x 5,5		50,65
Rp 1/4-19h.	13,16	D 100 x 22 x 11 x 9,0		69,96
Rp 3/8-19h.	16,66	D 100 x 22 x 12 x 9,0		83,77
Rp 1/2-14h.	20,95	D 125 x 25 x 16 x 12,0		105,87
Rp 3/4-14h.	26,44	D 140 x 28 x 20 x 16,0		165,78
Rp 1"-11h.	33,25	D 160 x 30 x 25 x 20,0		257,22
Rp 1.1/4-11h.	41,91	D 170 x 30 x 32 x 24,0		
Rp 1.1/2-11h.	46,80	D 190 x 32 x 36 x 29,0		
Rp 2"-11h.	59,61	D 220 x 36 x 45 x 35,0		

	D1 mm	∅	L1 x L2 x D2 x ∅ mm	MTD	€
Rc 1/16-28h.	7,72		D 90 x 14 x 6 x 4		
Rc 1/8-28h.	9,73	8,30	D 90 x 15 x 7 x 5		51,82
Rc 1/4-19h.	13,16	11,00	D 100 x 19 x 11 x 9		74,53
Rc 3/8-19h.	16,66	14,50	D 100 x 21 x 12 x 9		103,58
Rc 1/2-14h.	20,95	18,10	D 125 x 26 x 16 x 12		143,92
Rc 5/8-14h.	22,91	21,00	D 140 x 36 x 18 x 19		232,16
Rc 3/4-14h.	26,44	23,50	D 140 x 28 x 20 x 16		224,47
Rc 7/8-14h.	30,20	28,25	D 160 x 36 x 22 x 18		390,60
Rc 1"-11h.	33,25	29,60	D 160 x 33 x 25 x 20		321,71

NPS (M) **ANSI B 1.20.1** **60°** **HSSCo 5%** **DIN 374** **C FORM**

NPT **ANSI B 1.20.1** **60°** **HSSCo 5%** **DIN 374** **C FORM**

NATIONAL STRAIGHT PIPE MECHANICAL

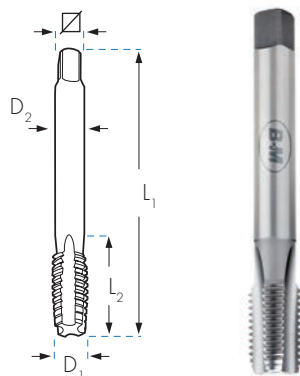

NATIONAL TAPER PIPE

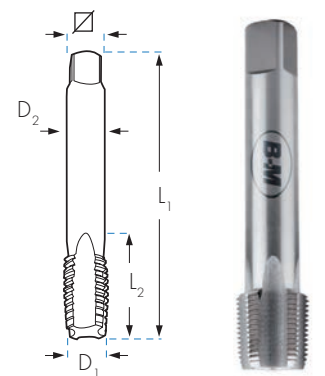

	D1 mm	∅	L1 x L2 x D2 x ∅ mm	MTD	€
NPS 1/8-27h.	10,20	8,90	D 90 x 16 x 7 x 5,5		130,46
NPS 1/4-18h.	13,60	11,70	D 100 x 22 x 11 x 9,0		186,72
NPS 3/8-18h.	17,00	15,00	D 100 x 22 x 12 x 9,0		256,05
NPS 1/2-14h.	21,20	18,60	D 125 x 25 x 16 x 12,0		351,11
NPS 3/4-14h.	26,55	24,00	D 140 x 28 x 20 x 16,0		519,05
NPS 1"-11,5 h.	33,20	30,00	D 160 x 30 x 25 x 20,0		671,23
NPS 1.1/4-11,5h.	41,60		D 170 x 30 x 32 x 24,0		
NPS 1.1/2-11,5h.	47,68		D 190 x 32 x 36 x 29,0		
NPS 2"-11,5h.	59,71		D 220 x 36 x 45 x 35,0		

	D1 mm	∅	L1 x L2 x D2 x ∅ mm	MTD	€
NPT 1/16-27h.	7,89	6,2	D 90 x 14 x 6 x 5		45,39
NPT 1/8-27h.	10,24	8,5	D 90 x 15 x 8 x 6		47,47
NPT 1/4-18h.	13,62	11,0	D 100 x 19 x 11 x 9		61,30
NPT 3/8-18h.	17,05	14,5	D 100 x 21 x 12 x 9		78,80
NPT 1/2-14h.	21,22	17,8	D 125 x 26 x 16 x 12		102,51
NPT 3/4-14h.	26,57	23,0	D 140 x 28 x 20 x 16		158,83
NPT 1"-11,5h.	33,23	29,0	D 160 x 33 x 25 x 20		206,44
NPT 1.1/4-11,5h.	41,98	37,5	D 170 x 36 x 32 x 24		281,86
NPT 1.1/2-11,5h.	48,05	44,0	D 190 x 37 x 36 x 29		443,82
NPT 2"-11,5h.	60,09	56,0	D 220 x 41 x 45 x 35		696,18

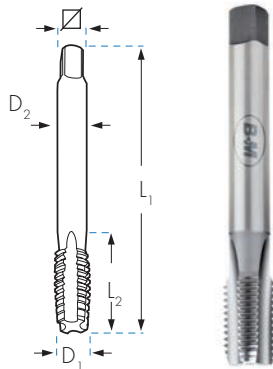
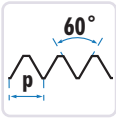
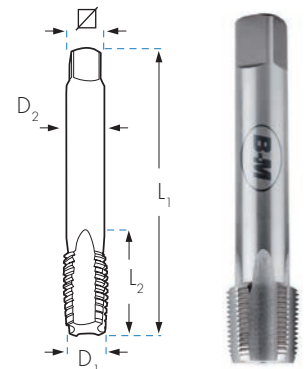
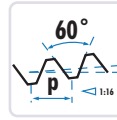
HSSCo MACHINE TAPS
NPSF
HSSCo
5%
DIN
374
C
FORM

NATIONAL STRAIGHT
PIPE DRYSEAL
NPTF
HSSCo
5%
DIN
374
C
FORM

NATIONAL TAPER
PIPE DRYSEAL

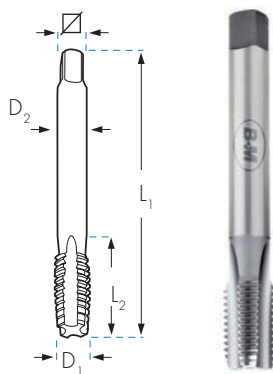
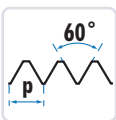
			D1 mm			L1 x L2 x D2 x \square mm	M1D €
NPSF 1/8-27h.	10,05	8,75	D	90 x 16 x 7 x 5,5	163,42		
NPSF 1/4-18h.	13,33	11,30	D	100 x 22 x 11 x 9,0	225,25		
NPSF 3/8-18h.	16,78	14,70	D	100 x 22 x 12 x 9,0	320,44		
NPSF 1/2-14h.	20,87	18,20	D	125 x 25 x 16 x 12,0	399,60		
NPSF 3/4-14h.	26,23	23,50	D	140 x 28 x 20 x 16,0	654,00		
NPSF 1"-11,5h.	32,81	29,50	D	160 x 30 x 25 x 20,0			

			D1 mm			L1 x L2 x D2 x \square mm	M1D €
NPTF 1/16-27h.	7,87	6,20	D	90 x 14 x 12,0 x 6			
NPTF 1/8-27h.	10,22	8,50	D	90 x 15 x 12,0 x 7	110,41		
NPTF 1/4-18h.	13,58	11,00	D	100 x 21 x 17,5 x 11	154,90		
NPTF 3/8-18h.	17,02	14,50	D	110 x 21 x 17,6 x 12	198,99		
NPTF 1/2-14h.	21,21	17,80	D	140 x 27 x 22,8 x 16	259,05		
NPTF 3/4-14h.	26,56	23,00	D	140 x 27 x 23,0 x 20	401,32		

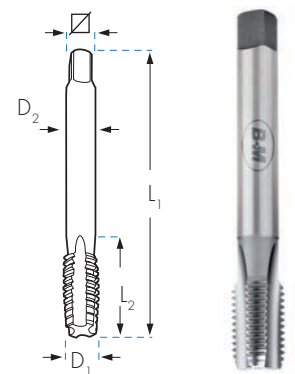
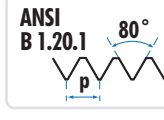
MF
HSSCo
5%
TOL
6H
C
FORM
DIN
374

METRIC FINE FOR ELECTRICIAN PIPE
NORM EN 60423

			D1 mm			L1 x L2 x D2 x \square mm	M1D €
MF 12 x 1,50	12	10,5	D	100 x 22 x 9 x 7,0	27,86		
MF 16 x 1,50	16	14,5	D	100 x 22 x 12 x 9,0	39,23		
MF 20 x 1,50	20	18,5	D	125 x 25 x 16 x 12,0	58,83		
MF 25 x 1,50	25	23,5	D	140 x 28 x 18 x 14,5	135,50		
MF 32 x 1,50	32	30,5	D	150 x 28 x 22 x 18,0	169,12		
MF 40 x 1,50	40	38,5	D	170 x 30 x 32 x 24,0	284,85		
MF 50 x 1,50	50	48,5	D	190 x 32 x 36 x 29,0	443,49		
MF 63 x 1,50	63	61,5	D	275 x 36 x 50 x 39,0			

PG
HSSCo
5%
DIN
40430
C
FORM

ARMOUR PIPE
STEEL CONDUIT

			D1 mm			L1 x L2 x D2 x \square mm	M1D €
PG 7 - 20h.	12,5	11,50	D	100 x 22 x 9 x 7,0	48,45		
PG 9 - 18h.	15,2	14,00	D	100 x 22 x 12 x 9,0	67,10		
PG 11 - 18h.	18,6	17,25	D	110 x 25 x 14 x 11,0	87,30		
PG 13,5 - 18h.	20,4	19,00	D	125 x 25 x 16 x 12,0	98,04		
PG 16 - 18h.	22,5	21,25	D	125 x 25 x 18 x 14,5	115,38		
PG 21 - 16h.	28,3	27,00	D	150 x 28 x 22 x 18,0	183,17		
PG 29 - 16h.	37,0	35,50	D	170 x 30 x 28 x 22,0	309,65		
PG 36 - 16h.	47,0	45,50	D	190 x 32 x 36 x 29,0	502,89		
PG 42 - 16h.	54,0	52,50	D	190 x 32 x 40 x 32,0	798,67		
PG 48 - 16h.	59,3	58,00	D	220 x 36 x 45 x 35,0	973,64		

HSSCo MACHINE TAPS

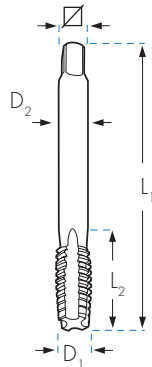
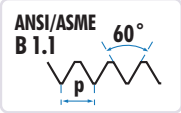
UNx8 HSSCo 5% DIN 374 C FORM TOL 2B



UNEF HSSCo 5% DIN 374 TOL 2B

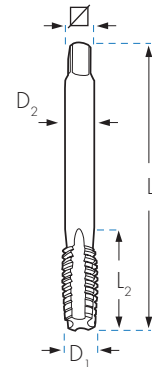
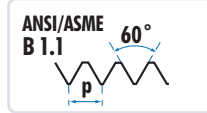

		D ₂ mm	L ₁ x L ₂ x mm	M1D C FORM €
UN 1" 1/8-8h.	25,40	22	180 x 45 x 18	240,85
UN 1" 1/4-8h.	28,50	22	180 x 48 x 18	310,74
UN 1" 3/8-8h.	31,75	28	200 x 56 x 22	352,49
UN 1" 1/2-8h.	35,00	32	200 x 58 x 22	448,49
UN 1" 5/8-8h.	38,10	32	200 x 65 x 24	524,62
UN 1" 3/4-8h.	41,25	36	200 x 50 x 29	639,07
UN 1" 7/8-8h.	44,45	36	225 x 53 x 29	737,18
UN 2"-8h.	47,63	40	225 x 50 x 32	753,23

		D ₂ mm	L ₁ x L ₂ x mm	M2D B FORM €	M4D 35° €
UNEF 1/4-32h.	5,55	7,0	R 82 x 16 x 5,4	99,66	112,00
UNEF 5/16-32h.	7,15	8,4	R 85 x 21 x 6,1	109,81	123,38
UNEF 3/8-32h.	8,70	7,0	D 95 x 22 x 5,4	109,87	123,45
UNEF 7/16-28h.	10,20	8,0	D 100 x 22 x 6,2	145,83	163,85
UNEF 1/2-28h.	11,80	9,0	D 100 x 22 x 7,0	153,60	172,59
UNEF 9/16-24h.	13,20	12,0	D 100 x 24 x 9,0	192,44	216,23
UNEF 5/8-24h.	14,80	12,0	D 100 x 24 x 9,0	218,99	246,06
UNEF 3/4-20h.	17,80	14,0	D 110 x 27 x 11,0	284,81	320,04
UNEF 7/8-20h.	20,95	18,0	D 125 x 26 x 14,5	306,15	328,02
UNEF 1"-20h.	24,20	18,0	D 140 x 28 x 14,5	468,51	526,42

HSSCo MACHINE TAPS LEFT-HAND

M MF HSSCo 5% C FORM TOL 6H

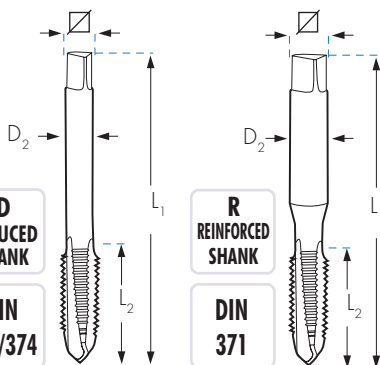
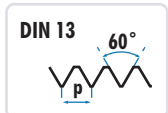





			L ₁ x L ₂ x D ₂ x mm	M1R1 C FORM €
M 3x0,50	2,50	R	56 x 11 x 3,5 x 2,7	22,66
M 4x0,70	3,30	R	63 x 13 x 4,5 x 3,4	25,79
M 5x0,80	4,20	R	70 x 16 x 6,0 x 4,9	23,09
M 6x1,00	5,00	R	80 x 17 x 6,0 x 4,9	26,27
M 7x1,00	6,00	R	80 x 17 x 7,0 x 5,5	34,07
M 8x1,25	6,80	R	90 x 20 x 8,0 x 6,2	29,68
M 10x1,50	8,50	R	100 x 22 x 10,0 x 8,0	33,64

REDUCED SHANK STANDARD PITCH			M1D1	
M 12x1,50	10,50	D	100 x 22 x 9,0 x 7,0	55,72
M 12x1,75	10,20	D	110 x 24 x 9,0 x 7,0	40,15
M 14x1,50	12,50	D	100 x 22 x 11,0 x 9,0	66,36
M 14x2,00	12,00	D	110 x 26 x 11,0 x 9,0	65,92
M 16x1,50	14,50	D	100 x 22 x 12,0 x 9,0	78,46
M 16x2,00	14,00	D	110 x 27 x 12,0 x 9,0	77,59
M 18x1,50	16,50	D	110 x 25 x 14,0 x 11,0	103,88
M 18x2,50	15,50	D	125 x 30 x 14,0 x 11,0	111,62
M 20x1,50	18,50	D	125 x 25 x 16,0 x 12,0	117,65
M 20x2,50	17,50	D	140 x 32 x 16,0 x 12,0	118,81
M 22x2,50	19,50	D	140 x 32 x 18,0 x 14,5	143,77
M 24x2,00	22,00	D	140 x 28 x 18,0 x 14,5	222,23
M 24x3,00	21,00	D	160 x 34 x 18,0 x 14,5	172,11
M 27x3,00	24,00	D	160 x 36 x 20,0 x 16,0	214,86
M 30x2,00	28,00	D	150 x 28 x 22,0 x 18,0	330,88
M 30x3,50	26,50	D	180 x 40 x 22,0 x 18,0	275,33
M 33x3,50	29,50	D	180 x 40 x 25,0 x 20,0	330,88
M 36x4,00	32,00	D	200 x 50 x 28,0 x 22,0	434,27

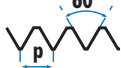
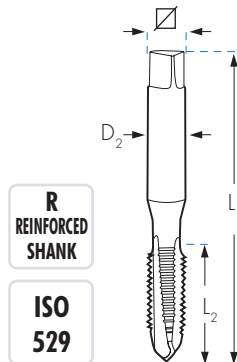
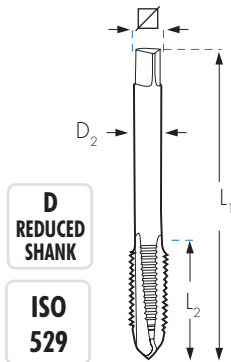
Check other dimensions upon request

* Vc: Cutting Speed (m/min)

HSSCo MACHINE TAPS ISO 529
M
MF
DIN 13

HSSCo
5%
ISO
529
TOL
6H

		$L_1 \times L_2 \times D_2 \times \square$ mm	M1RISO	M2RISO	M4RISO	M5RISO
			C FORM	B FORM	 35°	INTERRUPTED THREAD AI
			€	€	€	€
M 3x0,50	2,50	R 48 x 11 x 3,15 x 2,50	8,17	8,52	10,26	12,20
M 4x0,70	3,30	R 53 x 13 x 4,00 x 3,15	8,17	8,52	10,26	12,20
M 5x0,80	4,20	R 58 x 16 x 5,00 x 4,00	8,17	8,52	10,26	12,20
M 6x1,00	5,00	R 66 x 19 x 6,30 x 5,00	8,17	8,52	10,48	12,20
M 7x1,00	6,00	R 66 x 19 x 7,10 x 5,60		12,12	13,91	
M 8x1,00	7,00	R 69 x 19 x 8,00 x 6,30		16,72	17,16	
M 8x1,25	6,75	R 72 x 22 x 8,00 x 6,30	10,92	11,37	11,76	13,33
M 9x1,25	7,75	R 76 x 20 x 10,00 x 8,00		18,09	20,66	
M 10x1,00	9,00	R 76 x 20 x 10,00 x 8,00		19,18	20,95	
M 10x1,25	8,80	R 76 x 20 x 10,00 x 8,00		22,93	23,67	
M 10x1,50	8,50	R 80 x 24 x 10,00 x 8,00	13,89	14,47	15,16	16,82
REDUCED SHANK			M1DISO	M2DISO	M4DISO	M5DISO
M 12x1,00	11,00	D 84 x 24 x 9,00 x 7,10		26,42	27,07	
M 12x1,25	10,75	D 84 x 24 x 9,00 x 7,10		25,95	26,87	
M 12x1,50	10,50	D 89 x 29 x 9,00 x 7,10		23,15	24,93	
M 12x1,75	10,20	D 89 x 29 x 9,00 x 7,10	17,85	18,59	19,69	25,16
M 14x1,00	13,00	D 90 x 25 x 11,20 x 9,00		33,09	41,16	
M 14x1,25	12,80	D 90 x 25 x 11,20 x 9,00		27,94	34,99	
M 14x1,50	12,50	D 95 x 30 x 12,50 x 9,00		24,55	27,59	
M 14x2,00	12,00	D 95 x 30 x 11,20 x 9,00	21,34	22,23	26,91	
M 16x1,00	15,00	D 95 x 25 x 12,50 x 10,00		42,10	54,18	
M 16x1,25	14,75	D 102 x 32 x 12,50 x 10,00		46,68	60,08	
M 16x1,50	14,50	D 102 x 32 x 14,00 x 10,00		29,47	33,02	
M 16x2,00	14,00	D 102 x 32 x 12,50 x 10,00	26,50	27,60	31,22	
M 18x1,50	16,50	D 104 x 29 x 14,00 x 11,20		38,93	53,20	
M 18x2,50	15,50	D 112 x 37 x 14,00 x 11,20	39,90	41,56	51,96	
M 20x1,50	18,50	D 104 x 29 x 14,00 x 11,20		50,10	61,28	
M 20x2,50	17,50	D 112 x 37 x 14,00 x 11,20	44,60	46,46	58,07	
M 22x2,50	19,50	D 118 x 38 x 16,00 x 12,50	51,57	53,72	67,15	
M 24x3,00	21,00	D 130 x 45 x 18,00 x 14,00	58,26	60,69	75,85	
M 27x3,00	24,00	D 135 x 45 x 20,00 x 16,00	71,74	74,73	93,42	
M 30x3,50	26,50	D 138 x 48 x 20,00 x 16,00	106,59	111,04	138,79	

MACHINE TAPS DIN 352

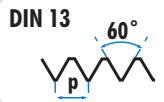
M
MF



HSS

HSSCo
5%

DIN
352

TOL
6H

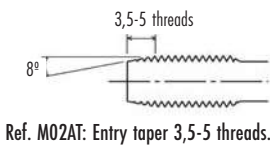
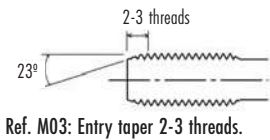

D
REDUCED
SHANK

DIN
352

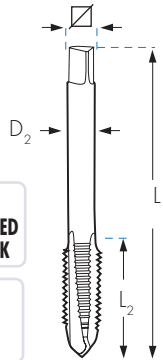

Icon	Icon	L ₁ x L ₂ x D ₂ x mm	M03	M02AT	M03X	M02DIN	M04DIN
			HSS €	COMPLETE PROFILE HSS €	INOX HSSCo €	B FORM HSS €	35° HSS €
M 3x0,50	2,50	D 40 x 11 x 3,50 x 2,70	7,36	9,93	13,14	9,37	11,29
M 4x0,70	3,30	D 45 x 13 x 4,50 x 3,40	7,35	9,92	13,14	9,37	11,29
M 5x0,80	4,20	D 50 x 16 x 6,00 x 4,90	7,86	10,62	13,68	9,37	11,29
M 6x1,00	5,00	D 50 x 19 x 6,00 x 4,90	7,86	10,62	13,63	9,37	11,53
M 7x1,00	6,00	D 50 x 19 x 6,00 x 4,90	9,58				
M 8x1,00	7,00	D 56 x 18 x 6,00 x 4,90	13,25				
M 8x1,25	6,75	D 56 x 22 x 6,00 x 4,90	9,57	12,92	15,87	12,51	13,98
M 9x1,25	7,75	D 63 x 18 x 7,00 x 5,50	15,67				
M 10x1,00	9,00	D 63 x 18 x 7,00 x 5,50	14,19				
M 10x1,25	8,80	D 70 x 24 x 7,00 x 5,50	14,38				
M 10x1,50	8,50	D 70 x 24 x 7,00 x 5,50	11,80	15,92	20,41	15,91	17,62
M 12x1,00	11,00	D 70 x 20 x 9,00 x 7,00	25,16				
M 12x1,25	10,75	D 70 x 20 x 9,00 x 7,00	25,08				
M 12x1,50	10,50	D 70 x 20 x 9,00 x 7,00	21,37				
M 12x1,75	10,20	D 75 x 29 x 9,00 x 7,00	16,60	22,42	29,23	20,46	22,94
M 14x1,00	13,00	D 70 x 20 x 11,00 x 9,00	39,21				
M 14x1,25	12,80	D 70 x 20 x 11,00 x 9,00	30,63				
M 14x1,50	12,50	D 70 x 20 x 11,00 x 9,00	23,82				
M 14x2,00	12,00	D 80 x 30 x 11,00 x 9,00	18,36	24,79	32,37	24,45	29,61
M 16x1,00	15,00	D 70 x 20 x 12,00 x 9,00	52,02				
M 16x1,25	14,75	D 70 x 20 x 12,00 x 9,00	54,75				
M 16x1,50	14,50	D 70 x 20 x 12,00 x 9,00	29,64				
M 16x2,00	14,00	D 80 x 32 x 12,00 x 9,00	26,27		44,37	30,37	34,33
M 18x1,50	16,50	D 80 x 22 x 14,00 x 11,00	39,05				
M 18x2,50	15,50	D 95 x 40 x 14,00 x 11,00	34,67		60,59	45,72	57,16
M 20x1,50	18,50	D 80 x 22 x 16,00 x 12,00	48,90				
M 20x2,50	17,50	D 95 x 40 x 16,00 x 12,00	38,89		67,26	51,10	63,88
M 22x2,50	19,50	D 100 x 40 x 18,00 x 14,50	51,81			59,08	73,87
M 24x3,00	21,00	D 110 x 50 x 18,00 x 14,50	61,79			66,76	83,44
M 27x3,00	24,00	D 110 x 50 x 20,00 x 16,00	78,14			86,17	94,59
M 30x3,50	26,50	D 125 x 50 x 22,00 x 18,00	100,53			118,03	121,22

Threading tools
Pink
Green

MACHINE TAPS AND DIES *Plus & Super Plus*

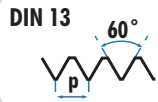

TOL
6H

FOR HIGH PRODUCTION WORKS
HSS PM: POWDER STEEL

DIN
22568

TOL
6g



Plus **Plus TiN** **Plus LUBE** **Super Plus ALTiN**

QUALITY	M2RP		M4RP		M2RT		M4RT		M2RHL		M4RHL		M2RSP		M4RSP		C5P	
	★ ★	★ ★	★ ★ ★	★ ★ ★	★ ★ ★ ★	★ ★ ★ ★	★ ★ ★ ★	★ ★ ★ ★	★ ★ ★ ★	★ ★ ★ ★	★ ★ ★ ★	★ ★ ★ ★	★ ★ ★ ★	★ ★ ★ ★	★ ★ ★ ★	★ ★ ★ ★		
MATERIAL	HSS PM		HSS PM		HSSCo 5%		HSSCo 5%		HSS PM		HSS PM		HSS V3		HSS V3		HSS	
COATING	BRIGHT		BRIGHT		TiN		TiN		HARD LUBE		HARD LUBE		ALTiN		ALTiN		BRIGHT	
HELIX ANGLE	B FORM		35°		B FORM		35°		B FORM		35°		B FORM		41°			
	L ₁ x L ₂ x D ₂ x ∅		€	€	€	€	€	€	€	€	€	€	€	€	€	€	∅ x L ₃ mm	€
M 3x0,50	2,50	R	56 x 11 x 3,5 x 2,7	16,75	20,70	22,55	24,92	30,20	32,69	40,58	42,47	25 x 9	30,82					
M 4x0,70	3,30	R	63 x 13 x 4,5 x 3,4	17,11	20,70	22,91	25,99	30,66	33,14	40,58	42,47	25 x 9	30,82					
M 5x0,80	4,20	R	70 x 16 x 6,0 x 4,9	17,11	19,84	22,91	25,99	30,66	33,14	42,86	44,05	25 x 9	30,82					
M 6x1,00	5,00	R	80 x 17 x 6,0 x 4,9	18,82	21,79	26,38	28,57	33,66	35,09	42,86	44,05	25 x 9	30,82					
M 8x1,00	7,00	D	90 x 20 x 6,0 x 4,9	26,86	31,87	37,82	42,09	51,06	56,83			25 x 9	42,98					
M 8x1,25	6,80	R	90 x 20 x 8,0 x 6,2	22,03	25,31	30,84	33,54	42,80	44,65	54,41	57,98	25 x 9	33,43					
M 10x1,00	9,00	D	90 x 16 x 7,0 x 5,5	29,94	37,54	44,18	50,72	59,62	70,44			30 x 10	52,53					
M 10x1,50	8,50	R	100 x 22 x 10,0 x 8,0	25,92	29,47	36,32	39,77	53,08	55,56	64,84	69,17	30 x 10	45,97					
REDUCED SHANK			M2DP	M4DP	M2DT	M4DT	M2DHL	M4DHL	M2DSP	M4DSP								
M 12x1,50	10,50	D	100 x 22 x 9,0 x 7,0	35,52	42,94	47,85	53,87	64,30	73,75			38 x 10	54,61					
M 12x1,75	10,20	D	110 x 24 x 9,0 x 7,0	33,41	39,68	44,78	50,49	56,03	67,25	81,58	88,50	38 x 14	48,22					
M 14x1,50	12,50	D	100 x 22 x 11,0 x 9,0	42,09	52,78	56,27	62,15	75,63	86,73			38 x 10	57,09					
M 14x2,00	12,00	D	110 x 26 x 11,0 x 9,0	41,77	48,42	55,26	60,75	76,43	84,01	83,29	112,14	38 x 14	49,15					
M 16x1,50	14,50	D	100 x 22 x 12,0 x 9,0	52,65	64,91	67,63	77,32	74,68	87,17			45 x 14	78,42					
M 16x2,00	14,00	D	110 x 27 x 12,0 x 9,0	49,12	58,52	63,09	69,74	87,26	96,44	113,69	120,94	45 x 18	66,03					
M 18x2,50	15,50	D	125 x 30 x 14,0 x 11,0	69,63	78,66	86,15	93,99	123,27	130,97	168,75	182,57	45 x 18	66,03					
M 20x2,50	17,50	D	140 x 32 x 16,0 x 12,0	75,23	83,85	98,19	105,78	129,51	147,46	179,85	190,10	45 x 18	66,03					
M 22x2,50	19,50	D	140 x 32 x 18,0 x 14,5	91,01	103,47	110,97	118,78	151,90	165,76			55 x 22	98,15					
M 24x3,00	21,00	D	160 x 34 x 18,0 x 14,5	108,21	123,87	125,04	135,87	171,16	189,59			55 x 22	98,15					

* Vc: Cutting Speed (m/min))

POWDER STEEL MACHINE TAPS FOR STAINLESS STEEL

INOX

M

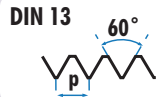

**TOL
6H**

**Vc
6 m/min**

**Vc
10 m/min**

**Vc
12 m/min**

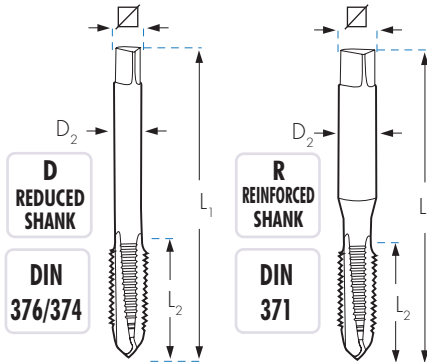

		M2RX	M4RX	M2RXT	M4RXT	M2RXHL	M4RXHL
QUALITY		★★	★★	★★★	★★★	★★★★	★★★★
MATERIAL		HSS PM	HSS PM	HSSCo 5%	HSSCo 5%	HSS PM	HSS PM
COATING		OX	OX	TIN	TIN	HARD LUBE	HARD LUBE
HELIX ANGLE		B FORM	35°	B FORM	35°	B FORM	35°
		€	€	€	€	€	€
	$L_1 \times L_2 \times D_2 \times \nabla$ mm						
M 3x0,50	2,50 R 56 x 11 x 3,5 x 2,7	20,02	23,79	23,12	26,16	30,58	35,96
M 4x0,70	3,30 R 63 x 13 x 4,5 x 3,4	21,02	23,79	24,25	26,59	32,12	36,90
M 5x0,80	4,20 R 70 x 16 x 6,0 x 4,9	21,02	23,97	24,25	26,99	32,12	37,46
M 6x1,00	5,00 R 80 x 17 x 6,0 x 4,9	23,03	25,92	25,68	28,22	35,17	39,19
M 8x1,00	7,00 D 90 x 20 x 6,0 x 4,9	37,18	40,74				
M 8x1,25	6,80 R 90 x 20 x 8,0 x 6,2	25,69	29,53	29,68	32,51	39,27	45,13
M 10x1,00	9,00 D 90 x 16 x 7,0 x 5,5	38,32	40,91				
M 10x1,50	8,50 R 100 x 22 x 10,0 x 8,0	31,42	35,04	34,70	38,34	47,98	53,52
REDUCED SHANK		M2DX	M4DX	M2DXT	M4DXT	M2DXHL	M4DXHL
M 12x1,00	11,00 D 100 x 22 x 9,0 x 7,0	43,46	49,86				
M 12x1,50	10,50 D 100 x 22 x 9,0 x 7,0	44,11	52,16				
M 12x1,75	10,20 D 110 x 24 x 9,0 x 7,0	40,37	47,27	44,39	49,97	63,18	73,96
M 14x2,00	12,00 D 110 x 26 x 11,0 x 9,0	57,47	65,83	57,83	62,51	83,95	92,96
M 16x2,00	14,00 D 110 x 27 x 12,0 x 9,0	64,00	75,97	65,64	71,93	93,47	112,44
M 18x2,50	15,50 D 125 x 30 x 14,0 x 11,0	95,84	108,10	98,95	102,68	149,99	159,97
M 20x2,50	17,50 D 140 x 32 x 16,0 x 12,0	103,57	114,16	112,98	116,00	159,46	168,91
M 22x2,50	19,50 D 140 x 32 x 18,0 x 14,5	124,28	131,31	140,25	151,85		
M 24x3,00	21,00 D 160 x 34 x 18,0 x 14,5	130,66	149,97	142,98	155,32		
M 27x3,00	24,00 D 160 x 36 x 20,0 x 16,0	171,15	196,45				
M 30x3,50	26,50 D 180 x 40 x 22,0 x 18,0	218,87	251,22				

* Vc: Cutting Speed (m/min)



- **CUT MAGIC XTHICK** Coolant
- We recommend using CUT MAGIC XTHICK to optimize the stainless steel, inconel, titanium.. threading

Ref. ACXT00250

Super Plus TAPS FOR THREADING REFRACTORY ALLOYS

M

DIN 13

TOL
6H

INOX
DUPLEX

Ni

INC

Ti

SPECIALLY RECOMMENDED
 FOR AERONAUTICAL APPLICATIONS

Vc
15 m/min

INOX
DUPLEX

Vc
6 m/min

NICKEL
INCONEL

Vc
6 m/min

TITANIUM

D
REDUCED
SHANK

DIN
376

R
REINFORCED
SHANK

DIN
371

				M2RDU	M4RDU	M2RNI	M3RNI	M2RTIT	M3RTIT
QUALITY				★★★★	★★★★	★★★★	★★★★	★★★★	★★★★
MATERIAL				HSS V3	HSS V3	HSS PM	HSS PM	HSS PM	HSS PM
COATING				TiCN	TiCN	BRIGHT	BRIGHT	OX	OX
HELIX ANGLE				B FORM	41°	B FORM	15°	B FORM	15°
			$L_1 \times L_2 \times D_2 \times \square$ mm	€	€	€	€	€	€
M 3x0,50		2,50	R 56 x 11 x 3,5 x 2,7	41,15	42,15	76,45	78,12	56,76	62,65
M 4x0,70		3,30	R 63 x 13 x 4,5 x 3,4	41,15	42,41	78,12	80,24	58,53	62,65
M 5x0,80		4,20	R 70 x 16 x 6,0 x 4,9	42,53	43,36	80,88	82,79	60,01	66,73
M 6x1,00		5,00	R 80 x 17 x 6,0 x 4,9	43,70	44,63	81,51	83,82	60,01	67,66
M 8x1,25		6,80	R 90 x 20 x 8,0 x 6,2	61,04	63,64	92,12	94,57	69,34	78,12
M 10x1,50		8,50	R 100 x 22 x 10,0 x 8,0	79,11	81,17	109,45	112,80	85,88	94,14
REDUCED SHANK				M2DDU	M4DDU	M2DNI	M3DNI	M2DTIT	M3DTIT
M 12x1,75		10,20	D 110 x 24 x 9,0 x 7,0	106,95	115,49	140,78	155,66	107,78	116,96
M 14x2,00		12,00	D 110 x 26 x 11,0 x 9,0						
M 16x2,00		14,00	D 110 x 27 x 12,0 x 9,0	157,28	168,18				
M 18x2,50		15,50	D 125 x 30 x 14,0 x 11,0						
M 20x2,50		17,50	D 140 x 32 x 16,0 x 12,0	232,89	251,55				
M 22x2,50		19,50	D 140 x 32 x 18,0 x 14,5						
M 24x3,00		21,00	D 160 x 34 x 18,0 x 14,5	315,44	320,85				
M 27x3,00		24,00	D 160 x 36 x 20,0 x 16,0	405,25	424,79				
M 30x3,50		26,50	D 180 x 40 x 22,0 x 18,0	478,61	500,81				

* Vc: Cutting Speed (m/min))

MACHINE TAPS FOR SUPER SOFT CONSTRUCTION STEEL <450 N/mm²

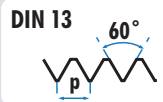

HSSCo
5%

OX

TOL
6H

APPLICATIONS





450
N/mm²

ST52

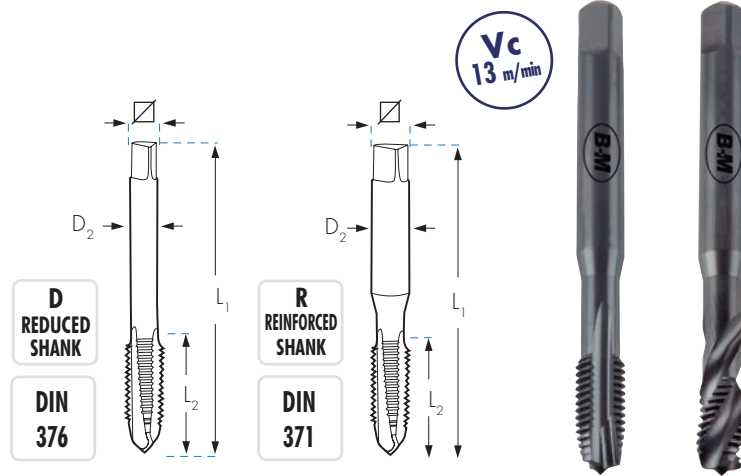
AI



Specific cutting geometry for soft materials without oversize. The tap fits perfectly with this type of materials while the conventional taps can generate oversize when tapping.

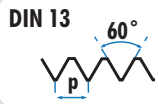
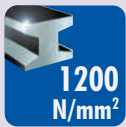
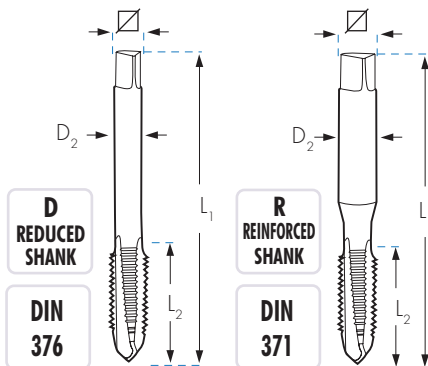

		L ₁ x L ₂ x D ₂ x  mm	M2RSS	M4RSS
			B FORM €	 €
M 3 x 0,50	2,50	R 56 x 11 x 3,5 x 2,7	14,26	19,05
M 4 x 0,70	3,30	R 63 x 13 x 4,5 x 3,4	14,92	19,06
M 5 x 0,80	4,20	R 70 x 16 x 6,0 x 4,9	14,94	18,28
M 6 x 1,00	5,00	R 80 x 17 x 6,0 x 4,9	16,39	20,04
M 8 x 1,25	6,80	R 90 x 20 x 8,0 x 6,2	18,39	22,67
M 10 x 1,50	8,50	R 100 x 22 x 10,0 x 8,0	22,65	26,85
REDUCED SHANK			M2DSS	M4DSS
M 12 x 1,75	10,20	D 110 x 24 x 9,0 x 7,0	28,56	34,58
M 14 x 2,00	12,00	D 110 x 26 x 11,0 x 9,0	42,17	49,80
M 16 x 2,00	14,00	D 110 x 27 x 12,0 x 9,0	49,32	60,16
M 18 x 2,50	15,50	D 125 x 30 x 14,0 x 11,0	70,26	77,99
M 20 x 2,50	17,50	D 140 x 32 x 16,0 x 12,0	75,84	86,46
M 22 x 2,50	19,50	D 140 x 32 x 18,0 x 14,5	91,04	101,46
M 24 x 3,00	21,00	D 160 x 34 x 18,0 x 14,5	108,44	123,32
M 27 x 3,00	24,00	D 160 x 36 x 20,0 x 16,0	135,63	151,73
M 30 x 3,50	26,50	D 180 x 40 x 22,0 x 18,0	174,27	194,45

* Vc: Cutting Speed (m/min)

HSSV3 MACHINE TAPS FOR HARD MATERIALS

**HSS
V3**
**TOL
6H**
**HARD
MATERIALS**

**Vc
7 m/min**
**Vc
9 m/min**

		M2RMD	M4RMD	M2RMDTX	M4RMDTX		
QUALITY		★★★	★★★	★★★★	★★★★		
MATERIAL		HSS V3	HSS V3	HSS V3	HSS V3		
COATING		OX	OX	TINALOX	TINALOX		
HELIX ANGLE		B FORM	35°	B FORM	35°		
							
		$L_1 \times L_2 \times D_2 \times \square$ mm					
		€	€	€	€		
M 3x0,50	2,50	R	56 x 11 x 3,5 x 2,7	17,57	19,24	25,77	30,30
M 4x0,70	3,30	R	63 x 13 x 4,5 x 3,4	17,63	19,30	27,08	31,73
M 5x0,80	4,20	R	70 x 16 x 6,0 x 4,9	17,63	20,25	27,08	31,73
M 6x1,00	5,00	R	80 x 17 x 6,0 x 4,9	20,01	20,92	29,66	33,37
M 8x1,25	6,80	R	90 x 20 x 8,0 x 6,2	21,38	24,69	33,10	38,05
M 10x1,50	8,50	R	100 x 22 x 10,0 x 8,0	24,63	28,43	41,89	46,72
REDUCED SHANK							
M 12x1,75	10,20	D	110 x 24 x 9,0 x 7,0	35,11	40,50	55,79	65,31
M 14x2,00	12,00	D	110 x 26 x 11,0 x 9,0	46,06	48,08	79,38	87,16
M 16x2,00	14,00	D	110 x 27 x 12,0 x 9,0	51,52	58,17	88,42	105,41
M 18x2,50	15,50	D	125 x 30 x 14,0 x 11,0	76,82	82,75	130,00	147,22
M 20x2,50	17,50	D	140 x 32 x 16,0 x 12,0	83,02	87,37	140,50	155,41

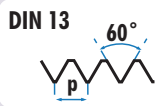
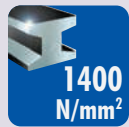
* Vc: Cutting Speed (m/min)

MACHINE TAPS FOR HARDENED MATERIALS (HARDOX 450/500)



**TOL
6H**

HSSE

**HSS
PM**

**SOLID
CARBIDE**

**VERY HARD
MATERIALS**

**48
HRC**

**48-62
HRC**

**Vc
5 m/min**

**SOLID
CARBIDE**

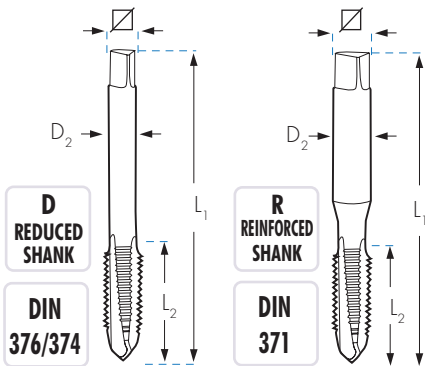

MATERIAL	COATING	FORM	L1 x L2 x D2 x ∇ mm	M2RC	M3RC	M2HRC	M4HRC	M1RCM	M1RHMC
				HSSE	HSSE	HSS PM	HSS PM	HSS PM	SOLID CARBIDE
				TiAIN	TiAIN	TINALOX	TINALOX	TiCN	TiCN
				B FORM	15°	B FORM	35°	C FORM	C FORM
				€	€	€	€	€	€
M 2 x 0,40	1,60	R	40 x 9 x 2,5 x 2,1			34,07	37,25	1,70	
M 3 x 0,50	2,50	R	56 x 11 x 3,5 x 2,7	28,11	29,90	31,09	34,82	2,60	45,03
M 4 x 0,70	3,30	R	63 x 13 x 4,5 x 3,4	28,17	31,85	32,29	36,16	3,40	39,61
M 5 x 0,80	4,20	R	70 x 16 x 6,0 x 4,9	28,44	31,12	32,60	36,51	4,30	44,26
M 6 x 1,00	5,00	R	80 x 17 x 6,0 x 4,9	30,74	34,46	33,99	38,07	5,10	56,67
M 8 x 1,25	6,80	R	90 x 20 x 8,0 x 6,2	35,50	40,51	42,26	47,34	6,90	62,86
M 10 x 1,50	8,50	R	100 x 22 x 10,0 x 8,0	42,50	50,19	50,58	53,11	8,60	81,49
REDUCED SHANK				M2DC	M3DC	M2HDC	M4HDC	M1RCM	M1DHMC
M 12 x 1,75	10,20	D	110 x 24 x 9,0 x 7,0	63,56	75,45	77,21	84,17	10,40	107,81 *
M 14 x 2,00	12,00	D	110 x 26 x 11,0 x 9,0	85,82	100,38	91,56	102,98	12,10	136,30 *
M 16 x 2,00	14,00	D	110 x 27 x 12,0 x 9,0	96,83	115,30	101,80	118,05	14,10	145,80 *
M 18 x 2,50	15,50	D	125 x 30 x 14,0 x 11,0	122,62	133,52	126,02	137,36		15,75
M 20 x 2,50	17,50	D	140 x 32 x 16,0 x 12,0	148,50	154,56	148,82	162,22		17,75
M 22 x 2,50	19,50	D	140 x 32 x 18,0 x 14,5	210,36	219,36				
M 24 x 3,00	21,00	D	160 x 34 x 18,0 x 14,5	215,36	225,36	224,73	244,97		
M 27 x 3,00	24,00	D	160 x 36 x 20,0 x 16,0	235,36	242,36				
M 30 x 3,50	26,50	D	180 x 40 x 22,0 x 18,0	241,25	255,36				

* Vc: Cutting Speed (m/min)

* Reinforced shank: M12 - Ø 12 x 9
M14 - Ø 14 x 11
M16 - Ø 16 x 12



- **CUT MAGIC XTHICK** Coolant
- We recommend using the same machine and exact position as the one used during prior drilling to ensure perfect coaxiality.

Ref. ACXT00250

HRC	Vc (m/min)
48 Hrc	8 m/min
56 Hrc	6 m/min
62 Hrc	3 m/min

ALL ROAD MACHINE TAPS FOR THREADING ANY MATERIAL
**ALL
ROAD**

DIN 13

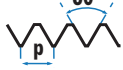

60°

HSSCo
5%

TiN
TOL
6H

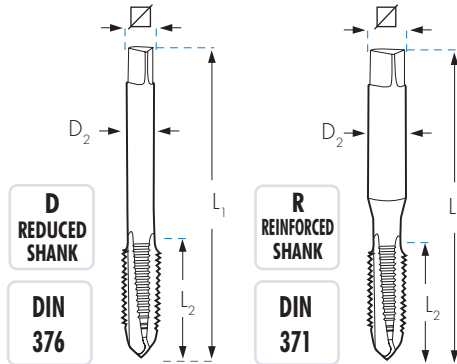
APPLICATIONS
1200
N/mm²
Al
**CAST
IRON**
Ti
INOX
Vc
13 m/min

		$L_1 \times L_2 \times D_2 \times \square$ mm	M2RD	M4RD
			B FORM €	35° €
M 3 x 0,50	2,50	R 56 x 11 x 3,5 x 2,7	26,39	32,99
M 4 x 0,70	3,30	R 63 x 13 x 4,5 x 3,4	28,24	32,99
M 5 x 0,80	4,20	R 70 x 16 x 6,0 x 4,9	30,04	34,17
M 6 x 1,00	5,00	R 80 x 17 x 6,0 x 4,9	31,09	35,47
M 8 x 1,25	6,80	R 90 x 20 x 8,0 x 6,2	36,42	40,47
M 10 x 1,50	8,50	R 100 x 22 x 10,0 x 8,0	42,02	47,94
REDUCED SHANK			M2DD	M4DD
M 12 x 1,75	10,20	D 110 x 24 x 9,0 x 7,0	52,95	63,04
M 14 x 2,00	12,00	D 110 x 26 x 11,0 x 9,0	69,15	75,99
M 16 x 2,00	14,00	D 110 x 27 x 12,0 x 9,0	77,49	83,87
M 18 x 2,50	15,50	D 125 x 30 x 14,0 x 11,0	121,09	124,17
M 20 x 2,50	17,50	D 140 x 32 x 16,0 x 12,0	123,34	127,96

* Vc: Cutting Speed (m/min)

HSSCo & CARBIDE MACHINE TAPS FOR SPECIAL APPLICATIONS

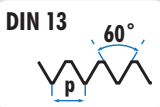
Al
CAST IRON
BRASS

HSSCo 5%
SOLID CARBIDE
TOL 6H



D
REDUCED SHANK
DIN 376



R
REINFORCED SHANK
DIN 371

Vc
18 m/min



Vc
11 m/min



Vc
21 m/min





Vc
16 m/min



Vc
19 m/min





			M5R	M6R	MTRFM	MHMTR	M1RL	M1RLCRN
APPLICATION			Al	Al	CAST IRON	CAST IRON	BRASS	BRASS
MATERIAL			HSSCo 5%	HSSCo 5%	HSSCo 5%	SOLID CARBIDE	HSSCo 5%	HSSCo 5%
COATING			BRIGHT	BRIGHT	OX	BRIGHT	BRIGHT	CrN
FORM			INTERRUPTED THREAD	2 FLUTES	C FORM	C FORM	C FORM	C FORM
		$L_1 \times L_2 \times D_2 \times \square$ mm	€	€	€	€	€	€
M 3x0,50	2,50	R 56 x 11 x 3,5 x 2,7	22,77	24,43	16,11	81,66	19,29	21,91
M 4x0,70	3,30	R 63 x 13 x 4,5 x 3,4	22,90	24,43	16,65	81,66	20,48	24,15
M 5x0,80	4,20	R 70 x 16 x 6,0 x 4,9	22,77	24,95	16,65	81,66	20,48	24,24
M 6x1,00	5,00	R 80 x 17 x 6,0 x 4,9	24,00	26,98	18,91	93,14	22,44	26,47
M 8x1,25	6,80	R 90 x 20 x 8,0 x 6,2	28,73	32,33	21,18	104,00	25,59	32,18
M 10x1,50	8,50	R 100 x 22 x 10,0 x 8,0	34,64	38,23	24,23	130,34	30,78	39,16
REDUCED SHANK			M5D	M6D	M1DFM	MHM1D	M1DL	M1DLCRN
M 12x1,75	10,20	D 110 x 24 x 9,0 x 7,0	44,03	48,05	31,05	181,83	36,59	48,22
M 14x2,00	12,00	D 110 x 26 x 11,0 x 9,0	79,73	82,98	51,04	283,26	44,92	58,76
M 16x2,00	14,00	D 110 x 27 x 12,0 x 9,0	86,90	94,10	60,05	336,99	51,68	65,70
M 18x2,50	15,50	D 125 x 30 x 14,0 x 11,0			84,00	413,09	67,78	83,21
M 20x2,50	17,50	D 140 x 32 x 16,0 x 12,0			84,33	500,23	76,08	92,64

* Vc: Cutting Speed (m/min)



- **CUT MAGIC ALUMINIO** Coolant
- We recommend using CUT MAGIC ALUMINIO to optimize the aluminium and its casts threading

Ref. ACAL00250

FORMING MACHINE TAPS WITH & WITHOUT OIL GROOVES

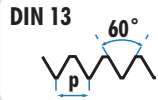

HSSCo
5%

HSSCo
8%

TOL
6HX

APPLICATIONS



Plus

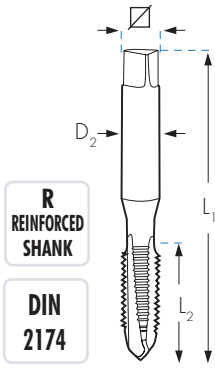

APPLICATION	MATERIAL	COATING	FORM	M07R	M07RT	M07RCR	M07RCCR	M09RCCR	M07RXTCR
	HSSCo 5%	HSSCo 5%	HSSCo 5%	HSSCo 5%	HSSCo 5%	HSSCo 5%	HSSCo 5%	HSSCo 8%	HSSCo 5%
	OX	TiN	OX	TiCN	TiCN	TiCN	TiCN	TiCN	TiN
		$L_1 \times L_2 \times D_2 \times \square$ mm		€	€	€	€	€	€
M 3x0,50	2,75	R	56 x 11 x 3,5 x 2,7	32,21	34,97	35,45	44,48	107,01	79,80
M 3,5x0,60	3,20	R	56 x 11 x 3,5 x 2,7	33,86	38,56	36,62	47,08		
M 4x0,70	3,65	R	63 x 13 x 4,5 x 3,4	32,21	36,47	35,45	46,39	108,36	79,80
M 5x0,80	4,60	R	70 x 16 x 6,0 x 4,9	32,21	36,47	35,45	46,39	109,80	86,12
M 6x1,00	5,50	R	80 x 17 x 6,0 x 4,9	34,78	38,54	38,25	49,03	111,54	86,12
M 8x1,25	7,40	R	90 x 20 x 8,0 x 6,2	40,53	50,87	44,59	64,73	123,73	103,07
M 10x1,50	9,30	R	100 x 22 x 10,0 x 8,0	45,08	57,04	49,60	71,24	147,73	125,83

REDUCED SHANK			M07D	M07DT	M07DCR	M07DCCR	M09DCCR	M07DXTCR
M 12x1,75	11,20	D	110 x 24 x 9,0 x 7,0	53,13	74,59	56,28	81,58	174,88
M 14x2,00	13,05	D	110 x 26 x 11,0 x 9,0	95,78	117,80	99,50	132,44	217,64
M 16x2,00	15,05	D	110 x 27 x 12,0 x 9,0	112,44	132,68	116,79	140,20	299,33
M 18x2,50	16,80	D	125 x 30 x 14,0 x 11,0	129,03	158,65	134,02	165,66	354,67
M 20x2,50	18,80	D	140 x 32 x 16,0 x 12,0	170,01	240,16	176,60	251,84	392,66

MACHINE TAPS WITH SPECIAL TOLERANCE AND OVERSIZE

Threading tools

Pink



		M2R4H	M4R4H	M2R6G	M4R6G	M2R7G	M4R7G	M2R+0,1	M4R+0,1	M2R+0,2	M4R+0,2	
		TOL 4H	TOL 4H	TOL 6G	TOL 6G	TOL 7G	TOL 7G	TOL 6H (+0,1)	TOL 6H (+0,1)	TOL 6H (+0,2)	TOL 6H (+0,2)	
		HSSCo 5%	HSSCo 5%	HSSCo 5%	HSSCo 5%	HSSCo 5%	HSSCo 5%	HSSCo 5%	HSSCo 5%	HSSCo 5%	HSSCo 5%	
		BRIGHT	BRIGHT	BRIGHT	BRIGHT	BRIGHT	BRIGHT	BRIGHT	BRIGHT	BRIGHT	BRIGHT	
		B FORM	35°	B FORM	35°	B FORM	35°	B FORM	35°	B FORM	35°	
		€	€	€	€	€	€	€	€	€	€	
M 3x0,50	2,50 R	56x11x 3,5x 2,7	22,04	27,25	16,17	19,24	22,04	27,25	22,75	30,35	26,10	32,32
M 4x0,70	3,30 R	63x13x 4,5x 3,4	22,55	27,25	16,17	19,24	22,55	27,25	23,29	30,35	26,70	32,32
M 5x0,80	4,20 R	70x16x 6,0x 4,9	22,55	26,11	16,17	18,88	22,55	26,11	23,29	29,07	26,70	30,94
M 6x1,00	5,00 R	80x17x 6,0x 4,9	24,78	28,65	17,41	20,73	24,78	28,65	25,57	31,90	29,35	33,96
M 8x1,00	7,00 D	90x20x 6,0x 4,9			33,90	37,49						
M 8x1,25	6,75 R	90x20x 8,0x 6,2	27,75	32,71	20,24	24,30	27,75	32,71	28,65	36,40	32,88	38,77
M 10x1,00	9,00 D	90x16x 7,0x 5,5			40,04	46,60						
M 10x1,50	8,50 R	100x22x 10,0x 8,0	34,12	38,83	24,90	27,79	34,12	38,83	35,25	43,17	40,46	45,96
REDUCED SHANK		M2D4H	M4D4H	M2D6G	M4D6G	M2D7G	M4D7G	M2D+0,1	M4D+0,1	M2D+0,2	M4D+0,2	
M 12x1,50	10,50 D	100x22x 9,0x 7,0			72,95	86,49						
M 12x1,75	10,20 D	110x24x 9,0x 7,0	44,00	52,24	32,84	39,56	44,00	52,24	44,14	55,96	50,15	59,59
M 14x2,00	12,00 D	110x26x 11,0x 9,0			40,34	48,47			72,01	89,08	81,83	94,87
M 16x2,00	14,00 D	110x27x 12,0x 9,0			49,86	58,54			84,69	107,65	96,27	114,64
M 18x2,50	15,50 D	125x30x 14,0x 11,0			70,31	72,48			128,06	144,99	136,36	154,39
M 20x2,50	17,50 D	140x32x 16,0x 12,0			72,62	83,31			138,37	154,28	147,34	164,29

4H.- Highly accurate threads. Finer adjustment.

6G.- For coating threads. Thicknesses between 20 - 40 μ



7G.- For coating threads. Thicknesses between 40 - 50 μ

6H (+0,1).- To make oversized threads or compensate heat treatment deformations.

6H (+0,2).- To make oversized threads or compensate heat treatment deformations.

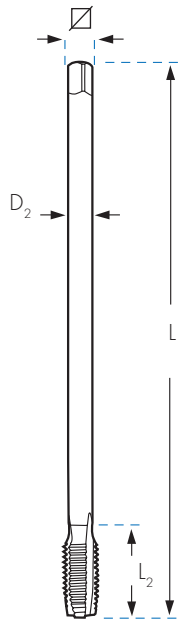



HSSCo EXTRA-LONG MACHINE TAPS
**B
FORM**

**HSSCo
5%**
BRIGHT
**TOL
6H**
**R
REINFORCED
SHANK**
**DIN
371**
**D
REDUCED
SHANK**
**DIN
376**

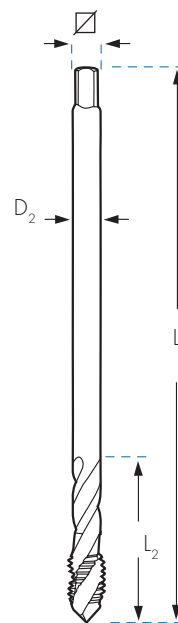
			M2L	
			$L_1 \times L_2 \times D_2 \times \square$ mm	B FORM €
M	3x0,50	2,50	R 100 x 10 x 3,5 x 2,7	36,79
M	4x0,70	3,30	R 120 x 12 x 4,5 x 3,4	37,60
M	5x0,80	4,20	R 140 x 14 x 6,0 x 4,9	37,60
M	6x1,00	5,00	R 160 x 16 x 6,0 x 4,9	41,31
M	7x1,00	6,00	R 160 x 17 x 7,0 x 5,5	46,92
M	8x1,25	6,80	R 180 x 18 x 8,0 x 6,2	48,44

			M2L-D	
			REDUCED SHANK	
M	6x1,00	5,00	D 160 x 16 x 4,5 x 3,4	42,89
M	8x1,25	6,80	D 180 x 18 x 6,2 x 5,0	50,32
M	10x1,50	8,50	D 200 x 20 x 7,0 x 5,5	59,63
M	12x1,75	10,20	D 220 x 22 x 8,5 x 6,5	73,37
M	14x2,00	12,00	D 220 x 25 x 10,5 x 8,0	113,86
M	16x2,00	14,00	D 220 x 28 x 12,5 x 10,0	133,94
M	18x2,50	15,50	D 250 x 32 x 14,0 x 11,0	243,71
M	20x2,50	17,50	D 250 x 32 x 16,0 x 12,0	263,40
M	22x2,50	19,50	D 250 x 35 x 18,0 x 14,5	300,30
M	24x3,00	21,00	D 250 x 38 x 18,0 x 14,5	367,21

**HSSCo
5%**
BRIGHT
**TOL
6H**
**R
REINFORCED
SHANK**
**DIN
371**
**D
REDUCED
SHANK**
**DIN
376**

			M4L	
			$L_1 \times L_2 \times D_2 \times \square$ mm	 €
M	3x0,50	2,50	R 100 x 10 x 3,5 x 2,7	45,52
M	4x0,70	3,30	R 120 x 12 x 4,5 x 3,4	45,52
M	5x0,80	4,20	R 140 x 14 x 6,0 x 4,9	43,61
M	6x1,00	5,00	R 160 x 16 x 6,0 x 4,9	47,84
M	7x1,00	6,00	R 160 x 17 x 7,0 x 5,5	54,31
M	8x1,25	6,80	R 180 x 18 x 8,0 x 6,2	58,13

			M4L-D	
			REDUCED SHANK	
M	6x1,00	5,00	D 160 x 16 x 4,5 x 3,4	49,70
M	8x1,25	6,80	D 180 x 18 x 6,2 x 5,0	59,19
M	10x1,50	8,50	D 200 x 20 x 7,0 x 5,5	67,37
M	12x1,75	10,20	D 220 x 22 x 8,5 x 6,5	87,15
M	14x2,00	12,00	D 220 x 25 x 10,5 x 8,0	127,58
M	16x2,00	14,00	D 220 x 28 x 12,5 x 10,0	184,89
M	18x2,50	15,50	D 250 x 32 x 14,0 x 11,0	275,95
M	20x2,50	17,50	D 250 x 32 x 16,0 x 12,0	293,69
M	22x2,50	19,50	D 250 x 35 x 18,0 x 14,5	328,99
M	24x3,00	21,00	D 250 x 38 x 18,0 x 14,5	375,04

EXTRA-LONG NUT MACHINE TAPS



HSSCo
5%

BRIGHT

TOL
6H

DIN
357

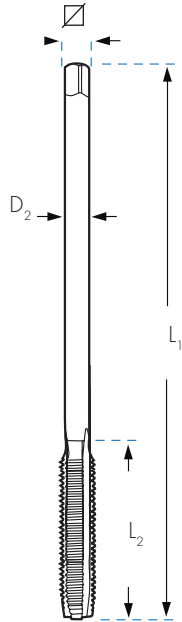

Image	Image	Image	L ₁ x L ₂ x D ₂ x mm	MTU
				A FORM
				€
M 3x0,50**	2,50	D	70 x 22 x 2,2	24,13
M 4x0,70	3,30	D	90 x 25 x 2,8 x 2,1	24,13
M 5x0,80	4,20	D	100 x 28 x 3,5 x 2,7	24,13
M 6x1,00	5,00	D	110 x 32 x 4,5 x 3,4	24,13
M 8x1,25	6,80	D	125 x 40 x 6,0 x 4,9	29,09
M 10x1,50	8,50	D	140 x 45 x 7,0 x 5,5	28,43
M 12x1,75	10,20	D	180 x 50 x 9,0 x 7,0	34,43
M 14x2,00	12,00	D	200 x 56 x 11,0 x 9,0	54,41
M 16x2,00	14,00	D	200 x 63 x 12,0 x 9,0	67,36
M 18x2,50	15,50	D	220 x 63 x 14,0 x 11,0	90,62
M 20x2,50	17,50	D	250 x 70 x 16,0 x 12,0	127,93*
M 22x2,50	19,50	D	280 x 80 x 18,0 x 14,5	156,96*
M 24x3,00	21,00	D	280 x 80 x 18,0 x 14,5	213,57*

**Cylindrical shank

*Available until end of stock

Threading tools

Pink

BLUE-MASTER
by CELESA

CHECK OUR WIDE RANGE OF TOOLS
TO REPAIR ANY KIND OF THREAD P. 659

powercoil
by CELESA

SELF TAPPING
INSERTS

e-zsert
by CELESA

SOLID INSERTS WITH ANAEROBIC
THREADLOCKER

tapsert
by CELESA

SCREW THREAD
INSERTS

loksert
by CELESA

KEY LOCK
INSERTS

HSSCo DRILL-TAPS

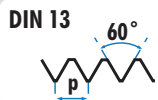
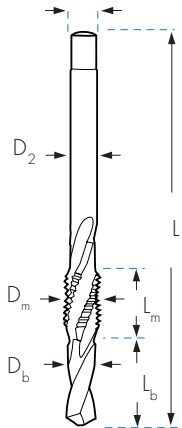

HSSCo
5%
BRIGHT
TOL
6H
R
REINFORCED
SHANK
DIN
371
D
REDUCED
SHANK
DIN
376

								M8M	
		L _b mm	L _m mm	L ₁ mm	D _b mm	D _m mm	D ₂ mm	∅ mm	€
M 3x0,50	R	9,0	12,5	62,0	2,50	3,0	3,5	2,7	36,99
M 4x0,70	R	10,0	16,0	66,0	3,30	4,0	4,5	3,4	36,99
M 5x0,80	R	12,5	18,0	75,5	4,20	5,0	6,0	4,9	38,44
M 6x1,00	R	14,0	20,0	81,0	5,00	6,0	6,0	4,9	42,45
M 8x1,00	R	20,0	14,0	91,0	7,00	8,0	6,0	4,9	49,83
M 8x1,25	R	20,0	14,0	91,0	6,75	8,0	8,0	6,2	47,86
								REDUCED SHANK	
M 8x1,25	D	20,0	14,0	91,0	6,75	8,0	6,0	4,9	51,70
M 10x1,00	D	20,0	15,0	95,0	9,00	10,0	7,0	5,5	61,85
M 10x1,50	D	25,0	18,0	105,0	8,50	10,0	7,0	5,5	65,65
M 12x1,50	D	24,0	18,0	110,0	10,50	12,0	9,0	7,0	71,65
M 12x1,75	D	28,0	20,0	118,0	10,20	12,0	9,0	7,0	71,23
M 14x1,50	D	28,0	20,0	118,0	12,50	14,0	11,0	9,0	113,38
M 14x2,00	D	28,0	22,0	130,0	12,00	14,0	11,0	9,0	128,96
M 16x2,00	D	36,0	24,0	139,0	14,00	16,0	12,0	9,0	169,61
M 18x2,50	D	40,0	26,0	151,0	15,50	18,0	14,0	11,0	247,38
M 20x2,50	D	45,0	30,0	168,0	17,50	20,0	16,0	12,0	355,26

Note: Never use the drill taps in blind hole or through hole deeper than L_b

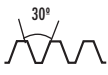
HSS MACHINE TAPS FOR TRAPEZOIDAL THREADS

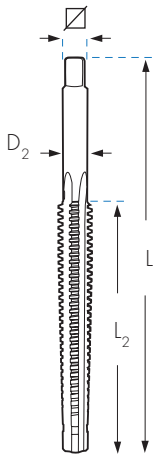
HSS
BRIGHT

DIN
103
TOL
7H

			MRTM
		L ₁ x L ₂ x D ₂ x ∅ mm	€
Tr 14 x 3	11,25	160 x 105 x 10,5 x 8,0	570,43
Tr 16 x 4	12,25	205 x 110 x 11,5 x 9,0	593,84
Tr 18 x 4	14,25	215 x 120 x 13,0 x 10,0	626,00
Tr 20 x 4	16,25	230 x 130 x 15,0 x 12,0	628,93
Tr 22 x 5	17,25	270 x 165 x 16,0 x 12,0	827,86
Tr 24 x 5	19,25	280 x 165 x 18,0 x 14,5	939,03
Tr 26 x 5	21,25	290 x 170 x 20,0 x 16,0	971,60
Tr 28 x 5	23,25	300 x 180 x 22,0 x 18,0	1.100,61
Tr 30 x 6	24,25	345 x 200 x 23,0 x 18,0	1.266,65

INDEXABLE THREAD TURNING INSERT

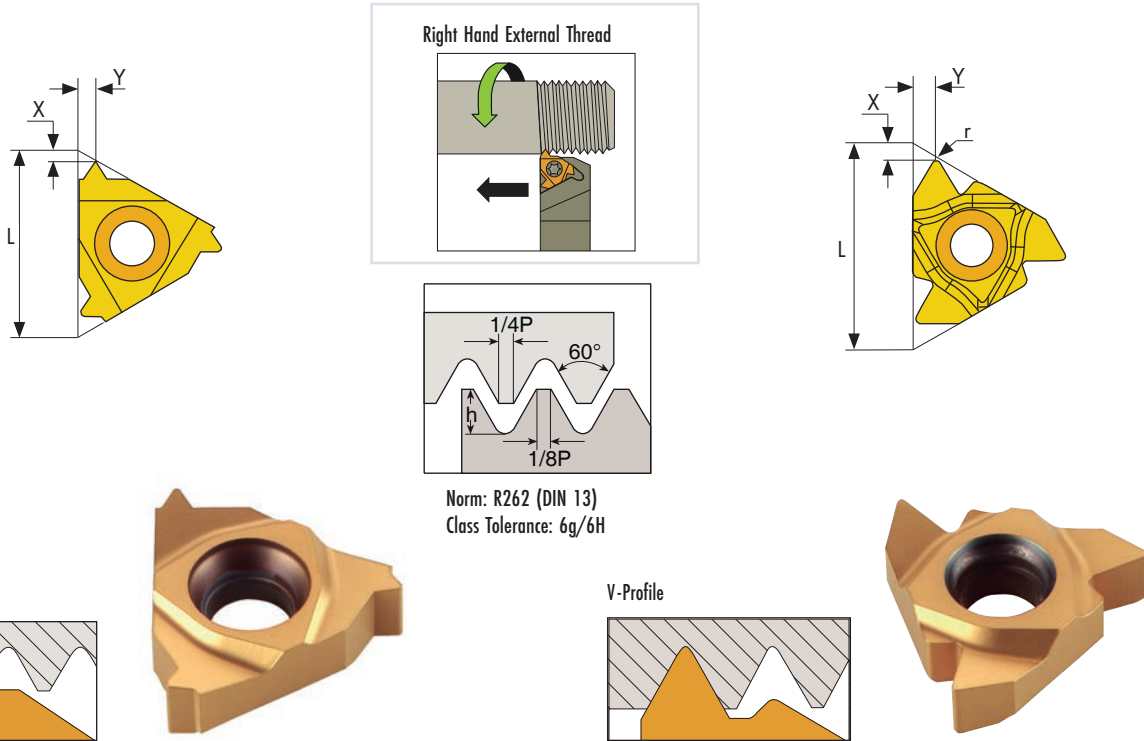

Norm: R262 (DIN 13)
Class Tolerance: 6g/6H

Full Profile

V-Profile

Form a complete thread, including the crest.
We'll need a separate insert for each pitch and profile

Doesn't top the thread crests.
The same insert may be used for a range of pitches with the same thread profile angle

FULL PROFILE 60°

EXTERNAL THREADING	L	PITCH	h	X	Y	€
PRE-16-075	16	0,75	0,46	0,6	0,6	25,56*
PRE-16-100		1,00	0,61	0,7	0,7	25,56*
PRE-16-125		1,25	0,77	0,8	0,9	25,56*
PRE-16-150		1,50	0,92	0,8	1	25,56*
PRE-16-175		1,75	1,07	0,9	1,2	25,56*
PRE-16-200		2,00	1,23	1	1,3	25,56*
PRE-16-250		2,50	1,53	1,1	1,5	25,56*
PRE-16-300		3,00	1,84	1,2	1,6	25,56*

* Till end of stock

V-PROFILE 60°

EXTERNAL THREADING	L	METRIC RANGE	INCH RANGE	r	X	Y	€
PPRE-16-150	16	0,50-1,50	48 - 16	0,05	0,80	0,90	25,56*
PPRE-16-300		1,75-3,00	14 - 8	0,27	1,20	1,70	25,56*

* Till end of stock

TOOL HOLDER FOR EXTERNAL THREADING

EXTERNAL THREADING	H1=H=B=F	L1	L2	€
PEXT-25-16	25	153	30	186,87*

* Till end of stock

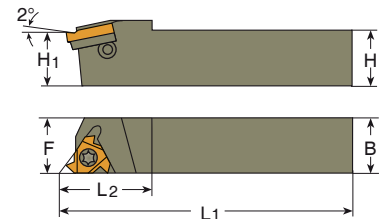

	Cs		Cs
STEEL 70 kg/mm ²	25 m / min	ALUMINIUM	50 m / min
HARDENED STEEL 120 kg/mm ²	13 m / min	TITANIUM	18 m / min
STAINLESS STEEL	11 m / min	CAST IRON	25 m / min
		BRASS	50 m / min

FORMULA TO CALCULATE THE TURNING SPEED OF THE WORKPIECE

N: Revolution per Minute
Vc: Cutting Speed (m/min)
D: Workpiece Diameter (mm)

$$RPM = \frac{1000 \times Vc}{\pi \times D}$$

RPM Depends on Vc and D

INDEXABLE THREAD TURNING INSERT

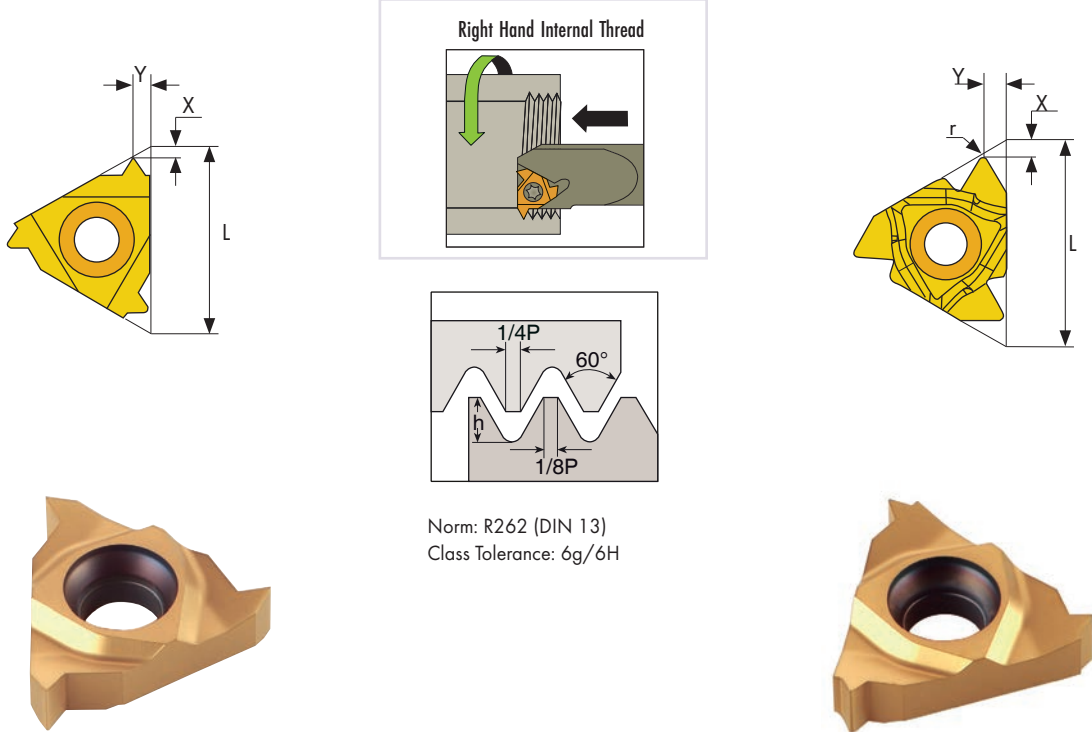

Norm: R262 (DIN 13)
Class Tolerance: 6g/6H

FULL PROFILE 60°

INTERNAL THREADING	L	PITCH	h	X	Y	€
PRI-16-075	16	0,75	0,43	0,6	0,6	25,56*
PRI-16-100		1,00	0,58	0,6	0,7	25,56*
PRI-16-125		1,25	0,72	0,8	0,9	25,56*
PRI-16-150		1,50	0,87	0,8	1,0	25,56*
PRI-16-175		1,75	1,01	0,9	1,2	25,56*
PRI-16-200		2,00	1,15	1,0	1,3	25,56*
PRI-16-250		2,50	1,44	1,1	1,5	25,56*
PRI-16-300		3,00	1,73	1,1	1,5	25,56*

* Till end of stock

V-PROFILE 60°

INTERNAL THREADING	L	METRIC RANGE	INCH RANGE	r	X	Y	€
PPRI-16-150	16	0,50-1,50	48 - 16	0,05	0,80	0,90	25,56*
PPRI-16-300		1,75-3,00	14 - 8	0,16	1,20	1,70	25,56*

* Till end of stock

TOOL HOLDER FOR INTERNAL THREADING

INTERNAL THREADING	L	L1	D	D1	A	∅ Min. Hole	€
PINT-20-16	180	40	20	20	18	24	184,18*
PINT-25-16	200	45	25	24,6	22,6	29	225,20*

* Till end of stock

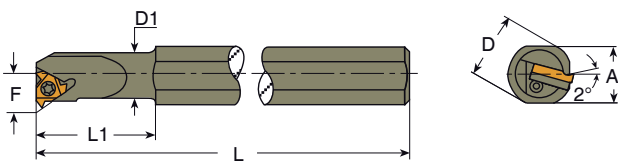

MACHINE TAPS FOR GENERAL PURPOSE IN METAL BOXES

**GENERAL
PURPOSE**

**HSSCo
5%**



Ref. JM6



Ref. JM2





Ref. JM8



Ref. JM4

CONTENT

	C FORM	B FORM	 15°	 35°	 HSS	HSSCo 5% €
JM5	M3 - M4 - M5 - M6 M8 - M10 - M12	-	-	-	-	106,49
JM1	M3 - M4 - M5 - M6 M8 - M10 - M12	-	-	-	2.5 / 3.3 / 4.2 / 5.0 6.8 / 8.5 / 10.2 mm	127,37
JM6	-	M3 - M4 - M5 - M6 M8 - M10 - M12	-	-	-	113,46
JM2	-	M3 - M4 - M5 - M6 M8 - M10 - M12	-	-	2.5 / 3.3 / 4.2 / 5.0 6.8 / 8.5 / 10.2 mm	127,60
JM7	-	-	M3 - M4 - M5 - M6 M8 - M10 - M12	-	-	141,35
JM3	-	-	M3 - M4 - M5 - M6 M8 - M10 - M12	-	2.5 / 3.3 / 4.2 / 5.0 6.8 / 8.5 / 10.2 mm	168,90
JM8	-	-	-	M3 - M4 - M5 - M6 M8 - M10 - M12	-	143,79
JM4	-	-	-	M3 - M4 - M5 - M6 M8 - M10 - M12	2.5 / 3.3 / 4.2 / 5.0 6.8 / 8.5 / 10.2 mm	167,10

MACHINE TAPS FOR SPECIAL APPLICATIONS IN METAL BOXES
Plus

Ref. JMPT2

CONTENT

	B FORM	BRIGHT	35° BRIGHT	HSSCo 5%	HSS PM €		TiN €
JMP6	M3 - M4 - M5 - M6 M8 - M10 - M12		-	-	118,23	JMPT6	170,52
JMP2	M3 - M4 - M5 - M6 M8 - M10 - M12		-	2.5 / 3.3 / 4.2 / 5.0 6.8 / 8.5 / 10.2 mm	155,05	JMPT2	207,48
JMP8	-		M3 - M4 - M5 - M6 M8 - M10 - M12	-	170,52	JMPT8	187,81
JMP4	-		M3 - M4 - M5 - M6 M8 - M10 - M12	2.5 / 3.3 / 4.2 / 5.0 6.8 / 8.5 / 10.2 mm	207,48	JMPT4	224,89

INOX
CONTENT

	B FORM	OX	35° OX	HSSCo 5%	HSS PM €		TiN €
JMX6	M3 - M4 - M5 - M6 M8 - M10 - M12		-	-	152,53	JMXT6	166,39
JMX2	M3 - M4 - M5 - M6 M8 - M10 - M12		-	2.5 / 3.3 / 4.2 / 5.0 6.8 / 8.5 / 10.2 mm	189,50	JMXT2	203,36
JMX8	-		M3 - M4 - M5 - M6 M8 - M10 - M12	-	174,07	JMXT8	191,90
JMX4	-		M3 - M4 - M5 - M6 M8 - M10 - M12	2.5 / 3.3 / 4.2 / 5.0 6.8 / 8.5 / 10.2 mm	211,02	JMXT4	228,85

**1200
N/mm²**
CONTENT

	B FORM	OX	35° OX	HSSCo 5%	HSS V3 €		TINALOX €
JMMD6	M3 - M4 - M5 - M6 M8 - M10 - M12		-	-	138,65	JMMDT6	196,84
JMMD2	M3 - M4 - M5 - M6 M8 - M10 - M12		-	2.5 / 3.3 / 4.2 / 5.0 6.8 / 8.5 / 10.2 mm	175,61	JMMDT2	233,79
JMMD8	-		M3 - M4 - M5 - M6 M8 - M10 - M12	-	158,24	JMMDT8	226,98
JMMD4	-		M3 - M4 - M5 - M6 M8 - M10 - M12	2.5 / 3.3 / 4.2 / 5.0 6.8 / 8.5 / 10.2 mm	195,19	JMMDT4	263,93

MACHINE TAPS FOR SPECIAL APPLICATIONS IN METAL BOXES

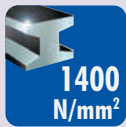

Ref. JMC2

CONTENT

	B FORM	TiCN	15°	TiCN	HSSCo 5%	HSS-PM €
JMC6	M3 - M4 - M5 - M6 M8 - M10 - M12		-		-	235,86
JMC2	M3 - M4 - M5 - M6 M8 - M10 - M12		-		2.5 / 3.3 / 4.2 / 5.0 6.8 / 8.5 / 10.2 mm	272,82
JMC8	-		M3 - M4 - M5 - M6 M8 - M10 - M12		-	268,47
JMC4	-		M3 - M4 - M5 - M6 M8 - M10 - M12		2.5 / 3.3 / 4.2 / 5.0 6.8 / 8.5 / 10.2 mm	305,43

ALL ROAD

CONTENT

	B FORM	TiN	35°	TiN	HSSCo 5%	HSSCo 5% €
JMD6	M3 - M4 - M5 - M6 M8 - M10 - M12		-		-	213,14
JMD2	M3 - M4 - M5 - M6 M8 - M10 - M12		-		2.5 / 3.3 / 4.2 / 5.0 6.8 / 8.5 / 10.2 mm	250,10
JMD8	-		M3 - M4 - M5 - M6 M8 - M10 - M12		-	240,36
JMD4	-		M3 - M4 - M5 - M6 M8 - M10 - M12		2.5 / 3.3 / 4.2 / 5.0 6.8 / 8.5 / 10.2 mm	277,32

AI

CONTENT

	INTERRUPTED THREAD	BRIGHT	2 FLUTES	BRIGHT	HSS	HSSCo 5% €
JMAL6	M3 - M4 - M5 - M6 M8 - M10 - M12		-		-	168,76
JMAL2	M3 - M4 - M5 - M6 M8 - M10 - M12		-		2.5 / 3.3 / 4.2 / 5.0 6.8 / 8.5 / 10.2 mm	205,71
JMAL8	-		M3 - M4 - M5 - M6 M8 - M10 - M12		-	166,88
JMAL4	-		M3 - M4 - M5 - M6 M8 - M10 - M12		2.5 / 3.3 / 4.2 / 5.0 6.8 / 8.5 / 10.2 mm	203,84

MACHINE TAPS IN PLASTIC BOXES
**GENERAL
PURPOSE**
CONTENT

	B FORM	BRIGHT	 35°	BRIGHT	HSSCo 5%	€
PT01	M4 - M5 - M6 M8 - M10		M4 - M5 - M6 M8 - M10			129,44



Ref. PT01

Plus
CONTENT

	B FORM	BRIGHT	 35°	BRIGHT	HSS PM		TiN
					€		€
PT02	M4 - M5 - M6 M8 - M10		M4 - M5 - M6 M8 - M10		162,83	PT03	239,13



Ref. PT03

INOX
CONTENT

	B FORM	OX	 35°	OX	HSS PM		TiN
					€		€
PT05	M4 - M5 - M6 M8 - M10		M4 - M5 - M6 M8 - M10		213,95	PT13	227,69

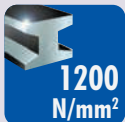

Ref. PT05

CONTENT

	B FORM	OX	 35°	OX	HSS V3		TINALOX
					€		€
PT04	M4 - M5 - M6 M8 - M10		M4 - M5 - M6 M8 - M10		183,61	PT14	275,93

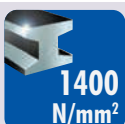

Ref. PT04

CONTENT

	B FORM	TiCN	 15°	TiCN	HSS PM	€
PT11	M4 - M5 - M6 M8 - M10		M4 - M5 - M6 M8 - M10			332,64



Ref. PT11

MACHINE TAPS IN PLASTIC BOXES

Al



Ref. PT06

CONTENT

	INTERRUPTED THREAD	2 FLUTES	HSSCo 5% €
PT06	M4 - M5 - M6 M8 - M10	M4 - M5 - M6 M8 - M10	202,99

**CAST
IRON**



Ref. PT07

CONTENT

	C FORM	HSSCo 5% €
PT07	M4 - M5 - M6 - M8 - M10 M4 - M5 - M6 - M8 - M10	153,41

BRASS



Ref. PT10

CONTENT

	C FORM	HSSCo 5% €
PT10	M4 - M5 - M6 - M8 - M10 M4 - M5 - M6 - M8 - M10	186,49



FORMING



Ref. PT08

CONTENT

		HSSCo 5% €
PT08	M4 - M5 - M6 - M8 - M10 M4 - M5 - M6 - M8 - M10	280,77



Ref. PT09

CONTENT

		HSSCo 5% €
PT09	M4 - M5 - M6 - M8 - M10 M4 - M5 - M6 - M8 - M10	378,25

**TOL
6G**



Ref. PT12

CONTENT

	B FORM	 35°	HSSCo 5% €
PT12	M4 - M5 - M6 M8 - M10	M4 - M5 - M6 M8 - M10	209,75

MACHINE TAPS METHACRYLATE DISPLAYS
METHACRYLATE DISPLAY

MM-03

Content: Standard series machine taps

HSSCo
5%

Ref. MM-03

B
FORM

B Form through holes: Ref. M2

<u>M4</u>	<u>M5</u>	<u>M6</u>	<u>M8</u>	<u>M10</u>	<u>M12</u>	<u>M14</u>
5	10	10	10	10	5	4



35°

35° blind holes: Ref. M4

<u>M4</u>	<u>M5</u>	<u>M6</u>	<u>M8</u>	<u>M10</u>	<u>M12</u>	<u>M14</u>
5	10	10	10	10	5	4

Dimensions: width 240 x depth 240 x height 245 mm.

1.992,33 €



Ref. MM-04

METHACRYLATE DISPLAY

MM-04

 Content: Plus series machine taps
 Manufactured in powder steel (ASP)

HSS
PM
Plus
B
FORM

B Form through holes: Ref. M2

<u>M4</u>	<u>M5</u>	<u>M6</u>	<u>M8</u>	<u>M10</u>	<u>M12</u>	<u>M14</u>
5	10	10	10	10	5	4



35°

35° blind holes: Ref. M4

<u>M4</u>	<u>M5</u>	<u>M6</u>	<u>M8</u>	<u>M10</u>	<u>M12</u>	<u>M14</u>
5	10	10	10	10	5	4

Dimensions: width 240 x depth 240 x height 245 mm.

2.718,13 €

METHACRYLATE DISPLAY

MM-05

Content: Machine taps for special works

B
FORM

B Form through holes: Ref. M2

1200
N/mm²

<u>M4</u>	<u>M5</u>	<u>M6</u>	<u>M8</u>	<u>M10</u>	<u>M12</u>	<u>M14</u>
1	2	2	2	2	1	1



INOX

<u>M4</u>	<u>M5</u>	<u>M6</u>	<u>M8</u>	<u>M10</u>	<u>M12</u>	<u>M14</u>
1	2	2	2	2	1	1



AI

<u>M4</u>	<u>M5</u>	<u>M6</u>	<u>M8</u>	<u>M10</u>	<u>M12</u>	<u>M14</u>
1	2	2	2	2	1	1



TiN

<u>M4</u>	<u>M5</u>	<u>M6</u>	<u>M8</u>	<u>M10</u>	<u>M12</u>	<u>M14</u>
1	2	2	2	2	1	1

1400
N/mm²

<u>M4</u>	<u>M5</u>	<u>M6</u>	<u>M8</u>	<u>M10</u>	<u>M12</u>
1	2	2	2	2	1



35°

35° blind holes: Ref. M4

1200
N/mm²

<u>M4</u>	<u>M5</u>	<u>M6</u>	<u>M8</u>	<u>M10</u>	<u>M12</u>	<u>M14</u>
1	2	2	2	2	1	1



INOX

<u>M4</u>	<u>M5</u>	<u>M6</u>	<u>M8</u>	<u>M10</u>	<u>M12</u>	<u>M14</u>
1	2	2	2	2	1	1



AI

<u>M4</u>	<u>M5</u>	<u>M6</u>	<u>M8</u>	<u>M10</u>	<u>M12</u>	<u>M14</u>
1	2	2	2	2	1	1



TiN

<u>M4</u>	<u>M5</u>	<u>M6</u>	<u>M8</u>	<u>M10</u>	<u>M12</u>	<u>M14</u>
1	2	2	2	2	1	1

1400
N/mm²

<u>M4</u>	<u>M5</u>	<u>M6</u>	<u>M8</u>	<u>M10</u>	<u>M12</u>
1	2	2	2	2	1

Dimensions: width 240 x depth 240 x height 245 mm.

3.395,23 €