

BLUE-MASTER®
by *celesa*







FRESAS

FRESAS FRONTAIS SÉRIE CURTA DE 2 NAVALHAS DIN 327 E DIN 844

FRESAS

Rosa

2Z     **INOX** **Al** **TOL D2 h6** Ref. FFAL 



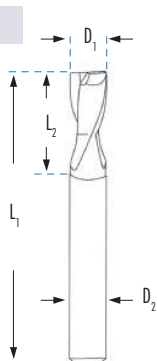

SÉRIE CURTA



DIN 327	MATERIAL ACABAMENTO QUALIDADE				FF01	FF02	FF60	FT02	FF92	FP05	FT12	FP08	FT01	DIN 844
	D1 mm	L1 mm	L2 mm	D2 mm	HSS BRILHANTE ★ TOL e8 €	HSSCo 8% BRILHANTE ★★ TOL e8 €	HSSCo 8% TiAIN ★★★ TOL e8 €	HSSCo 8% TiAISIN ★★★★ TOL e8 €	HSSCo 8% BRILHANTE ★★ TOL h10 €	ASP 60 BRILHANTE Premium Quality TOL e8 €	ASP 60 TiAISIN Premium Quality TOL e8 €	ASP 60 BRILHANTE Premium Quality TOL h10 €	ASP 60 TiAISIN Premium Quality TOL h10 €	
1,00	47	2,5	6							24,80	32,13	36,16	43,16	
2,00	48	4,0	6	11,27	14,28	23,42	27,31	29,07	20,92	28,56	31,92	39,24	17,27	
2,50	49	5,0	6		14,28	23,42	27,31	30,92					17,62	
3,00	49	5,0	6	11,27	14,28	23,42	27,31	29,21	20,92	28,56	31,92	39,24	17,23	
3,50	50	6,0	6		15,51	24,63	28,69	30,92					18,28	
4,00	51	7,0	6	11,06	14,28	23,43	27,32	29,21	19,02	27,30	31,92	39,24	17,74	
4,50	52	8,0	6	11,06*	17,06	25,99	30,31	30,92					19,42	
5,00	52	8,0	6	11,06	14,28	23,43	27,32	29,21	19,02	27,30	31,92	39,24	17,74	
5,50	52	8,0	6		17,65	26,67	31,09	30,92					21,73	
6,00	52	8,0	6	11,06	14,28	23,43	27,32	29,21	19,02	27,30	31,92	39,24	19,23	
6,50	60	10,0	10	16,49*	23,10	33,42	38,96						28,42	
7,00	60	10,0	10	16,49	22,41	32,71	38,14	35,20	28,70	37,75	42,23	55,85	25,84	
7,50	61	11,0	10		22,20	32,49	37,89						30,30	
8,00	61	11,0	10	13,42	18,46	28,89	33,71	31,35	24,93	37,01	42,23	55,85	23,39	
8,50	61	11,0	10		24,94	36,14	42,14						31,94	
9,00	61	11,0	10	17,15	22,80	34,16	39,82	36,04	30,69	40,77	42,23	57,53	28,95	
9,50	63	13,0	10		24,40	35,36	41,22							
10,00	63	13,0	10	14,11	18,34	29,75	34,87	31,10	27,77	37,72	42,23	57,53	25,28	
10,50	70	13,0	12		29,31	44,51	51,18							
11,00	70	13,0	12		27,83	40,73	47,50	43,92					34,91	
12,00	73	16,0	12	18,44	24,56	37,29	43,48	41,45	35,43	48,68	57,51	73,11	31,71	
13,00	73	16,0	12		35,82	50,22	58,56	54,77					45,19	
14,00	73	16,0	12	26,23	35,82	50,22	58,56	54,77	43,19	59,70	64,99	80,90	44,36	
15,00	73	16,0	12		40,05	56,89	66,35	58,91					48,72	
16,00	79	19,0	16	27,38	35,45	52,21	60,89	59,84	54,07	70,76	75,99	94,40	47,47	
17,00	79	19,0	16		48,12	66,66	77,74						66,05	
18,00	79	19,0	16	35,87	48,12	66,73	77,82	72,88	68,47	84,40	96,32	145,50	59,29	
19,00	79	19,0	16		60,13	80,81	94,26						79,97	
20,00	88	22,0	16		62,94	85,99	100,27							
20,00	88	22,0	20	42,05	56,92	77,76	90,69	87,04	80,65	101,51	112,29	148,61	68,54	
22,00	88	22,0	20	57,68	75,18	103,05	120,16	113,90	102,72	142,39	133,35	170,66	95,41	
24,00	102	26,0	25	72,38	97,02	127,96	149,20	136,12					143,38	
25,00	102	26,0	25	72,40	94,52	122,70	143,08	125,08	137,13	171,56	174,80*	215,98*	121,44	
26,00	102	26,0	25		110,87	169,89	195,34						190,72	
28,00	102	26,0	25	90,70	119,35	159,21	186,56						147,77	
30,00	102	26,0	25	104,35	135,99	176,25	205,52	181,17					170,05	
32,00	112	32,0	32	108,21	139,69	179,48	209,30						180,11	
36,00	112	32,0	32	139,32	186,85	230,56	268,86							
40,00	130	38,0	32	169,38	229,44	285,06	332,43							

*Hasta fin de existencia

FRESAS FRONTAIS SÉRIE LONGA DE 2 NAVALHAS DIN 327 E DIN 844/L

2 Z



INOX
Al
TOL D2 h6
Ref. FFLAL 

SÉRIE LONGA



DIN 327/L				MATERIAL ACABAMENTO QUALIDADE					DIN 844/L				
				FF06	FF67	FT06	FF15	FP21					FFLAL
D1 mm	L1 mm	L2 mm	D2 mm	HSSCo 8% BRILHANTE ★★ TOL e8 €	HSSCo 8% TiAlN ★★★ TOL e8 €	HSSCo 8% TiAlSiN ★★★★ TOL e8 €	HSSCo 8% BRILHANTE ★★ TOL h10 €	ASP 60 BRILHANTE Premium Quality TOL h10 €	HSSCo 8% BRILHANTE Al TOL e8 €	L1 mm	L2 mm	D2 mm	€
2,00	54	7	6	15,74*	24,82*	28,94*	31,96	37,49*		54	10	6	26,03
2,50	56	8	6	15,82*	24,82*	28,94*	32,00			56	12	6	
3,00	56	8	6	15,74	24,89	29,03	32,00	38,64*		56	12	6	26,16
3,50	59	10	6	17,88	29,56	34,50				59	15	6	
4,00	63	11	6	15,81	24,89	29,03	32,00	38,64		63	19	6	26,32
4,50	63	11	6	17,88	25,42	29,64				63	19	6	
5,00	68	13	6	15,81	24,89	29,03	33,88	40,90*		68	24	6	26,45
5,50	68	13	6	17,88	29,56	34,50				68	24	6	
6,00	68	13	6	15,81	24,89	29,03	30,62	36,95*		68	24	6	27,46
6,50	80	16	10	29,65	48,52	55,79				68	24	6	
7,00	80	16	10	26,10	36,44	42,50	38,62	46,18*		80	30	10	
7,50	88	19	10							80	30	10	
8,00	88	19	10	22,97	33,27	38,82	38,62	46,60*		88	38	10	37,52
8,50	88	19	10	35,16	47,85	55,80				88	38	10	
9,00	88	19	10	30,91	42,14	49,12	42,36			88	38	10	39,57
10,00	95	22	10	25,31	38,54	44,94	42,18	51,16*		95	45	10	37,52
11,00	102	22	12	39,90	53,83	62,76	56,18			102	45	12	52,58*
12,00	110	26	12	36,39	50,90	59,36	55,10	66,21*		110	53	12	48,54
13,00	110	26	12							110	53	12	
14,00	110	26	12	47,96	62,21	72,54	73,10	82,98		110	53	12	55,56
15,00	123	32	16							110	53	12	
16,00	123	32	16	54,97	76,77	89,54	83,20	99,03		123	63	16	67,82
17,00	123	32	16							123	63	16	
18,00	123	32	16	62,81	90,12	105,06	99,99	118,99		123	63	16	83,93
20,00	141	38	20	72,23	98,85	115,28	108,42	129,01		141	75	20	100,11
22,00	141	38	20	99,03	134,14	156,42	134,39	159,94		141	75	20	
24,00	166	45	25	150,70	170,66	196,22	180,78			166	90	25	
25,00	166	45	25	142,06	180,50	210,49	165,29	196,70		166	90	25	
26,00	166	45	25	188,64	200,96	231,06				166	90	25	
28,00	166	45	25	172,15	219,75	256,27				166	90	25	
30,00	166	45	25	191,37	236,56	275,85	246,22			166	90	25	
32,00	186	53	32	264,76	308,38	359,59	320,82			186	106	32	
36,00	186	53	32	299,54	350,63	408,87				186	106	32	
40,00	196	63	32	392,53	473,72	552,43				196	125	32	

FRESAS FRONTAIS SÉRIE CURTA DE 3 NAVALHAS DIN 844 E DIN 327

3Z

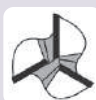

INOX

Al

TOL D₂
h₆

SÉRIE CURTA

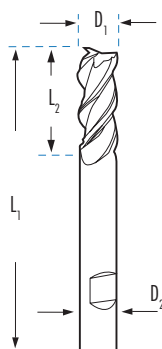

DIN 844				MATERIAL	FF63	FF75	FT63	FF73	FF76	FT73	FP06	FT03
ACABAMENTO				HSSCo 8%	HSSCo 8%	HSSCo 8%	HSSCo 8%	HSSCo 8%	HSSCo 8%	HSSCo 8%	ASP 60	ASP 60
QUALIDADE				BRILHANTE	TiAIN	TiAlSiN	BRILHANTE	TiAIN	TiAlSiN	TiAlSiN	BRILHANTE	TiAlSiN
DESBASTE				★★	★★★	★★★★	★★	★★★	★★★★	★★★★	Premium Quality	Premium Quality
TOL k10				TOL k10	TOL k10	TOL k10	TOL k12	TOL k12	TOL k12	TOL k12	TOL e8	TOL e8
D ₁ mm	L ₁ mm	L ₂ mm	D ₂ mm	€	€	€	€	€	€	€	€	€
1,00	49	3	6								26,66	33,20
2,00	51	7	6	15,69	24,70	28,80					21,66	32,43
2,50	52	8	6	15,69	24,70	28,80						
3,00	52	8	6	15,65	24,70	28,80					21,66	32,43
3,50	55	11	6	16,17	25,16	29,49						
4,00	55	11	6	15,68	24,70	28,80					21,66	32,43
4,50	57	13	6	17,27	26,10	30,44						
5,00	57	13	6	15,68	24,81	28,94					21,66	32,43
5,50	57	13	6	21,32	33,96	39,59						
6,00	57	13	6	16,52	27,75	32,35	44,77	54,08	62,16	21,66	32,43	
6,50	66	16	10	29,62	45,42	52,23						
7,00	66	16	10	23,08	33,35	39,05	52,96*	64,55	74,22	29,16	39,52	
7,50	69	19	10	29,84*	45,90*	52,78*						
8,00	69	19	10	20,61	30,78	35,91	45,88	53,45	62,34	29,16	39,52	
8,50	69	19	10	31,45	47,40	54,50						
9,00	69	19	10	25,74	36,92	43,05	54,45*	63,92*				
9,50	72	22	10		49,81*	57,26*						
10,00	72	22	10	22,33	33,42	38,96	46,17	56,82	66,24	30,91	40,88	
11,00	79	22	12	35,46	52,74	60,64	66,62*	76,75*				
12,00	83	26	12	28,04	39,88	46,51	55,55	65,38	76,25	39,87	51,70	
13,00	83	26	12	44,60	61,32	70,51		84,52*				
14,00	83	26	12	38,20	52,31	61,01	63,39	74,58	86,98	51,66	62,96	
15,00	83	26	12	45,82	63,64	73,18	80,23	87,82	96,80			
16,00	92	32	16	41,94	58,38	68,08	76,84	92,66	108,09	60,76	72,48	
17,00	92	32	16	68,64	90,13	103,62						
18,00	92	32	16	52,70	71,28	83,13	84,07	102,01	118,97	74,77	88,65	
19,00	92	31	16	83,94	103,69	119,24						
20,00	104	38	20	60,51	80,34	93,70	102,58	120,00	139,93	88,92	106,13	
22,00	104	38	20	96,46	121,31	139,48				118,70*	151,83*	
25,00	121	45	25	126,03	160,61	184,68	155,38	177,56	207,06	149,01*	171,22*	
28,00	121	45	25	146,40	179,60	206,49						
30,00	121	45	25	180,10	210,93	242,53	193,22	227,98	265,87			
32,00	133	53	32	183,31	227,65	261,75						

FRESAS FRONTAIS SÉRIE LONGA DE 3 NAVALHAS DIN 844/L

3 Z



SÉRIE LONGA

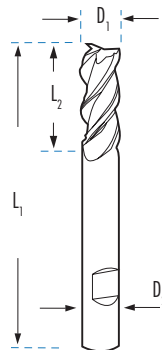

DIN 844/L		MATERIAL		FF83	FF86	FT83
		ACABAMENTO		HSSCo 8%	HSSCo 8%	HSSCo 8%
		QUALIDADE		BRILHANTE	TiAlN	TiAlSiN
				★★	★★★	★★★★
D1 mm	L1 mm	L2 mm	D2 mm	€	€	€
1,00	52	7	6			
2,00	54	10	6	21,15	30,97	36,11
2,50	56	12	6			
3,00	56	12	6	21,15	30,88	36,00
3,50	59	15	6	23,67	33,10	38,62
4,00	63	19	6	21,15	30,88	36,00
4,50	63	19	6	23,67	33,10	38,62
5,00	68	24	6	21,15	30,88	36,00
5,50	68	24	6	23,67	33,10	38,62
6,00	68	24	6	23,70	32,29	37,66
6,50	68	24	6			
7,00	80	30	10	32,10	43,23	50,42
7,50	80	30	10			
8,00	88	38	10	29,37	39,00	45,48
8,50	88	38	10			
9,00	88	38	10	35,73	46,26	53,96
9,50	88	38	10			
10,00	95	45	10	29,53	42,89	50,01
11,00	102	45	12	45,40*	58,41*	68,11*
12,00	110	53	12	37,56	52,28	60,98
13,00	110	53	12			
14,00	110	53	12	48,93	63,93	74,56
15,00	110	53	12			
16,00	123	63	16	55,13	77,05	89,87
17,00	123	63	16			
18,00	123	63	16	66,81	91,08	106,23
19,00	123	63	16			
20,00	141	75	20	78,43	104,22	121,52
22,00	141	75	20	98,91	134,39	156,72
25,00	166	90	25	144,15	177,54	207,04
28,00	166	90	25	160,48	212,60	247,94
30,00	166	90	25	178,67	227,09	264,83
32,00	186	106	32	212,59	255,77	298,27

FRESAS FRONTAIS SÉRIE CURTA E LONGA VARIAS NAVALHAS DIN 844 E DIN 844/L

4-6 Z



SÉRIE CURTA



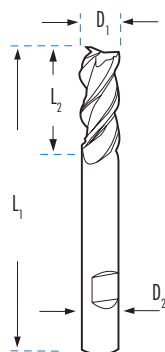

SÉRIE LONGA



DIN 844		MATERIAL		ACABAMENTO		QUALIDADE			
D1 mm	L1 mm	L2 mm	D2 mm	Z	€	€	€	€	€
1,00	49	3	6	4				29,56	35,10
2,00	51	7	6	4	15,75	24,77	28,87	21,60	29,61
2,50	52	8	6	4	15,75	24,77	28,87		
3,00	52	8	6	4	15,75	24,77	28,87	21,60	29,61
3,50	55	11	6	4	16,21	25,23	29,43		
4,00	55	11	6	4	15,75	24,77	28,87	21,60	29,61
4,50	57	13	6	4	17,31	26,16	30,49		
5,00	57	13	6	4	15,75	24,77	28,87	21,60	29,61
5,50	57	13	6	4	25,17	33,96	39,59		
6,00	57	13	6	4	16,43	25,54	29,78	21,60	29,61
6,50	66	16	10	4	25,12	35,35	41,22		
7,00	66	16	10	4	23,08	33,36	38,90	29,36	42,24
7,50	69	16	10	4	29,74	39,71	46,31		
8,00	69	19	10	4	20,31	30,91	36,05	29,23	41,83
8,50	69	19	10	4	31,01	42,00	48,98		
9,00	69	19	10	4	25,63	36,96	43,11	34,54	45,62
9,50	69	19	10	4	32,81	43,69	50,94		
10,00	72	22	10	4	22,21	33,55	39,14	31,04	42,88
11,00	79	22	12	4	30,90	43,66	50,92		
12,00	83	26	12	4	28,04	38,78	45,23	41,00	56,77
13,00	83	26	12	4	39,55	53,94	62,91		
14,00	83	26	12	4	37,33	52,62	61,38	50,94	60,48
15,00	83	26	12	4	42,63	58,81	68,59		
16,00	92	32	16	4	41,60	58,67	68,39	59,71	71,62
17,00	92	32	16	4	51,83	70,24	81,91		
18,00	92	32	16	4	51,24	71,35	83,19	72,82	89,58
19,00	92	31	16	4	60,69	80,75	94,14		
20,00	104	38	20	4	59,99	80,75	94,14	85,64	116,37
22,00	104	38	20	4	83,27	111,91	130,52	112,84	137,25
24,00	121	45	25	5	104,69	131,88	153,80		
25,00	121	45	25	5	100,07	131,26	153,08	145,60	180,98
26,00	121	45	25	5	120,12*	159,34	188,50*		
28,00	121	45	25	5	119,11	159,69	192,61		
30,00	121	45	25	6	138,47	177,25	217,00		
32,00	133	53	32	6	141,97	181,33	222,00		
36,00	133	53	32	6	215,01	260,34	318,69		
40,00	155	63	32	6	258,48*	316,61	387,57*		

*Hasta fin de existencia

FRESAS FRONTAIS DE DESBASTE VARIAS NAVALHAS DIN 844 E DIN 844/L

4-6 Z     **INOX** **Al** **TOL D1 k12** **TOL D2 h6**

SÉRIE CURTA

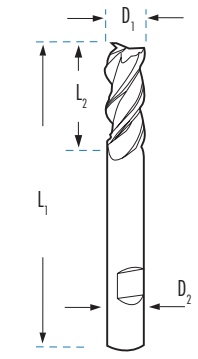

DIN 844		MATERIAL		ACABAMENTO		QUALIDADE		DESBASTE		FF25	FF27	FT25							
D1 mm	L1 mm	L2 mm	D2 mm	Z	HSSCo 8%	BRILHANTE	★★	NR	€	HSSCo 8%	TiAIN	★★★	NR	€	HSSCo 8%	TiAISIN	★★★★	NR	€
6,00	57	13	6	4					40,30					48,65					56,73
7,00	66	16	10	4					48,43					58,07					67,71
8,00	69	19	10	4					42,07					51,71					60,30
9,00	69	19	10	4					50,28					60,88					71,02
10,00	72	22	10	4					41,74					51,21					59,71
11,00	79	22	12	4					61,16					73,35					85,55
12,00	83	26	12	4					50,41					62,43					72,79
13,00	83	26	12	4					71,57					84,70					98,77
14,00	83	26	12	4					58,52					72,40					84,44
15,00	83	26	12	4					76,96					93,19					108,68
16,00	92	32	16	4					69,42					85,32					99,51
17,00	92	32	16	4					94,80					112,79					131,52
18,00	92	32	16	4					75,70					94,01					109,62
19,00	92	31	16	4					112,03					130,73					152,46
20,00	104	38	20	4					94,86					114,83					133,91
SEM CORTE AO CENTRO										FF05	FF74	FT05							
22,00	104	38	20	6					107,17					138,56					
24,00	121	45	25	6					134,99					164,31					183,36
25,00	121	45	25	6					133,72					163,36					182,30
26,00	121	45	25	6					154,86					199,90					223,06
28,00	121	45	25	6					168,93					217,48					242,68
30,00	121	45	25	6					181,47					238,05					265,63
32,00	133	53	32	6					205,59					256,03					285,69
36,00	133	53	32	6					243,66					295,03					329,23
40,00	155	63	32	6					273,93					341,64					381,24

SÉRIE LONGA



DIN 844/L		MATERIAL		ACABAMENTO		QUALIDADE		DESBASTE		FF29	FF31	FT29						
L1 mm	L2 mm	D2 mm	Z	HSSCo 8%	BRILHANTE	★★	NR	€	HSSCo 8%	TiAIN	★★★	NR	€	HSSCo 8%	TiAISIN	★★★★	NR	€
68	24	6	4					57,12					64,60					75,70
80	30	10	4					58,88*					73,81*					86,07*
88	38	10	4					59,07					68,31					79,65
88	38	10	4					64,77					74,84					87,27
95	45	10	4					51,45					63,62					74,19
102	45	12	4					84,20					96,48					112,53
110	53	12	4					63,55					76,89					89,67
110	53	12	4															
110	53	12	4					73,43					86,87					101,33
110	53	12	4															
123	63	16	4					85,96					105,42					122,93
123	63	16	4															
123	63	16	4					100,39					123,27					143,75
123	63	16	4															
141	75	20	4					122,18					145,32					169,46
										FF08	FF58	FT08						
141	75	20	6					137,62					185,63					207,15
141	75	25	6															
166	90	25	6					173,79					219,91					245,40
166	90	25	6															
166	90	25	6					195,99					252,82					282,12
166	90	25	6					254,10					302,00					337,01
186	106	32	6					265,77					308,74					344,53
186	106	32	6					319,13					368,69					411,41
217	125	32	6					377,32					458,90					512,10

*Hasta fin de existencia

FRESAS FRONTAIS, SEM CORTE AO CENTRO, VARIAS NAVALHAS DIN 844 E DIN 844/L

FRESAS

ROSCA

4-6 Z



INOX

Al

TOL D1
k10TOL D2
h6

SÉRIE CURTA

SÉRIE LONGA

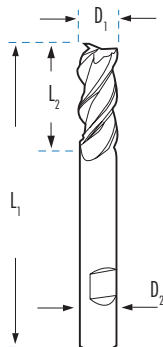

DIN 844					FF03	FF04	FF54	FT04	DIN 844/L					FF07	FF57	FT07
MATERIAL					HSS	HSSCo 8%	HSSCo 8%	HSSCo 8%	MATERIAL					HSSCo 8%	HSSCo 8%	HSSCo 8%
ACABAMENTO					BRILHANTE	BRILHANTE	TiAIN	TiAISIN	ACABAMENTO					BRILHANTE	TiAIN	TiAISIN
QUALIDADE					★	★★	★★★	★★★★	QUALIDADE					★★	★★★	★★★★
D1 mm	L1 mm	L2 mm	D2 mm	Z	€	€	€	€	L1 mm	L2 mm	D2 mm	Z	€	€	€	
2,00	51	7	6	4	11,28	14,79	23,80	27,77	54	10	6	4	18,49*	28,62*	33,53*	
2,50	52	8	6	4	11,28	14,79*	23,80*	27,77*	56	12	6	4	18,49*	26,27*	30,78*	
3,00	52	8	6	4	11,28	14,79	23,80	27,77	56	12	6	4	18,49*	29,76*	34,88*	
3,50	55	11	6	4	11,64	15,25*	24,34*	28,36*	59	15	6	4	24,33*	35,72*	41,86*	
4,00	55	11	6	4	11,28	14,79	23,89	27,84	63	19	6	4	18,49*	29,76*	34,88*	
4,50	57	13	6	4	11,64		24,34		63	19	6	4	24,33*	35,72*	41,86*	
5,00	57	13	6	4	11,28	14,79	23,89	27,84	68	24	6	4	18,49*	29,76*	34,88*	
5,50	57	13	6	4	17,53	23,00*	31,99*	37,29*	68	24	6	4	24,33*	35,72*	41,86*	
6,00	57	13	6	4	11,28	14,79	23,88	27,82	68	24	6	4	18,49*	29,76*	34,88*	
6,50	66	16	10	4	17,53*	23,00*	33,10*	38,62*	68	24	6	4				
7,00	66	16	10	4	16,55	21,73	31,90	37,19	80	30	10	4	27,99*	41,08*	48,13*	
7,50	69	16	10	4	20,74	27,18*	37,08	43,24*	80	30	10	4				
8,00	69	19	10	4	12,85	16,68	27,04	31,54	88	38	10	4	25,69*	38,71*	45,33*	
8,50	69	19	10	4	21,61				88	38	10	4				
9,00	69	19	10	4	17,31	22,68	33,88	39,51	88	38	10	4	29,06*	43,32*	50,76*	
9,50	72	22	10	4	23,46	29,99*	41,25	48,11*	88	38	10	4				
10,00	72	22	10	4	15,70	20,58	31,92	37,21	95	45	10	4	25,55*	41,19*	48,28*	
11,00	79	22	12	4	21,64	28,39	41,17	48,02	102	45	12	4	34,95*	51,98*	60,92*	
12,00	83	26	12	4	18,67	24,56	37,04	43,19	110	53	12	4	32,46*	49,44*	57,93*	
13,00	83	26	12	4	27,83	36,65	50,46	58,83	110	53	12	4				
14,00	83	26	12	4	26,33	34,46	48,54	56,60	110	53	12	4	42,43*	59,98*	70,28*	
15,00	83	26	12	4	30,01	39,33	55,90	65,18	110	53	12	4				
16,00	92	32	16	4	29,29	38,36	54,98	64,11	123	63	16	4	46,37*	70,91*	83,09*	
17,00	92	32	16	4	36,08	47,49	65,74	76,66	123	63	16	4				
18,00	92	32	16	4	36,04	47,29	65,74	76,66	123	63	16	4	56,64*	84,26*	98,72*	
19,00	92	31	16	4	42,68	55,64	75,42	87,97	123	63	16	4				
20,00	104	38	20	4	42,24	55,64	75,42	87,97	141	75	20	4	66,33*	96,69*	113,29*	
22,00	104	38	20	4	58,65	77,22	104,40	121,75	141	75	20	5	91,99*	127,09	148,92	
24,00	121	45	25	5	72,84	95,96	122,72	143,11	141	75	25	5				
25,00	121	45	25	5	72,60	95,96	122,72	143,11	166	90	25	5	122,01*	162,72*	190,65*	
26,00	121	45	25	5	91,06	119,96*	155,14*	180,91*	166	90	25	5				
28,00	121	45	25	5	91,06	119,96	159,33	185,79	166	90	25	5	149,13*	200,38*	234,79*	
30,00	121	45	25	6	105,57	138,28	177,66	207,19	166	90	25	6	170,68*	222,15*	260,27*	
32,00	133	53	32	6	108,58	141,85	181,79	212,00	186	106	32	6	170,41*	223,71*	262,11*	
36,00	133	53	32	6	142,08	187,13	227,64	265,45	186	106	32	6	243,05*	307,38*	360,16*	
40,00	143	63	32	6	170,34	224,93	279,34	325,76	217	125	32	6	270,17*	413,11*	484,05*	

*Hasta fin de existencia

FRESAS FRONTAIS DE DESBASTE VARIAS NAVALHAS DIN 844 E DIN 844/L

3-5 Z   **30° N**  **WELDON**  **34 HRC**  **INOX**  **Al** **TOL D1 k12** **TOL D2 h6**

SÉRIE CURTA

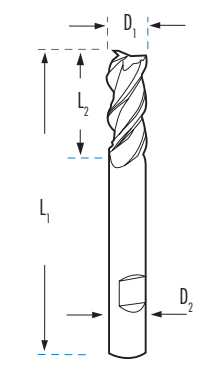

SÉRIE LONGA



DIN 844		MATERIAL				FP10	FT10	FP11	FT11
ACABAMENTO		ASP 60				ASP 60	ASP 60	ASP 60	ASP 60
DESABASTE		BRILHANTE				BRILHANTE	TiAlSiN	BRILHANTE	TiAlSiN
QUALIDADE		NF				NF	NF	NR	NR
		Premium Quality				Premium Quality	Premium Quality	Premium Quality	Premium Quality
D1 mm	L1 mm	L2 mm	D2 mm	Z	€	€	€	€	
2,00	51	7	6	3					
2,50	52	8	6	3					
3,00	52	8	6	3					
3,50	55	11	6	3					
4,00	55	11	6	3					
4,50	57	13	6	3					
5,00	57	13	6	3					
5,50	57	13	6	3					
6,00	57	13	6	3	50,47	57,92	46,77	53,78	
6,50	66	16	10	3					
7,00	66	16	10	3	64,72	70,47	58,72 *	66,82 *	
7,50	69	19	10	3					
8,00	69	19	10	3	55,74	64,93	51,11	59,04	
8,50	69	19	10	3					
9,00	69	19	10	3	67,14	73,52	61,08 *	69,88 *	
9,50	72	22	10	3					
10,00	72	22	10	4	53,15	63,00	48,18	59,83	
11,00	79	22	12	4					
12,00	83	26	12	4	69,92	79,19	63,75	72,95	
13,00	83	26	12	4					
14,00	83	26	12	4	84,91	96,53	76,98	87,54	
15,00	83	26	12	4					
16,00	92	32	16	4	104,08	114,76	94,90	106,92	
17,00	92	32	16	4					
18,00	92	32	16	4	114,28	124,79	102,97	116,95	
19,00	92	31	16	4					
20,00	104	38	20	4	141,76	156,28	128,14	146,61	
22,00	104	38	20	5	174,76	192,54	158,48	180,11	
24,00	121	45	25	5					
25,00	121	45	25	5	207,16	230,18	187,91	213,19	
26,00	121	45	25	5					
28,00	121	45	25	5					
30,00	121	45	25	5					
32,00	133	53	32	5					
36,00	133	53	32	5					
40,00	155	63	32	5					

DIN 844/L		MATERIAL				FP15	FT15	FP13	FT13
ACABAMENTO		ASP 60				ASP 60	ASP 60	ASP 60	ASP 60
DESABASTE		BRILHANTE				BRILHANTE	TiAlSiN	BRILHANTE	TiAlSiN
QUALIDADE		NF				NF	NF	NR	NR
		Premium Quality				Premium Quality	Premium Quality	Premium Quality	Premium Quality
L1 mm	L2 mm	D2 mm	Z		€	€	€	€	
54	10	6	3						
56	12	6	3						
56	12	6	3						
59	15	6	3						
63	19	6	3						
63	19	6	3						
68	24	6	3						
68	24	6	3						
68	24	6	3		79,20	83,67	70,25	77,31	
68	24	6	3						
80	30	10	3		89,53	101,93	81,31	94,95	
80	30	10	3						
88	38	10	3		83,30	88,66	73,74	82,59*	
88	38	10	3						
88	38	10	3		87,87*	100,56	81,31	95,56	
88	38	10	3						
95	45	10	4		74,95	83,36	66,79	76,97	
102	45	12	4						
110	53	12	4		94,98	103,76	83,89	94,98	
110	53	12	4						
110	53	12	4		111,33	127,74	100,12	113,06	
110	53	12	4						
123	63	16	4		133,17	146,28	118,82	134,97	
123	63	16	4						
123	63	16	4		148,96	173,45	135,71*	154,63*	
123	63	16	4						
141	75	20	4		193,63	212,40	171,55	197,49	
141	75	20	5		295,83	316,13	259,04	286,78	
141	75	25	5						
166	90	25	5		297,06	326,15	262,04	303,94	
166	90	25	5						
166	90	25	5						
166	90	25	5						
186	106	32	5						
186	106	32	5						
217	125	32	5						

FRESAS FRONTAIS SÉRIE SUPER-CURTA E EXTRA-CURTA DE 3 NAVALHAS
3 Z

INOX
Al
**TOL D1
e8**
**TOL D2
h6**
SÉRIE SUPER-CURTA
SÉRIE EXTRA-CURTA

MATERIAL ACABAMENTO					FF51
					HSSCo 8%
					BRILHANTE
D1 mm	L1 mm	L2 mm	D2 mm	Z	€
1,00	34	2	6	3	15,06
1,50	34	3	6	3	15,06
2,00	35	4	6	3	15,03
2,50	36	5	6	3	15,03
3,00	36	5	6	3	15,03
3,50	37	6	6	3	15,03
4,00	38	7	6	3	15,03
4,50	38	7	6	3	15,03
5,00	39	8	6	3	15,03
5,50	39	8	6	3	15,03
6,00	39	8	6	3	15,03
6,50	42	10	8	3	20,66
7,00	42	10	8	3	20,66
7,50	42	10	8	3	20,66
8,00	43	11	8	3	20,66
8,50	48	11	10	3	23,68
9,00	48	11	10	3	23,68
9,50	48	11	10	3	23,68
10,00	50	13	10	3	23,68



MATERIAL ACABAMENTO					FF53
					HSSCo 8%
					BRILHANTE
D1 mm	L1 mm	L2 mm	D2 mm	Z	€
2,00	38	7	6	3	16,48
2,50	39	8	6	3	16,48
3,00	39	8	6	3	16,48
3,50	41	10	6	3	16,48
4,00	42	11	6	3	16,48
4,50	42	11	6	3	16,48
5,00	44	13	6	3	16,48
5,50	44	13	6	3	16,48
6,00	44	13	6	3	16,48
6,50	48	16	8	3	22,68
7,00	48	16	8	3	22,68
8,00	51	19	8	3	22,68
8,50	56	19	10	3	25,94
9,00	56	19	10	3	25,94
10,00	59	22	10	3	25,94



FRESAS DE METAL DURO PARA MATERIAIS COMPOSTOS: FIBRA DE CARBONO, PAINEL FENÓLICO, ETC...



REVOLUÇÕES E AVANÇOS

D ₁ mm	RPM rev./min	AVANÇO mm/min
1.50	60.000	3.000
2.00	50.000	2.500
3.00	32.000	1.600
5.00	20.000	1.200
6.00	16.000	1.000
6.35	14.000	1.000
8.00	9.000	700
10.00	7.000	550
12.00	6.000	450



D ₁ mm	L ₁ mm	L ₂ mm	D ₂ mm		RFC		RFC150TL		RF		RF150TL		RFF		RFF150TL		
					€	TiAlN	€	TiAlN	€	TiAlN	€	TiAlN	€	TiAlN			
1,50	38	5	3,00	RFC0150	19,38		RFC0150TL	29,29	RF0150	18,37		RF0150TL	28,28	RFF0150		RFF0150TL	
2,00	38	10	3,00	RFC0200	19,38		RFC0200TL	29,29	RF0200	18,37		RF0200TL	28,28	RFF0200		RFF0200TL	
3,00	38	12	3,00	RFC0300	19,38		RFC0300TL	29,29	RF0300	18,37		RF0300TL	28,28	RFF0300	19,38	RFF0300TL	29,29
5,00	50	16	5,00	RFC0500	38,46		RFC0500TL	48,39	RF0500	34,93		RF0500TL	44,84	RFF0500	38,46	RFF0500TL	48,39
6,00	63	25	6,00	RFC0600	45,74		RFC0600TL	57,79	RF0600	41,46		RF0600TL	53,54	RFF0600	45,74	RFF0600TL	57,79
6,35	75	30	6,35	RFC0635	50,78		RFC0635TL	62,88	RF0635	46,49		RF0635TL	58,56	RFF0635	50,78	RFF0635TL	62,88
8,00	63	25	8,00	RFC0800	76,15		RFC0800TL	87,56	RF0800	69,13		RF0800TL	80,51	RFF0800	76,15	RFF0800TL	87,56
10,00	63	25	10,00	RFC1000	96,74		RFC1000TL	108,71	RF1000	87,97		RF1000TL	99,93	RFF1000	96,74	RFF1000TL	108,71
12,00	75	25	12,00	RFC1200	121,62		RFC1200TL	136,45	RF1200	110,60		RF1200TL	125,40	RFF1200	121,62	RFF1200TL	136,45

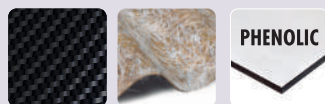

Geometria multicorte adaptada à maquinação de materiais compostos, para evitar a delaminação da fibra de carbono e da fibra de vidro. Válido para transformação de Painel Fenólico.

REVOLUÇÕES E AVANÇOS

D ₁ mm	RPM rev./min	AVANÇO mm/min
3,00	15.000	2.250
4,00	12.000	1.800
5,00	10.000	1.800
6,00	8.500	1.700
8,00	6.500	1.950
10,00	5.500	1.650
12,00	4.500	1.550



D ₁ mm	L ₁ mm	L ₂ mm	D ₂ mm	FC11		FC12		FC13		FC14	
				Direita	€	Reta	€	Esquerda	€	Bola	€
3,00	45	10	3,00	FC1133	34,95	FC1233	34,95	FC1333	34,95	FC1433	36,47
3,00	60	10	6,00	FC1136	39,89	FC1236	39,89	FC1336	39,89	FC1436	39,89
4,00	60	15	4,00	FC1144	45,59	FC1244	45,59	FC1344	45,59	FC1444	49,01
4,00	60	15	6,00	FC1146	72,18	FC1246	72,18	FC1346	45,59	FC1446	73,70
5,00	60	15	5,00	FC1155	61,16	FC1255	61,16	FC1355	61,16	FC1455	61,16
6,00	70	25	6,00	FC1166	74,46	FC1266	74,46	FC1366	74,46	FC1466	70,28
8,00	80	30	8,00	FC1188	113,97	FC1288	113,97	FC1388	113,97	FC1488	122,32
10,00	80	35	10,00	FC111010	170,95	FC121010	170,95	FC131010	170,95	FC141010	170,95
12,00	90	40	12,00	FC111212	227,55	FC121212	227,55	FC131212	227,55	FC141212	235,53

FRESAS DE 1 NAVALHA HSSCo

HSSCo

Al

PVC

TOL D1
k12TOL D2
h6
SÉRIE CURTA

FF13

	D1 mm	L1 mm	L2 mm	D2 mm	HSSCo €	TiN €
FF1381	1,0	60	10	8	46,49	65,48
FF1382	2,0	60	10	8	46,49	65,48
FF1383	3,0	60	10	8	17,71	25,84
FF1384	4,0	60	12	8	17,71	25,84
FF1385	5,0	60	13	8	17,71	25,84
FF1386	6,0	60	14	8	18,69	26,78
FF1387	7,0	60	14	8	21,61	30,39
FF1388	8,0	80	14	8	21,61	30,39
FF131010	10,0	80	15	10	23,97	31,49
FF131212	12,0	80	35	12	58,70	73,37
FF131414	14,0	100	40	12	70,79	88,49
FF131616	16,0	100	40	16	75,61	94,51
FF132020	20,0	100	40	20	85,71	107,14
FF1361	1,0	45	6	6	32,45	43,02
FF13615	1,5	45	6	6	32,45	43,02
FF1362	2,0	45	6	6	32,45	43,02
FF1363	3,0	60	12	6	16,81	23,57
FF1364	4,0	60	12	6	16,86	23,57
FF1365	5,0	60	12	6	16,86	23,57
FF1366	6,0	60	14	6	16,86	23,57

ALUMÍNIO LACADO

FF50

	D1 mm	L1 mm	L2 mm	L3 mm	D2 mm	HSSCo €	TiN €
FF5084	4	80	16	35	8	23,57	32,16
FF5085	5	80	18	35	8	23,57	32,16

MEDIDAS ESPECIAIS
FF14 Especiais

	D1 mm	L1 mm	L2 mm	L3 mm	D2 mm	HSSCo €
FF148412020	4	120	20	-	8	28,42
FF14856018	5	60	18	-	8	23,43
FF14859025	5	90	25	-	8	30,57
FF148510025	5	100	25	-	8	28,41
FF148512014	5	120	14	-	8	28,41
FF14851001817	5	100	18	35	8	28,87
FF14851201461	5	120	14	75	8	38,87
FF14851201817	5	120	18	35	8	38,87
FF1486801421	6	80	14	35	8	32,20
FF14861001835	6	100	18	35	8	32,20
FF14861201461	6	120	14	75	8	46,58

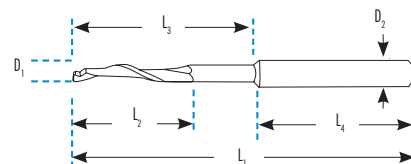
SÉRIE LONGA

FF14

	D1 mm	L1 mm	L2 mm	L3 mm	D2 mm	HSSCo €	TiN €
FF1483	3	80	16	45	8	30,48	38,69
FF1484	4	80	16	45	8	26,20	34,35
FF1485	5	80	16	45	8	26,20	34,35
FF1486	6	90	16	45	8	26,20	34,35
FF1487	7	90	20	50	8	33,60	42,36
FF1488	8	100	30	70	8	30,38	39,05
FF1465	5	80	14	45	6	25,93	34,35
FF1466	6	80	14	45	6	25,95	34,35

SÉRIE EXTRA-LONGA

FF14-E

	D1 mm	L1 mm	L2 mm	L3 mm	D2 mm	L4 mm	HSSCo €	TiN €
FF1485-E	5	100	30	55	8	45	25,41	31,81
FF1485-EL	5	100	50	-	8	50	30,42	43,20

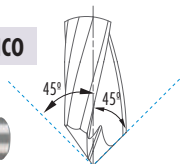
FRESA 1 NAVALHA COM PONTA PARA PERFURAÇÃO EM PERFIL METÁLICO

FF14

	D1 mm	L1 mm	L3 mm	D2 mm	HSSCo €	TiN €
FF14848040	4	80	40	8	61,22	70,40
FF148411040	4	110	40	8	81,49	93,72
FF14858040	5	80	40	8	59,92	68,91
FF148511040	5	110	40	8	83,18	95,66
FF14868040	6	80	40	8	50,29	57,84
FF148611040	6	110	40	8	83,18	95,66

FF14 Especiais

	D1 mm	L1 mm	L2 mm	L3 mm	D2 mm	HSSCo €
FF14861003045	6	100	30	45	8	39,07
FF14861006040	6	100	60	-	8	50,15
FF14888025	8	80	25	-	8	25,37
FF148810014	8	100	14	-	8	28,06
FF148812014	8	120	14	-	8	30,46
FF14881201476	8	120	14	90	8	36,76
FF14898014	9	80	14	-	8	29,42
FF148108014	10	80	14	-	8	31,32
FF1410101003040	10	100	30	70	10	38,23
FF1410101201481	10	120	14	95	10	40,72
FF14101012014	10	120	14	-	10	32,82
FF148128014	12	80	14	-	8	35,52

FRESAS DE 1 NAVALHA DE METAL DURO

MD **Al** PVC TOL h10 TOL D2 h6

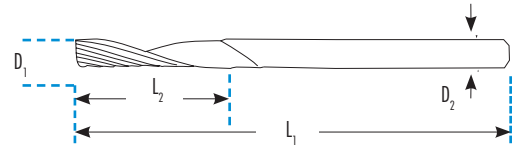

HÉLICE A - SÉRIE CURTA



HÉLICE A - SÉRIE LONGA



Hélice A	D1 mm	L1 mm	L2 mm	D2 mm	FMGA13	
					MD	€
FMGA13305	0,5	39	1,5	3	MD	54,01
FMGA1331	1,0	39	3,0	3	MD	41,40
FMGA13315	1,5	39	4,0	3	MD	37,26
FMGA1322	2,0	40	10,0	2	MD	31,40
FMGA13325	2,5	40	12,0	3	MD	31,40
FMGA1333	3,0	40	12,0	3	MD	26,59
FMGA1336	3,0	64	12,0	6	MD	46,52
FMGA1338	3,0	64	12,0	8	MD	67,38
FMGA1344	4,0	50	16,0	4	MD	29,23
FMGA1346	4,0	64	16,0	6	MD	46,99
FMGA1348	4,0	64	16,0	8	MD	78,41
FMGA135550	5,0	50	16,0	5	MD	30,34
FMGA1355	5,0	64	16,0	5	MD	33,24
FMGA1356	5,0	64	16,0	6	MD	52,89
FMGA1358	5,0	64	16,0	8	MD	80,18
FMGA136650	6,0	50	16,0	6	MD	40,79
FMGA1366	6,0	64	20,0	6	MD	44,94
FMGA1368	6,0	64	20,0	8	MD	81,40
FMGA1378	7,0	64	20,0	8	MD	91,26
FMGA138816	8,0	66	16,0	8	MD	46,27
FMGA1388	8,0	76	38,0	8	MD	61,36
FMGA13101015	10,0	76	15,0	10	MD	72,36
FMGA131010	10,0	76	30,0	10	MD	76,90

Hélice A	D1 mm	L1 mm	L2 mm	D2 mm	FMGA13E	
					MD	€
FMGA133312E	3	70	12	3	MD	30,75
FMGA133322E	3	70	22	3	MD	32,05
FMGA133332E	3	70	32	3	MD	34,11
FMGA134415E	4	70	15	4	MD	39,99
FMGA134425E	4	70	25	4	MD	42,36
FMGA134435E	4	70	35	4	MD	45,25
FMGA135517E	5	80	17	5	MD	52,36
FMGA1355E	5	80	38	5	MD	58,59
FMGA136620E	6	85	20	6	MD	58,36
FMGA1366E	6	85	40	6	MD	64,71
FMGA138825E	8	90	25	8	MD	78,36
FMGA1388E	8	90	38	8	MD	83,18
FMGA1388EX	8	110	43	8	MD	109,13
FMGA131010E	10	100	40	10	MD	119,26
FMGA131010EL	10	120	60	10	MD	154,59

HÉLICE A - COM COLARINHO



Hélice A	D1 mm	L1 mm	L2 mm	D2 mm	FMGA13	
					MD	€
FMGA13488016	4	8	80	16	29	69,95
FMGA13588016	5	8	80	16	29	69,95
FMGA13689016	6	8	90	16	29	69,95

VELOCIDADES DE CORTE

D1 mm	HSSCo		MD	
	Aluminio (R.P.M.)	PVC (R.P.M.)	Aluminio (R.P.M.)	PVC (R.P.M.)
3,00	12000	12000	19000	19000
4,00	11000	11000	18000	18000
5,00	10000	10000	18000	18000
6,00	10000	10000	17000	17000
7,00	9000	9000	17000	17000
8,00	9000	9000	16000	16000
9,00	9000	9000	16000	16000
10,00	9000	9000	16000	16000

NOTA: para a serie longa convém reduzir as RPM num 15%.

FRESAS DE 1 NAVALHA DE METAL DURO

MD

Al

PVC

TOL

h10

TOL D2

h6

HÉLICE B



 B	D1 mm	L1 mm	L2 mm	D2 mm	FMGA13HI
					MD
					€
FMGA1333HI	3	50	8	3	34,64
FMGA1344HI	4	64	12	4	34,64
FMGA1355HI	5	64	16	5	37,51
FMGA1366HI	6	64	20	6	56,63
FMGA1388HI	8	76	38	8	74,94
FMGA13101HI	10	76	35	10	91,60

CANAL RETO

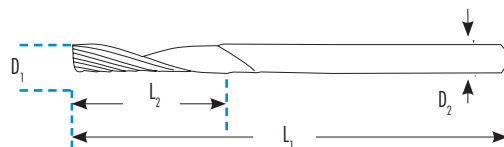
 R	D1 mm	L1 mm	L2 mm	D2 mm	FMGA13R
					MD
					€
FMGA1346R	4	64	16	6	50,76
FMGA1356R	5	64	20	6	50,76
FMGA1366R	6	64	25	6	59,10
FMGA1388R	8	64	25	8	87,42
FMGA13101OR	10	88	35	10	114,42
FMGA131212R	12	88	35	12	165,14

HÉLICE C

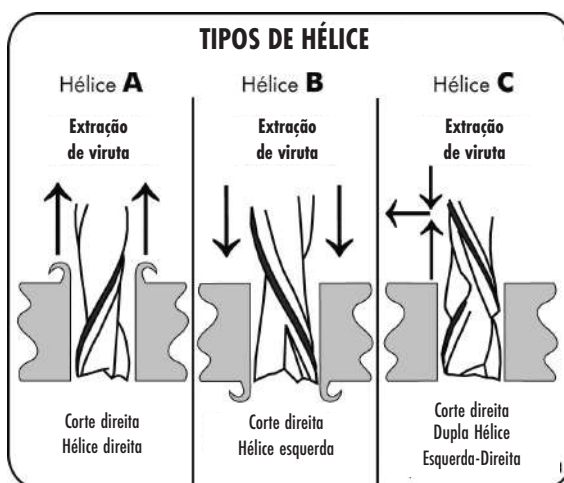
 C	D1 mm	L1 mm	L2 mm	D2 mm	FMGA13CO
					MD
					€
FMGA1366CO	6	64	25	6	137,28
FMGA1388CO	8	64	25	8	189,83
FMGA13101OCO	10	76	35	10	223,12
FMGA131212CO	12	76	35	12	296,00

TIPOS DE HÉLICE

FRESAS DE METAL DURO PARA REPARAÇÃO DE FUROS DE PNEUS

MD



	D1 mm	L1 mm	L2 mm	D2 mm	RN
					€
RN0300	3,00	50	25	3	18,86
RN0600	6,00	80	50	6	45,51
RN0800	8,00	110	50	8	51,25
RN1000	10,00	110	60	10	80,43

FRESAS DE METAL DURO ACESSÓRIOS TIPO ROTOZIP

Ref.: RR0317



Ref.: RR0635



Ref.: RR0435



Ref.: RR0247

		D1 mm	L1 mm	L2 mm	D2 mm	RR
						€
RR0317	Cortador Azulejo	3,17	50	25	3,17	21,75*
RR0635	Cortador Azulejo	6,35	50	25	6,35	36,45*
RR0435	Trabalhos Em Gesso	6,35	52	32	6,35	45,61*
RR0247	Argamassa	2,47	38	14	3,17	15,98*

*Até o fim das existências.

FRESAS PARA FAZER RANHURA

Ref. FF17

RANHURAR EN "T" DIN 851A



TOL D1
d11

TOL D2
h6

FF17						
D1 x L2 mm	D2 mm	D3 mm	Z	L1 mm	HSSCo €	TiAIN €
11,0x4,0	10	4	4	53,5	106,12	130,40
12,5x6,0	10	5	6	57,0	110,31	137,91
16,0x8,0	10	7	6	62,0	121,30	153,89
18,0x8,0	12	8	8	70,0	127,77	164,54
21,0x9,0	12	10	8	74,0	140,72	197,66
25,0x11,0	16	12	8	82,0	158,82	215,25
32,0x14,0	16	15	10	90,0	200,34	279,15
40,0x18,0	25	19	10	108,0	277,89	389,15
50,0x22,0	32	25	10	124,0	334,15	438,22
60,0x28,0	32	30	10	139,0	349,30	458,13
72,0x35,0	32	35	10	153,0	364,49	478,05

Ref. FF17C

RANHURAR EN "T" DIN 851B



TOL D2
h12

FF17C						
D1 x L2 mm	CM	ROSCA	D2 mm	L1 mm	HSSCo €	TiAIN €
18,0x8,0	1	M6	8	70	139,21	172,62
21,0x9,0	2	M10	10	74	152,85	189,53
25,0x11,0	2	M10	12	82	159,35	197,60
32,0x14,0	2	M10	16	90	212,52	263,53
40,0x18,0	3	M12	20	108	268,68	333,16
50,0x22,0	4	M16	25	124	354,87	440,02
60,0x28,0	4	M16	31	139	469,53	582,21
72,0x35,0	5	M20	36	153	637,31	790,25

FRESA DE 1/4 DE CIRCULO PARA ARREIMATE DE ARESTAS

4 Z

HSSCo 8% DIN 6518N WELDON

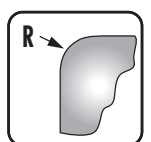
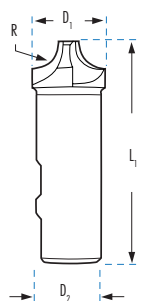

FF1/4R					
	TOL H11 R	js 15 D1 mm	TOL h6 D2 mm	L1 mm	€
FF1/4R1	1,0	8	10	60	74,32
FF1/4R1.50	1,5	9	10	60	71,88
FF1/4R2	2,0	10	10	60	60,48
FF1/4R2.50	2,5	11	10	60	69,58
FF1/4R3	3,0	12	12	60	69,32
FF1/4R3.50	3,5	13	12	60	90,28
FF1/4R4	4,0	14	12	60	76,98
FF1/4R4.50	4,5	15	12	60	102,90
FF1/4R5	5,0	16	12	60	86,26
FF1/4R5.50	5,5	19	16	67	102,90
FF1/4R6	6,0	20	16	67	86,41
FF1/4R6.50	6,5	21	16	71	130,97
FF1/4R7	7,0	22	16	71	118,09
FF1/4R7.50	7,5	23	16	71	142,56
FF1/4R8	8,0	24	16	71	118,09
FF1/4R8.50	8,5	25	25	85	174,63
FF1/4R9	9,0	26	25	85	153,91
FF1/4R9.50	9,5	27	25	85	183,53
FF1/4R10	10,0	28	25	85	153,91
FF1/4R10.50	10,5	31	25	90	213,82
FF1/4R11	11,0	32	25	90	205,48
FF1/4R12	12,0	34	25	90	169,30
FF1/4R12.50	12,5	41	25	100	219,87
FF1/4R13	13,0	42	25	100	272,54
FF1/4R14	14,0	44	25	100	282,80
FF1/4R15	15,0	46	25	100	352,06
FF1/4R16	16,0	48	25	100	323,59
FF1/4R18	18,0	52	32	112	417,39
FF1/4R20	20,0	56	32	112	468,92

FRESA PARA FAZER RANHURA "WOODRUFF"

Ref. FF16

TIPO WOODRUFF DIN 850B

TOL D1 h12 TOL D2 h6

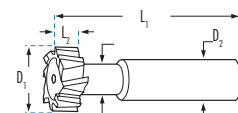

FF16					
D1 x L2 mm	D2 mm	Z	L1 mm	HSSCo €	TiAIN €
4,5x1,0	6	6	50	60,33	71,35
7,5x1,5	6	6	50	62,82	75,50
7,5x2,0	6	6	50	62,82	75,50
10,5x2,0	6	6	50	67,58	81,47
10,5x2,5	6	6	50	67,58	81,47
10,5x3,0	6	6	50	67,58	81,47
13,5x3,0	10	6	56	68,65	85,76
13,5x4,0	10	6	56	68,65	85,76
16,5x3,0	10	6	56	69,27	91,83
16,5x4,0	10	6	56	69,27	91,83
16,5x5,0	10	6	56	69,27	88,84
19,5x4,0	10	8	63	78,86	104,18
19,5x5,0	10	8	63	78,86	99,82
19,5x6,0	10	8	63	78,86	99,82
22,5x5,0	10	8	63	86,38	115,71
22,5x6,0	10	8	63	86,38	116,28
22,5x8,0	10	8	63	86,38	116,28
25,5x6,0	10	10	63	101,16	144,01
28,5x6,0	10	10	63	102,91	145,74
28,5x8,0	10	10	63	102,91	145,74
28,5x10,0	12	10	71	102,91	145,74
32,5x7,0	12	10	71	127,62	174,41
32,5x8,0	12	10	71	127,62	174,41
32,5x10,0	12	10	71	127,62	174,41
45,5x10,0	12	12	71	201,88	287,01

FRESAS CÓNICAS ANGULARES HSSCo COM CABO CILÍNDRICO HSSCo

 Ref. FF98
 Ref. FF99

HSSCo
**DIN
1833A**
**TOL D1
js16**
**TOL D2
h6**

 Ref. FF97
 Ref. FF95

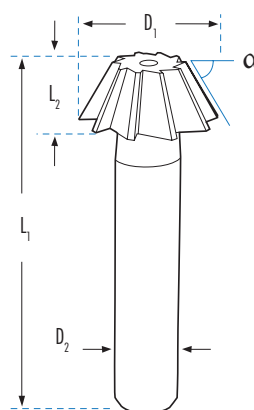
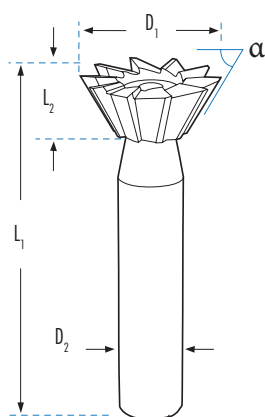
HSSCo
**DIN
1833B**
**TOL D1
js16**
**TOL D2
h6**

FF98

45°	D1 mm	α	D2 mm	L1 mm	L2 mm	Z	€
FF981600	16	45°	12	60	4,0	8	107,32
FF982000	20	45°	12	63	5,0	10	113,79
FF982500	25	45°	12	67	6,3	12	139,13
FF983200	32	45°	16	71	8,0	14	155,25

FF97

45°	D1 mm	α	D2 mm	L1 mm	L2 mm	Z	€
FF971600	16	45°	12	60	4,0	8	86,40
FF972000	20	45°	12	63	5,0	10	97,16
FF972500	25	45°	12	67	6,3	12	109,25
FF973200	32	45°	16	71	8,0	12	124,24

FF99

60°	D1 mm	α	D2 mm	L1 mm	L2 mm	Z	€
FF991600	16	60°	12	60	6,3	8	107,28
FF992000	20	60°	12	63	8,0	10	113,74
FF992500	25	60°	12	67	10,0	12	139,11
FF993200	32	60°	16	71	12,5	14	155,22

FF95

60°	D1 mm	α	D2 mm	L1 mm	L2 mm	Z	€
FF951600	16	60°	12	60	6,3	8	84,76
FF952000	20	60°	12	63	8,0	10	95,33
FF952500	25	60°	12	67	10,0	12	107,21
FF953200	32	60°	16	71	12,5	12	121,92







MEDIDAS ESPECIAIS
FF99

FF991600-50	16	50°	12	60	5,0	8	120,47
FF992000-50	20	50°	12	63	6,3	10	128,42
FF992500-50	25	50°	12	67	8,0	12	158,67
FF991600-55	16	55°	12	60	5,6	8	120,47
FF992000-55	20	55°	12	63	7,1	10	128,42
FF992500-55	25	55°	12	67	9,0	12	158,67
FF991600-75	16	75°	12	60	8,0	8	120,47
FF992500-75	25	75°	12	67	10,0	12	158,67
FF991600-80	16	80°	12	60	8,0	8	120,47
FF992500-80	25	80°	12	67	10,0	12	158,67
FF991600-85	16	85°	12	60	8,0	8	120,47
FF992500-85	25	85°	12	67	10,0	12	158,67

MEDIDAS ESPECIAIS
FF95

FF951600-50	16	50°	12	60	5,0	8	100,58
FF952000-50	20	50°	12	63	6,3	10	128,40
FF952500-50	25	50°	12	67	8,0	12	160,19
FF951600-55	16	55°	12	60	5,6	8	100,58
FF952000-55	20	55°	12	63	7,1	10	128,40
FF952500-55	25	55°	12	67	9,0	12	160,19
FF951600-75	16	75°	12	60	8,0	8	100,58
FF952500-75	25	75°	12	67	10,0	12	160,19

FRESAS FRONTAIS COM CABO CÔNICO SÉRIE CURTA

4-8 Z      **2 Z** 

SÉRIE CURTA

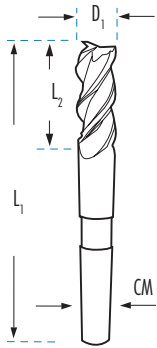

DIN 845B		MATERIAL				ACABAMENTO						QUALIDADE			DESABASTE		DIN 326						
D1 mm	L1 mm	L2 mm	Z	CM	ROSCA	HSSCo 8% BRILHANTE ★★	HSSCo 8% TiN ★★★	HSSCo 8% TiAlN ★★★	HSSCo 8% BRILHANTE ★★	HSSCo 8% TiN ★★★	HSSCo 8% TiAlN ★★★	L1 mm	L2 mm	Z	HSSCo 8% BRILHANTE	TOL k10	TOL k10	TOL k10	TOL k12	TOL k12	TOL k12	TOL e8	€
10,00	92	22	4	1	M6	€ 56,26	€ 78,12	€ 80,45	€ 83,46	€ 104,26	€ 107,30	83	13	2	€ 70,74								
12,00	111	26	4	2	M6	€ 74,38	€ 95,42	€ 100,02	€ 85,06	€ 106,46	€ 110,58	86	16	2	€ 73,44								
14,00	111	26	4	2	M10	€ 82,41	€ 104,49	€ 110,53	€ 96,64	€ 118,96	€ 124,74	101	16	2	€ 76,20								
15,00	111	26	4	2	M10	€ 88,43	€ 114,37	€ 119,88	€ 120,72	€ 145,44	€ 152,52												
16,00	117	32	4	2	M10	€ 82,05	€ 108,46	€ 113,68	€ 99,67	€ 126,08	€ 130,96	104	19	2	€ 83,26								
18,00	117	32	4	2	M10	€ 87,15	€ 113,20	€ 118,64	€ 109,39	€ 135,01	€ 141,60	104	19	2	€ 87,28								
20,00	123	38	4	2	M10	€ 97,22	€ 127,47	€ 133,62	€ 120,31	€ 150,13	€ 157,45	107	22	2	€ 91,59								
22,00	123	38	5	2	M10	€ 109,95	€ 138,68	€ 146,70	€ 132,44	€ 161,34	€ 169,17	107	22	2	€ 107,87								
24,00	147	45	6	3	M12	€ 166,29	€ 190,79	€ 203,72	€ 184,66	€ 211,75	€ 222,03	128	26	2	€ 139,57								
25,00	154	45	5	3	M12	€ 150,09	€ 184,60	€ 195,34	€ 184,71	€ 219,32	€ 229,98	128	26	2	€ 146,69								
26,00	147	45	6	3	M12	€ 151,56	€ 191,68	€ 195,34	€ 202,91	€ 236,05	€ 247,56	128	26	2	€ 140,00*								
28,00	154	50	5	3	M12	€ 151,56	€ 191,68	€ 195,34	€ 202,97	€ 236,05	€ 247,56	128	26	2	€ 170,03								
30,00	154	50	6	3	M12	€ 167,47	€ 220,24	€ 224,42	€ 238,32	€ 281,90	€ 295,63	128	26	2	€ 187,18								
32,00	178	53	6	4	M16	€ 219,99	€ 282,60	€ 287,99	€ 282,59	€ 348,71	€ 365,65	157	32	2	€ 206,10								
36,00	178	53	6	4	M16	€ 250,58	€ 313,00	€ 322,12	€ 311,53	€ 378,52	€ 396,93	157	32	2	€ 262,88								
40,00	188	63	6	4	M16	€ 301,89	€ 375,65	€ 386,56	€ 435,20	€ 512,28	€ 537,18	163	38	2	€ 302,96								
45,00	188	63	6	4	M16	€ 388,81	€ 476,04	€ 489,74	€ 494,66	€ 566,44	€ 593,98	163	38	2	€ 437,56								
50,00	233	75	6	5	M20	€ 468,40	€ 550,10	€ 565,96	€ 524,60	€ 617,64	€ 647,64	203	45	2	€ 549,69								
56,00	233	75	8	5	M20	€ 646,16	€ 715,59	€ 736,21	€ 746,99	€ 798,30	€ 837,11												
63,00	241	90	8	5	M20	€ 811,25	€ 869,30	€ 894,34	€ 938,23	€ 974,02	€ 1.021,34												

*Até o fim das existências.

FRESAS FRONTAIS COM CABO CÔNICO SÉRIE LONGA DIN 845B/L

4-8 Z



INOX

Al

SÉRIE LONGA

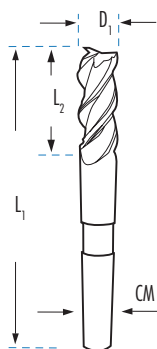

DIN 845B/L						MATERIAL					
						ACABAMENTO					
DESABASTE						FF11	FF61	FF71	FF12	FF33	FF43
						HSSCo 8%	HSSCo 8%	HSSCo 8%	HSSCo 8%	HSSCo 8%	HSSCo 8%
						BRILHANTE	TiN	TiAlN	BRILHANTE	TiN	TiAlN
						★★	★★★	★★★	★★	★★★	★★★
						TOL k10	TOL k10	TOL k10	TOL k12	TOL k12	TOL k12
D1 mm	L1 mm	L2 mm	Z	CM	ROSCA	€	€	€	€	€	€
10,00	115	45	4	1	M6	102,20	124,56	128,78	149,16	170,45	176,24
12,00	138	53	4	2	M6	96,36	124,56	132,43	151,95	172,69	180,21
14,00	138	53	4	2	M10	101,40	135,31	141,20	191,45	211,93	221,18
15,00	138	53	4	2	M10	111,32	141,86	148,02	220,17	243,51	254,17
16,00	148	63	4	2	M10	110,19	138,30	144,33	159,24	185,93	194,05
18,00	148	63	4	2	M10	125,18	151,82	158,41	165,30	191,69	200,05
20,00	160	75	4	2	M10	138,89	169,83	177,22	189,62	219,95	229,53
22,00	160	75	5	2	M10	157,19	186,86	195,89	196,94	226,82	236,71
24,00	192	90	5	3	M12	213,80	241,99	254,89	267,39	295,91	310,80
25,00	184	80	5	3	M12	212,35	249,70	262,39	279,57	315,18	328,92
26,00	192	90	5	3	M12	235,19	269,61	283,32	290,52	325,53	339,74
28,00	192	90	5	3	M12	238,32	285,29	300,50	288,41	325,53	339,74
30,00	192	90	5	3	M12	274,72	320,34	336,60	343,97	389,90	406,93
32,00	229	100	6	4	M16	323,88	379,31	398,57	409,64	465,48	485,83
36,00	231	106	6	4	M16	370,86	425,34	446,92	469,20	523,72	546,58
40,00	250	125	6	4	M16	412,09	478,58	502,90	576,58	640,88	668,89
45,00	250	125	6	4	M16	555,41	636,33	670,29	735,43	809,86	845,25
50,00	268	110	6	5	M20	677,84	745,53	785,34	917,74	982,12	1.025,01
56,00	308	150	8	5	M20	713,33	778,39	821,29	1.069,44	1.125,43	1.185,59
63,00	338	180	8	5	M20	943,54	992,75	1.045,53	1.346,36	1.387,05	1.461,15

JOGOS DE FRESAS COM CORTE AO CENTRO EM ESTOJOS DE PLÁSTICO

2 Z  **DIN 327**



4 Z  **DIN 844**



REFERÊNCIA	PTF20	PTF60
Nº FRESAS	8	8
TIPO	Ref. FF02	Ref. FF60
QUALIDADE	HSSCo 8%	TiAIN
CONTEÚDO	$\frac{6}{2}$ $\frac{8}{2}$ $\frac{10}{2}$ $\frac{12}{2}$	$\frac{6}{2}$ $\frac{8}{2}$ $\frac{10}{2}$ $\frac{12}{2}$
Ø mm		
P.V.P. €	152,15	241,25

REFERÊNCIA	PTF24	PTF64
Nº FRESAS	8	8
TIPO	Ref. FF18	Ref. FF20
QUALIDADE	HSSCo 8%	TiAIN
CONTEÚDO	$\frac{6}{2}$ $\frac{8}{2}$ $\frac{10}{2}$ $\frac{12}{2}$	$\frac{6}{2}$ $\frac{8}{2}$ $\frac{10}{2}$ $\frac{12}{2}$
Ø mm		
P.V.P. €	168,46	255,58

2 Z  **DIN 327**



4 Z  **DIN 844**



REFERÊNCIA	PTF21	PTF61
Nº FRESAS	6	6
TIPO	Ref. FF02	Ref. FF60
QUALIDADE	HSSCo 8%	TiAIN
CONTEÚDO	6-8-10-12-16-20	6-8-10-12-16-20
Ø mm		
P.V.P. €	164,66	250,50

REFERÊNCIA	PTF25	PTF65
Nº FRESAS	6	6
TIPO	Ref. FF18	Ref. FF20
QUALIDADE	HSSCo 8%	TiAIN
CONTEÚDO	6-8-10-12-16-20	6-8-10-12-16-20
Ø mm		
P.V.P. €	183,88	265,21

2 Z  **DIN 327**



4 Z  **DIN 844**



REFERÊNCIA	PTF22	PTF62
Nº FRESAS	6	6
TIPO	Ref. FF02	Ref. FF60
QUALIDADE	HSSCo 8%	TiAIN
CONTEÚDO	4-5-6-8-10-12	4-5-6-8-10-12
Ø mm		
P.V.P. €	104,34	167,80

REFERÊNCIA	PTF26	PTF66
Nº FRESAS	6	6
TIPO	Ref. FF18	Ref. FF20
QUALIDADE	HSSCo 8%	TiAIN
CONTEÚDO	4-5-6-8-10-12	4-5-6-8-10-12
Ø mm		
P.V.P. €	115,54	178,15

JOGOS DE FRESAS COM CORTE AO CENTRO EM ESTOJOS METÁLICOS

2 Z

DIN
327

REFERÊNCIA	FF010787	FF020787	FT020787	FF600787
Nº FRESAS	6	6	6	6
TIPO	Ref. FF01	Ref. FF02	Ref. FT02	Ref. FF60
QUALIDADE	HSS	HSSCo 8%	TiAlSiN	TiAlN
CONTEÚDO Ø mm	4 - 5 - 6 - 8 - 10 - 12	4 - 5 - 6 - 8 - 10 - 12	4 - 5 - 6 - 8 - 10 - 12	4 - 5 - 6 - 8 - 10 - 12
P.V.P. €	96,58	127,73	148,94	191,18
REFERÊNCIA	FF010447	FF020447	FT020447	FF600447
Nº FRESAS	6	6	6	6
TIPO	Ref. FF01	Ref. FF02	Ref. FT02	Ref. FF60
QUALIDADE	HSS	HSSCo 8%	TiAlSiN	TiAlN
CONTEÚDO Ø mm	6 - 8 - 10 - 12 - 16 - 20	6 - 8 - 10 - 12 - 16 - 20	6 - 8 - 10 - 12 - 16 - 20	6 - 8 - 10 - 12 - 16 - 20
P.V.P. €	144,47	191,59	223,42	277,40

JOGOS DE FRESAS EM ESTOJOS METÁLICOS

4 Z

DIN
844

REFERÊNCIA	FF030787	FF040787	FT040787	FF540787
Nº FRESAS	6	6	6	6
TIPO	Ref. FF03	Ref. FF04	Ref. FT04	Ref. FF54
QUALIDADE	HSS	HSSCo 8%	TiAlSiN	TiAlN
CONTEÚDO Ø mm	4 - 5 - 6 - 8 - 10 - 12	4 - 5 - 6 - 8 - 10 - 12	4 - 5 - 6 - 8 - 10 - 12	4 - 5 - 6 - 8 - 10 - 12
P.V.P. €	94,99	125,28	146,78	191,17
REFERÊNCIA	FF030847	FF040847	FT040847	FF540847
Nº FRESAS	6	6	6	6
TIPO	Ref. FF03	Ref. FF04	Ref. FT04	Ref. FF54
QUALIDADE	HSS	HSSCo 8%	TiAlSiN	TiAlN
CONTEÚDO Ø mm	6 - 8 - 10 - 12 - 16 - 20	6 - 8 - 10 - 12 - 16 - 20	6 - 8 - 10 - 12 - 16 - 20	6 - 8 - 10 - 12 - 16 - 20
P.V.P. €	141,94	190,43	223,14	274,33

REFERÊNCIA	FF250847	FT250847	FF270847
Nº FRESAS	6	6	6
TIPO	Ref. FF25	Ref. FT25	Ref. FF27
QUALIDADE	HSSCo 8%	TiAlSiN	TiAlN
CONTEÚDO Ø mm	6 - 8 - 10 - 12 - 16 - 20	6 - 8 - 10 - 12 - 16 - 20	6 - 8 - 10 - 12 - 16 - 20
P.V.P. €	354,47	413,37	426,37

4 Z

DIN
844

NR

JOGOS DE FRESAS EM ESTOJOS METÁLICOS

4 Z  **DIN 844**

REFERÊNCIA	FF180787	FT180787	FF200787
Nº FRESAS	6	6	6
TIPO	Ref. FF18	Ref. FT18	Ref. FF20
QUALIDADE	HSSCo 8%	TiAlSiN	TiAlN
CONTEÚDO Ø mm	4 - 5 - 6 - 8 - 10 - 12	4 - 5 - 6 - 8 - 10 - 12	4 - 5 - 6 - 8 - 10 - 12
P.V.P. €	133,38	155,54	201,52









Ref. FF180787

REFERÊNCIA	FF180847	FT180847	FF200847
Nº FRESAS	6	6	6
TIPO	Ref. FF18	Ref. FT18	Ref. FF20
QUALIDADE	HSSCo 8%	TiAlSiN	TiAlN
CONTEÚDO Ø mm	6 - 8 - 10 - 12 - 16 - 20	6 - 8 - 10 - 12 - 16 - 20	6 - 8 - 10 - 12 - 16 - 20
P.V.P. €	208,51	243,17	289,32



Ref. FF180847

EXPOSITOR DE METACRILATO		Ref. MF-01				Ref. MF-01			
Conteúdo: 163 Fresas									
Ref. FF13	1 Z	HSSCo	Al	SÉRIE CURTA	Ø	5 x 8	Cabo	6 x 8	Cabo
					Quant.	5		5	
Ref. FF14	1 Z	HSSCo	Al	SÉRIE LONGA	Ø	5 x 8	Cabo	6 x 8	Cabo
					Quant.	5		5	
Ref. FF02	2 Z		HSSCo	DIN 327N		Ø	2 3 4 5 6 7 8 9 10 12 14 16		
						Quant.	5 5 5 5 5 5 5 5 5 5 5 5 3		
Ref. FF18	4 Z		HSSCo	DIN 844N		Ø	2 3 4 5 6 7 8 9 10 12 14 16		
						Quant.	5 5 5 5 5 5 5 5 5 5 5 5 3		
Ref. FF25	4 Z		HSSCo	DIN 844N		Ø	6 7 8 9 10 11 12 14 16		
						Quant.	3 3 3 3 3 3 3 3 3		



Dimensões: largo 245 x fundo 210 x altura 350 mm
 NOTA: Composições especiais sob demanda.

P.V.P. **4.311,24 €**

PARÂMETROS DE CORTE ORIENTATIVOS FRESAS HSSCO 8%

		DIÂMETRO Ø (mm)														
		2	4	6	8	10	12	18	22	26	30	32	36	40		
AÇO BAIXA LIGA 70 kg/mm ²	V/C 39	RPM	6207	3104	2069	1552	1241	1035	690	564	477	414	388	345	310	
	AVANÇO (mm/min)	Nº cortes	2	50	56	74	84	82	81	80	81	76	68	68	62	60
		3	74	84	112	126	123	121	120	122	115	102	102	93	89	
		4	99	112	149	168	164	161	160	163	153	136	137	124	119	
AÇO TRATADO 120 kg/mm ²	V/C 20	RPM	3183	1592	1061	796	637	531	354	289	245	212	199	177	159	
	AVANÇO (mm/min)	Nº cortes	2	25	29	38	43	42	41	41	42	39	35	35	32	31
		3	38	43	57	64	63	62	62	63	59	52	53	48	46	
		4	51	57	76	86	84	83	82	83	78	70	70	64	61	
INOXIDÁVEL	V/C 15	RPM	2387	1194	796	597	477	398	265	217	184	159	149	133	119	
	AVANÇO (mm/min)	Nº cortes	2	19	21	29	32	32	31	31	31	29	26	26	24	23
		3	29	32	43	48	47	47	46	47	44	39	39	36	34	
		4	38	43	57	64	63	62	62	63	59	52	53	48	46	
ALUMÍNIO	V/C 230	RPM	36606	18303	12202	9151	7321	6101	4067	3328	2816	2440	2288	2034	1830	
	AVANÇO (mm/min)	Nº cortes	2	293	329	439	494	483	476	472	479	451	400	403	366	351
		3	439	494	659	741	725	714	708	719	676	600	604	549	527	
		4	586	659	879	988	966	952	944	958	901	800	805	732	703	
TITÂNIO	V/C 12	RPM	1910	955	637	477	382	318	212	174	147	127	119	106	95	
	AVANÇO (mm/min)	Nº cortes	2	15	17	23	26	25	25	25	25	24	21	21	19	18
		3	23	26	34	39	38	37	37	37	38	35	31	32	29	28
		4	31	34	46	52	50	50	49	50	47	42	42	38	37	

* Para as fresas revestidas multiplique os parâmetros na tabela por 1,3 e para as fresas ASP 60 multiplique por 1,8.

* V/C: Velocidade de corte (m/min).

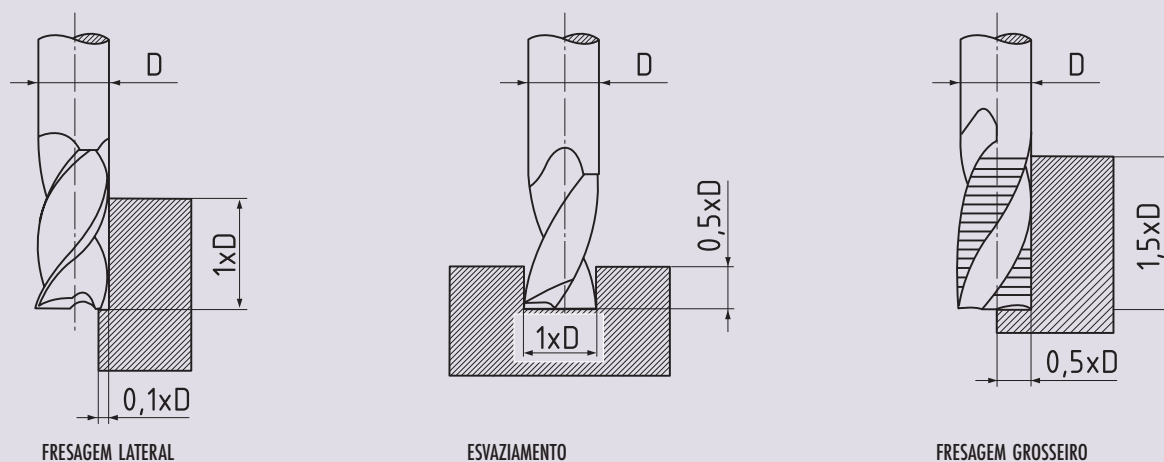
PROFUNDIDADE DE PASSADA EM FUNÇÃO DA OPERAÇÃO A REALIZAR

BLUE-MASTER®
by *celesa*



FRESAS DE
METAL DURO

FRESAS FRONTAIS DE METAL DURO INTEGRAL PARA APLICAÇÕES GERAIS SÉRIE CURTA

FRESAS

Rosa

USO GERAL

MD

30° N

CILÍNDRICO

2Z

3Z

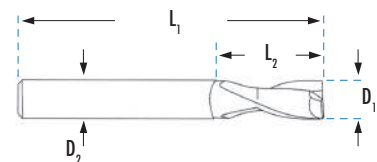

SÉRIE CURTA

MATERIAL				FMD2		FMD2TL		FMD63		FMD63TL	
ACABAMENTO				MD		MD		MD		MD	
QUALIDADE				BRILHANTE		TiAlN		BRILHANTE		TiAlN	
				★★		★★★		★★		★★★	
				2Z		2Z		3Z		3Z	
D ₁ mm	L ₁ mm	L ₂ mm	D ₂ mm	€	€	€	€	€	€	€	€
1,00	38	3	3	FMD20100	18,26	FMD20100TIALN	24,21	FMD630100	18,26	FMD630100TIALN	24,21
1,00	50	3	4	FMD20100X50	19,56	FMD20100X50TIALN	26,71	FMD630100X50	19,56	FMD630100X50TIALN	26,71
1,50	38	4	3	FMD20150	18,26	FMD20150TIALN	24,21	FMD630150	18,26	FMD630150TIALN	24,21
1,50	50	4	4	FMD20150X50	19,56	FMD20150X50TIALN	26,71	FMD630150X50	19,56	FMD630150X50TIALN	26,71
2,00	38	6	3	FMD20200	18,26	FMD20200TIALN	24,21	FMD630200	18,26	FMD630200TIALN	24,21
2,00	50	6	4	FMD20200X50	19,56	FMD20200X50TIALN	26,71	FMD630200X50	19,56	FMD630200X50TIALN	26,71
2,50	38	8	3	FMD20250	18,26	FMD20250TIALN	24,21	FMD630250	18,26	FMD630250TIALN	24,21
2,50	50	8	4	FMD20250X50	19,56	FMD20250X50TIALN	26,71	FMD630250X50	19,56	FMD630250X50TIALN	26,71
3,00	38	8	3	FMD20300	17,52	FMD20300TIALN	23,47	FMD630300	17,52	FMD630300TIALN	23,47
3,00	50	8	4	FMD20300X5004	19,26	FMD20300X5004TIALN	27,61	FMD630300X5004	19,26	FMD630300X5004TIALN	27,61
3,00	50	8	6	FMD20300X5006	20,68	FMD20300X5006TIALN	28,86	FMD630300X5006	20,68	FMD630300X5006TIALN	28,86
3,50	50	11	4	FMD20350	20,48	FMD20350TIALN	26,43	FMD630350	20,48	FMD630350TIALN	26,43
4,00	50	11	4	FMD20400	17,41	FMD20400TIALN	23,36	FMD630400	17,41	FMD630400TIALN	23,36
4,00	50	11	6	FMD20400X5006	21,21	FMD20400X5006TIALN	28,96	FMD630400X5006	21,21	FMD630400X5006TIALN	28,96
4,50	50	11	6	FMD20450	22,43	FMD20450TIALN	28,38	FMD630450	22,43	FMD630450TIALN	28,38
5,00	50	13	5	FMD20500	19,77	FMD20500TIALN	25,72	FMD630500	19,77	FMD630500TIALN	25,72
5,00	50	13	6	FMD20500X5006	21,96	FMD20500X5006TIALN	29,15	FMD630500X5006	21,96	FMD630500X5006TIALN	29,15
5,50	50	16	6	FMD20550	21,63	FMD20550TIALN	29,18	FMD630550	21,63	FMD630550TIALN	29,18
6,00	50	16	6	FMD20600	21,63	FMD20600TIALN	27,58	FMD630600	21,63	FMD630600TIALN	27,58
6,00	58	22	6	FMD20600X58	23,25	FMD20600X58TIALN	29,36	FMD630600X58	23,25	FMD630600X58TIALN	29,36
6,35	60	19	8	FMD20635	25,25	FMD20635TIALN	31,25	FMD630635	25,25	FMD630635TIALN	31,25
6,50	60	19	8	FMD20650	28,36	FMD20650TIALN	35,65	FMD630650	28,36	FMD630650TIALN	35,65
7,00	60	19	8	FMD20700	35,39	FMD20700TIALN	42,54	FMD630700	35,39	FMD630700TIALN	42,54
7,50	60	19	8	FMD20750	35,39	FMD20750TIALN	42,54	FMD630750	35,39	FMD630750TIALN	42,54
8,00	60	19	8	FMD20800	32,16	FMD20800TIALN	39,30	FMD630800	32,16	FMD630800TIALN	39,30
8,50	72	22	10	FMD20850	37,37	FMD20850TIALN	44,36	FMD630850	37,37	FMD630850TIALN	44,36
9,00	72	22	10	FMD20900	38,63	FMD20900TIALN	45,36	FMD630900	38,63	FMD630900TIALN	45,36
9,50	72	22	10	FMD20950	51,11	FMD20950TIALN	61,21	FMD630950	51,11	FMD630950TIALN	61,21
10,00	72	22	10	FMD21000	48,30	FMD21000TIALN	56,63	FMD631000	48,30	FMD631000TIALN	56,63
10,00	80	32	10	FMD21000X80	52,36	FMD21000X80TIALN	60,12	FMD631000X80	52,36	FMD631000X80TIALN	60,12
10,50	75	26	12	FMD21050	52,36	FMD21050TIALN	61,11	FMD631050	52,36	FMD631050TIALN	61,11
11,00	75	26	12	FMD21100	70,67	FMD21100TIALN	80,19	FMD631100	70,67	FMD631100TIALN	80,19
12,00	75	26	12	FMD21200	61,59	FMD21200TIALN	71,10	FMD631200	61,59	FMD631200TIALN	71,10
12,50	84	30	14	FMD21250	62,63	FMD21250TIALN	71,11	FMD631250	62,63	FMD631250TIALN	71,11
13,00	84	30	14	FMD21300	63,36	FMD21300TIALN	71,25	FMD631300	63,36	FMD631300TIALN	71,25
14,00	84	30	14	FMD21400	94,63	FMD21400TIALN	106,54	FMD631400	94,63	FMD631400TIALN	106,54
14,00	100	50	14	FMD21400X100	105,36	FMD21400X100TIALN	118,36	FMD631400X100	105,36	FMD631400X100TIALN	118,36
15,00	92	32	16	FMD21500	108,25	FMD21500TIALN	121,25	FMD631500	108,25	FMD631500TIALN	121,25
16,00	92	32	16	FMD21600	122,26	FMD21600TIALN	135,36	FMD631600	122,26	FMD631600TIALN	135,36
16,00	100	50	16	FMD21600X100	131,36	FMD21600X100TIALN	145,36	FMD631600X100	131,36	FMD631600X100TIALN	145,36
17,00	100	38	18	FMD21700	124,36	FMD21700TIALN	138,96	FMD631700	124,36	FMD631700TIALN	138,96
18,00	100	38	18	FMD21800	179,14	FMD21800TIALN	197,00	FMD631800	179,14	FMD631800TIALN	197,00
18,00	100	50	18	FMD21800X10050	196,36	FMD21800X10050TIALN	216,36	FMD631800X10050	196,36	FMD631800X10050TIALN	216,36
19,00	100	38	20	FMD21900	201,36	FMD21900TIALN	221,36	FMD631900	201,36	FMD631900TIALN	221,36
20,00	100	38	20	FMD22000	203,76	FMD22000TIALN	226,38	FMD632000	203,76	FMD632000TIALN	226,38
20,00	100	50	20	FMD22000X10050	215,36	FMD22000X10050TIALN	238,36	FMD632000X10050	215,36	FMD632000X10050TIALN	238,36
22,00	100	38	22	FMD22200	289,36	FMD22200TIALN	325,36	FMD632200	289,36	FMD632200TIALN	325,36
25,00	100	45	25	FMD22500	353,57	FMD22500TIALN	388,10	FMD632500	353,57	FMD632500TIALN	388,10
25,00	110	55	25	FMD22500X110	389,36	FMD22500X110TIALN	436,36	FMD632500X110	389,36	FMD632500X110TIALN	436,36



FMD2 FMD63



44
HRC

FRESAS FRONTAIS DE METAL DURO INTEGRAL PARA APLICAÇÕES GERAIS SÉRIE CURTA

USO
GERAL

MD



30°

N



CILÍNDRICO

4 Z



TOL D1
+0 -0,05

TOL D2
h6

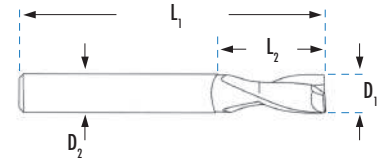

SÉRIE CURTA

MATERIAL				FMD48		FMD48TL	
ACABAMENTO				MD		MD	
QUALIDADE				BRILHANTE		TiAlN	
				★★		★★★	
				4Z		4Z	
D1 mm	L1 mm	L2 mm	D2 mm		€		€
1,00	38	3	3	FMD480100	18,26	FMD480100TIALN	24,21
1,00	50	3	4	FMD480100X50	19,56	FMD480100X50TIALN	26,71
1,50	38	4	3	FMD480150	18,26	FMD480150TIALN	24,21
1,50	50	4	4	FMD480150X50	19,56	FMD480150X50TIALN	26,71
2,00	38	6	3	FMD480200	18,26	FMD480200TIALN	24,21
2,00	50	6	4	FMD480200X50	19,56	FMD480200X50TIALN	26,71
2,50	38	8	3	FMD480250	18,26	FMD480250TIALN	24,21
2,50	50	8	4	FMD480250X50	19,56	FMD480250X50TIALN	26,71
3,00	38	8	3	FMD480300	17,52	FMD480300TIALN	23,47
3,00	50	8	4	FMD480300X5004	19,26	FMD480300X5004TIALN	27,61
3,00	50	8	6	FMD480300X5006	20,68	FMD480300X5006TIALN	28,86
3,50	50	11	4	FMD480350	20,48	FMD480350TIALN	26,43
4,00	50	11	4	FMD480400	17,41	FMD480400TIALN	23,36
4,00	50	11	6	FMD480400X5006	21,21	FMD480400X5006TIALN	28,96
4,50	50	11	6	FMD480450	22,43	FMD480450TIALN	28,38
5,00	50	13	5	FMD480500	19,77	FMD480500TIALN	25,72
5,00	50	13	6	FMD480500X5006	21,96	FMD480500X5006TIALN	29,15
5,50	50	16	6	FMD480550	21,63	FMD480550TIALN	29,18
6,00	50	16	6	FMD480600	21,63	FMD480600TIALN	27,58
6,00	58	22	6	FMD480600X58	23,25	FMD480600X58TIALN	29,36
6,35	60	19	8	FMD480635	25,25	FMD480635TIALN	31,25
6,50	60	19	8	FMD480650	28,36	FMD480650TIALN	35,65
7,00	60	19	8	FMD480700	35,39	FMD480700TIALN	42,54
7,50	60	19	8	FMD480750	35,39	FMD480750TIALN	42,54
8,00	60	19	8	FMD480800	32,16	FMD480800TIALN	39,30
8,50	72	22	10	FMD480850	37,37	FMD480850TIALN	44,36
9,00	72	22	10	FMD480900	38,63	FMD480900TIALN	45,36
9,50	72	22	10	FMD480950	51,11	FMD480950TIALN	61,21
10,00	72	22	10	FMD481000	48,30	FMD481000TIALN	56,63
10,00	80	32	10	FMD481000X80	52,36	FMD481000X80TIALN	60,12
10,50	75	26	12	FMD481050	52,36	FMD481050TIALN	61,11
11,00	75	26	12	FMD481100	70,67	FMD481100TIALN	80,19
12,00	75	26	12	FMD481200	61,59	FMD481200TIALN	71,10
12,50	84	30	14	FMD481250	62,63	FMD481250TIALN	71,11
13,00	84	30	14	FMD481300	63,36	FMD481300TIALN	71,25
14,00	84	30	14	FMD481400	94,63	FMD481400TIALN	106,54
14,00	100	50	14	FMD481400X100	105,36	FMD481400X100TIALN	118,36
15,00	92	32	16	FMD481500	108,25	FMD481500TIALN	121,25
16,00	92	32	16	FMD481600	122,26	FMD481600TIALN	135,36
16,00	100	50	16	FMD481600X100	131,36	FMD481600X100TIALN	145,36
17,00	100	38	18	FMD481700	124,36	FMD481700TIALN	138,96
18,00	100	38	18	FMD481800	179,14	FMD481800TIALN	197,00
18,00	100	50	18	FMD481800X10050	196,36	FMD481800X10050TIALN	216,36
19,00	100	38	20	FMD481900	201,36	FMD481900TIALN	221,36
20,00	100	38	20	FMD482000	203,76	FMD482000TIALN	226,38
20,00	100	50	20	FMD482000X10050	215,36	FMD482000X10050TIALN	238,36
22,00	100	38	22	FMD482200	289,36	FMD482200TIALN	325,36
25,00	100	45	25	FMD482500	353,57	FMD482500TIALN	388,10
25,00	110	55	25	FMD482500X110	389,36	FMD482500X110TIALN	436,36



FMD48 FMD48TL



44
HRC

FRESAS FRONTAIS DE METAL DURO INTEGRAL PARA APLICAÇÕES GERAIS SÉRIE LONGA
**USO
GERAL**
MD

CILÍNDRICO
2Z

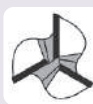
3Z

4Z

SÉRIE LONGA

MATERIAL				FMD54		FMD54TL		FMD73		FMD73TL	
ACABAMENTO				MD	MD	MD	MD	MD	MD	MD	
QUALIDADE				BRILHANTE	BRILHANTE	TiAIN	BRILHANTE	BRILHANTE	TiAIN	TiAIN	
				★★	★★	★★★	★★	★★	★★	★★	
				2Z	2Z	2Z	3Z	3Z	3Z	3Z	
D1 mm	L1 mm	L2 mm	D2 mm	€	€	€	€	€	€	€	
1,00	60	5	3	FMD540100	18,41	FMD540100TIALN	25,55	FMD730100	18,41	FMD730100TIALN	25,55
2,00	60	10	3	FMD540200	18,89	FMD540200TIALN	26,03	FMD730200	18,89	FMD730200TIALN	26,03
3,00	60	15	3	FMD540300	19,40	FMD540300TIALN	26,54	FMD730300	19,40	FMD730300TIALN	26,54
4,00	80	20	4	FMD540400	20,45	FMD540400TIALN	27,58	FMD730400	20,45	FMD730400TIALN	27,58
5,00	80	25	5	FMD540500	25,45	FMD540500TIALN	32,59	FMD730500	25,45	FMD730500TIALN	32,59
6,00	80	25	6	FMD540600	35,89	FMD540600TIALN	43,02	FMD730600	35,89	FMD730600TIALN	43,02
7,00	90	35	8	FMD540700	37,85	FMD540700TIALN	47,69	FMD730700	37,85	FMD730700TIALN	47,69
8,00	90	35	8	FMD540800	40,86	FMD540800TIALN	50,39	FMD730800	40,86	FMD730800TIALN	50,39
9,00	100	45	10	FMD540900	53,36	FMD540900TIALN	64,25	FMD730900	53,36	FMD730900TIALN	64,25
10,00	100	45	10	FMD541000	57,74	FMD541000TIALN	67,27	FMD731000	57,74	FMD731000TIALN	67,27
12,00	100	50	12	FMD541200	78,82	FMD541200TIALN	90,73	FMD731200	78,82	FMD731200TIALN	90,73
14,00	150	65	14	FMD541400	129,70	FMD541400TIALN	145,17	FMD731400	129,70	FMD731400TIALN	145,17
16,00	150	65	16	FMD541600	142,10	FMD541600TIALN	157,57	FMD731600	142,10	FMD731600TIALN	157,57
16,00	150	90	16	FMD541600X15090	156,30	FMD541600X15090TIALN	173,33	FMD731600X15090	156,30	FMD731600X15090TIALN	173,33
20,00	150	70	20	FMD542000	252,06	FMD542000TIALN	275,88	FMD732000	252,06	FMD732000TIALN	275,88
25,00	150	75	25	FMD542500	496,36	FMD542500TIALN	523,31	FMD732500	496,36	FMD732500TIALN	523,31

FMD54 FMD73

**44
HRc**
SÉRIE LONGA

MATERIAL				FMD58		FMD58TL	
ACABAMENTO				MD	MD	MD	MD
QUALIDADE				BRILHANTE	BRILHANTE	TiAIN	TiAIN
				★★	★★	★★★	★★★
				4Z	4Z	4Z	4Z
D1 mm	L1 mm	L2 mm	D2 mm	€	€	€	€
1,00	60	5	3	FMD580100	18,41	FMD580100TIALN	25,55
2,00	60	10	3	FMD580200	18,89	FMD580200TIALN	26,03
3,00	60	15	3	FMD580300	19,40	FMD580300TIALN	26,54
4,00	80	20	4	FMD580400	20,45	FMD580400TIALN	27,58
5,00	80	25	5	FMD580500	25,45	FMD580500TIALN	32,59
6,00	80	25	6	FMD580600	35,89	FMD580600TIALN	43,02
7,00	90	35	8	FMD580700	37,85	FMD580700TIALN	47,69
8,00	90	35	8	FMD580800	40,86	FMD580800TIALN	50,39
9,00	100	45	10	FMD580900	53,36	FMD580900TIALN	64,25
10,00	100	45	10	FMD581000	57,74	FMD581000TIALN	67,27
12,00	100	50	12	FMD581200	78,82	FMD581200TIALN	90,73
14,00	150	65	14	FMD581400	129,70	FMD581400TIALN	145,17
16,00	150	65	16	FMD581600	142,10	FMD581600TIALN	157,57
16,00	150	90	16	FMD581600X15090	156,30	FMD581600X15090TIALN	173,33
20,00	150	70	20	FMD582000	252,06	FMD582000TIALN	275,88
25,00	150	75	25	FMD582500	496,36	FMD582500TIALN	523,31

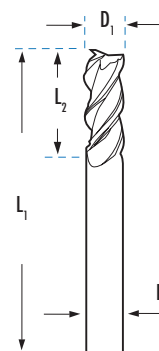
FMD58 FMD58TL

**44
HRc**

FRESAS FRONTAIS DE METAL DURO INTEGRAL PARA APLICAÇÕES GERAIS SÉRIE EXTRA-LONGA

USO GERAL

MD



30°
N



CILÍNDRICO

2Z



4Z

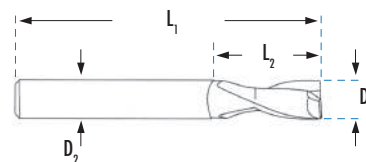

SÉRIE EXTRA-LONGA

MATERIAL				FMD53		FMD53TL		FMD56		FMD56TL	
ACABAMENTO				MD	MD	MD	MD	MD	MD	MD	
QUALIDADE				BRILHANTE	BRILHANTE	TiAlN	BRILHANTE	TiAlN	BRILHANTE	TiAlN	
				★★	★★★	★★★	★★	★★★	★★★	★★★	
				2Z	2Z	2Z	4Z	4Z	4Z	4Z	
Ø mm	L1 mm	L2 mm	D2 mm	€	€	€	€	€	€		
3,00	75	25	3	FMD530300	41,71	FMD530300TIALN	53,62	FMD560300	43,16	FMD560300TIALN	55,07
3,00	100	25	3	FMD530300X100	44,46	FMD530300X100TIALN	56,54	FMD560300X100	45,66	FMD560300X100TIALN	57,36
4,00	100	25	4	FMD530400	45,32	FMD530400TIALN	57,23	FMD560400	46,74	FMD560400TIALN	58,65
5,00	100	25	5	FMD530500	51,22	FMD530500TIALN	63,13	FMD560500	53,82	FMD560500TIALN	65,73
6,00	100	25	6	FMD530600X10025	77,25	FMD530600X10025TIALN	96,96	FMD560600X10025	79,57	FMD560600X10025TIALN	99,87
6,00	100	40	6	FMD530600X10040	78,85	FMD530600X10040TIALN	98,11	FMD560600X10040	81,22	FMD560600X10040TIALN	101,05
6,00	150	25	6	FMD530600X15025	80,80	FMD530600X15025TIALN	99,36	FMD560600X15025	83,22	FMD560600X15025TIALN	102,34
6,00	150	40	6	FMD530600X15040	83,36	FMD530600X15040TIALN	102,25	FMD560600X15040	85,86	FMD560600X15040TIALN	105,32
6,00	150	75	6	FMD530600	85,49	FMD530600TIALN	104,54	FMD560600	90,42	FMD560600TIALN	108,73
8,00	100	45	8	FMD530800X10045	106,33	FMD530800X10045TIALN	132,36	FMD560800X10045	109,52	FMD560800X10045TIALN	136,33
8,00	150	25	8	FMD530800X15025	111,11	FMD530800X15025TIALN	135,37	FMD560800X15025	114,44	FMD560800X15025TIALN	139,43
8,00	150	45	8	FMD530800X15045	114,45	FMD530800X15045TIALN	137,89	FMD560800X15045	117,88	FMD560800X15045TIALN	142,03
8,00	150	75	8	FMD530800	117,71	FMD530800TIALN	140,34	FMD560800	124,50	FMD560800TIALN	146,25
10,00	150	38	10	FMD531000X15038	137,36	FMD531000X15038TIALN	169,69	FMD561000X15038	141,48	FMD561000X15038TIALN	174,78
10,00	150	50	10	FMD531000X15050	141,41	FMD531000X15050TIALN	172,25	FMD561000X15050	145,65	FMD561000X15050TIALN	177,42
10,00	150	65	10	FMD531000X15065	145,36	FMD531000X15065TIALN	175,75	FMD561000X15065	149,72	FMD561000X15065TIALN	181,02
10,00	150	75	10	FMD531000	149,10	FMD531000TIALN	178,87	FMD561000	164,01	FMD561000TIALN	193,77
12,00	150	38	12	FMD531200X15038	199,96	FMD531200X15038TIALN	241,14	FMD561200X15038	205,96	FMD561200X15038TIALN	248,37
12,00	150	50	12	FMD531200X15050	205,36	FMD531200X15050TIALN	247,47	FMD561200X15050	211,52	FMD561200X15050TIALN	254,89
12,00	150	75	12	FMD531200	218,16	FMD531200TIALN	256,26	FMD561200	239,97	FMD561200TIALN	278,08
12,00	200	38	12	FMD531200X20038	231,25	FMD531200X20038TIALN	272,36	FMD561200X20038	258,36	FMD561200X20038TIALN	281,11
14,00	150	75	14	FMD531400	301,59	FMD531400TIALN	348,03	FMD561400	331,75	FMD561400TIALN	378,19
16,00	200	75	16	FMD531600	409,75	FMD531600TIALN	463,33	FMD561600	450,73	FMD561600TIALN	504,31
20,00	200	75	20	FMD532000	639,35	FMD532000TIALN	710,79	FMD562000	639,35	FMD562000TIALN	710,79



FMD53 FMD56



44
HRc

Fresas
Rosa

FRESAS FRONTAIS ESFÉRICAS DE METAL DURO INTEGRAL PARA APLICAÇÕES GERAIS SÉRIE CURTA E LONGA

USO
GERAL

MD

30°
N

CILÍNDRICO

2Z



4Z

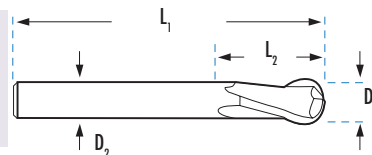

SÉRIE CURTA

MATERIAL				FMD92		FMD92TL		FMD51		FMD51TL	
ACABAMENTO				MD	MD	MD	MD	MD	MD	MD	
QUALIDADE				BRILHANTE	TiAlN	BRILHANTE	TiAlN	BRILHANTE	TiAlN	TiAlN	
				★★	★★★	★★	★★★	★★	★★★	★★★	
				2Z	2Z	4Z	4Z	4Z	4Z	4Z	
D1 mm	L1 mm	L2 mm	D2 mm	€	€	€	€	€	€	€	
1,00	38	2	3	FMD920100	21,91	FMD920100TIALN	27,86	FMD510100		FMD510100TIALN	
1,00	50	2	4	FMD920100X50	26,56	FMD920100X50TIALN	34,12	FMD510100X50		FMD510100X50TIALN	
1,50	38	3	3	FMD920150	21,91	FMD920150TIALN	27,86	FMD510150		FMD510150TIALN	
1,50	50	3	4	FMD920150X50	26,56	FMD920150X50TIALN	34,12	FMD510150X50		FMD510150X50TIALN	
2,00	38	4	3	FMD920200	21,91	FMD920200TIALN	27,86	FMD510200		FMD510200TIALN	
2,00	50	4	4	FMD920200X50	26,56	FMD920200X50TIALN	34,12	FMD510200X50		FMD510200X50TIALN	
2,50	38	5	3	FMD920250	21,91	FMD920250TIALN	27,86	FMD510250X50		FMD510250X50TIALN	
3,00	38	6	3	FMD920300	21,91	FMD920300TIALN	27,86	FMD510300	24,11	FMD510300TIALN	30,65
3,00	50	6	4	FMD920300X50	26,56	FMD920300X50TIALN	34,12	FMD510300X50		FMD510300X50TIALN	
4,00	50	8	4	FMD920400	24,97	FMD920400TIALN	30,92	FMD510400	27,47	FMD510400TIALN	34,01
5,00	50	10	5	FMD920500	26,42	FMD920500TIALN	32,38	FMD510500	29,06	FMD510500TIALN	35,61
6,00	50	12	6	FMD920600	31,09	FMD920600TIALN	37,04	FMD510600	34,21	FMD510600TIALN	40,75
7,00	60	15	8	FMD920700	37,85*	FMD920700TIALN	44,25	FMD510700	40,55	FMD510700TIALN	47,96
8,00	60	15	8	FMD920800	38,38	FMD920800TIALN	45,52	FMD510800	47,99	FMD510800TIALN	56,91
10,00	75	20	10	FMD921000	57,67	FMD921000TIALN	66,00	FMD511000	72,07	FMD511000TIALN	82,50
12,00	75	20	12	FMD921200	71,65	FMD921200TIALN	81,17	FMD511200	89,55	FMD511200TIALN	101,46
14,00	90	25	14	FMD921400	106,06	FMD921400TIALN	117,97	FMD511400	132,58	FMD511400TIALN	147,46
16,00	100	25	16	FMD921600	134,19	FMD921600TIALN	147,28	FMD511600	167,74	FMD511600TIALN	184,11
18,00	100	30	18	FMD921800	199,51	FMD921800TIALN	217,37	FMD511800	249,39	FMD511800TIALN	271,72
20,00	100	30	20	FMD922000	206,84	FMD922000TIALN	229,46	FMD512000	258,53	FMD512000TIALN	286,82

TOL D1
+0 -0,05TOL D2
h6

FMD92 FMD51



*Até o fim das existências.

SÉRIE LONGA

MATERIAL				FMD57		FMD57TL	
ACABAMENTO				MD	MD	MD	MD
QUALIDADE				BRILHANTE	TiAlN	BRILHANTE	TiAlN
				★★	★★★	★★	★★★
				2Z	2Z	2Z	2Z
D1 mm	L1 mm	L2 mm	D2 mm	€	€	€	€
1,00	60	2	3	FMD570100	33,03	FMD570100TIALN	40,18
1,50	60	3	3	FMD570150	33,03	FMD570150TIALN	40,18
2,00	60	3	3	FMD570200	33,03	FMD570200TIALN	40,18
2,50	60	3	3	FMD570250	33,03	FMD570250TIALN	40,18
3,00	60	4	3	FMD570300	33,03	FMD570300TIALN	40,18
4,00	80	5	4	FMD570400	38,34	FMD570400TIALN	45,49
5,00	80	6	5	FMD570500	45,35	FMD570500TIALN	52,50
6,00	80	8	6	FMD570600	53,01	FMD570600TIALN	60,14
8,00	100	12	8	FMD570800	69,96	FMD570800TIALN	79,49
10,00	100	15	10	FMD571000	86,44	FMD571000TIALN	97,16
12,00	100	15	12	FMD571200	149,80	FMD571200TIALN	161,71
14,00	150	20	14	FMD571400	187,83	FMD571400TIALN	203,32
16,00	150	20	16	FMD571600	237,24	FMD571600TIALN	252,72
20,00	150	25	20	FMD572000	489,69	FMD572000TIALN	513,50



FMD57 FMD57TL

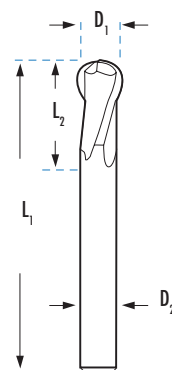

FRESAS FRONTAIS ESFÉRICAS DE METAL DURO INTEGRAL PARA APLICAÇÕES GERAIS SÉRIE EXTRA-LONGA

USO GERAL **MD** **30° N** **CILÍNDRICO** **2Z**

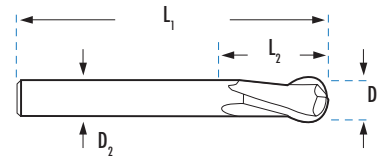

SÉRIE EXTRA-LONGA

MATERIAL				FMD55		FMD55TL	
ACABAMENTO				MD		MD	
QUALIDADE				BRILHANTE		TiAlN	
				★★		★★★	
				2Z		2Z	
D1 mm	L1 mm	L2 mm	D2 mm	€	€	€	€
3,00	75	6	3	FMD550300	39,59	FMD550300TIALN	51,50
3,00	100	6	3	FMD550300X100	42,42	FMD550300X100TIALN	55,36
4,00	100	6	4	FMD550400	45,67	FMD550400TIALN	57,57
5,00	100	6	5	FMD550500	55,19	FMD550500TIALN	67,10
6,00	100	15	6	FMD550600	69,36	FMD550600TIALN	81,27
6,00	150	15	6	FMD550600X150	81,81	FMD550600X150TIALN	96,31
6,00	200	30	6	FMD550600X200	96,36	FMD550600X200TIALN	109,12
8,00	150	25	8	FMD550800	93,17	FMD550800TIALN	111,03
8,00	200	50	8	FMD550800X200	112,12	FMD550800X200TIALN	132,11
10,00	150	25	10	FMD551000	131,27	FMD551000TIALN	149,13
10,00	200	50	10	FMD551000X200	149,99	FMD551000X200TIALN	171,71
12,00	150	25	12	FMD551200	208,78	FMD551200TIALN	242,11
12,00	200	25	12	FMD551200X200	256,36	FMD551200X200TIALN	294,22
14,00	200	50	14	FMD551400	256,40	FMD551400TIALN	294,51
16,00	200	50	16	FMD551600	344,51	FMD551600TIALN	386,18



FMD55 FMD55TL



CONDIÇÕES DE CORTE ORIENTATIVAS

		Ø2	Ø3	Ø4	Ø5	Ø6	Ø8	Ø10	Ø12	Ø14
44 HRc	RPM	4000	2600	2000	1600	1300	1000	800	660	570
	AVANÇO (mm/min)	50	55	55	55	55	55	55	55	55
INOX Ti	RPM	8000	5300	4000	3200	2600	2000	1600	1300	1100
	AVANÇO (mm/min)	55	55	55	55	60	60	60	60	60
Al	RPM	16000	11000	8000	6400	5300	4000	3200	2600	2300
	AVANÇO (mm/min)	290	290	290	290	290	290	290	290	300

* Para obter os parametros de corte recomendados para Fresas frontais com revestimento TiAlN, multiplicar os valores do requadro por 1,3.

FRESAS FRONTAIS DE METAL DURO INTEGRAL ALTO RENDIMENTO Y PRODUÇÃO

FRESAS

Rosa

USO GERAL

MD



2Z



3Z



4Z



EXCELENTE DESEMPENHO NA MAQUINAGEM.

Micro Grão MD

SÉRIE CURTA

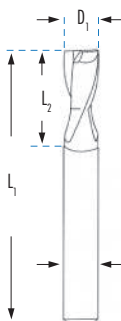

TOL D1
+0 -0,05

TOL D2
h6

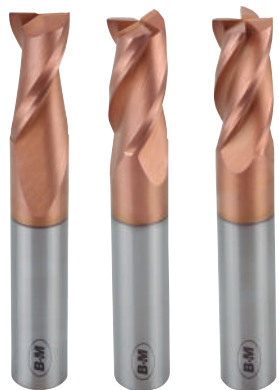

HÉLICE VARIÁVEL



FMT2 FMT63 FMT48



MATERIAL MD MD MD

ACABAMENTO TiAlSiN TiAlSiN TiAlSiN

QUALIDADE Premium Quality Premium Quality Premium Quality

2Z 3Z 4Z

D1 mm	L1 mm	L2 mm	D2 mm	€	€	€
1,00	38	3	3	45,85	45,85	45,85
1,50	38	4	3	44,77	44,77	44,77
2,00	38	6	3	35,63	35,63	35,63
2,50	38	8	3	34,82	34,82	34,82
3,00	38	8	3	29,99	29,99	29,99
3,50	50	11	4	36,81	36,81	36,81
4,00	50	11	4	34,20	34,20	34,20
4,50	50	13	5	43,74	43,74	43,74
5,00	50	13	5	43,21	43,21	43,21
6,00	50	16	6	48,71	48,71	48,71
7,00	60	16	8	67,94	67,94	67,94
8,00	60	19	8	57,66	57,66	57,66
9,00	72	19	10	82,67	82,67	82,67
10,00	72	22	10	91,92	91,92	91,92
11,00	75	26	12	122,27	122,27	122,27
12,00	75	26	12	113,69	113,69	113,69
14,00	84	30	14	169,00	169,00	169,00
16,00	92	32	16	218,92	218,92	218,92
18,00	100	38	18	304,21	304,21	304,21
20,00	100	38	20	346,83	346,83	346,83
25,00	100	38	25	569,30	569,30	569,30

FMT81



MATERIAL MD

ACABAMENTO TiAlSiN

QUALIDADE Premium Quality

4Z

D1 mm	L1 mm	L2 mm	D2 mm	€
1,00	38	3	3	
1,50	38	5	3	
2,00	38	6	3	
2,50	38	7	3	
3,00	38	12	3	
3,50	50	12	4	
4,00	50	14	4	
4,50	50	14	5	
5,00	50	16	5	47,54
6,00	63	19	6	53,59
7,00	63	19	8	
8,00	63	19	8	63,42
9,00	70	22	10	
10,00	70	22	10	101,10
11,00	75	25	11	
12,00	75	25	12	125,05
14,00	88	30	14	185,89
16,00	88	32	16	240,81
18,00	100	36	18	334,62
20,00	100	36	20	381,51
25,00	100	38	25	

FMT92



MATERIAL MD

ACABAMENTO TiAlSiN

QUALIDADE Premium Quality

2Z

D1 mm	L1 mm	L2 mm	D2 mm	€
1,00	38	2	3	
1,50	38	3	3	
2,00	38	4	3	
2,50	38	5	3	
3,00	38	6	3	39,59
4,00	50	8	4	43,92
5,00	50	10	5	54,29
6,00	50	12	6	62,11
8,00	60	15	8	76,36
10,00	75	20	10	110,69
12,00	75	20	12	136,13
14,00	90	25	14	197,84
16,00	100	25	16	247,01
18,00	100	30	18	364,56
20,00	100	30	20	384,81

* FMT81: fresa de 4 navalhas, corte ao centro, hélice variável com revestimento TiAlSiN. O seu ângulo de hélice minimiza as vibrações e junto com o revestimento TiAlSiN oferece um espetacular rendimento no usinagem.

CONDIÇÕES DE CORTE ORIENTATIVAS

		Ø 2	Ø 3	Ø 4	Ø 5	Ø 6	Ø 8	Ø 10	Ø 12	Ø 14	Ø 16	Ø 20	Ø 25
	RPM	5600	3640	2800	2240	1820	1400	1120	924	798	700	560	420
	AVANÇO (mm/min)	70	77	77	77	77	77	77	77	77	91	91	70
INOX	RPM	11200	7420	5600	4480	3640	2800	2240	1820	1540	1400	1120	840
	AVANÇO (mm/min)	77	77	77	77	84	84	84	84	84	98	98	77
Ti	RPM	11200	7420	5600	4480	3640	2800	2240	1820	1540	1400	1120	840
	AVANÇO (mm/min)	77	77	77	77	84	84	84	84	84	98	98	77
Ni	RPM	11200	7420	5600	4480	3640	2800	2240	1820	1540	1400	1120	840
	AVANÇO (mm/min)	77	77	77	77	84	84	84	84	84	98	98	77

FRESAS TÓRICAS EM METAL DURO

NEW
Ref. FMG10R
Ref. FMG54R

USO GERAL TÓRICA

MD  30°  R  CILÍNDRICO  TiAlN  2Z  4Z  Micro Grão MD

					FMG10R		FMG54R	
MATERIAL					MD	MD	MD	MD
ACABAMENTO					TiAlN	TiAlN	TiAlN	TiAlN
QUALIDADE					★★	★★	★★★	★★★
					2Z	2Z	4Z	4Z
D1 mm	D2 mm	R mm	L2 mm	L1 mm	€	€	€	€
2	6	0,2	6	50	FMG100200R0,2	27,39	FMG540200R0,2	27,39
2	6	0,5	6	50	FMG100200R0,5	27,39	FMG540200R0,5	27,39
3	6	0,2	8	50	FMG100300R0,2	27,39	FMG540300R0,2	27,39
3	6	0,5	8	50	FMG100300R0,5	27,39	FMG540300R0,5	27,39
4	6	0,2	11	50	FMG100400R0,2	27,39	FMG540400R0,2	27,39
4	6	0,5	11	50	FMG100400R0,5	27,39	FMG540400R0,5	27,39
4	6	1,0	11	50	FMG100400R1	27,39	FMG540400R1	27,39
5	6	0,2	12	50	FMG100500R0,2	27,39	FMG540500R0,2	27,39
5	6	0,5	12	50	FMG100500R0,5	27,39	FMG540500R0,5	27,39
5	6	1,0	12	50	FMG100500R1	27,39	FMG540500R1	27,39
6	6	0,2	12	50	FMG100600R0,2	27,39	FMG540600R0,2	27,39
6	6	0,5	13	50	FMG100600R0,5	27,39	FMG540600R0,5	27,39
6	6	1,0	13	50	FMG100600R1	27,39	FMG540600R1	27,39
6	6	1,5	13	50	FMG100600R1,5	27,39	FMG540600R1,5	27,39
6	6	2,0	13	50	FMG100600R2	27,39	FMG540600R2	27,39
8	8	0,2	15	60	FMG100800R0,2	37,70	FMG540800R0,2	37,70
8	8	0,5	15	60	FMG100800R0,5	37,70	FMG540800R0,5	37,70
8	8	1,0	15	60	FMG100800R1	37,70	FMG540800R1	37,70
8	8	1,5	15	60	FMG100800R1,5	37,70	FMG540800R1,5	37,70
8	8	2,0	15	60	FMG100800R2	37,70	FMG540800R2	37,70
10	10	0,5	20	72	FMG101000R0,5	51,91	FMG541000R0,5	51,91
10	10	1,0	20	72	FMG101000R1	51,91	FMG541000R1	51,91
10	10	1,5	20	72	FMG101000R1,5	51,91	FMG541000R1,5	51,91
10	10	2,0	20	72	FMG101000R2	51,91	FMG541000R2	51,91
10	10	3,0	20	72	FMG101000R3	51,91	FMG541000R3	51,91
12	12	0,5	24	75	FMG101200R0,5	73,32	FMG541200R0,5	73,32
12	12	1,0	24	75	FMG101200R1	73,32	FMG541200R1	73,32
12	12	1,5	24	75	FMG101200R1,5	73,32	FMG541200R1,5	73,32
12	12	2,0	24	75	FMG101200R2	73,32	FMG541200R2	73,32
12	12	3,0	24	75	FMG101200R3	73,32	FMG541200R3	73,32
16	16	0,5	30	92	FMG101600R0,5	137,63	FMG541600R0,5	137,63
16	16	1,0	30	92	FMG101600R1	137,63	FMG541600R1	137,63
16	16	2,0	30	92	FMG101600R2	137,63	FMG541600R2	137,63
16	16	3,0	30	92	FMG101600R3	137,63	FMG541600R3	137,63
16	16	4,0	30	92	FMG101600R4	137,63	FMG541600R4	137,63

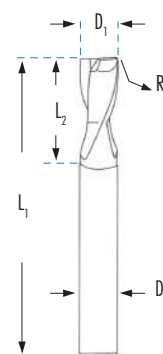

Fresas
Rosa

FRESAS DE METAL DURO MICROMÉTRICA COM OU SEM COLARINHO

FRESAS

NEW

Ref. FMD22
Ref. FMD35

**USO
GENERAL
MICRO**

MD



**30°
N**



CILÍNDRICO

TiAlN

2Z



**Micro Grão
MD**

SEM COLARINHO



**44
HRc**

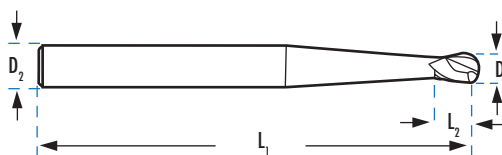

FRESAS ESFÉRICAS

FMD22

FMD35

	TOL -0,015		TOL h6			€
	D ₁ mm	D ₂ mm	L ₂ mm	L ₁ mm		
FMD220020X04	0,2	4	0,4	50	38,57	
FMD220030X06	0,3	4	0,6	50	36,78	
FMD220040X08	0,4	4	0,8	50	34,41	
FMD220050X10	0,5	4	1,0	50	32,50	
FMD220060X12	0,6	4	1,2	50	32,50	
FMD220070X14	0,7	4	1,4	50	32,50	
FMD220080X16	0,8	4	1,6	50	32,50	
FMD220090X18	0,9	4	1,8	50	32,50	

	TOL -0,015		TOL h6			€
	D ₁ mm	D ₂ mm	L ₂ mm	L ₁ mm		
FMD350020X04	0,2	4	0,4	50	48,45	
FMD350030X06	0,3	4	0,6	50	44,63	
FMD350040X08	0,4	4	0,8	50	39,09	
FMD350050X10	0,5	4	1,0	50	37,21	
FMD350060X12	0,6	4	1,2	50	37,21	
FMD350070X14	0,7	4	1,4	50	37,21	
FMD350080X16	0,8	4	1,6	50	37,21	
FMD350090X18	0,9	4	1,8	50	37,21	

COM COLARINHO



**44
HRc**

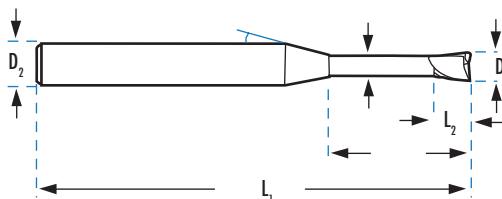

FRESAS ESFÉRICAS

FMD22

FMD35

	TOL -0,015		TOL h6				€
	D ₁ mm	D ₂ mm	D ₃ mm	L ₃ mm	L ₂ mm	L ₁ mm	
FMD220050X04	0,5	4	0,48	4	0,7	50	34,58
FMD220500X06	0,5	4	0,48	6	0,7	50	34,58
FMD220060X04	0,6	4	0,57	4	0,9	50	34,58
FMD220060X06	0,6	4	0,57	6	0,9	50	34,58
FMD220060X08	0,6	4	0,57	8	0,9	50	34,58
FMD220080X06	0,8	4	0,76	6	1,2	50	34,58
FMD220080X08	0,8	4	0,76	8	1,2	50	34,58
FMD220080X10	0,8	4	0,76	10	1,2	50	34,58
FMD220120X06	1,2	4	1,15	6	1,8	50	23,40
FMD220120X08	1,2	4	1,15	8	1,8	50	23,40
FMD220120X10	1,2	4	1,15	10	1,8	50	23,40

	TOL -0,015		TOL h6				€
	D ₁ mm	D ₂ mm	D ₃ mm	L ₃ mm	L ₂ mm	L ₁ mm	
FMD350050X04	0,5	4	0,48	4	0,7	50	41,86
FMD350050X06	0,5	4	0,48	6	0,7	50	41,86
FMD350060X04	0,6	4	0,57	4	0,9	50	41,86
FMD350060X06	0,6	4	0,57	6	0,9	50	41,86
FMD350060X08	0,6	4	0,57	8	0,9	50	41,86
FMD350080X06	0,8	4	0,76	6	1,2	50	41,86
FMD350080X08	0,8	4	0,76	8	1,2	50	41,86
FMD350080X10	0,8	4	0,76	10	1,2	50	41,86
FMD350120X06	1,2	4	1,15	6	1,8	50	24,44
FMD350120X08	1,2	4	1,15	8	1,8	50	24,44
FMD350120X10	1,2	4	1,15	10	1,8	50	24,44

FRESAS FRONTAIS DE METAL DURO COM COLARINHO

NEW
Ref. FMD22
Ref. FMD44
Ref. FMD35

USO GERAL MICRO

MD  30°  CILÍNDRICO  TiAlN   Ø 1-5 mm

Micro Grão MD

Fresas
Rosa

MATERIAL							FMD22		FMD44		FMD35	
ACABAMENTO							MD	MD	MD	MD	MD	MD
QUALIDADE							TiAlN	TiAlN	TiAlN	TiAlN	TiAlN	TiAlN
							★★	★★★	★★★	★★	★★	★★
							2Z	4Z	4Z	2Z	2Z	2Z
D1 mm	D2 mm	D3 mm	L3 mm	L2 mm	L1 mm		€	€	€	€	€	
1,0	6	0,95	5	1,5	57	FMD220100X05	32,07	FMD440100X05		FMD350100X05	32,85	
1,0	6	0,95	8	1,5	57	FMD220100X08	32,07	FMD440100X08		FMD350100X08	33,80	
1,0	6	0,95	10	1,5	57	FMD220100X10	32,07	FMD440100X10		FMD350100X10	33,80	
1,0	6	0,95	12	1,5	65	FMD220100X12	33,80	FMD440100X12		FMD350100X12	35,36	
1,0	6	0,95	15	1,5	65	FMD220100X15	33,80	FMD440100X15		FMD350100X15	35,36	
1,0	6	0,95	20	1,5	65	FMD220100X20	33,80	FMD440100X20		FMD350100X20	35,36	
1,5	6	1,42	5	2,0	57	FMD220150X05	32,07	FMD440150X05		FMD350150X05	33,80	
1,5	6	1,42	8	2,0	57	FMD220150X08	32,07	FMD440150X08		FMD350150X08	33,80	
1,5	6	1,42	10	2,0	57	FMD220150X10	32,07	FMD440150X10		FMD350150X10	33,80	
1,5	6	1,42	12	2,0	65	FMD220150X12	33,80	FMD440150X12		FMD350150X12	35,36	
1,5	6	1,42	15	2,0	65	FMD220150X15	33,80	FMD440150X15		FMD350150X15	35,36	
1,5	6	1,42	20	2,0	65	FMD220150X20	33,80	FMD440150X20		FMD350150X20	35,36	
1,5	6	1,42	25	2,0	65	FMD220150X25	33,80	FMD440150X25		FMD350150X25	-	
2,0	6	1,92	6	3,0	57	FMD220200X06	32,07	FMD440200X06	32,07	FMD350200X06	33,80	
2,0	6	1,92	8	3,0	57	FMD220200X08	32,07	FMD440200X08	32,07	FMD350200X08	33,80	
2,0	6	1,92	10	3,0	57	FMD220200X10	32,07	FMD440200X10	32,07	FMD350200X10	33,80	
2,0	6	1,92	12	3,0	60	FMD220200X12	32,93	FMD440200X12	32,93	FMD350200X12	33,80	
2,0	6	1,92	14	3,0	65	FMD220200X14	33,80	FMD440200X14	33,80	FMD350200X14	33,80	
2,0	6	1,92	16	3,0	65	FMD220200X16	33,80	FMD440200X16	33,80	FMD350200X16	34,63	
2,0	6	1,92	20	3,0	65	FMD220200X20	33,80	FMD440200X20	33,80	FMD350200X20	34,63	
2,0	6	1,92	25	3,0	65	FMD220200X25	33,80	FMD440200X25	33,80	FMD350200X25	34,63	
2,0	6	1,92	30	3,0	80	FMD220200X30	41,08	FMD440200X30	41,08	FMD350200X30	42,55	
2,0	6	1,92	35	2,0	80	FMD220200X35	41,08	FMD440200X35	41,08	FMD350200X35	42,55	
2,0	6	1,92	40	3,0	80	FMD220200X40	41,08	FMD440200X40	41,08	FMD350200X40	42,90	
2,0	6	1,92	50	3,0	100	FMD220200X50	44,20	FMD440200X50	44,20	FMD350200X50	46,77	
2,5	6	2,40	10	4,0	57	FMD220250X10	32,07	FMD440250X10	32,07	FMD350250X10	-	
2,5	6	2,40	16	4,0	65	FMD220250X16	33,80	FMD440250X16	33,80	FMD350250X16	-	
2,5	6	2,40	20	4,0	65	FMD220250X20	33,80	FMD440250X20	33,80	FMD350250X20	34,63	
2,5	6	2,40	30	4,0	80	FMD220250X30	41,08	FMD440250X30	41,08	FMD350250X30	42,90	
2,5	6	2,40	40	4,0	80	FMD220250X40	41,08	FMD440250X40	41,08	FMD350250X40	42,90	
3,0	6	2,90	9	5,0	57	FMD220300X09	32,07	FMD440300X09	32,07	FMD350300X09	34,63	
3,0	6	2,90	12	5,0	60	FMD220300X12	32,93	FMD440300X12	32,93	FMD350300X12	34,63	
3,0	6	2,90	15	5,0	65	FMD220300X15	33,80	FMD440300X15	33,80	FMD350300X15	34,63	
3,0	6	2,90	20	5,0	65	FMD220300X20	33,80	FMD440300X20	33,80	FMD350300X20	34,63	
3,0	6	2,90	25	5,0	65	FMD220300X25	33,80	FMD440300X25	33,80	FMD350300X25	35,36	
3,0	6	2,90	30	5,0	80	FMD220300X30	41,08	FMD440300X30	41,08	FMD350300X30	42,90	
3,0	6	2,90	35	5,0	80	FMD220300X35	41,08	FMD440300X35	41,08	FMD350300X35	42,90	
3,0	6	2,90	40	5,0	80	FMD220300X40	41,08	FMD440300X40	41,08	FMD350300X40	42,90	
3,0	6	2,90	50	5,0	100	FMD220300X50	44,20	FMD440300X50	44,20	FMD350300X50	46,77	
4,0	6	3,90	10	6,0	57	FMD220400X10	32,07	FMD440400X10	32,07	FMD350400X10	33,80	
4,0	6	3,90	12	6,0	60	FMD220400X12	32,93	FMD440400X12	32,93	FMD350400X12	34,63	
4,0	6	3,90	16	6,0	65	FMD220400X16	33,80	FMD440400X16	33,80	FMD350400X16	34,63	
4,0	6	3,90	20	6,0	65	FMD220400X20	33,80	FMD440400X20	33,80	FMD350400X20	34,63	
4,0	6	3,90	25	6,0	65	FMD220400X25	33,80	FMD440400X25	33,80	FMD350400X25	35,36	
4,0	6	3,90	30	6,0	80	FMD220400X30	41,08	FMD440400X30	41,08	FMD350400X30	42,90	
4,0	6	3,90	35	6,0	80	FMD220400X35	41,08	FMD440400X35	41,08	FMD350400X35	42,90	
4,0	6	3,90	40	6,0	80	FMD220400X40	41,08	FMD440400X40	41,08	FMD350400X40	42,90	
4,0	6	3,90	50	6,0	100	FMD220400X50	44,20	FMD440400X50	44,20	FMD350400X50	46,77	
5,0	6	4,80	12	7,0	60	FMD220500X12	32,93	FMD440500X12	32,93	FMD350500X12	-	
5,0	6	4,80	20	7,0	65	FMD220500X20	33,80	FMD440500X20	33,80	FMD350500X20	34,63	
5,0	6	4,80	30	7,0	80	FMD220500X30	41,08	FMD440500X30	41,08	FMD350500X30	42,90	
5,0	6	4,80	40	7,0	80	FMD220500X40	41,08	FMD440500X40	41,08	FMD350500X40	42,90	
5,0	6	4,80	50	7,0	100	FMD220500X50	44,20	FMD440500X50	44,20	FMD350500X50	46,77	

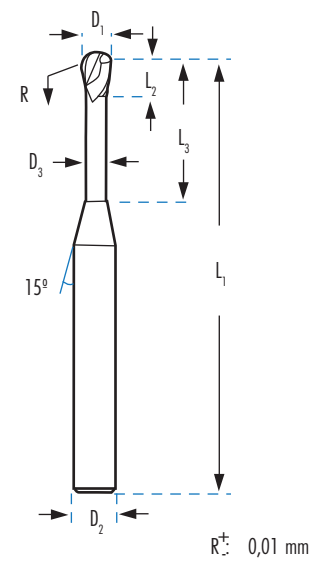

FRESAS FRONTAIS DE MD INTEGRAL, DESBASTE MEIO

USO
GERAL

MD



CILÍNDRICO

TiAlN

56
HRc

SÉRIE CURTA

FMD3					
D ₁ mm	D ₂ mm	L ₁ mm	L ₂ mm	Z	€
TOL D ₁ +0 -0,05	TOL D ₂ h6				
6	6	50	16	4	35,85
8	8	60	19	4	48,58
10	10	75	22	4	74,76
12	12	75	26	4	102,61
16	16	92	32	4	233,43
20	20	100	38	4	349,80



SÉRIE LONGA

FMD43					
D ₁ mm	D ₂ mm	L ₁ mm	L ₂ mm	Z	€
TOL D ₁ +0 -0,05	TOL D ₂ h6				
6	6	80	25	4	51,95
8	8	90	35	4	72,59
10	10	100	45	4	110,55
12	12	100	50	4	146,00
16	16	150	65	4	337,03
20	20	150	70	4	515,70



FRESAS FRONTAIS DE MD INTEGRAL, DESBASTE FINO GROSSO

USO
GERAL

MD



CILÍNDRICO

USO
GERAL

MD



CILÍNDRICO

56
HRc

FMD1					
D ₁ mm	D ₂ mm	L ₁ mm	L ₂ mm	Z	€
TOL D ₁ +0 -0,05	TOL D ₂ h6				
6	6	63	19	3	29,03 *
8	8	63	19	3	31,16 *
12	12	75	25	4	50,31 *
16	16	88	32	4	86,09 *
20	20	100	38	4	100,77 *



*Até o fim das existências.

FMD6					
D ₁ mm	D ₂ mm	L ₁ mm	L ₂ mm	Z	€
TOL D ₁ +0 -0,05	TOL D ₂ h6				
6	6	63	19	3	29,03 *
8	8	63	19	3	31,16 *
12	12	75	25	4	50,31 *
16	16	88	32	4	86,09 *
20	20	100	38	4	100,77 *



*Até o fim das existências.

FRESA FRONTAL 2 NAVALHAS, SÉRIE CURTA, HÉLICE A 30°

Ref. FMG10

INOX

Ti



55
HRc

MD



30°



CILÍNDRICO

TiAlN

2 Z



Micro Grão
MD

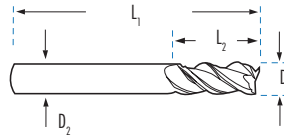

SÉRIE CURTA

REVOLUÇÕES E AVANÇOS

R.P.M. rev./min	AVANÇO mm/min	R.P.M. rev./min	AVANÇO mm/min	INOX	
				R.P.M. rev./min	AVANÇO mm/min
21.500	170	12.900	101	10.750	84
15.000	180	9.000	107	7.500	89
11.560	190	7.560	120	6.300	90
8.920	210	5.560	140	4.620	120
7.560	300	4.620	180	3.880	150
6.300	320	3.780	190	3.160	160
5.560	350	3.360	220	2.840	180
4.880	385	2.940	220	2.470	180
4.200	380	2.520	200	2.100	180
3.730	375	2.260	190	1.890	180
3.260	330	2.000	160	1.680	160
2.740	280	1.680	130	1.360	130
2.470	265	1.520	125	1.210	125
2.200	220	1.360	110	1.060	110
1.680	170	1.060	80	840	80
1.360	130	840	70	680	60

	TOL -0,03		TOL h6		L1 mm	L2 mm	€
	D1 mm	D2 mm	D1 mm	D2 mm			
FMG100100	1,0	6	40	2,5			25,99*
FMG100150	1,5	6	40	4,0			25,99*
FMG100200	2,0	6	50	6,0			38,62
FMG100300	3,0	6	50	8,0			38,62
FMG100400	4,0	6	50	11,0			38,62
FMG100500	5,0	6	50	12,0			38,62
FMG100600	6,0	6	50	12,0			38,62
FMG100700	7,0	8	60	16,0			35,78*
FMG100800	8,0	8	60	15,0			53,15
FMG100900	9,0	10	70	19,0			49,27*
FMG101000	10,0	10	72	20,0			73,20
FMG101200	12,0	12	75	24,0			103,39
FMG101400	14,0	14	85	26,0			119,86*
FMG101600	16,0	16	92	30,0			194,05
FMG102000	20,0	20	105	38,0			155,40*
FMG102500	25,0	25	120	45,0			202,30*



*Até o fim das existências.

FRESA FRONTAL 3 NAVALHAS, SÉRIE CURTA, HÉLICE VARIÁVEL

Ref. FMD67

INOX

Ti



55
HRc

MD



35°
38°



CILÍNDRICO

TiAlSiN

3 Z



Micro Grão
MD

SÉRIE CURTA

	TOL e8		TOL h6		L1 mm	L2 mm	€
	D1 mm	D2 mm	D1 mm	D2 mm			
FMD670300	3	6	50	8			32,66
FMD670400	4	6	50	11			32,66
FMD670500	5	6	50	13			32,66
FMD670600	6	6	50	16			32,66
FMD670800	8	8	60	19			41,18
FMD671000	10	10	73	22			60,84
FMD671200	12	12	75	26			82,99
FMD671400	14	14	85	30			148,11
FMD671600	16	16	92	32			161,62
FMD672000	20	20	100	38			238,37



Fresa frontal 3 navalhas, Hélice variável com revestimento de TiAlSiN.

O seu ângulo de hélice variável, minimiza as vibrações e juntamente com o revestimento de TiAlSiN, oferece um desempenho de maquinação espetacular.

FRESA FRONTAL 4 NAVALHAS, SÉRIE CURTA, HÉLICE VARIÁVEL
INOX
**INOX
AISI 316L**
Ti
INC

**55
HRc**
MD

TiAlSiN
4 Z

**Micro Grão
MD**

Ref. FMG12

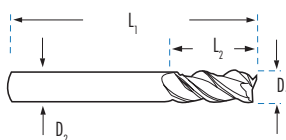
SÉRIE CURTA

REVOLUÇÕES E AVANÇOS

R.P.M. rev./min	AVANÇO mm/min	R.P.M. rev./min	AVANÇO mm/min	R.P.M. rev./min	AVANÇO mm/min	FMG12					
						TOL -0,03 D1 mm	TOL h6 D2 mm	L1 mm	L2 mm	€	
11.560	280	7.560	170	6.300	140	FMG120200	2,0	6	40	*6	21,98*
10.240	300	6.560	185	5.460	155	FMG120250	2,5	6	40	*8	21,98*
8.920	320	5.560	200	4.620	170	FMG120300	3,0	6	50	8	32,66
7.560	570	4.620	350	3.880	280	FMG120400	4,0	6	50	11	32,66
6.300	600	3.780	360	3.160	300	FMG120500	5,0	6	50	13	32,66
5.560	660	3.360	410	2.840	330	FMG120600	6,0	6	50	16	32,66
4.200	710	2.520	380	2.100	350	FMG120800	8,0	8	60	19	41,18
3.730	660	2.260	340	1.890	325	FMG120900	9,0	10	70	*19	40,95*
3.260	610	2.000	300	1.680	300	FMG121000	10,0	10	73	22	60,84
2.740	520	1.680	250	1.360	240	FMG121200	12,0	12	75	26	82,99
2.470	465	1.520	225	1.210	220	FMG121400	14,0	14	85	30	113,36
2.200	410	1.360	200	1.060	200	FMG121600	16,0	16	92	32	161,62
1.940	365	1.210	180	950	175	FMG121800	18,0	18	92	38	238,37
1.680	320	1.060	160	840	150	FMG122000	20,0	20	100	38	238,37



*Até o fim das existências.

Fresa para materiais de alta dureza. Fresa frontal 4 navalhas, corte ao centro. Hélice variável com revestimento de TiAlSiN. O seu ângulo de hélice variável, minimiza as vibrações e juntamente com o revestimento de TiAlSiN, oferece um desempenho de maquinação espetacular.

FRESA FRONTAL 4 NAVALHAS DE HÉLICE VARIÁVEL
INOX
**INOX
AISI 316L**
Ti
INC
MD

TiAlSiN
4 Z

**Micro Grão
MD**

Ref. FMG83

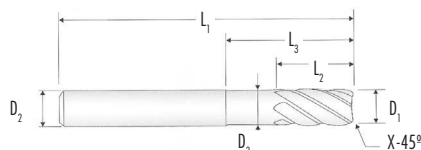
REVOLUÇÕES E AVANÇOS

R.P.M. rev./min	AVANÇO mm/min	R.P.M. rev./min	AVANÇO mm/min	FMG83							
				TOL -0,03 D1 mm	TOL h6 D2 mm	L1 mm	L2 mm	L3 mm	X-45°	€	
10.185	195	14.260	205	FMG830300	3,0	6	57	8	11	0,07	55,21
7.600	250	14.260	255	FMG830400	4,0	6	57	11	14	0,09	55,21
6.110	310	8.655	310	FMG830500	5,0	6	57	13	16	0,12	55,21
5.095	360	7.130	360	FMG830600	6,0	6	57	13	21	0,20	55,21
3.820	435	5.345	465	FMG830800	8,0	8	63	19	27	0,25	70,73
3.055	590	4.275	585	FMG831000	10,0	10	73	22	32	0,35	103,25
2.545	565	3.565	565	FMG831200	12,0	12	83	26	38	0,40	139,16
2.180	520	3.055	520	FMG831400	14,0	14	84	30	40	0,40	199,71
1.910	480	2.670	480	FMG831600	16,0	16	92	32	44	0,40	234,54
1.525	470	2.140	470	FMG832000	20,0	20	104	38	55	0,40	370,81



Fresa para materiais com alto conteúdo de níquel. Fresa frontal 4 navalhas, corte ao centro com chanfro de 45° na corte, Hélice variável com revestimento de TiAlSiN. O seu ângulo de hélice variável, minimiza as vibrações e juntamente com o revestimento de TiAlSiN, oferece um desempenho de maquinação espetacular.

FRESA MULTIUSOS

NEW

Ref. FMG80

**TOP MULTI
MATERIAIS**



MD



TiAlN

4 Z



Micro Grão
MD

SÉRIE CURTA

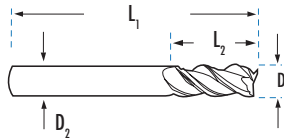

							FMG80
	TOL e8	TOL h6					
	D1 mm	D2 mm	D3 mm	L1 mm	L2 mm	L3 mm	€
FMG800300	3	6	8	20	0,05	57	36,66
FMG800400	4	6	11	20	0,05	57	36,66
FMG800500	5	6	13	21	0,07	57	36,66
FMG800600	6	6	13	21	0,10	57	36,66
FMG800800	8	8	19	27	0,15	63	44,81
FMG801000	10	10	22	32	0,15	73	65,00
FMG801200	12	12	26	38	0,25	83	92,25
FMG801400	14	14	30	40	0,30	84	117,26
FMG801600	16	16	32	44	0,35	92	164,49
FMG801800	20	20	38	55	0,35	104	242,32



Fresa frontal 4 navalhas, corte ao centro, hélice variável com revestimento de TiAlN.

O seu ângulo de hélice variável, minimiza as vibrações e juntamente com o revestimento de TiAlN, oferece um desempenho de maquinação espetacular.

FRESA ESFÉRICA DE 4 LÂMINAS ESPECIAL PARA MOLDES

NEW

Ref. FMG86

**PARA
MOLDES**

INOX

Ti



MD



TiAlSiN

4 Z



Micro Grão
MD

SÉRIE CURTA

					FMG86
	TOL e8	TOL h6			
	D1 mm	D2 mm	L1 mm	L2 mm	€
FMG860600	6	6	8	50	33,28
FMG860600X80	6	6	8	80	43,65
FMG860600X100	6	6	8	100	48,07
FMG860600X150	6	6	8	150	63,34
FMG860800	8	8	10	60	42,61
FMG860800X100	8	8	10	100	60,39
FMG860800X150	8	8	10	150	81,52
FMG861000	10	10	13	72	62,99
FMG861000X100	10	10	13	100	86,79
FMG861000X150	10	10	13	150	115,72
FMG861000X200	10	10	13	200	162,52
FMG861200	12	12	15	75	86,27
FMG861200X100	12	12	15	100	121,56
FMG861200X150	12	12	15	150	169,26
FMG861200X200	12	12	15	200	198,41



FRESA FRONTAL 6 NAVALHAS, HÉLICE A 45°
INOX

**65
HRc**
Ti
MD

45°
TiAlN
6 Z

 Materiais muito duros
 Aços endurecidos.

**Micro Grão
MD**

Ref. FMG14

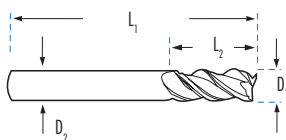
SÉRIE CURTA
REVOLUÇÕES E AVANÇOS

R.P.M. rev./min	AVANÇO mm/min	30-45 HRc		INOX		INC	
		R.P.M. rev./min	AVANÇO mm/min	R.P.M. rev./min	AVANÇO mm/min	R.P.M. rev./min	AVANÇO mm/min
8.900	2.670	5.760	1.555	4.850	1.310	2.100	370
7.560	2.260	4.800	1.440	4.100	1.230	1.800	325
6.300	2.090	4.050	1.215	3.700	1.180	1.580	300
5.560	2.000	3.880	1.370	3.370	1.100	1.350	280
4.200	2.000	2.940	1.370	2.490	1.100	1.000	280
3.360	2.000	2.320	1.370	1.920	1.100	440	280
2.840	1.680	2.000	1.160	1.610	1.000	400	250
2.470	1.470	1.740	1.020	1.380	885	355	220
2.100	1.260	1.480	880	1.160	770	310	190
1.890	1.130	1.320	785	1.030	695	280	170
1.680	1.010	1.160	690	900	920	250	155
1.500	900	1.100	600	850	540	220	135

FMG14

	TOL -0,03	TOL h6	D1 mm	D2 mm	L1 mm	L2 mm	€
FMG140300	3,0	3	38	8	24,53		
FMG140400	4,0	4	50	11	27,14		
FMG140500	5,0	5	50	13	34,32		
FMG140600	6,0	6	50	16	35,21		
FMG140800	8,0	8	60	19	49,25		
FMG141000	10,0	10	75	22	68,69		
FMG141200	12,0	12	75	26	100,58		
FMG141400	14,0	14	90	32	129,82		
FMG141600	16,0	16	100	32	177,13		
FMG141800	18,0	18	100	38	205,60		
FMG142000	20,0	20	100	38	256,50		
FMG142500	25,0	25	100	38	437,21		

SÉRIE LONGA
REVOLUÇÕES E AVANÇOS

R.P.M. rev./min	AVANÇO mm/min	30-45 HRc		INOX		INC	
		R.P.M. rev./min	AVANÇO mm/min	R.P.M. rev./min	AVANÇO mm/min	R.P.M. rev./min	AVANÇO mm/min
8.900	2.670	5.760	1.555	4.850	1.310	2.100	370
7.560	2.260	4.800	1.440	4.100	1.230	1.800	325
6.300	2.090	4.050	1.215	3.700	1.180	1.580	300
5.560	2.000	3.880	1.370	3.370	1.100	1.350	280
4.200	2.000	2.940	1.370	2.490	1.100	1.000	280
3.360	2.000	2.320	1.370	1.920	1.100	440	280
2.840	1.680	2.000	1.160	1.610	1.000	400	250
2.840	1.680	2.000	1.160	1.610	1.000	400	250
2.470	1.470	1.740	1.020	1.380	885	355	220
2.100	1.260	1.480	880	1.160	770	310	190
2.100	1.260	1.480	880	1.160	770	310	190
1.680	1.010	1.160	690	900	920	250	155
1.680	1.010	1.160	690	900	920	250	155
1.680	1.010	1.160	690	900	920	250	155
1.500	900	1.100	600	850	540	220	135
1.500	900	1.100	600	850	540	220	135
1.500	900	1.100	600	850	540	220	135

FMG25

	TOL -0,03	TOL h6	D1 mm	D2 mm	L1 mm	L2 mm	€
FMG250300	3,0	3	60	15	24,18		
FMG250400	4,0	4	80	20	27,25		
FMG250500	5,0	5	80	25	31,29		
FMG250600	6,0	6	80	25	37,94		
FMG250800	8,0	8	90	35	55,41		
FMG251000	10,0	10	100	45	75,00		
FMG251200	12,0	12	100	50	107,15		
FMG251200X125	12,0	12	125	70	132,67		
FMG251400	14,0	14	150	65	145,65		
FMG251600	16,0	16	150	65	187,15		
FMG251600X165	16,0	16	165	100	213,60		
FMG252000	20,0	20	150	70	276,78		
FMG252000X165	20,0	20	165	100	319,26		
FMG252000X200	20,0	20	200	135	408,06		
FMG252500	25,0	25	150	75	532,10		
FMG252500X165	25,0	25	165	100	616,06		
FMG252500X200	25,0	25	200	140	690,82		
FMG253200	32,0	32	165	100	863,55		
FMG253200X210	32,0	32	210	150	1.036,13		



FRESA FRONTAL 2 E 3 NAVALHAS, SÉRIE CURTA, HÉLICE A 45°, PARA ALUMÍNIO

Al

Cu

PVC



45° N



CILÍNDRICO

2Z



Ref. FMD59

3Z



Ref. FMD33

Micro Grão
MD

SÉRIE CURTA

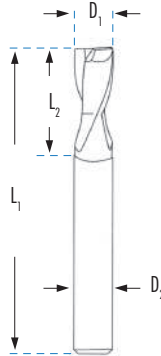

REVOLUÇÕES E AVANÇOS							FMD59	FMD33
Al			TOL -0,05	TOL h6			2Z	3Z
R.P.M rev./min.	AVANÇO 1 mm/min	AVANÇO 2 mm/min	D1 mm	D2 mm	L1 mm	L2 mm	€	€
10.000	700	900	3,0	6,0	50	8	FMD590300 27,60	FMD330300 27,60
10.000	900	1.100	4,0	6,0	50	11	FMD590400 29,90	FMD330400 29,90
10.000	1.000	1.300	5,0	6,0	50	13	FMD590500 30,89	FMD330500 30,89
10.000	1.200	1.500	6,0	6,0	50	16	FMD590600 35,07	FMD330600 35,07
8.000	1.400	1.800	8,0	8,0	60	19	FMD590800 49,97	FMD330800 49,97
8.000	1.700	2.100	10,0	10,0	72	25	FMD591000 73,47	FMD331000 73,47
8.000	2.100	2.600	12,0	12,0	75	30	FMD591200 97,07	FMD331200 97,07
6.000	1.800	2.200	14,0	14,0	84	35	FMD591400 136,23	FMD331400 136,23
6.000	1.900	2.400	16,0	16,0	92	40	FMD591600 172,80	FMD331600 172,80
4.000	1.600	1.900	20,0	20,0	100	45	FMD592000 284,99	FMD332000 284,99

TOLERÂNCIAS CONFORME DIN 7160 e 7161

Gama de tolerâncias μm / Diâmetro nominal em mm

	de 1 a 3	de 3 a 6	de 6 a 10	de 10 a 18	de 18 a 30
TOL	0	0	0	0	0
h10	- 40	- 48	- 58	- 70	- 84
TOL	0	0	0	0	0
h6	- 6	- 8	- 9	- 11	- 13

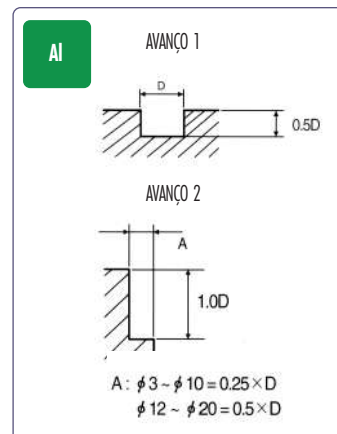



FRESA FRONTAL 2 E 3 NAVALHAS, SÉRIE LONGA, HÉLICE A 45°, PARA ALUMÍNIO

NEW

Al

Cu

PVC



45° N

CILÍNDRICO

2 Z



Ref. FMD69

3 Z



Ref. FMD23

Micro Grão
MD

SÉRIE LONGA

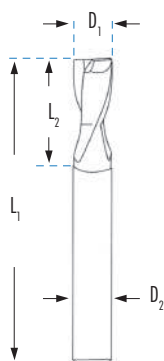

REVOLUÇÕES E AVANÇOS

Al

							FMD69		FMD23	
			TOL -0,05	TOL h6				2 Z		3 Z
R.P.M. rev./min.	AVANÇO 1 mm/min	AVANÇO 2 mm/min	D1 mm	D2 mm	L1 mm	L2 mm		€		€
10.000	1.200	1.500	6,0	6,0	80	25	FMD690600	40,33	FMD230600	40,33
8.000	1.400	1.800	8,0	8,0	90	35	FMD690800	57,47	FMD230800	57,47
8.000	1.700	2.100	10,0	10,0	100	45	FMD691000	84,49	FMD231000	84,49
8.000	2.100	2.600	12,0	12,0	100	50	FMD691200	111,63	FMD231200	111,63
6.000	1.800	2.200	14,0	14,0	165	65	FMD691400	156,66	FMD231400	156,66
6.000	1.900	2.400	16,0	16,0	150	65	FMD691600	198,72	FMD231600	198,72
4.000	1.600	1.900	20,0	20,0	150	70	FMD692000	327,74	FMD232000	327,74

TOLERÂNCIAS CONFORME DIN 7160 e 7161

Gama de tolerâncias μm / Diâmetro nominal em mm					
	de 1 a 3	de 3 a 6	de 6 a 10	de 10 a 18	de 18 a 30
TOL	0	0	0	0	0
h10	- 40	- 48	- 58	- 70	- 84
TOL	0	0	0	0	0
h6	- 6	- 8	- 9	- 11	- 13

Al

AVANÇO 1

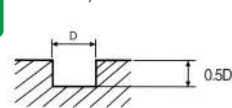

AVANÇO 2

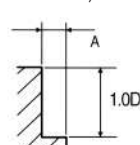
A: $\phi 3 - \phi 10 = 0.25 \times D$
 $\phi 12 - \phi 20 = 0.5 \times D$

FRESA FRONTAL 2 NAVALHAS ESFÉRICA, SÉRIE CURTA E LONGA, HÉLICE A 45°, PARA ALUMÍNIO



Ref. FMD93
Ref. FMD94

Micro Grão
MD

SÉRIE CURTA

REVOLUÇÕES E AVANÇOS			FMD93						
AI			TOL -0,05	TOL h6					2Z
R.P.M rev./min.	AVANÇO 1 mm/min	AVANÇO 2 mm/min	D1 mm	D2 mm	L1 mm	L2 mm		€	
10.000	700	900	3,0	6,0	50	6	FMD930300	25,20	
10.000	900	1.100	4,0	6,0	50	8	FMD930400	28,72	
10.000	1.000	1.300	5,0	6,0	50	10	FMD930500	30,38	
10.000	1.200	1.500	6,0	6,0	50	12	FMD930600	35,75	
8.000	1.400	1.800	8,0	8,0	60	15	FMD930800	44,13	
8.000	1.700	2.100	10,0	10,0	72	20	FMD931000	66,32	
8.000	2.100	2.600	12,0	12,0	75	24	FMD931200	82,39	
6.000	1.800	2.200	14,0	14,0	83	26	FMD931400	121,97	
6.000	1.900	2.400	16,0	16,0	92	30	FMD931600	154,32	
4.000	1.600	1.900	20,0	20,0	100	40	FMD932000	237,86	

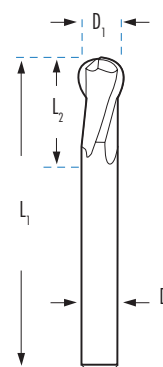

SÉRIE LONGA

REVOLUÇÕES E AVANÇOS			FMD94							
AI			TOL -0,05	TOL h6					2Z	
R.P.M rev./min.	AVANÇO 1 mm/min	AVANÇO 2 mm/min	D1 mm	D2 mm	D3 mm	L3 mm	L1 mm	L2 mm	€	
10.000	1.200	1.500	6,0	6,0	5,5	35	80	12	FMD940600	42,33
8.000	1.400	1.800	8,0	8,0	7,5	35	90	15	FMD940800	47,06
8.000	1.700	2.100	10,0	10,0	9,5	45	100	20	FMD941000	75,00
8.000	2.100	2.600	12,0	12,0	11,5	50	100	24	FMD941200	94,47
6.000	1.900	2.400	16,0	16,0	15,5	92	150	30	FMD941600	185,21
4.000	1.600	1.900	20,0	20,0	19,5	92	150	40	FMD942000	270,23

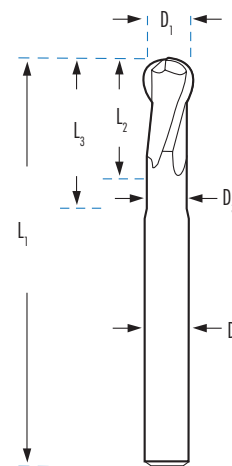

FRESA FRONTAL 3 A 4 NAVALHAS, SÉRIE CURTA, HÉLICE A 50°

Ref. FMG13

INOX
45
HRC

Ti

INC

MD



50°



WELDON

TiAlN

3-4 Z

 Micro Grão
 MD

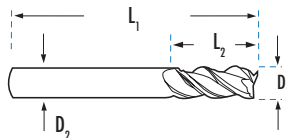
SÉRIE CURTA

REVOLUÇÕES E AVANÇOS

R.P.M. rev./min	AVANÇO mm/min								
		R.P.M. rev./min	AVANÇO mm/min	R.P.M. rev./min	AVANÇO mm/min	R.P.M. rev./min	AVANÇO mm/min	R.P.M. rev./min	AVANÇO mm/min
4.200	310	2.520	180	2.100	160	920	40		
3.260	310	2.000	140	1.680	140	740	40		
2.740	250	1.680	120	1.370	120	620	30		
2.200	200	1.360	100	1.050	100	460	25		
1.940	175	1.210	85	950	85	410	20		
1.680	150	1.060	70	840	70	350	20		
1.360	115	840	60	670	60	300	15		

FMG13

	TOL -0,03	TOL h6	L ₁ mm	L ₂ mm	Z	€
	D ₁ mm	D ₂ mm				
FMG130800	8,0	8	60	19	3	30,99*
FMG131000	10,0	10	70	22	3	45,78*
FMG131200	12,0	12	75	25	3	62,74*
FMG131600	16,0	16	90	32	3	103,96*
FMG131800	18,0	18	90	32	3	121,54*
FMG132000	20,0	20	100	28	4	137,83*
FMG132500	25,0	25	120	45	4	220,44*

*Até o fim das existências.



NOTA: nas operações de fresagem por uma face deberemos aumentar os avanços num 30%, mantendo as revoluções.

TOLERÂNCIAS CONFORME DIN 7160 e 7161

 Gama de tolerâncias μm / Diâmetro nominal em mm

	de 1 a 3	de 3 a 6	de 6 a 10	de 10 a 18	de 18 a 30
TOL e8	- 14	- 20	- 25	- 32	- 40
	- 28	- 38	- 47	- 59	- 73
TOL h6	0	0	0	0	0
	- 6	- 8	- 9	- 11	- 13

FRESAS FRONTAIS 3 A 5 NAVALHAS, DESBASTE FINO



Ref. FMG15
Ref. FMG16



Ti

INC

MD



Micro Grão
MD

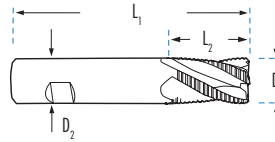

SÉRIE CURTA

REVOLUÇÕES E AVANÇOS

				INOX		INC	
R.P.M. rev./min	AVANÇO mm/min	R.P.M. rev./min	AVANÇO mm/min	R.P.M. rev./min	AVANÇO mm/min	R.P.M. rev./min	AVANÇO mm/min
15.600	2.320	12.400	840	8.400	570	2.400	190
13.600	2.320	10.800	840	7.350	570	2.100	190
11.600	2.320	9.200	840	6.300	570	1.800	190
10.400	2.320	8.400	840	5.700	570	1.550	190
9.200	2.320	7.600	840	5.100	570	1.300	190
8.000	2.400	6.000	800	4.200	570	1.200	190
6.800	2.400	5.200	840	3.600	570	900	130
6.000	2.400	4.800	760	3.300	510	800	110
4.800	2.160	3.600	560	2.400	360	660	100
4.300	2.150	3.200	620	2.160	410	600	100

FMG15

	TOL h10	TOL h6	L1 mm	L2 mm	Z	€
	D1 mm	D2 mm				
FMG150600	6,0	6	54	7	3	23,07*
FMG150700	7,0	8	58	8	3	26,96*
FMG150800	8,0	8	58	9	3	26,96*
FMG150900	9,0	10	66	13	4	40,20*
FMG151000	10,0	10	66	14	4	40,20*
FMG151200	12,0	12	73	16	4	51,57*
FMG151400	14,0	14	75	18	4	62,55*
FMG151600	16,0	16	82	22	4	83,93*
FMG152000	20,0	20	92	26	4	121,49*
FMG152500	25,0	25	110	25	5	189,26*

*Até o fim das existências.



SÉRIE LONGA

REVOLUÇÕES E AVANÇOS

				INOX		INC	
R.P.M. rev./min	AVANÇO mm/min	R.P.M. rev./min	AVANÇO mm/min	R.P.M. rev./min	AVANÇO mm/min	R.P.M. rev./min	AVANÇO mm/min
13.600	2.320	10.800	840	7.350	570	2.100	190
11.600	2.320	9.200	840	6.300	570	1.800	190
9.200	2.320	7.600	840	5.100	570	1.300	190
6.800	2.400	5.200	840	3.600	570	900	130
6.000	2.400	4.800	760	3.300	510	800	110
4.800	2.160	3.600	560	2.400	360	660	100
4.300	2.150	3.200	620	2.160	410	600	100

FMG16

	TOL h10	TOL h6	L1 mm	L2 mm	Z	€
	D1 mm	D2 mm				
FMG160700	7,0	8	63	16	3	28,97*
FMG160800	8,0	8	63	16	3	28,97*
FMG161000	10,0	10	72	22	4	43,21*
FMG161400	14,0	14	83	26	4	67,24*
FMG161600	16,0	16	92	32	4	90,23*
FMG162000	20,0	20	104	38	4	130,63*
FMG162500	25,0	25	121	45	5	203,50*

*Até o fim das existências.



TOLERÂNCIAS CONFORME DIN 7160 e 7161

Gama de tolerâncias μm / Diâmetro nominal em mm					
	de 1 a 3	de 3 a 6	de 6 a 10	de 10 a 18	de 18 a 30
TOL e8	0 - 40	0 - 48	0 - 58	0 - 70	0 - 84
TOL h6	0 - 6	0 - 8	0 - 9	0 - 11	0 - 13

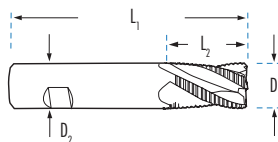
FRESA FRONTAL 4 A 6 NAVALHAS, SÉRIE CURTA, HÉLICE A 45°, DESBASTE FINO

SÉRIE CURTA
REVOLUÇÕES E AVANÇOS

REVOLUÇÕES E AVANÇOS								FMG17						
<30 HRC		30-45 HRC		INOX		INC		TOL h10	TOL h6					
R.P.M. rev./min	AVANÇO mm/min	R.P.M. rev./min	AVANÇO mm/min	R.P.M. rev./min	AVANÇO mm/min	R.P.M. rev./min	AVANÇO mm/min	D1 mm	D2 mm	L1 mm	L2 mm	Z	€	
11.600	2.320	9.200	840	6.300	570	1.800	190	FMG170800	8,0	8	58	9	4	26,96*
8.000	2.400	6.000	800	4.200	570	1.200	190	FMG171200	12,0	12	73	16	4	51,57*
6.000	2.400	4.800	760	3.300	510	800	110	FMG171600	16,0	16	82	22	5	83,93*
4.800	2.160	3.600	560	2.400	360	660	100	FMG172000	20,0	20	92	26	6	107,99*

*Até o fim das existências.

FRESA FRONTAL 3 A 6 NAVALHAS, SÉRIE LONGA, HÉLICE A 45°, DESBASTE FINO

SÉRIE LONGA
REVOLUÇÕES E AVANÇOS

REVOLUÇÕES E AVANÇOS								FMG18						
<30 HRC		30-45 HRC		INOX		INC		TOL h10	TOL h6					
R.P.M. rev./min	AVANÇO mm/min	R.P.M. rev./min	AVANÇO mm/min	R.P.M. rev./min	AVANÇO mm/min	R.P.M. rev./min	AVANÇO mm/min	D1 mm	D2 mm	L1 mm	L2 mm	Z	€	
20.100	4.600	18.400	1.700	12.600	1.040	3.800	399	FMG180400	4,0	6	57	11	3	24,07*
15.600	2.320	12.400	840	8.400	570	2.400	190	FMG180600	6,0	6	57	16	4	24,07*
13.600	2.320	10.800	840	7.350	570	2.100	190	FMG180700	7,0	8	63	16	4	28,13*
11.600	2.320	9.200	840	6.300	570	1.800	190	FMG180800	8,0	8	63	16	4	28,13*
9.200	2.320	7.600	840	5.100	570	1.300	190	FMG181000	10,0	10	72	22	4	41,95*
6.800	2.400	5.200	840	3.600	570	900	130	FMG181400	14,0	14	83	26	5	65,28*
6.000	2.400	4.800	760	3.300	510	800	110	FMG181600	16,0	16	92	32	5	87,61*
4.800	2.160	3.600	560	2.400	360	660	100	FMG182000	20,0	20	104	38	6	140,91*
4.300	2.150	3.200	620	2.160	410	600	100	FMG182500	25,0	25	121	45	6	246,97*

*Até o fim das existências.



FRESA FRONTAL 4 A 6 NAVALHAS, SÉRIE LONGA, HÉLICE A 45°, DESBASTE FINO

NF
INOX
Ref. FMG19
INC
45 HRc
MD
45°
WELDON
TiAIN
4-6 Z
Micro Grão MD

SÉRIE LONGA

FMG19								
	TOL h10	TOL h6						
	D1 mm	D2 mm	D3 mm	L1 mm	L2 mm	L3 mm	Z	€
FMG190600	6,0	6	5,5	57	16	20	4	29,72*
FMG190800	8,0	8	7,5	63	16	26	4	34,74*
FMG191000	10,0	10	9,5	72	22	31	4	51,82*
FMG191200	12,0	12	11,5	83	26	37	4	66,49*
FMG191600	16,0	16	15,5	100	32	51	5	86,66*
FMG192000	20,0	20	19,2	110	38	59	6	139,31*

*Até o fim das existências.

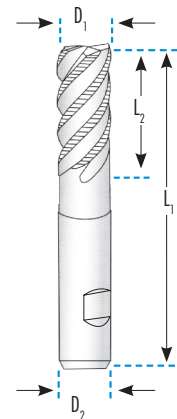

REVOLUÇÕES E AVANÇOS

R.P.M. rev./min	AVANÇO mm/ min			R.P.M. rev./min	AVANÇO mm/min	INOX		INC	
		R.P.M. rev./min	AVANÇO mm/min			R.P.M. rev./min	AVANÇO mm/min	R.P.M. rev./min	AVANÇO mm/min
15.600	2.320	12.400	840	8.400	570	2.400	190		
11.600	2.320	9.200	840	6.300	570	1.800	190		
9.200	2.320	7.600	840	5.100	570	1.300	190		
8.000	2.400	6.000	800	4.200	570	1.200	190		
6.000	2.400	4.800	760	3.300	510	800	110		
4.800	2.160	3.600	560	2.400	360	660	100		

TOLERÂNCIAS CONFORME DIN 7160 e 7161

TOL	Gama de tolerâncias μm / Diâmetro nominal em mm				
	de 1 a 3	de 3 a 6	de 6 a 10	de 10 a 18	de 18 a 30
h10	0	0	0	0	0
	- 40	- 48	- 58	- 70	- 84
h6	0	0	0	0	0
	- 6	- 8	- 9	- 11	- 13

FRESA FRONTAL DE 2 NAVALHAS PARA AÇOS DE TÊMPERA EXTREMA 70 HRc

70
HRc

Ref. FMG01

MD



30°



CILÍNDRICO

BLUE

2 Z

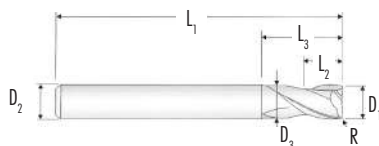
Micro Grão
MD

REVOLUÇÕES E AVANÇOS

R.P.M. rev./min.	50-55 HRc		55-60 HRc		60-65 HRc		65-70 HRc	
	AVANÇO mm/min	R.P.M. rev./min.	AVANÇO mm/min	R.P.M. rev./min.	AVANÇO mm/min	R.P.M. rev./min.	AVANÇO mm/min	R.P.M. rev./min.
25.500	360	20.500	215	16.000	135	12.500	88	
21.500	390	17.500	240	13.500	150	11.000	102	
11.500	420	9.500	260	7.500	160	6.400	115	
10.150	430	8.350	270	6.550	165	5.575	118	
8.800	440	7.200	270	5.600	170	4.750	118	
8.550	470	6.800	280	5.350	175	4.600	125	
6.900	480	5.300	280	4.200	180	3.700	130	
4.100	415	3.200	240	2.550	155	2.200	112	
3.500	415	2.650	240	2.100	155	1.860	112	
2.600	365	2.000	210	1.600	135	1.400	98	
2.050	335	1.600	295	1.300	125	1.100	88	

FMG01

TOL Especial	TOL h6		D3 mm	L1 mm	L2 mm	L3 mm	R	€
	D1 mm	D2 mm						
FMG010100	1,0	3	-	40	1,5	-	0,1	17,54*
FMG010150	1,5	3	-	40	2,2	-	0,1	17,54*
FMG010300	3,0	6	2,9	45	4,0	7	0,1	23,24*
FMG010350	3,5	6	3,3	45	5,0	9	0,1	23,24*
FMG010400	4,0	6	3,8	45	5,0	9	0,1	23,24*
FMG010450	4,5	6	4,3	45	6,0	10	0,1	23,24*
FMG010600	6,0	6	5,8	50	7,0	14	0,2	23,24*
FMG011000	10,0	10	9,7	75	12,0	25	0,2	43,92*
FMG011200	12,0	12	11,7	75	15,0	30	0,3	60,56*
FMG011600	16,0	16	15,7	90	18,0	38	0,3	100,97*
FMG012000	20,0	20	19,7	100	24,0	45	0,3	133,56*

*Até o fim das existências.



FRESA FRONTAL DE 4 NAVALHAS PARA AÇOS DE TÊMPERA EXTREMA 70 HRc

70
HRc

Ref. FMG04

MD



30°



CILÍNDRICO

BLUE

4 Z

Micro Grão
MD

REVOLUÇÕES E AVANÇOS

R.P.M. rev./min.	50-55 HRc		55-60 HRc		60-65 HRc		65-70 HRc	
	AVANÇO mm/min	R.P.M. rev./min.	AVANÇO mm/min	R.P.M. rev./min.	AVANÇO mm/min	R.P.M. rev./min.	AVANÇO mm/min	R.P.M. rev./min.
25.500	710	20.500	430	16.000	270	12.500	175	
21.500	775	17.500	475	13.500	295	11.000	200	
17.500	840	14.500	520	11.000	320	9.500	230	
11.500	840	9.500	520	7.500	320	6.400	230	
10.150	860	8.350	530	6.550	328	5.575	240	
8.800	880	7.200	540	5.600	335	4.750	240	
8.550	940	6.800	560	5.350	353	4.600	255	
6.900	950	5.300	560	4.200	350	3.700	260	
4.100	840	3.200	480	2.550	310	2.200	220	
3.500	840	2.650	480	2.100	300	1.860	220	
2.600	730	2.000	420	1.600	270	1.400	200	
2.050	650	1.600	380	1.300	250	1.100	180	

FMG04

TOL Especial	TOL h6		D3 mm	L1 mm	L2 mm	L3 mm	R	€
	D1 mm	D2 mm						
FMG040100	1,0	3	-	40	1,5	-	0,1	17,54*
FMG040150	1,5	3	-	40	2,2	-	0,1	17,54*
FMG040200	2,0	3	1,9	40	3,0	6	0,1	15,91*
FMG040300	3,0	6	2,9	45	4,0	7	0,1	23,24*
FMG040350	3,5	6	3,3	45	5,0	9	0,1	23,24*
FMG040400	4,0	6	3,8	45	5,0	9	0,1	23,24*
FMG040450	4,5	6	4,3	45	6,0	10	0,1	23,24*
FMG040600	6,0	6	5,8	50	7,0	14	0,2	23,24*
FMG041000	10,0	10	9,7	75	12,0	25	0,2	43,92*
FMG041200	12,0	12	11,7	75	15,0	30	0,3	60,56*
FMG041600	16,0	16	15,7	90	18,0	38	0,3	100,97*
FMG042000	20,0	20	19,7	100	24,0	45	0,3	133,56*

*Até o fim das existências.



FRESA FRONTAL DE 2 NAVALHAS BOLEADA PARA AÇOS DE TÊMPERA EXTREMA 70 HRC



Ref. FMG02



Micro Grão MD

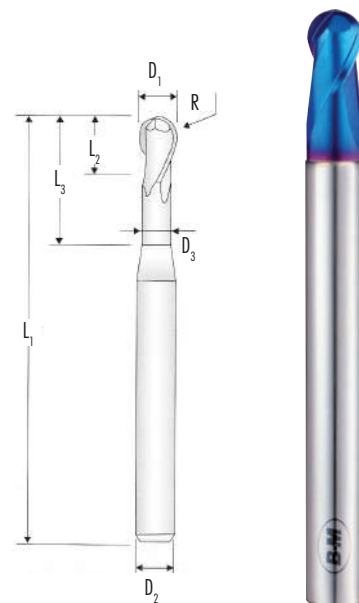

SÉRIE CURTA

REVOLUÇÕES E AVANÇOS

50-55 HRc		55-60 HRc		60-65 HRc		65-70 HRc	
R.P.M rev./min.	AVANÇO mm/min	R.P.M rev./min.	AVANÇO mm/min	R.P.M rev./min.	AVANÇO mm/min	R.P.M rev./min.	AVANÇO mm/min
57.000	4.000	54.000	3.400	51.000	2.700	48.000	2.300
48.500	4.000	44.500	3.275	41.500	2.750	38.250	2.300
40.000	4.000	35.000	3.150	32.000	2.800	28.500	2.300
26.500	4.000	23.500	3.150	21.000	2.800	19.000	2.300
15.000	3.750	13.500	3.050	11.500	2.550	10.500	2.100
11.000	3.100	10.000	2.500	8.800	2.150	8.000	1.750
9.000	2.700	8.000	2.150	7.000	1.850	6.500	1.550
7.500	2.400	6.600	1.900	5.800	1.650	5.300	1.380
5.600	1.900	5.000	1.550	4.400	1.250	4.000	1.050
5.000	1.800	4.500	1.450	3.950	1.125	3.600	950
4.000	1.600	3.600	1.275	3.150	900	2.875	750
3.600	1.500	3.200	1.200	2.800	800	2.550	660
-	-	-	-	-	-	-	-

FMG02

	TOL Especial		TOL h6			TOL R		€
	D1 mm	D2 mm	D3 mm	L1 mm	L2 mm	L3 mm	R	
FMG020100	1,0	4	0,95	50	1,0	2,2	0,5	28,92*
FMG020150	1,5	4	1,40	50	1,5	3,0	0,8	28,92*
FMG020200	2,0	4	1,90	50	2,0	4,0	1,0	27,46*
FMG020300	3,0	6	2,90	60	3,0	6,0	1,5	27,46*
FMG020500	5,0	6	4,90	80	5,0	10,0	2,5	29,55*
FMG020600	6,0	6	5,90	90	6,0	12,0	3,0	31,69*
FMG020800	8,0	8	7,90	100	8,0	16,0	4,0	49,45*
FMG021000	10,0	10	9,90	100	10,0	20,0	5,0	81,55*
FMG021200	12,0	12	11,90	110	12,0	24,0	6,0	104,68*
FMG021400	14,0	14	13,80	110	14,0	28,0	7,0	105,90*
FMG021800	18,0	18	17,80	140	18,0	36,0	9,0	150,96*
FMG022000	20,0	20	19,80	160	20,0	40,0	10,0	213,94*
FMG022500	25,0	25	24,80	180	25,0	50,0	12,5	346,80*

*Até o fim das existências.

TOLERÂNCIAS CONFORME DIN 7160 e 7161

	Gama de tolerâncias μm / Diâmetro nominal em mm				
	de 1 a 3	de 3 a 6	de 6 a 10	de 10 a 18	de 18 a 30
TOL Especial	0 - 12	0 - 12	0 - 15	0 - 15	0 - 15
TOL h6	0 - 6	0 - 8	0 - 9	0 - 11	0 - 13
TOL R	0 - 5	0 - 10	0 - 10	0 - 10	0 - 10

FRESA FRONTAL DE 6 NAVALHAS PARA AÇOS DE TÊMPERA EXTREMA 70 HRC



Ref. FMG06

MD



CILÍNDRICO

BLUE

6 Z

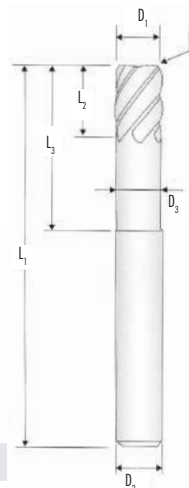
Micro Grão
MD

SÉRIE CURTA

REVOLUÇÕES E AVANÇOS

50-55 HRc		55-60 HRc		60-65 HRc		65-70 HRc	
R.P.M rev./min.	AVANÇO mm/min	R.P.M rev./min.	AVANÇO mm/min	R.P.M rev./min.	AVANÇO mm/min	R.P.M rev./min.	AVANÇO mm/min
12.000	4.600	10.000	3.100	8.000	2.000	6.000	1.400
9.500	4.100	8.000	2.900	6.400	1.800	4.800	1.300
8.000	3.800	6.600	2.500	5.300	1.600	4.000	1.150

FMG06

	TOL Especial		TOL h6				TOL R	€
	D1 mm	D2 mm	D3 mm	L1 mm	L2 mm	L3 mm	R	
FMG060800	8,0	8	7,65	60	8	24	0,5	39,65*
FMG061000	10,0	10	9,65	70	10	30	1,0	61,85*
FMG061200	12,0	12	11,60	75	12	30	1,0	73,88*

*Até o fim das existências.

SÉRIE LONGA

REVOLUÇÕES E AVANÇOS

50-55 HRc		55-60 HRc		60-65 HRc		65-70 HRc	
R.P.M rev./min.	AVANÇO mm/min	R.P.M rev./min.	AVANÇO mm/min	R.P.M rev./min.	AVANÇO mm/min	R.P.M rev./min.	AVANÇO mm/min
16.000	4.900	13.500	3.300	10.500	2.100	8.000	1.450
12.000	4.600	10.000	3.100	8.000	2.000	6.000	1.400
9.500	4.100	8.000	2.900	6.400	1.800	4.800	1.300
8.000	3.800	6.600	2.500	5.300	1.600	4.000	1.150
8.000	3.800	6.600	2.500	5.300	1.600	4.000	1.150
6.000	3.400	5.000	2.300	4.000	1.250	3.000	870
6.000	3.400	5.000	2.300	4.000	1.250	3.000	870
4.800	3.200	4.000	2.100	3.200	1.020	2.400	690
4.800	3.200	4.000	2.100	3.200	1.020	2.400	690
4.800	3.200	4.000	2.100	3.200	1.020	2.400	690

FMG07

	TOL Especial	TOL h6		R	€	
	D1 mm	D2 mm	L1 mm			L2 mm
FMG070600	6,0	6	70	13	0,5	37,77*
FMG070800	8,0	8	90	19	0,5	47,34*
FMG071000	10,0	10	100	22	0,5	71,32*
FMG071200	12,0	12	110	26	0,5	97,28*
FMG071201	12,0	12	110	26	1,0	108,95*
FMG071600	16,0	16	130	32	1,0	131,24*
FMG071601	16,0	16	130	32	1,5	143,33*
FMG072000	20,0	20	140	38	1,0	192,06*
FMG072001	20,0	20	140	38	1,5	209,81*
FMG072002	20,0	20	140	38	2,0	209,81*

*Até o fim das existências.

TOLERÂNCIAS CONFORME DIN 7160 e 7161

Gama de tolerâncias μm / Diâmetro nominal em mm					
	de 1 a 3	de 3 a 6	de 6 a 10	de 10 a 18	de 18 a 30
TOL Especial	0	0	0	0	0
	- 12	- 12	- 15	- 15	- 15
TOL h6	0	0	0	0	0
	- 6	- 8	- 9	- 11	- 13

FRESAS FRONTAIS PARA AÇOS DE TÊMPERA EXTREMA 70HRC,
TECNOLOGIA DE MICRO-FRESAGEM, PEÇAS DE PRECISÃO

70 HRc Ref. FMG09 MD 30° CILÍNDRICO BLUE 2 Z TOL D1 -0,012 TOL D2 h6 Micro Grão MD

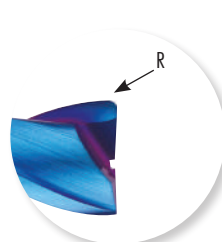
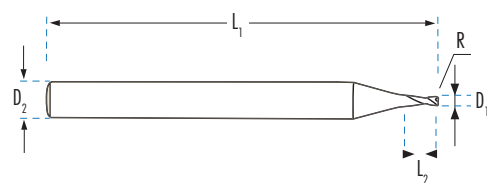

FMG09						
	D1 mm	D2 mm	L1 mm	L2 mm	R	€
FMG090040	0,40	6	50	0,60	-	63,50*
FMG090050	0,50	6	50	0,70	0,05	55,24*
FMG090060	0,60	6	50	0,90	0,05	53,14*
FMG090080	0,80	6	50	1,20	0,05	48,97*
FMG090100	1,00	6	50	1,50	0,10	46,93*
FMG090120	1,20	6	50	1,80	0,10	46,93*
FMG090150	1,50	6	50	2,20	0,15	46,93*
FMG090200	2,00	6	50	2,20	0,15	42,53*

*Até o fim das existências.

70 HRc Ref. FMG08 MD 30° CILÍNDRICO BLUE 2 Z TOL D1 -0,012 TOL D2 h6 Micro Grão MD

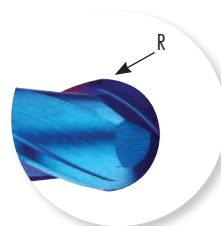
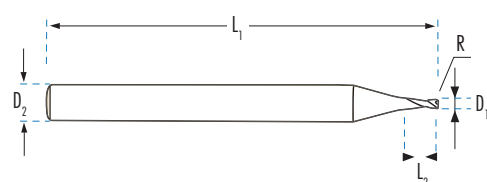

FMG08						
	D1 mm	D2 mm	L1 mm	L2 mm	R	€
FMG080040	0,40	6	50	0,40	0,20	68,68*
FMG080050	0,50	6	50	0,50	0,25	63,40*
FMG080060	0,60	6	50	0,60	0,30	58,13*
FMG080080	0,80	6	50	0,80	0,40	47,41*
FMG080100	1,00	6	50	1,00	0,50	44,64*
FMG080120	1,20	6	50	1,20	0,60	44,64*
FMG080150	1,50	6	50	1,50	0,75	44,64*
FMG080200	2,00	6	50	2,00	1,00	40,45*

*Até o fim das existências.



FRESAS FRONTAIS ESPECIAIS PARA ALUCOBOND

PMD

Ref. FFALUC

MDI

Ref. FFALUC...MDI

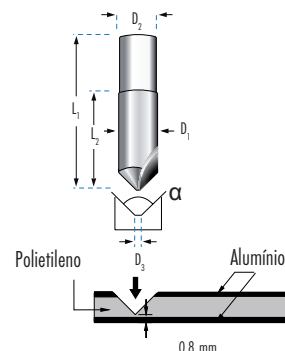
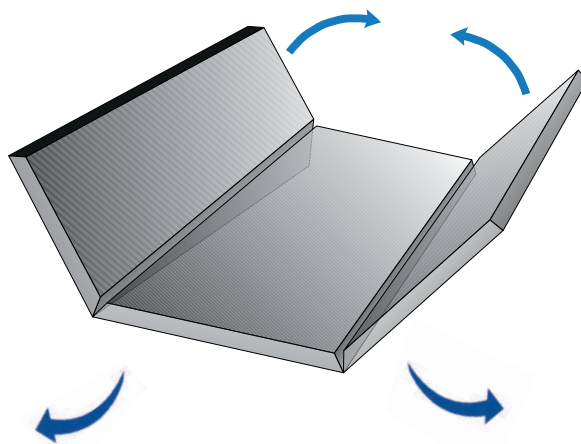
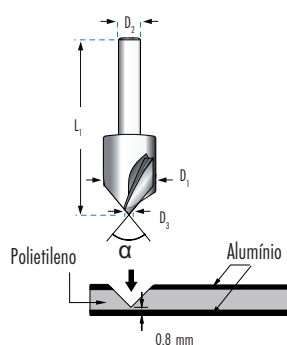

DE PASTILHA SOLDADA

DE METAL DURO INTEGRAL

FFALUC

FFALUC...MDI

	D1 mm	D2 mm	D3 mm	L1 mm	α	€
FFALUC1600	16,00	8	2,5	55	90°	235,54
FFALUC1800	18,00	8	2,5	55	90°	248,06
FFALUC2000	20,00	8	2,5	55	90°	264,49
FFALUC1600-135	16,00	8	2,3	55	135°	235,54
FFALUC1800-135	18,00	8	2,3	55	135°	248,06
FFALUC2000-135	20,00	8	2,3	55	135°	264,49

	D1 mm	D2 mm	D3 mm	L1 mm	L2 mm	α	€
FFALUC1400MDI	14,00	14	2,5	50	14	90°	140,90
FFALUC1600MDI	16,00	16	2,5	50	16	90°	160,35
FFALUC1800MDI	18,00	18	2,5	50	18	90°	184,97
FFALUC1400MDI-135	14,00	14	0,5	50	14	135°	140,90 *
FFALUC1600MDI-135	16,00	16	0,5	50	16	135°	160,35 *
FFALUC1800MDI-135	18,00	18	0,5	50	18	135°	184,97 *

*Até o fim das existências.

BLUE-MASTER®
by *celesa*



FRESAS
COM FURO

FRESA HSSCo DE 3 NAVALHAS PARA FAZER RANHURA COM DENTE CRUZADO

Ref. FF56

HSSCo

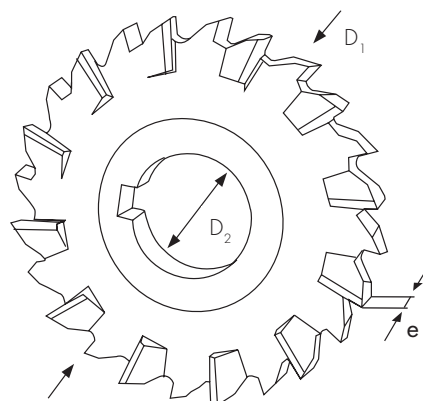
DIN
885A

FF56				
D1 mm	e mm	D2 mm	Z	€
50	4,0	16	12	105,51
50	5,0	16	12	105,51
50	6,0	16	12	122,26
50	8,0	16	12	119,07
50	10,0	16	12	131,11
63	1,6	22	16	225,97
63	2,0	22	16	200,06
63	2,5	22	16	204,24
63	3,0	22	16	209,84
63	4,0	22	12	121,74
63	5,0	22	12	121,74
63	6,0	22	12	125,18
63	8,0	22	12	136,42
63	10,0	22	12	146,79
63	12,0	22	12	156,73
63	14,0	22	12	168,81
63	16,0	22	12	177,69
63	18,0	22	12	212,30
80	1,6	27	20	225,86
80	2,0	27	20	219,38
80	2,5	27	20	223,04
80	3,0	27	20	218,61
80	4,0	27	20	261,53
80	5,0	27	14	165,39
80	6,0	27	14	169,29
80	8,0	27	14	178,66
80	10,0	27	14	191,20
80	12,0	27	14	204,67
80	14,0	27	14	218,86
80	16,0	27	14	223,91
80	18,0	27	14	240,19
80	20,0	27	14	264,10

FF56				
D1 mm	e mm	D2 mm	Z	€
100	1,6	32	24	270,18
100	2,0	32	24	268,72
100	2,5	32	24	268,46
100	3,0	32	24	260,64
100	4,0	32	24	281,00
100	5,0	32	24	297,89
100	6,0	32	16	232,49
100	8,0	32	16	237,39
100	10,0	32	16	246,11
100	12,0	32	16	265,06
100	14,0	32	16	291,82
100	16,0	32	16	306,08
100	18,0	32	16	337,40
100	20,0	32	16	337,40
100	22,0	32	16	378,21
100	25,0	32	16	411,41
125	1,6	32	16	341,68
125	2,0	32	16	328,64
125	2,5	32	16	336,81
125	3,0	32	16	345,01
125	4,0	32	16	369,62
125	5,0	32	16	395,65
125	6,0	32	16	405,42
125	8,0	32	18	366,68
125	10,0	32	18	376,25
125	12,0	32	18	390,51
125	14,0	32	18	424,08
125	16,0	32	18	450,31
125	18,0	32	18	476,31
125	20,0	32	18	506,77
125	22,0	32	18	577,03
125	25,0	32	18	582,62
125	28,0	32	18	636,80

FF56				
D1 mm	e mm	D2 mm	Z	€
160	2,0	40	30	549,95
160	2,5	40	30	529,44
160	3,0	40	30	539,61
160	4,0	40	30	570,19
160	5,0	40	30	603,81
160	6,0	40	30	648,33
160	8,0	40	30	739,99
160	10,0	40	22	607,78
160	12,0	40	22	607,78
160	14,0	40	22	604,80
160	16,0	40	22	661,90
160	18,0	40	22	697,44
160	20,0	40	22	715,92
160	22,0	40	22	786,91
160	25,0	40	22	852,66
160	28,0	40	22	937,29
160	32,0	40	22	1.002,15
200	12,0	40	24	927,11
200	14,0	40	24	936,18
200	16,0	40	24	964,48
200	18,0	40	24	1.011,95
200	20,0	40	24	1.082,29
200	22,0	40	24	1.085,85
200	25,0	40	24	1.259,55
200	28,0	40	24	1.299,37
200	32,0	40	24	1.620,51

FRESA HSSCo DE 3 NAVALHAS PARA FAZER RANHURA COM DENTE RETO



Ref. FF59

HSSCo

**DIN
885B**

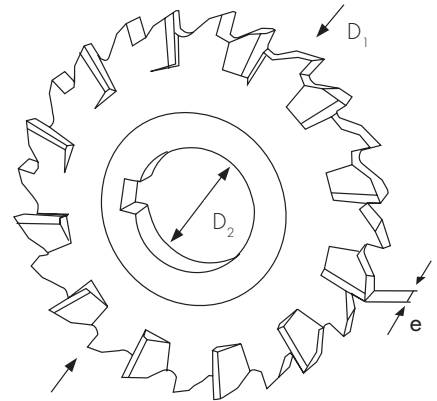
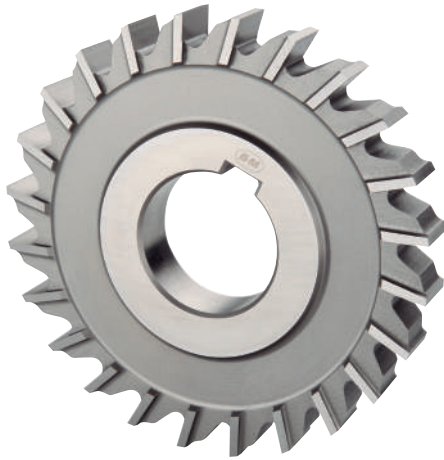

FF59				
D1 mm	e mm	D2 mm	Z	€
50	4	16	16	105,18
50	5	16	16	105,18
50	6	16	16	121,90
50	8	16	16	118,72
50	10	16	16	130,73
63	4	22	18	122,53
63	5	22	18	122,53
63	6	22	18	124,16
63	8	22	18	134,98
63	10	22	18	145,25
63	12	22	18	155,57
63	14	22	18	167,54
63	16	22	18	177,22
63	18	22	18	211,66
80	5	27	20	164,82
80	6	27	20	169,17
80	8	27	20	178,52
80	10	27	20	190,57
80	12	27	20	204,04
80	14	27	20	218,20
80	16	27	20	223,87
80	18	27	20	240,15
80	20	27	20	264,05

FF59				
D1 mm	e mm	D2 mm	Z	€
100	6	32	22	230,13
100	8	32	22	236,66
100	10	32	22	245,32
100	12	32	22	264,20
100	14	32	22	290,88
100	16	32	22	308,17
100	18	32	22	337,33
100	20	32	22	337,33
100	22	32	22	377,07
100	25	32	22	412,48
125	8	32	24	366,46
125	10	32	24	376,02
125	12	32	24	390,28
125	14	32	24	423,84
125	16	32	24	445,60
125	18	32	24	476,16
125	20	32	24	506,63
125	22	32	24	576,88
125	25	32	24	582,47
125	28	32	24	636,60

FF59				
D1 mm	e mm	D2 mm	Z	€
160	10	40	28	607,60
160	12	40	28	607,60
160	14	40	28	604,64
160	16	40	28	661,70
160	18	40	28	697,25
160	20	40	28	715,72
160	22	40	28	786,68
160	25	40	28	852,43
160	28	40	28	937,02
160	32	40	28	1.001,86
200	12	40	30	926,84
200	14	40	30	935,92
200	16	40	30	964,22
200	18	40	30	1.011,67
200	20	40	30	1.081,98
200	22	40	30	1.085,55
200	25	40	30	1.259,21
200	28	40	30	1.299,01
200	32	40	30	1.620,07

FRESA DE MÓDULO PARA ENGRANAGENS
HSS

Ref. 99RFM

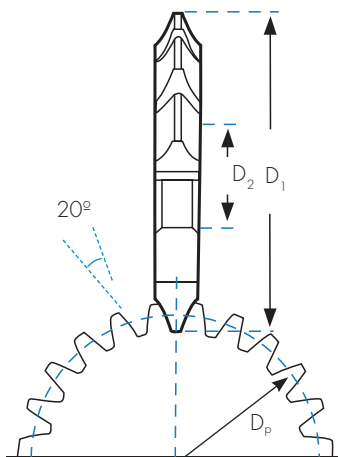
NÚMERO DE FRESA / DENTES A TALHAR

Nº1	Nº2	Nº3	Nº4	Nº5	Nº6	Nº7	Nº8	Set
12-13	14-16	17-20	21-25	26-34	35-54	55-134	135-∞	12-∞

NOTA: o preço depende do módulo, independentemente do nº de dentes a talhar.

$$M = D_p / Z$$

$$M = P \times \pi$$

 M=Modulo
 Dp=Diâmetro primitivo
 Z=Nº de dentes
 P=Passo (Dente+Vale)

99RFM

MÓDULO FRESA	D1 mm	D2 mm	€
0.50	40	16	131,56
0.70	40	16	131,56
0.75	40	16	131,56
0.80	40	16	131,56
1.00	50	16	131,56
1.25	50	16	131,56
1.50	56	22	135,10
1.75	56	22	135,10
2.00	63	22	135,10
2.25	63	22	158,33
2.50	63	22	158,33
2.75	71	27	158,33
3.00	71	27	158,33
3.25	71	27	208,94
3.50	80	27	208,94
3.75	80	27	208,94
4.00	80	27	208,94
4.50	90	32	286,37
5.00	90	32	286,37
6.00	100	32	362,61
7,00	100	32	362,61

FRESAS CILÍNDRICAS, FRONTAIS COM CHAVETA TRANSVERSAL HSSCo

Ref. FF87

HSSCo
DIN 1880



ACABAMENTO

Ref. FF88

HSSCo
DIN 1880

NR

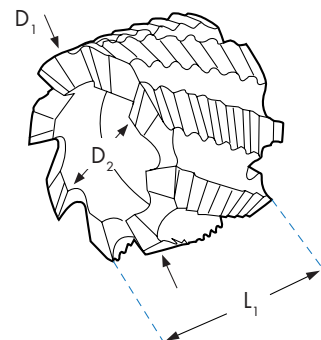
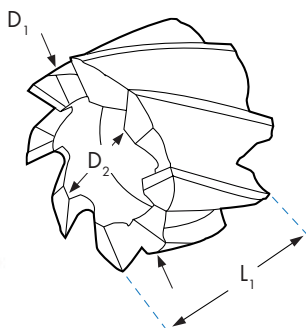
DESBASTE

FF87

D1 mm	D2 mm	L1 mm	Z	€
40	16	32	8	138,75
50	22	36	8	190,90
63	27	40	8	260,85
80	27	45	10	369,21
100	32	50	12	594,39
125	40	56	14	954,54
160	50	63	16	1.705,96

FF88

D1 mm	D2 mm	L1 mm	Z	€
40	16	32	6	200,95
50	22	36	6	249,54
63	27	40	8	330,63
80	27	45	8	485,96
100	32	50	10	801,77
125	40	56	12	1.360,22
160	50	63	14	2.360,18

FRESAS CILÍNDRICAS, FRONTAIS COM CHAVETA TRANSVERSAL HSSCO



Ref. FF89

HSSCo

DIN 884



CILÍNDRICA PARA PLANEAR

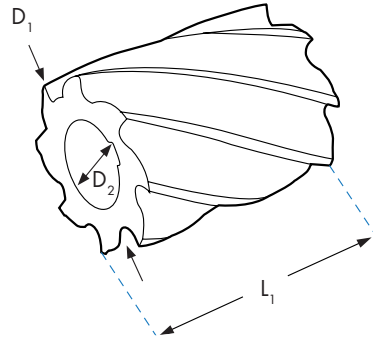
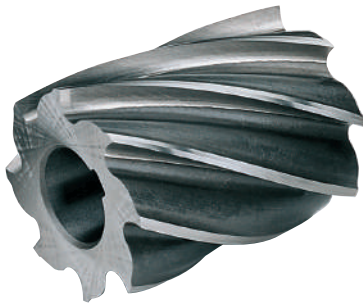

FF89					
D1 mm	D2 mm	L1 mm	Z	€	
50	22	63	8	173,84*	
50	22	80	8	259,14*	
63	27	50	8	228,11*	
63	27	70	8	277,53*	
80	32	63	8	384,48*	
100	40	70	10	598,18*	

*Até o fim das existências.

FRESAS CILÍNDRICAS, FRONTAIS, COM CABO, PARA PLANEAR



Ref. FMF87

HSSCo 8%



ACABAMENTO

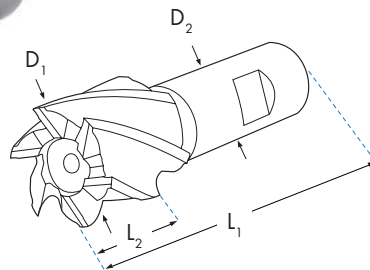
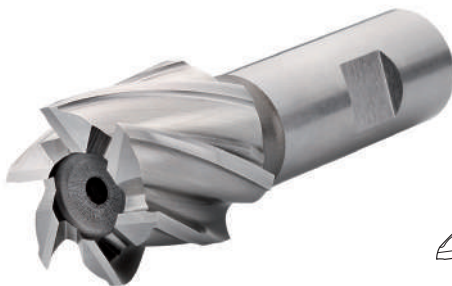

FMF87					
D1 mm	L2 mm	L1 mm	D2 mm	Z	€
30	30	90	20	6	202,26
35	30	90	20	6	232,12
40	32	95	25	8	289,30



Ref. FMF88

HSSCo 8%



DESBASTE

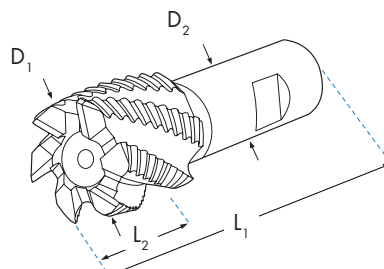

FMF88					
D1 mm	L2 mm	L1 mm	D2 mm	Z	€
30	30	90	20	6	233,82
35	30	90	20	6	299,55
40	32	95	25	8	366,95

FRESAS ANGULARES ISÓSCELES HSSCO

FRESAS

ROSA

Ref. FF77

HSSCo

DIN
847

Ref. FF78

HSSCo

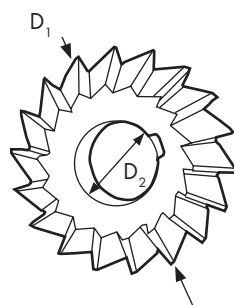
DIN
847

Ref. FF79

HSSCo

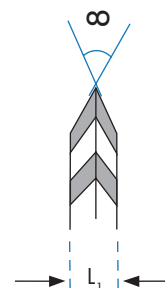
DIN
847

FF77

D1 mm	D2 mm	L1 mm	∞	Z	€
50	16	8	45°	20	185,21
63	22	10	45°	22	220,30
80	27	12	45°	24	307,59
100	32	18	45°	26	384,54

FF78

D1 mm	D2 mm	L1 mm	∞	Z	€
50	16	10	60°	18	188,85
63	22	14	60°	20	224,63
80	27	18	60°	22	313,61
100	32	25	60°	24	392,08

FF79

D1 mm	D2 mm	L1 mm	∞	Z	€
50	16	14	90°	16	188,85
63	22	20	90°	18	224,63
80	27	22	90°	20	313,61
100	32	32	90°	22	392,08

FRESAS ANGULARES FRONTAIS HSSCO

Ref. FF91

HSSCo

DIN
842

Ref. FF90

HSSCo

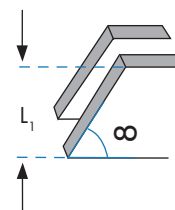
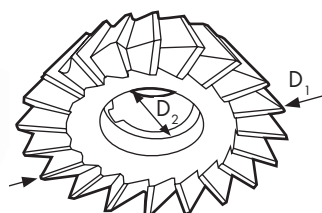
DIN
842

FF91

D1 mm	D2 mm	L1 mm	∞	Z	€
40	10	13	50°	14	146,45
50	13	16	50°	16	180,60
63	16	20	50°	18	228,29
80	22	25	50°	20	328,91
100	27	32	50°	22	477,05
125	32	40	50°	24	787,77
160	40	50	50°	30	1.378,02

FF90

D1 mm	D2 mm	L1 mm	∞	Z	€
40	10	13	60°	14	143,60
50	13	16	60°	16	177,09
63	16	20	60°	18	223,86
80	22	25	60°	20	322,54
100	27	32	60°	22	467,77
125	32	40	60°	24	772,50
160	40	50	60°	30	1.351,27

BLUE-MASTER®
by *celesa*



FRESAS
PARA CHAVES

FERRAMENTAS PARA CHAVEIROS

A GAMA MAIS AMPLA DE FERRAMENTAS PARA SERRALHERIA

DIN
338

PMD



BRILHANTE

FUNDIÇÃO



BC7

BC7B

Ø mm	L1 x L2 mm		€/U.		€/U.
6,00	93 x 57	BC70600	22,79	BC70600B	26,91

Broca DIN 338 com ponta de metal duro para METAIS DUROS. Broca de ALTA DUREZA para a furação de METAIS DUROS em serralheria. Encontre-a na página 51.

DIN
338HSSCo
5%

DOURADO

120
Kg/mm²

BC5

BC5F

BC5B

Ø mm	L1 x L2 mm		€/U.		€		€			
6,00	93 x 57	BC50600	10	4,97	BC50600F	1	5,55	BC50600B	1	6,44

Broca produzida em HSSCo conforme à norma DIN 338 para metais de 120 Kg/mm² de dureza. Broca de ALTA DUREZA para usos gerais em serralheria. Encontre-a na página 50.

DIN
338

PMD



BRILHANTE

70 HRc



BC98

BC98B

Ø mm	L1 x L2 mm		€/U.		€/U.
6,00	93 x 57	BC980600	16,84	BC980600B	20,96

Broca DIN 338 com ponta de metal duro para METAIS MUITO DUROS ou TEMPERADOS. Broca de ALTA DUREZA para a furação de METAIS MUITO DUROS ou TEMPERADOS em serralheria. Encontre-a na página 51.

MD

TOL D1
h7TOL D2
h6

TiAlN

HARDOX
600ALTA
PRODUÇÃO70
HRc

BC85

BC85B

Ø mm	L1 x L2 mm		€/U.		€/U.
6,00	75 x 35	BC850600	82,78	BC850600B	87,93

Broca de metal duro integral para METAIS TEMPERADOS, até dureza 70HRc. Broca de MÁXIMA DUREZA para a furação de METAIS TEMPERADOS em serralheria. Encontre-a na página 70.

BROCA QUADRADA PARA FURAR CANHÕES DE SEGURANÇA

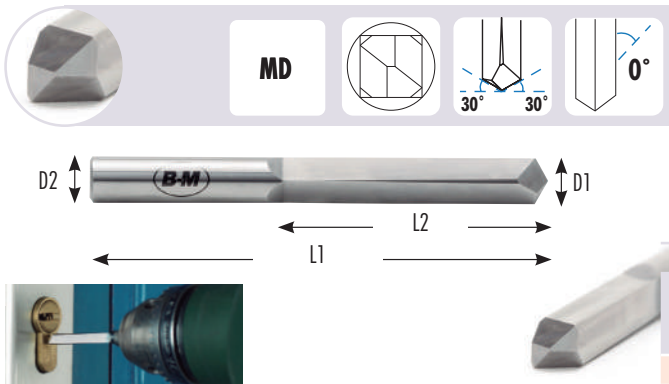

Broca de seção quadrada produzida em metal duro integral para a FURAÇÃO DE CANHÕES E PIVOS ANTI-DRILLING. A BROCA Nº 1 PARA A FURAÇÃO DE CANHÕES DE ALTA DUREZA em serralheria.

* Para furar os canhões com pivos "anti-drilling" trabalhar a 300RPM.

D1 mm	D2 mm	L2 mm	L1 mm	1U.	€	B	€
6	6	33	60	BCC06X60MD	61,93	BCC06X60MDB	67,08

FRESA DE SERRALHEIRO PARA FRESAGEM DE CANHÕES DE SEGURANÇA

TIPO
C

MD



Fresa para o CHAVEIRO, também conhecida como VAMPIRO, produzida em metal duro integral. Geometria hemisférica em comprimentos totais de 60mm a 150mm.

A fresa ideal para a FRESAGEM DE CANHÕES, selecione, da ampla gama de dimensões, a mais adequada para a sua aplicação.

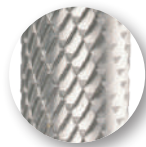
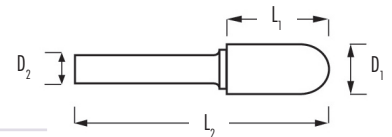

	D1 mm	D2 mm	L1 mm	L2 mm			1U.		B
3 mm. CABO	3.0	3	25.0	60	HSS	Y548TG2	21,84	Y548TG2B	26,04
	3.0	3	25.0	60	Monobloc	C30325-6	37,80	C30325-6B	41,96
6 mm. CABO	6.0	6	25.0	50	Monobloc	C60625-6	41,07	C60625-6B	45,23
	6.0	6	25.0	60	Monobloc	C60625-60-6	46,26	C60625-60-6B	50,42
	6.0	6	25.0	80	Monobloc	C60625-80-6	55,27	C60625-80-6B	59,43
	6.0	6	25.0	100	Monobloc	C60625-100-6	61,66	C60625-100-6B	65,82
	6.0	6	25.0	120	Monobloc	C60625-120-6	92,50	C60625-120-6B	96,66
	6.0	6	25.0	150	Monobloc	C60625-150-6	123,33	C60625-150-6B	127,49



REFERÊNCIA	SETC60625
Nº FRESAS	4
CONTEÚDO	C60625-100-6 / C60625-80-6 C60625-60-6 / C60625-6
P.V.P. €	198,81



FRESA CILÍNDRICA METAL DURO INTEGRAL COM PONTA DE BROCA E LÁBIOS SERRILHADOS

Fresas

NEW

Ref. RCC

MD



INOX



PHENOLIC



Especialmente concebida para a perfuração de cilindros de alta segurança com blindagem.

Perfuração de alta precisão graças à ponta de broca centrada.

2 lábios serrilhados polem o material durante a fresagem para um deslizamento ótimo da ferramenta.

Canais para aliviar as tensões de funcionamento e proporcionar uma excelente evacuação das aparas.

Utilizar com uma potente rebarbadora reta, se possível com controlo de velocidade. 14.000-28.000 r.p.m. para um desempenho ótimo.

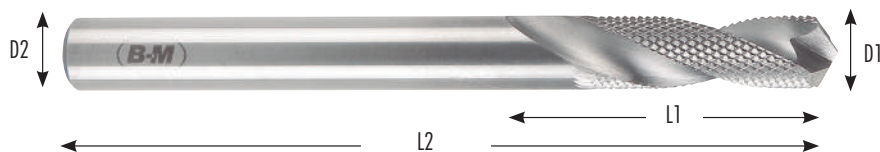

D1 mm	D2 mm	L1 mm	L2 mm		€
5.0	5	20.0	50	RCC0500	38,46
6.0	6	25.0	63	RCC0600	45,74
8.0	8	25.0	63	RCC0800	76,15
10.0	10	25.0	63	RCC1000	96,74

FRESA CILÍNDRICA COM CORTE FRONTAL
**TIPO
A/E**

MD



Fresas rotativas de metal duro forma A / E (Frente cilíndrica) e forma C (hemisférica).

A fresa ideal para a FRESAGEM DE CANHÕES, selecione, da ampla gama de dimensões, a mais adequada para a sua aplicação.

Encontre-as na páginas 335.



6 mm. CABO



D1 mm	L2 mm	D2 mm	L1 mm			1U.		1U.
6.0	25.0	6	50	Monobloc	A60625-6E	36,62	A60625-6EB	40,78



Sob demanda, podemos dotar aos nossos blisters dum sistema anti-furto por eletromagnetismo com um custo adicional do 0,07 € pelo blister, que pode ser colocado em todas as peças ou aleatoriamente.

FRESAS PARA MÁQUINAS DE FAZER CHAVES JMA

FRESAS DE SERRETA O BICONICAS

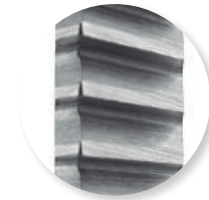

Ref. FLL99: Fresa de serreta 80x5x16 Z110 sem chanfro lateral.

Ref. FLLFP4

Ref. BM	Ref. JMA	TIPOS DE MÁQUINAS	MATERIAL	Ø		mm	mm	Z	mm	FLL
				mm	mm					
FLLFP1 (FLL02)	FP1	OREGON	HSSV	25	10	10	100°	60	0,1	102,56
FLLFP2W	FP2W	VIRGINIA	MD	40	10	6	70°	70	0,1	403,37
FLLFP3 (FLL04)	FP3	KIS, SPRINT	HSSV	50	12	6	90°	80	0,15	124,82
FLLFP4 (FLL06)	FP4	KIS	HSSV	53	12,7	6,35	45/15°	72	0,6	128,73
FLLFP5	FP5	JMA	HSSV	57	12,7	5	90°	80	0,15	160,44
FLLFP6 (FLL09)	FP6	KIS, SPRINT	HSSV	60	12,7	5	84°	140	0,1	124,82
FLLFP1ECCO (FLL11)	FP11/ECCO-009	ECCO, ECCO-PLUS	HSSV	63	16	5	84°	80	1	119,41
FLLFP11W	FP11W	ECCO, ECCO-PLUS	MD	63	16	5	84°	80	1	365,18
FLLFP12	FP12	TUCSON	HSSV	63	16	5	80°	80	1,25	128,73
FLLFP12W	FP12W	TUCSON	MD	63	16	5	80°	80	1,25	394,30
FLLFP13	FP13	DALLAS	HSSV	63	16	5	84°	100	1	160,31
FLLCU14	CU14	ECCO, ECCO-PLUS	HSSV	63	16	5	80°	80	1,25	157,09
FLLFP16 (FLL13)	FP16	PROCODE	HSSV	70	16	5,25	76°	100	1	160,31
FLLFP16W	FP16W	PROCODE	MD	70	16	5,25	76°	100	1	394,30
SLLP01	FP24 DAKOTA = P01	DAKOTA, ERREBI SARATOGA, NEVADA, DENVER, TITAN, VIENNA	HSSV	80	16	5	84°	110	1	103,50
SLLP01/120	FP24 DAKOTA=P01/120		HSSV	80	16	5	84°	120	1	105,47
FLLFP24 (FLL16)	FP24 ERREBI		HSSV	80	16	5	84°	110	1,25	98,46
FLLFP24W	FP24W ERREBI		MD	80	16	5	84°	110	1,25	365,18
FLL99	FP24		HSSV	80	16	5	84°	110	0	113,76

OUTRAS FRESAS DE UTILIZAÇÃO GERAL



Ref. BM	TIPOS DE MÁQUINAS	MATERIAL	Ø		mm	mm	Z	FLL
			mm	mm				
FLL01	FLORA	HSSV	23	10	5	36	118,08	
FLL03	YALE	HSSV	40	8	5	80	128,11	
FLL05	NOVACLAU	HSSV	52	16	5	110	151,27	
FLL07	KIS	HSSV	53	12,7	6	80	168,31	
FLL08	KIS	HSSV	55	12	6	80	168,31	
FLL10	NOVACLAU	HSSV	61	12,7	6,5	140	171,37	
FLL11	NOVACLAU	HSSV	62	16	5	80	168,04	
FLL12	NOVACLAU	HSSV	63	16	5	140	168,04	
FLL14	WALKIN	HSSV	70	15	6,5	150	155,67	
FLL15	LINCE	HSSV	70	13	7	88	173,09	

SERRETA OU BICÓNICAS

FRESAS PARA MÁQUINAS DE FAZER CHAVES JMA
SERRAS CIRCULARES DE CORTE LATERAL

Ref. FLLFP19





Ref. BM	Ref. JMA	TIPOS DE MÁQUINAS	MATERIAL	 mm	 mm	 mm	Z	FLL €
FLL17		JMA-NOVACLAU-WALKIN	HSSV	35	12	3,15	50	116,98
FLL18		JMA-NOVACLAU-WALKIN	HSSV	63	15	1,40	80	143,05
FLLFP7	FP7	ECCO BIT, DETROIT	HSSV	63	16	1,25	80	128,17
FLLFP7W	FP7W	ECCO BIT, DETROIT	MD	63	16	1,25	80	318,51
FLLFP8 (FLL19)	FP8	ECCO BIT, DETROIT	HSSV	63	16	1,4	80	129,59
FLL20		JMA-NOVACLAU-WALKIN	HSSV	70	16	1,40	100	150,07
FLLFP17	FP17	TITAN BIT, SARATOGA, YAKARTA	HSSV	80	16	1,25	100	131,12
FLLFP17W	FP17W	TITAN BIT, SARATOGA, YAKARTA	MD	80	16	1,25	100	334,63
FLLFP18	FP18	ATLANTA, TOPEKA	HSSV	80	22	1,25	100	133,74
FLLFP18W	FP18W	ATLANTA, TOPEKA	MD	80	22	1,25	100	334,63
FLLFP19 (FLL21)	FP19	SARATOGA, YAKARTA, TITAN BIT, DAKOTA	HSSV	80	16	1,4	100	134,24
FLLFP19W	FP19W	SARATOGA, YAKARTA, TITAN BIT, DAKOTA	MD	80	16	1,4	100	313,42
FLLFP20 (FLL22)	FP20	ATLANTA, TOPEKA	HSSV	80	22	1,4	100	134,24
FLLFP21 (FLL24)	FP21/SLLSG2	ATLANTA, TOPEKA, DUPLEX, KANSAS	HSSV	80	22	1,5	100	137,96
FLLFP21W	FP21W	ATLANTA, TOPEKA, DUPLEX, KANSAS	MD	80	22	1,5	100	341,17

SERRAS PARA CHAVES DE PALHETÃO



Ref. FLLFP22W



Ref. BM	Ref. JMA	TIPOS DE MÁQUINAS	MATERIAL	 mm	 mm	 mm	Z	FLL €
FLLFP9	FP9	ECCO BIT	HSSV	63	16	1	80	84,50
FLLFP10	FP10	ECCO FORD, ECCO ABBLOY, PASADENA, NEBRASCA	HSSV	63	16	2,4	80	84,50
FLLFP22	FP22	TITAN BIT, DAKOTA, SARATOGA	HSSV	80	16	1	100	90,14
FLLFP22W	FP22W	TITAN BIT, DAKOTA, SARATOGA	MD	80	16	1	100	308,47
FLLFP23	FP23	DUPLEX, ATLANTA, TOPEKA	HSSV	80	22	1	100	93,39
FLLFP23W	FP23W	DUPLEX, ATLANTA, TOPEKA	MD	80	22	1	100	308,47
FF68801416100CO	-	TITAN, DAKOTA, SARATOGA, YAKARTA	HSSCo	80	16	1,4	100	90,79
FLLFP26 (FLL23)	FP26	G, SENNA, DAKOTA, SARATOGA, YAKARTA	HSSV	80	16	1,5	100	94,68
FLLFP26W	FP26W	G, SENNA, DAKOTA, SARATOGA,	MD	80	16	1,5	100	312,79

FRESAS PARA MÁQUINAS DE FAZER CHAVES JMA

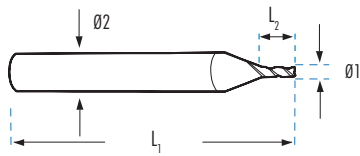
FRESAS PARA CHAVES DE REGATA



Ref. FLLF3



Ref. BM	Ref. JMA	TIPOS DE MÁQUINAS	MATERIAL	Ø1 mm	L1 mm	Ø2 mm	L2 mm	Z	FLL €
FLLF3Z3 (FLL32)	≈ F3	ALBANY ARIZONA COLUMBIA DAKAR DAKAR EXPRESS DAY T-COL DAYTONA X CODE	HSSCo	1,5	45	6	3	3	44,50
FLLF3 (FLL44)	F3		HSSCo	1,5	45	6	3	2	41,65
FLLF3W (FLL45)	F3W		MD	1,5	45	6	3	2	135,41
FLLF33 (FLL53)	F33		HSSCo	2	45	6	4	3	40,21
FLL11Z3 (FLL33)	≈ F11		HSSCo	2,5	45	6	5	3	40,21
FLLF11 (FLL48)	F11		HSSCo	2,5	45	6	5	2	35,99
FLLF11W (FLL49)	F11W		MD	2,5	45	6	5	2	102,50
FLLF17 (FLL34)	F17		HSSCo	3	45	6	6	3	40,21
FLLF8Z3 (FLL35)	≈ F8		HSSCo	4	45	6	6	3	46,80
FLLF8 (FLL46)	F8		HSSCo	4	45	6	7	2	41,65
FLLF8W (FLL47)	F8W		MD	4	45	6	6	2	127,08
FLLF77 (FLL36)	-		HSSCo	5	45	6	7	3	46,80
FLLF78 (FLL37)	-		HSSCo	6	45	6	8	3	46,80
FLLF78W (FLL54)	-		MD	6	45	6	8	3	102,50
FLLF78WZ4 (FLL55)	-		MD	6	45	6	8	4	102,50

FRESAS PARA FAZER O PONTO UNIVERSAIS PARA MAQUINAS TIPO JMA E SILCA

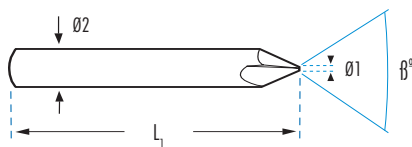

Ref. FLLF1

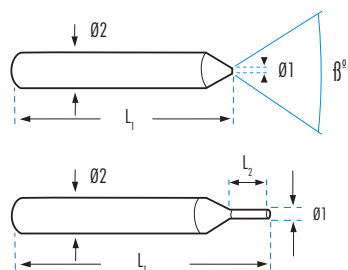

Ref. BM	Ref. JMA	TIPOS DE MÁQUINAS	MATERIAL	β°	Ø1 mm	L1 mm	Ø2 mm	Z	FLL €
FLLF82	-	ALBANY	HSSCo	82°	0,9	45	6	2	27,42
FLLF1 (FLL43)	F1	ARIZONA	HSSCo	90°	0,8	45	6	2	27,42
FLLF1W (FLL42)	F1W	COLUMBIA	MD	90°	0,8	45	6	2	84,92
FLLF5 (FLL52)	F5	DAKAR	HSSCo	90°	0,9	45	6	2	27,42
FLLF5W (FLL42)	F5W	DAKAR EXPRESS	MD	90°	0,9	45	6	2	84,92
FLLF95	-	DAY T-COL	HSSCo	95°	0,9	45	6	2	27,42
FLLF13 (FLL50)	F13	DAYTONA	HSSCo	100°	0,8	45	6	2	27,42
FLLF13W (FLL51)	F13W	X CODE	MD	100°	0,8	45	6	2	79,45
FLLF105	-		HSSCo	105°	0,9	45	6	2	27,42

APALPADORES PARA MÁQUINAS DE FAZER CHAVES JMA
APALPADORES

Ref. FLLP1



Ref. FLLP3

FLL

Ref. BM	Ref. JMA	TIPOS DE MÁQUINAS	MATERIAL	β°	\varnothing_1 mm	L ₁ mm	\varnothing_2 mm	L ₂ mm	€
FLLP1	(PLL38)	P1	HSSV	90°	0,8	45	6	-	22,32
FLLP3	(PLL32)	P3	HSSV	-	1,5	45	6	4	39,48
FLLP5		P5	HSSV	90°	0,9	45	6	-	22,32
FLLP8	(PLL35)	P8	HSSV	-	4	45	6	7	39,48
FLLP11	(PLL33)	P11	HSSV	-	2,5	45	6	4	39,48
FLLP13	(PLL50)	P13	HSSV	100°	0,8	45	6	-	22,32
FLLP17	(PLL34)	P17	HSSV	-	3	45	6	6	39,48
FLLP52	(PLL52)	-	HSSV	90°	0,9	45	6	-	22,32
FLLP77	(PLL36)	-	HSSV	-	5	45	6	7	39,48
FLLP78	(PLL37)	-	HSSV	-	6	45	6	8	39,48

FRESAS KEY LINE

Ref. BM	Ref. JMA	TIPOS DE MÁQUINAS	MATERIAL	β°	\varnothing_1 mm	L ₁ mm	\varnothing_2 mm	L ₂ mm	€
V001	-	KEY LINE	MD	90°	0,4	32	4	-	144,98
V003	-		MD	-	2,5	32	4	5	144,98
V004	-		MD	82°	0,5	32	4	-	144,98
V007	-		MD	100°	0,4	32	4	-	144,98
V012	-		MD	-	1,5	32	4	4	178,26

FRESAS PARA MÁQUINAS DE FAZER CHAVES SILCA

FRESAS DE SERRETA OU BICÓNICAS

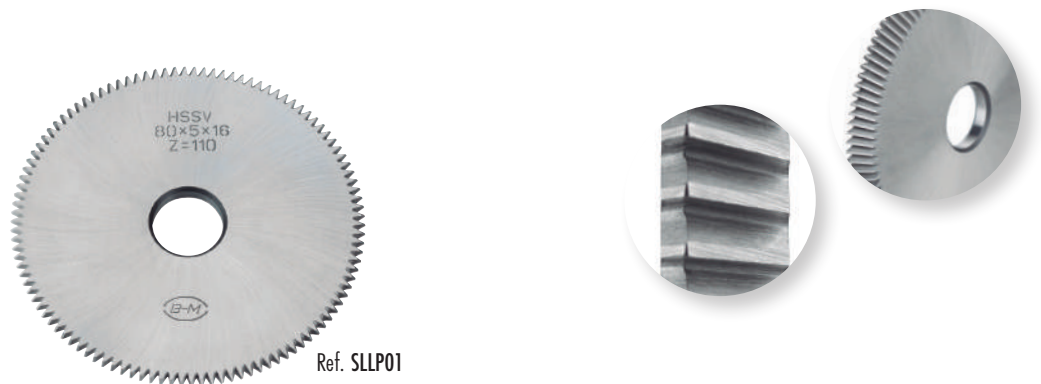

Ref. SLLP01

Ref. BM	Ref. SILCA	TIPOS DE MÁQUINAS	MATERIAL	mm		mm	β°	Z	mm	SLL
				mm	mm					
SLL01F	O1F	FUTURA PRO	MD	60,4	9,52	3,05	40	110	0	160,12
SLLU01	U01	UNOCODE/ULTRACODE	HSSV	60,4	9,52	5,25	80	72	0,5	128,62
SLLU01W	U01W	UNOCODE/ULTRACODE	MD	60,4	9,52	5,25	80	72	0,5	410,92
SLLP21	P21	SILCA DELTA	HSSV	60,4	9,52	5,25	84	72	0,5	116,01
SLLP01	P01	BRAVO/POKER/REKORD BRAVO SUPER/SUPER MASTER	HSSV	80	16	5	84	110	1	103,50
SLLP01/120	P01/120		HSSV	80	16	5	84	120	1	105,47
SLLP01W	P01W		MD	80	16	5	84	110	1	339,09

SERRAS CIRCULARES DE CORTE LATERAL



Ref. SLLSG2

Ref. BM	Ref. SILCA	TIPOS DE MÁQUINAS	MATERIAL	mm		mm	Z	SLL
				mm	mm			
SLLY2KW	Y2KW	DELTA	MD	63	16	1,35	80	310,73
SLLSG19	SG19	DELTA	HSSV	64,6	9,52	1,5	40	87,81
SLLSG19W	SG19W	DELTA	MD	64,6	9,52	1,5	40	295,76
SLLSG18	SG18	DELTA	HSSV	64,6	9,52	2,4	40	87,81
SLLSG18W	SG18W	DELTA	MD	64,6	9,52	2,4	40	295,76
SLLSG6	SG6	LANCER	HSSV	80	22	1,3	100	90,24
SLLSG6W	SG6W	LANCER	MD	80	22	1,3	100	310,73
SLLSG2	SG2	TARGA/TECH3/TECNICA	HSSV	80	22	1,5	100	90,24
SLLSG2W	SG2W	TARGA/TECH3/TECNICA	MD	80	22	1,5	100	310,73
SLLFSC14-CAW	FSCL4-CAW	DELTA	MD	80	22	1,8	100	323,01

FRESAS PARA MÁQUINAS DE FAZER CHAVES SILCA
SERRAS PARA CHAVES DE PALHETÃO

Ref. SLLSG7W

Ref. BM	Ref. SILCA	TIPOS DE MÁQUINAS	MATERIAL	mm			Z	SLL	€
SLLSG14W	SG14W	DELTA	MD	60,4	9,52	1,14	80	248,49	
SLLGB1	GB1	ULTRACODE / UNOCODE	HSSV	60,4	9,52	1,7	66	91,16	
SLL05	05	UNOCODE/ULTRACODE	HSSV	60,4	9,52	1,8	68	91,16	
SLL05W	05W	UNOCODE/ULTRACODE	MD	60,4	9,52	1,8	68	260,78	
SLLCU-15C	CU-15C	OPERA / TARGA	MD	63	16	1,5	80	339,67	
SLLSG17	SG17	DELTA	HSSV	64,6	9,52	1,8	70	91,16	
SLLSG17W	SG17W	DELTA	MD	64,6	9,52	1,8	70	286,44	
SLLSG13	SG13	UNOCODE / DELTA	HSSV	64,6	9,52	2	70	91,16	
SLLSG13W	SG13W	UNOCODE / DELTA	MD	64,6	9,52	2	70	339,67	
SLL06	06	UNOCODE/ULTRACODE	HSSV	64,6	9,52	2,4	70	91,16	
SLL06W	06W	UNOCODE/ULTRACODE	MD	64,6	9,52	2,4	70	276,96	
SLLSG3	SG3	OPERA / TARGA/TECH3	HSSV	80	22	1	100	86,72	
SLLSG3W	SG3W	OPERA / TARGA/TECH3	MD	80	22	1	100	286,44	
SLLSG4	SG4	OPERA / TARGA/TECH3	HSSV	80	22	1,25	100	86,72	
SLLSG4W	SG4W	OPERA / TARGA/TECH3	MD	80	22	1,25	100	286,44	
SLLSG5	SG5	LANCER	HSSV	80	22	1,3	100	86,72	
SLLSG5W	SG5W	LANCER	MD	80	22	1,3	100	286,44	
SLLSG7	SG7	OPERA / TARGA	HSSV	80	22	1,4	100	86,72	
SLLSG7M35	SG7M35	OPERA / TARGA	HSSCo	80	22	1,4	100	111,02	
SLLSG7W	SG7W	LANCER	MD	80	22	1,4	100	286,44	
SLLSG1	SG1	OPERA / TARGA/TECH3	HSSV	80	22	1,5	100	86,72	
SLLSG1W	SG1W	OPERA / TARGA/TECH3	MD	80	22	1,5	100	286,44	
SLLSG8	SG8	TECH3 / TECHNICA	HSSV	80	22	1,75	100	86,72	
SLLSG10	SG10	LANCER	HSSV	80	22	2	100	86,72	
SLLSG10W	SG10W	LANCER/ OPERA / TARGA	MD	80	22	2	100	298,58	
SLLSG11	SG11	SILCA GT40	HSSV	80	22	2,3	100	86,72	
SLLSG12	SG12	TARGA/TECH3/TECNICA/OPERA	HSSV	80	22	2,5	100	86,72	
SLLSG58400	SG58400	DELTA	MD	80	22	4	100	274,28	
SLLPL1	PL1	PRIMA LASER	HSSV	100	22	1	100	149,62	
SLLPL1W	PL1W	PRIMA LASER	MD	100	22	1	100	383,91	
SLLPL1,25	PL1,25	PRIMA LASER	HSSV	100	22	1,25	100	149,62	
SLLPL1,25W	PL1,25W	PRIMA LASER	MD	100	22	1,25	100	366,10	
SLLPL1,5	PL1,5	PRIMA LASER	HSSV	100	22	1,5	100	149,62	
SLLPL1,5W	PL1,5W	PRIMA LASER	MD	100	22	1,5	100	366,10	
SLLPL1,7W	PL1,7W	PRIMA LASER	MD	100	22	1,7	100	377,32	
SLLPL2	PL2.0	PRIMA LASER	HSSV	100	22	2	100	149,62	
SLLPL2W	PL2.0W	PRIMA LASER	MD	100	22	2	100	377,32	

FRESAS PARA MÁQUINAS DE FAZER CHAVES SILCA

FRESAS PARA FAZER O PONTO

MATRIX



Ref. SLLF1W

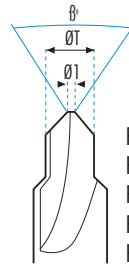
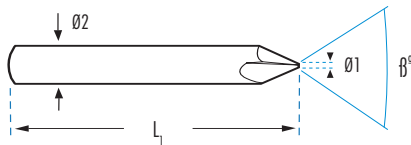

Ref. SLLF19-CAZ1
Ref. SLLF19
Ref. SLLF43
Ref. SLLF21
Ref. SLLF25

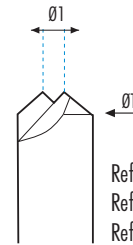

Ref. SLLF12B
Ref. SLLF15
Ref. SLLF37



Ref. BM	Ref. SILCA	UNIV.	TIPOS DE MÁQUINAS	MATERIAL	β°	Ø1 mm	L1 mm	Ø2 mm	Z	SLL
										€
SLLF1Z1	F1	FLLF1	MATRIX	HSSV	90°	0,7	48	6	1	58,00
SLLF1	F1	FLLF1	MATRIX	HSSV	90°	0,7	48	6	2	58,00
SLLF1W	F1W	FLLF1W	MATRIX	MD	90°	0,7	48	6	1	103,69
SLLF4	F4	FLLF1	MATRIX	HSSV	90°	0,4	48	6	1	58,00
SLLF5	F5	FLLF5	MATRIX	HSSV	90°	0,9	48	6	1	58,00
SLLF6	F6	FLLF105	MATRIX	HSSV	106°	1	48	6	1	58,00
SLLF7	F7	FLLF82	MATRIX	HSSV	72°	0,8	48	6	2	58,02
SLLF12A	F12A	FLLF13	MATRIX	HSSV	100°	0,4	48	6	1	58,00
SLLF12B	F12B	FLLF1	MATRIX	HSSV	90°	8 x 1,8*	48	6	2	58,00
SLLF13	F13	FLLF1	MATRIX	HSSV	90°	0,77	48	6	1	58,00
SLLF14	F14	FLLF5	MATRIX	HSSV	90°	0,9	48	6	1	58,00
SLLF15	F15	FLLF1	MATRIX	HSSV	90°	8 x 0,8*	48	6	1	66,47
SLLF19	F19	FLLF1	MATRIX	HSSCo	90°	2,2 x 0,6*	48	6	1	58,02
SLLF19-CAZ1	F19-CA	FLLF1W	MATRIX	MD	90°	2,2 x 0,6*	48	6	1	103,69
SLLF20	F20	FLLF1	MATRIX	HSSV	90°	0,45	48	6	2	58,00
SLLF21	F21	FLLF82	MATRIX	HSSCo	85°	3,2 x 0,8*	48	6	1	66,47
SLLF23	F23	FLLF1	MATRIX	HSSV	90°	1,5	48	6	2	66,47
SLLF24	F24	FLLF13	MATRIX	HSSV	100°	1,3	48	6	1	58,00
SLLF25	F25	FLLF1	MATRIX	HSSV	90°	3,5 x 0,65*	48	6	1	58,00
SLLF26	F26	FLLF82	MATRIX	HSSV	82°	0,8	48	6	1	58,00
SLLF27-CA	F27-CA	-	MATRIX	MD	60°	2,4 x 1,9*	48	6	1	138,52
SLLF28	F28	-	MATRIX	HSSV	76°	0,76	48	6	1	58,00
SLLF29	F29	-	MATRIX	HSSV	76°	1,9 x 0,76*	48	6	1	58,00
SLLF34	F34	-	MATRIX	HSSV	50°	1,5	48	6	1	58,00
SLLF34-CAZ1	F34-CA	-	MATRIX	MD	50°	1,5	48	6	1	103,69
SLLF37	F37	FLLF1	MATRIX	HSSV	90°	6 x 2,1*	48	6	2	66,47
SLLF39	F39	FLLF1	MATRIX	HSSV	90°	0,6	48	6	2	70,45
SLLF42	F42	FLLF13	MATRIX	HSSV	100°	0,7	48	6	1	58,00
SLLF43	F43	FLLF1	MATRIX	HSSCo	90°	1	48	6	1	58,00
SLLF45	F45	-	MATRIX	HSSV	130°	0,56	48	6	1	58,02
SLLF46	F46	FLLF13	MATRIX	HSSV	100°	0,65	48	6	1	58,02
SLLF49	F49	FLLF95	MATRIX	HSSV	95°	0,8	48	6	1	66,47
SLLF50	F50	FLLF13	MATRIX	HSSV	100°	0,5	48	6	1	66,47
SLLF52-CA	F52-CA	-	MATRIX	MD	54°	0,86	48	6	2	58,00
SLLF59	F59	FLLF1	MATRIX	HSSV	90°	0,8	48	6	2	58,00
SLL01D	01D	-	FUTURA PRO	MD	90°	0,4	30	6	2	65,12
SLL02D	02D	-	FUTURA PRO	MD	100°	0,4	30	6	2	65,12

* Ø1 x Ø1

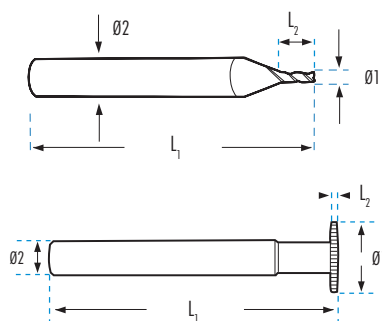
FRESAS PARA MÁQUINAS DE FAZER CHAVES SILCA
FRESAS PARA CHAVES DE REGATA
MATRIX

Ref. SLLF3



*Ref.SLLF62W

SLL

Ref. BM	Ref. SILCA	TIPOS DE MÁQUINAS	MATERIAL	Ø1 mm	L1 mm	Ø2 mm	L2 mm	Z	€
SLLF3	F3	MATRIX	HSSV	1,5	48	6	2	3	58,00
SLLF8	F8	MATRIX	HSSV	4	48	6	13	3	58,00
SLLF11	F11	MATRIX	HSSV	2,5	48	6	7	3	58,00
SLLF22	F22	MATRIX	HSSV	2,5	42	6	6	3	58,00
SLLF30	F30	MATRIX	HSSV	3	48	6	6	3	58,00
SLLF30Z2	F30	MATRIX	HSSV	3	48	6	6	2	68,17
SLLF44	F44	MATRIX	HSSV	2	40	6	6	3	58,00
SLL01L	O1L	FUTURA PRO	MD	2,5	30	6	3	3	65,12
SLL02L	O2L	FUTURA PRO	MD	2	30	6	3	3	65,12

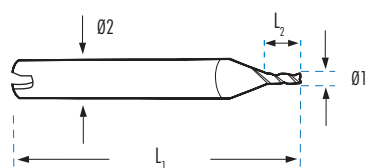
FRESAS PARA CHAVES DE REGATA
QUATTROCODE / TRIAX-E

Ref. SLLW133

SLL

Ref. BM	Ref. SILCA	TIPOS DE MÁQUINAS	MATERIAL	Ø1 mm	L1 mm	Ø2 mm	L2 mm	Z	€
SLLW101	W101	QUATTROCODE / TRIAX-E	MD	2,5	40	6	6	3	132,31
SLLW114	W114	QUATTROCODE / TRIAX-E	MD	2	40	6	6	3	132,33
SLLW117	W117	QUATTROCODE / TRIAX-E	MD	5	48	6	R1	4	107,39
SLLW129	W129	QUATTROCODE / TRIAX-E	MD	3	40	6	6	3	132,31
SLLW131	W131	QUATTROCODE / TRIAX-E	MD	6	40	6	5	3	97,67
SLLW133	W133	QUATTROCODE / TRIAX-E	MD	1,5	40	6	3	3	144,50
SLLW134	W134	QUATTROCODE / TRIAX-E	MD	4	40	6	7	3	132,33
SLLW219	W219	QUATTROCODE / TRIAX-E	MD	1,2	40	6	2	3	132,31
SLLW235	W235	QUATTROCODE / TRIAX-E	MD	1,1	40	6	2	3	132,28
SLLW268	W268	QUATTROCODE / TRIAX-E	MD	1,5	40	6	6	2	132,40

FRESAS PARA MÁQUINAS DE FAZER CHAVES SILCA

FRESAS PARA FAZER O PONTO

QUATTROCODE / TRIAX-E



Ref. SLLW103

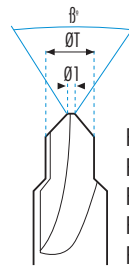
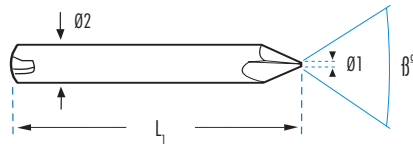

Ref. SLLW115
Ref. SLLW128
Ref. SLLW135
Ref. SLLW145
Ref. SLLW210

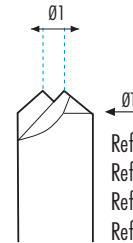

Ref. SLLW111
Ref. SLLW126
Ref. SLLW127
Ref. SLLW139



Ref. BM	Ref. SILCA	TIPOS DE MÁQUINAS	MATERIAL	β°	\varnothing_1 mm	L_1 mm	\varnothing_2 mm	Z	SLL
									€
SLLW102	W102	QUATTROCODE / TRIAX-E	MD	106°	1	40	6	2	92,86
SLLW103	W103/W299	QUATTROCODE / TRIAX-E	MD	90°	0,8	40	6	2	92,86
SLLW104	W104	QUATTROCODE / TRIAX-E	MD	90°	1,2	40	6	2	92,86
SLLW105	W105	QUATTROCODE / TRIAX-E	MD	90°	0,7	40	6	2	92,86
SLLW106	W106	QUATTROCODE / TRIAX-E	MD	90°	0,6	40	6	2	92,86
SLLW107	W107	QUATTROCODE / TRIAX-E	MD	90°	0,9	40	6	2	92,86
SLLW108	W108	QUATTROCODE / TRIAX-E	MD	82°	0,9	40	6	2	92,86
SLLW109	W109	QUATTROCODE / TRIAX-E	MD	110°	0,4	40	6	2	92,86
SLLW110	W110	QUATTROCODE / TRIAX-E	MD	100°	0,6	40	6	2	92,86
SLLW111	W111	QUATTROCODE / TRIAX-E	MD	96°	8x2,75*	40	6	2	104,32
SLLW112	W112	QUATTROCODE / TRIAX-E	MD	60°/0°	1,5	40	6	2	93,46
SLLW113	W113	QUATTROCODE / TRIAX-E	MD	100°	0,76	40	6	2	92,86
SLLW115	W115	QUATTROCODE / TRIAX-E	MD	54°	4x0,86*	40	6	1	124,49
SLLW116	W116	QUATTROCODE / TRIAX-E	MD	90°	1	40	6	2	92,86
SLLW118	W118	QUATTROCODE / TRIAX-E	MD	120°	0,6	40	6	2	92,86
SLLW119	W119	QUATTROCODE / TRIAX-E	MD	85°	0,3	40	6	2	92,86
SLLW121	W121	QUATTROCODE / TRIAX-E	MD	86°	0,05	48	6	3	129,21
SLLW122	W122	QUATTROCODE / TRIAX-E	MD	90°	0,55	40	6	2	111,44
SLLW123	W123	QUATTROCODE / TRIAX-E	MD	76°	0,9	40	6	2	92,86
SLLW124	W124	QUATTROCODE / TRIAX-E	MD	90°	8x0,8*	48	6	3	178,01
SLLW126	W126	QUATTROCODE / TRIAX-E	MD	80°	3,3	48	6	2	111,44
SLLW127	W127	QUATTROCODE / TRIAX-E	MD	80°	2,1	48	6	2	111,44
SLLW128	W128	QUATTROCODE / TRIAX-E	MD	90°	4x0,55*	48	6	1	124,49
SLLW130	W130	QUATTROCODE / TRIAX-E	MD	90°	1,4	40	6	2	125,01
SLLW132	W132	QUATTROCODE / TRIAX-E	MD	60°	2	40	6	1	124,49
SLLW135	W135	QUATTROCODE / TRIAX-E	MD	90°	4x0,55*	40	6	2	124,42
SLLW136	W136	QUATTROCODE / TRIAX-E	MD	76°	2,23	40	6	1	124,49
SLLW138	W138	QUATTROCODE / TRIAX-E	MD	90°	4x0,7*	48	6	2	92,86
SLLW139	W139	QUATTROCODE / TRIAX-E	MD	60°/50°	0,9	40	6	2	138,52
SLLW142	W142	QUATTROCODE / TRIAX-E	MD	100°	1,2	40	6	2	92,86
SLLW145	W145	QUATTROCODE / TRIAX-E	MD	90°	3,2x0,8*	48	6	2	124,42
SLLW210	W210	QUATTROCODE / TRIAX-E	MD	90°	5x1,05*	40	6	3	186,33
SLLW213	W213	QUATTROCODE / TRIAX-E	MD	90°	0,95*	40	6	2	140,21
SLLW221	W221	QUATTROCODE / TRIAX-E	MD	90°	0,5	40	6	2	125,01
SLLW225	W225	QUATTROCODE / TRIAX-E	MD	90°	1	40	6	2	125,01
SLLW238	W238	QUATTROCODE / TRIAX-E	MD	90°	0,8	40	6	2	92,86
SLLW261	W261	QUATTROCODE / TRIAX-E	MD	1,1	3x1,5*	48	6	2	140,21
SLLW255	W255	QUATTROCODE / TRIAX-E	MD	90°	4x0,8*	48	6	2	125,01
SLLW293	W293	QUATTROCODE / TRIAX-E	MD	90°	0,85	40	6	2	125,01
SLLW299	W299	QUATTROCODE / TRIAX-E	MD	90°	3x0,80	40	6	2	100,72

* \varnothing_1 x \varnothing_1

FRESAS PARA MÁQUINAS DE FAZER CHAVES SILCA

FRESAS PARA FAZER O PONTO

QUATTROCODE / TRIAX-E

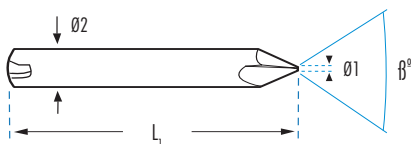

Ref. SLLW103Z1

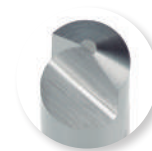

Ref. BM	Ref. SILCA	TIPOS DE MÁQUINAS	MATERIAL	β°	\varnothing_1 mm	L_1 mm	\varnothing_2 mm	Z	€
SLLW102Z1	W102 Z1	QUATTROCODE / TRIAX-E	MD	106°	1	40	6	2	93,46
SLLW103Z1	W103 Z1	QUATTROCODE / TRIAX-E	MD	90°	0,8	40	6	2	93,46
SLLW104Z1	W104 Z1	QUATTROCODE / TRIAX-E	MD	90°	1,2	40	6	2	93,46
SLLW105Z1	W105 Z1	QUATTROCODE / TRIAX-E	MD	90°	0,7	40	6	2	93,46
SLLW106Z1	W106 Z1	QUATTROCODE / TRIAX-E	MD	90°	0,6	40	6	2	93,46
SLLW107Z1	W107 Z1	QUATTROCODE / TRIAX-E	MD	90°	0,9	40	6	2	93,46
SLLW108Z1	W108 Z1	QUATTROCODE / TRIAX-E	MD	82°	0,9	40	6	2	93,46
SLLW109Z1	W109 Z1	QUATTROCODE / TRIAX-E	MD	110°	0,4	40	6	2	93,46
SLLW113Z1	W113 Z1	QUATTROCODE / TRIAX-E	MD	100°	0,76	40	6	2	93,46
SLLW116Z1	W116 Z1	QUATTROCODE / TRIAX-E	MD	90°	1	40	6	2	93,46
SLLW118Z1	W118 Z1	QUATTROCODE / TRIAX-E	MD	120°	0,6	40	6	2	93,46
SLLW119Z1	W119 Z1	QUATTROCODE / TRIAX-E	MD	85°	0,3	40	6	2	93,46
SLLW122Z1	W122 Z1	QUATTROCODE / TRIAX-E	MD	90°	0,55	40	6	2	93,46
SLLW123Z1	W123 Z1	QUATTROCODE / TRIAX-E	MD	76°	0,9	40	6	2	93,46
SLLW146Z1	W146 Z1	QUATTROCODE / TRIAX-E	MD	90°	0,25	40	6	1	93,46

FRESAS PARA FAZER O PONTO

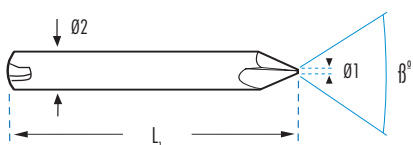

Ref. SLLH103

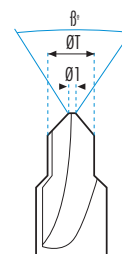
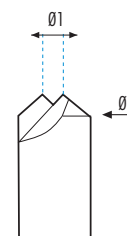

Ref. SLLH115

Ref. SLLH111
Ref. SLLH126
Ref. SLLH127

Ref. BM	Ref. SILCA	UNIV.	TIPOS DE MÁQUINAS	MATERIAL	β°	\varnothing_1 mm	L_1 mm	\varnothing_2 mm	Z	€
SLLH103	H103	FLLF1	QUATTROCODE / TRIAX-E	HSSV	90°	0,8	40	6	2	68,52
SLLH104	H104	FLLF1	QUATTROCODE / TRIAX-E	HSSV	90°	1,2	40	6	2	61,20
SLLH105	H105	FLLF1	QUATTROCODE / TRIAX-E	HSSV	90°	0,7	40	6	2	61,20
SLLH106	H106	FLLF1	QUATTROCODE / TRIAX-E	HSSV	90°	0,6	40	6	2	58,00
SLLH107	H107	FLLF1	QUATTROCODE / TRIAX-E	HSSV	90°	0,9	40	6	2	58,00
SLLH108	H108	FLLF82	QUATTROCODE / TRIAX-E	HSSV	82°	0,9	40	6	2	58,00
SLLH110	H110	FLLF13	QUATTROCODE / TRIAX-E	HSSV	100°	0,6	40	6	2	58,00
SLLH111	H111	FLLF95	QUATTROCODE / TRIAX-E	HSSV	96°	6,4x2,75*	40	6	2	58,00
SLLH112	H112	-	QUATTROCODE / TRIAX-E	HSSV	60°	1,5	40	6	2	58,00
SLLH113	H113	FLLF13	QUATTROCODE / TRIAX-E	HSSV	100°	0,76	40	6	2	58,00
SLLH115	H115	-	QUATTROCODE / TRIAX-E	HSSV	54°	4x0,86*	40	6	1	58,00
SLLH116	H116	FLLF1	QUATTROCODE / TRIAX-E	HSSV	90°	1	40	6	2	76,56
SLLH118	H118	-	QUATTROCODE / TRIAX-E	HSSV	120°	0,6	40	6	1	58,00
SLLH119	H119	FLLF82	QUATTROCODE / TRIAX-E	HSSV	85°	0,3	40	6	2	58,00
SLLH122	H122	FLLF1	QUATTROCODE / TRIAX-E	HSSV	90°	0,55	40	6	2	58,00
SLLH126	H126	FLLF85	QUATTROCODE / TRIAX-E	HSSV	80°	3,3*	48	6	2	86,57
SLLH127	H127	FLLF85	QUATTROCODE / TRIAX-E	HSSV	80°	2,1*	48	6	2	86,57
SLLH128	H128	FLLF1	QUATTROCODE / TRIAX-E	HSSV	90°	0,75	48	6	2	58,00

* $\varnothing_1 \times \varnothing_1$

FRESAS PARA MÁQUINAS DE FAZER CHAVES SILCA

FRESAS PARA CHAVES DE REGATA

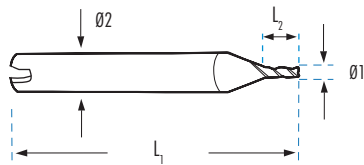

Ref. SLLH101



Ref. BM	Ref. SILCA	TIPOS DE MÁQUINAS	MATERIAL	Ø1 mm	L1 mm	Ø2 mm	L2 mm	Z	SLL €
SLLH101	H101	QUATTROCODE / TRIAX-E	HSSV	2,5	40	6	6	3	68,13
SLLH114	H114	QUATTROCODE / TRIAX-E	HSSV	2	40	6	6	3	58,00
SLLH117	H117	QUATTROCODE / TRIAX-E	HSSV	5	48	6	R1	4	70,37
SLLH129	H129	QUATTROCODE / TRIAX-E	HSSV	3	40	6	6	3	58,00
SLLH131	H131	QUATTROCODE / TRIAX-E	HSSV	6	40	6	5	3	76,56

APALPADORES

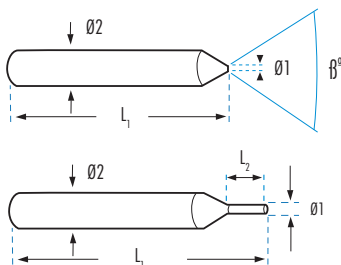

Ref. SLLT1



Ref. SLLT3

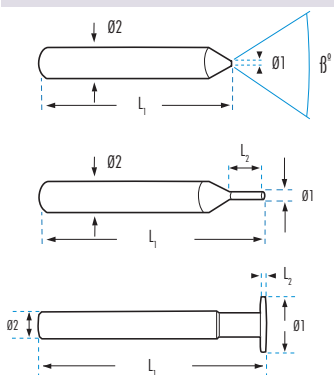

Ref. BM	Ref. SILCA	TIPOS DE MÁQUINAS	Ref. FRESA	MATERIAL	β°	Ø1 mm	L1 mm	Ø2 mm	L2 mm	ØT mm	SLL €
SLLT1	T1	MATRIX	F1	HSSV	90°	0,7	48	6	-	-	40,50
SLLT2	T2	MATRIX	F2	HSSV	88°	1,6	48	6	-	-	45,61
SLLT3	T3	MATRIX	F3	HSSV	-	1,5	48	6	3	-	45,61
SLLT4	T4	MATRIX	F4	HSSV	90°	0,4	48	6	-	-	45,61
SLLT5	T5	MATRIX	F5	HSSV	90°	0,9	48	6	-	-	45,61
SLLT6	T6	MATRIX	F6	HSSV	106°	1	48	6	15	-	45,61
SLLT7	T7	MATRIX	F7	HSSV	72°	0,8	48	6	2	-	45,61
SLLT8	T8	MATRIX	F8	HSSV	-	4	48	6	12	-	45,61
SLLT11	T11	MATRIX	F11	HSSV	-	2,5	48	6	6	-	45,61
SLLT12A	T12A	MATRIX	F12A	HSSV	100°	0,4	48	6	-	-	45,61
SLLT12B	T12B	MATRIX	F12B	HSSV	90°	2,8	48	6	-	-	45,61
SLLT13	T13	MATRIX	F13	HSSV	90°	0,77	48	6	-	-	45,61
SLLT14	T14	MATRIX	F14	HSSV	90°	0,9	48	6	-	-	45,61
SLLT15	T15	MATRIX	F15	HSSV	90°	0,8	48	6	-	-	45,61
SLLT19	T19	MATRIX	F19	HSSV	90°	2,2 x 0,6*	48	6	-	-	45,61
SLLT20	T20	MATRIX	F20	HSSV	90°	0,45	48	6	-	-	45,61
SLLT21	T21	MATRIX	F21	HSSV	85°	3,2 x 0,8*	48	6	-	-	45,61
SLLT22	T22	MATRIX	F22	HSSV	-	2,5	42	6	6	-	45,61
SLLT23	T23	MATRIX	F23	HSSV	90°	1,5	48	6	5	-	45,61

FRESAS PARA MÁQUINAS DE FAZER CHAVES SILCA
APALPADORES

*Ref. SLLT62W



Ref. SLLT1



Ref. SLLT3



Ref. BM	Ref. SILCA	TIPOS DE MÁQUINAS	Ref. FRESA	MATERIAL	β°	\varnothing_1 mm	L_1 mm	\varnothing_2 mm	L_2 mm	\varnothing_T mm	SLL €
SLLT24	T24	MATRIX	F24	HSSV	100°	1,3	48	6	-	-	45,61
SLLT25	T25	MATRIX	F25	HSSV	90°	3,5 x 0,65*	48	6	-	-	45,61
SLLT26	T26	MATRIX	F26	HSSV	82°	0,8	48	6	-	-	45,61
SLLT27	T27	MATRIX	F27	HSSV	60°	1,28	48	6	-	-	51,49
SLLT28	T28	MATRIX	F28	HSSV	76°	0,76	48	6	-	-	45,61
SLLT29	T29	MATRIX	F29	HSSV	76°	1,9	48	6	-	-	45,61
SLLT30	T30	MATRIX	F30	HSSV	-	3	48	6	10	-	45,61
SLLT30-45	T30-45	MATRIX	F30	HSSV	-	3	45	6	10	-	45,61
SLLT33	T33	MATRIX	F33	HSSV	48°	1,4	48	6	-	-	68,01
SLLT34	T34	MATRIX	F34	HSSV	50°	1,5	48	6	-	-	45,61
SLLT37	T37	MATRIX	F37	HSSV	90°	2,1	48	6	-	-	45,61
SLLT39	T39	MATRIX	F39	HSSV	90°	0,6	48	6	-	-	45,61
SLLT40	T40	MATRIX	F40	HSSV	108°	0,4	48	6	-	-	45,61
SLLT42	T42	MATRIX	F42	HSSV	100°	0,7	48	6	-	-	45,61
SLLT43	T43	MATRIX	F43	HSSV	90°	1	48	6	-	-	45,61
SLLT44	T44	MATRIX	F44	HSSV	-	2	48	6	8	-	45,61
SLLT44-45	T44-45	MATRIX	F44	HSSV	-	2	45	6	8	-	45,61
SLLT46	T46	MATRIX	F46	HSSV	100°	0,65	48	6	-	-	45,61
SLLT49	T49	MATRIX	F49	HSSV	95°	0,8	48	6	-	-	45,61
SLLT50	T50	MATRIX	F50	HSSV	100°	0,5	48	6	-	-	45,61
SLLT52	T52	MATRIX	F52	HSSV	54°	0,86	48	6	6	2	45,61
SLLT54	T54	MATRIX	F54	HSSV	-	4	40	6	6,5	-	58,00
SLLT55	T55	MATRIX	F55	HSSV	100°	1	48	6	4	-	45,61
SLLT59	T59	MATRIX	F59	HSSV	90°	0,8	48	6	-	-	45,61
SLLT62W*	T62W	MATRIX	F62W	MD	-	11,8	48	6	1	-	91,07
SLLT63	T63	MATRIX	F63	HSSV	78°	0,5	48	6	4	3	45,61
SLLT65	T65	MATRIX	F65	HSSV	90°	1,05	48	6	5	3	45,61
SLLT101	T101	MATRIX	F101	HSSV	-	2,5	40	6	6	-	45,61
SLLT129	T129	MATRIX	F129	HSSV	-	3	40	6	10	-	45,61
SLLU101	U101	QUATTROCODE	F101	MD	-	1,2	48	6	3	-	58,00
SLLU101/H	U101/H	QUATTROCODE / TRIAX-E	F101	MD	-	1,2	48	6	3	-	39,41
SLLU102/65	U102/65	QUATTROCODE / TRIAX-E	F102	MD	30°	0,2	48	6	9	2,6	61,95
SLLU102TT	U102TT	QUATTROCODE / TRIAX-E	F102	MD	30°	0,2	26	4	6	2	61,95
SLLU103	U103	QUATTROCODE / TRIAX-E	F103	MD	-	1	48	6	3	-	58,00
SLLU103/H	U103/H	QUATTROCODE / TRIAX-E	F103	MD	-	1	48	6	3	-	39,41
SLLU103-TT	U103-TT	QUATTROCODE / TRIAX-E	F103	MD	-	1	21	4	3	-	58,00
SLLU103-TT/H	U103-TT/H	QUATTROCODE / TRIAX-E	F103	MD	-	1	21	4	3	-	39,41
SLLU111	U111	SILCA VIPER	F111	MD	-	1	40	6	2,2	-	58,00
SLLU111/H	U111/H	SILCA VIPER	F111	MD	-	1	40	6	2,2	-	39,41
SLLB3304	B3304	KEYLINE BIANCHI 994 LASER	F3304	MD	-	1	33	6	6	-	58,02
SLLB3310	B3310	KEYLINE BIANCHI 994 LASER	F3310	MD	-	1	30	6	2,6	-	58,02
SLLB3310M2	B3310	KEYLINE BIANCHI 994 LASER	F3310	HSSV	-	1	30	6	2,6	-	42,98