

**BLUE-MASTER®**  
by *celesa*





FRAISES

FRAISES SÉRIE COURTE, 2 DENTS DIN 327 ET DIN 844

Fraises

Rose

2Z

WELDON

34 HRc

INOX

Al

TOL D2  
h6

Réf. FFAL



SÉRIE COURTE

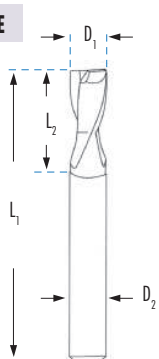



Consulter dimensions DIN 844 dans les pages suivantes



DIN 327	MATÉRIEL				FF01	FF02	FF60	FT02	FF92	FP05	FT12	FP08	FT01	DIN 844	FFAL										
	FINITION															HSS	HSSCo 8%	HSSCo 8%	HSSCo 8%	HSSCo 8%	ASP 60	ASP 60	ASP 60	ASP 60	HSSCo 8%
	QUALITÉ															BRILLANT	BRILLANT	TiAIN	TiAISIN	BRILLANT	BRILLANT	TiAISIN	BRILLANT	TiAISIN	BRILLANT
D1 mm	L1 mm	L2 mm	D2 mm	TOL e8	TOL e8	TOL e8	TOL e8	TOL h10	TOL e8	TOL e8	TOL h10	TOL h10	TOL e8	€											
1,00	47	2,5	6							24,80	30,01	36,16	43,15												
2,00	48	4,0	6	11,27	13,53	19,86	22,88	21,21		20,92	26,69	31,92	39,24		17,28										
2,50	49	5,0	6		13,53	19,86	22,88	22,26							17,62										
3,00	49	5,0	6	11,27	13,53	19,86	22,88	21,34		20,92	26,69	31,92	39,24		17,23										
3,50	50	6,0	6		14,40	20,89	27,33	22,26							18,28										
4,00	51	7,0	6	11,06	13,53	19,87	27,32	21,34		19,02	26,63	31,92	39,24		17,75										
4,50	52	8,0	6	11,06*	14,55	22,06	30,31	22,26							19,41										
5,00	52	8,0	6	11,06	13,53	19,87	27,32	21,34		19,02	26,63	31,92	39,24		17,75										
5,50	52	8,0	6		14,39	22,63	31,09	22,26							21,73										
6,00	52	8,0	6	11,06	13,53	19,87	27,32	21,34		19,02	26,63	31,92	39,24		19,24										
6,50	60	10,0	10	16,50*	19,26	29,60	37,10								28,42										
7,00	60	10,0	10	16,50	18,68	28,98	38,14	27,03		28,70	37,02	42,23	55,85		25,85										
7,50	61	11,0	10		19,36	30,79	37,89								30,30										
8,00	61	11,0	10	13,42	17,50	27,40	33,71	27,04		28,70	37,02	42,23	55,85		23,39										
8,50	61	11,0	10		19,40	34,27	42,14								31,94										
9,00	61	11,0	10	17,15	17,94	32,38	39,83	26,99		30,68	39,97	42,23	57,54		28,96										
9,50	63	13,0	10		19,19	33,52	41,22																		
10,00	63	13,0	10	14,11	17,38	28,34	34,87	27,12		27,77	37,53	42,23	57,54		25,29										
10,50	70	13,0	12		26,32	41,60	51,17																		
11,00	70	13,0	12		25,86	38,62	47,50	35,38							34,90										
12,00	73	16,0	12	18,43	23,26	35,35	43,49	35,36		35,43	47,48	57,51	73,11		31,71										
13,00	73	16,0	12		30,54	46,42	58,56	39,97							45,20										
14,00	73	16,0	12	26,23	30,54	46,42	58,56	39,97		43,19	55,79	64,99	80,90		43,73										
15,00	73	16,0	12		36,08	49,88	66,36	44,66							48,72										
16,00	79	19,0	16	27,40	33,60	49,49	60,89	45,95		54,06	67,38	75,98	94,40		47,47										
17,00	79	19,0	16		43,57	63,18	77,74								66,03										
18,00	79	19,0	16	35,87	43,57	63,25	77,82	56,64		68,45	80,76	96,32	145,50		59,30										
19,00	79	19,0	16		56,99	76,61	94,24								79,97										
20,00	88	22,0	16		61,01	85,04	104,64																		
20,00	88	22,0	20	42,05	52,87	73,70	90,69	65,19		80,65	101,50	112,29	148,61		68,54										
22,00	88	22,0	20	57,68	66,27	97,68	120,16	73,41		102,71	135,60	133,34	170,66		95,43										
24,00	102	26,0	25	72,38	77,24	121,27	149,20	98,05							143,38										
25,00	102	26,0	25	72,39	75,25	113,97	143,07	97,23		137,14	163,38	174,81*	215,97*		121,44										
26,00	102	26,0	25		86,02	158,79	195,34								190,72										
28,00	102	26,0	25	90,70	102,94	159,21	195,43								147,77										
30,00	102	26,0	25	104,35	104,42	167,06	205,52	156,50							170,05										
32,00	112	32,0	32	108,21	132,40	170,12	209,30								180,13										
36,00	112	32,0	32	139,32	177,11	218,54	268,86																		
40,00	130	38,0	32	169,38	217,48	270,20	332,42																		

\*Jusqu'à fin des stocks

**FRAISES SÉRIE LONGUE, 2 DENTS DIN 327 ET DIN 844/L**

**2 Z**  **30° N**  **WELDON**  **34 HRc** **INOX** **Al** **TOL D2 h6** Réf. FFLAL  **45° W**

**SÉRIE LONGUE**



DIN 327/L				MATÉRIEL	FF06	FF67	FT06	FF15	FP21	DIN 844/L			FFLAL
FINITION					HSSCo 8%	HSSCo 8%	HSSCo 8%	HSSCo 8%	ASP 60				HSSCo 8%
QUALITÉ					BRILLANT	TiAlN	TiAlSiN	BRILLANT	BRILLANT				BRILLANT
					★★	★★★	★★★★	★★					Al
					TOL e8	TOL e8	TOL e8	TOL h10	TOL h10				TOL e8
D1 mm	L1 mm	L2 mm	D2 mm	€	€	€	€	€	€	L1 mm	L2 mm	D2 mm	€
2,00	54	7	6	15,74*	24,84*	28,94*	31,96	37,49*	54	10	6	26,03	
2,50	56	8	6	15,74*	24,84*	28,94*	32,00		56	12	6		
3,00	56	8	6	15,96	24,89	29,03	32,00	38,65*	56	12	6	26,16	
3,50	59	10	6	17,87	29,56	34,50			59	15	6		
4,00	63	11	6	15,81	24,89	29,03	32,00	38,65	63	19	6	26,33	
4,50	63	11	6	17,62	25,42	29,64			63	19	6		
5,00	68	13	6	15,81	24,89	29,03	33,88	40,90*	68	24	6	26,45	
5,50	68	13	6	17,87	29,56	34,50			68	24	6		
6,00	68	13	6	15,81	24,89	29,03	30,61	36,95*	68	24	6	27,46	
6,50	80	16	10	29,65	48,52	55,79			68	24	6		
7,00	80	16	10	26,10	36,44	42,50	38,62	46,17*	80	30	10		
7,50	88	19	10						80	30	10		
8,00	88	19	10	22,97	33,28	38,82	38,62	46,60*	88	38	10	37,52	
8,50	88	19	10	35,16	47,85	55,80			88	38	10		
9,00	88	19	10	30,91	42,16	49,12	42,36		88	38	10	39,57	
10,00	95	22	10	25,30	38,54	44,94	42,19	51,15*	95	45	10	37,52	
11,00	102	22	12	39,90	53,81	62,76	56,18		102	45	12	52,58*	
12,00	110	26	12	36,39	50,90	59,36	55,10	66,21*	110	53	12	44,46	
13,00	110	26	12						110	53	12		
14,00	110	26	12	44,57	62,21	72,55	73,10	82,98	110	53	12	50,89	
15,00	123	32	16						110	53	12		
16,00	123	32	16	53,92	76,78	89,54	83,21	99,03	123	63	16	62,75	
17,00	123	32	16						123	63	16		
18,00	123	32	16	62,82	90,12	105,06	100,00	118,99	123	63	16	72,95	
20,00	141	38	20	72,23	98,85	115,27	108,42	129,01	141	75	20	84,22	
22,00	141	38	20	99,03	134,15	156,42	134,39	159,94	141	75	20		
24,00	166	45	25	128,56	170,65	196,21	180,79		166	90	25		
25,00	166	45	25	130,61	180,50	210,49	165,29	196,70	166	90	25		
26,00	166	45	25	169,24	200,96	231,06			166	90	25		
28,00	166	45	25	172,15	219,75	256,27			166	90	25		
30,00	166	45	25	191,38	236,56	275,85	246,22		166	90	25		
32,00	186	53	32	264,76	308,38	359,59	320,82		186	106	32		
36,00	186	53	32	299,54	350,63	408,87			186	106	32		
40,00	196	63	32	392,52	473,72	552,43			196	125	32		

**FRAISES SÉRIE COURTE, 3 DENTS DIN 844 ET DIN 327**

Fraises

Rose

3Z

TOL D<sub>2</sub>  
h6

## SÉRIE COURTE

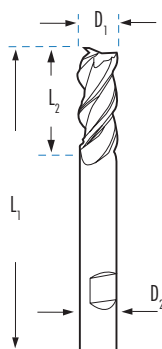

DIN 844				MATÉRIEL	FF63	FF75	FT63	FF73	FF76	FT73	FP06	FT03
D <sub>1</sub> mm	L <sub>1</sub> mm	L <sub>2</sub> mm	D <sub>2</sub> mm		HSSCo 8%	HSSCo 8%	HSSCo 8%	HSSCo 8%	HSSCo 8%	HSSCo 8%	ASP 60	ASP 60
					BRILLANT	TiAIN	TiAlSiN	BRILLANT	TiAIN	TiAlSiN	BRILLANT	TiAlSiN
					★★	★★★	★★★★	★★	★★★	★★★★	Premium Quality	Premium Quality
					TOL k10	TOL k10	TOL k10	NR	NR	NR	TOL e8	TOL e8
				€	€	€	€	€	€	€	€	€
1,00	49	3	6								26,66	33,20
2,00	51	7	6	15,70	24,70	28,80					21,65	32,44
2,50	52	8	6	15,70	24,70	28,80						
3,00	52	8	6	15,70	24,70	28,80					21,65	32,44
3,50	55	11	6	16,17	25,17	29,49						
4,00	55	11	6	15,69	24,70	28,80					21,65	32,44
4,50	57	13	6	17,28	26,10	30,44						
5,00	57	13	6	15,69	24,81	28,94					21,65	32,44
5,50	57	13	6	21,34	33,96	39,59						
6,00	57	13	6	14,55	27,08	30,82	44,79	54,08	62,18	21,65	32,44	
6,50	66	16	10	29,62	45,42	52,23						
7,00	66	16	10	23,08	33,35	39,07	52,96*	64,55	74,22	29,16	39,53	
7,50	69	19	10	29,84*	45,90*	52,78*						
8,00	69	19	10	20,61	30,78	35,90	45,88	53,45	62,34	29,16	39,53	
8,50	69	19	10	31,46	47,40	54,50						
9,00	69	19	10	25,74	36,92	43,05	54,45*	63,92*				
9,50	72	22	10		49,81*	57,27*						
10,00	72	22	10	20,96	33,40	38,96	46,14	56,82	66,24	30,91	40,88	
11,00	79	22	12	29,17	46,33	60,65	66,64*	76,75*				
12,00	83	26	12	27,37	39,88	46,51	55,55	65,40	76,25	39,87	51,70	
13,00	83	26	12	35,84	53,30	70,53		84,52*				
14,00	83	26	12	33,68	52,31	61,01	63,39	74,58	86,98	51,67	62,96	
15,00	83	26	12	44,11	63,64	73,18	80,23	87,83	96,80			
16,00	92	32	16	40,15	58,38	68,08	81,49	92,67	108,10	60,76	72,48	
17,00	92	32	16	51,32	71,59	103,62						
18,00	92	32	16	46,44	71,28	83,12	84,07	102,02	118,97	74,77	88,65	
19,00	92	31	16	59,61	83,32	119,24						
20,00	104	38	20	56,20	80,35	93,70	102,59	120,00	139,93	88,92	106,12	
22,00	104	38	20	76,63	121,30	139,48				118,70*	151,83*	
25,00	121	45	25	95,41	126,09	184,68	155,38	177,56	207,06	149,01*	171,20*	
28,00	121	45	25	109,47	167,84	206,49						
30,00	121	45	25	114,47	177,42	242,53	193,22	227,98	265,88			
32,00	133	53	32	171,33	227,65	261,75						

**FRAISES FINITION SÉRIE LONGUE, 3 DENTS DIN 844/L**

**3 Z**



**SÉRIE LONGUE**

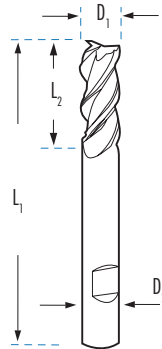

DIN 844/L		MATÉRIEL		FF83	FF86	FT83
		FINITION		HSSCo 8%	HSSCo 8%	HSSCo 8%
		QUALITÉ		BRILLANT	TiAlN	TiAlSiN
				★★	★★★	★★★★
D1 mm	L1 mm	L2 mm	D2 mm	€	€	€
1,00	52	7	6			
2,00	54	10	6	21,70	30,97	36,11
2,50	56	12	6			
3,00	56	12	6	21,15	30,88	36,00
3,50	59	15	6	23,67	33,10	38,62
4,00	63	19	6	21,15	30,88	36,00
4,50	63	19	6	23,67	33,10	38,62
5,00	68	24	6	21,15	30,88	36,00
5,50	68	24	6	23,11	33,10	38,62
6,00	68	24	6	23,15	32,29	37,66
6,50	68	24	6			
7,00	80	30	10	32,10	43,23	50,41
7,50	80	30	10			
8,00	88	38	10	29,36	39,00	45,46
8,50	88	38	10			
9,00	88	38	10	32,53	46,26	53,96
9,50	88	38	10			
10,00	95	45	10	29,53	42,88	50,01
11,00	102	45	12	43,02*	58,41*	68,11*
12,00	110	53	12	37,59	52,28	60,98
13,00	110	53	12			
14,00	110	53	12	47,78	63,93	74,56
15,00	110	53	12			
16,00	123	63	16	55,14	77,05	89,87
17,00	123	63	16			
18,00	123	63	16	65,86	91,09	106,23
19,00	123	63	16			
20,00	141	75	20	77,32	104,22	121,52
22,00	141	75	20	98,90	134,39	156,72
25,00	166	90	25	144,15	177,53	207,04
28,00	166	90	25	160,48	212,60	247,94
30,00	166	90	25	178,67	227,10	264,84
32,00	186	106	32	212,59	255,76	298,27

**FRAISES FINITION SÉRIE COURTE ET LONGUE, MULTIDENTS DIN 844 ET DIN 844/L**

Fraises

Rose

**4-6 Z**

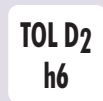
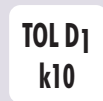
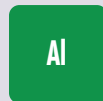

**SÉRIE COURTE**

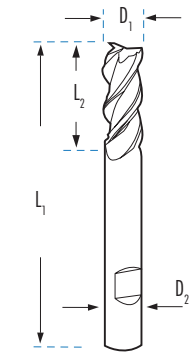

**SÉRIE LONGUE**







DIN 844		MATÉRIEL		FINITION		QUALITÉ			
D1 mm	L1 mm	L2 mm	D2 mm	Z	FF18	FF20	FT18	FP07	FT09
					HSSCo 8% BRILLANT ★★	HSSCo 8% TiAlN ★★★	HSSCo 8% TiAlSiN ★★★★	ASP 60 BRILLANT Premium Quality	ASP 60 TiAlSiN Premium Quality
					€	€	€	€	€
1,00	49	3	6	4				29,56	35,09
2,00	51	7	6	4	15,75	22,78	26,97	21,60	29,60
2,50	52	8	6	4	15,75	22,78	26,97		
3,00	52	8	6	4	15,75	22,78	26,41	21,60	29,60
3,50	55	11	6	4	16,21	23,20	28,04		
4,00	55	11	6	4	15,75	22,78	25,85	21,60	29,60
4,50	57	13	6	4	16,39	24,04	29,04		
5,00	57	13	6	4	15,75	22,78	25,85	21,60	29,60
5,50	57	13	6	4	17,17	31,23	37,71		
6,00	57	13	6	4	16,43	22,76	26,38	21,60	29,60
6,50	66	16	10	4	25,12	35,35	39,25		
7,00	66	16	10	4	22,76	33,36	37,04	29,36	42,26
7,50	69	16	10	4	29,74	39,72	44,12		
8,00	69	19	10	4	20,32	30,91	34,33	29,23	41,83
8,50	69	19	10	4	31,01	42,00	48,98		
9,00	69	19	10	4	22,60	36,96	43,11	34,53	45,62
9,50	69	19	10	4	32,81	43,69	50,94		
10,00	72	22	10	4	22,21	33,55	39,14	31,03	42,88
11,00	79	22	12	4	30,90	43,66	50,92		
12,00	83	26	12	4	28,04	38,78	45,23	41,00	56,77
13,00	83	26	12	4	37,13	53,94	62,90		
14,00	83	26	12	4	35,03	49,89	61,38	50,95	60,48
15,00	83	26	12	4	42,63	58,81	68,59		
16,00	92	32	16	4	41,60	57,83	68,40	59,71	71,62
17,00	92	32	16	4	50,12	70,25	81,91		
18,00	92	32	16	4	51,24	70,34	83,20	72,82	89,58
19,00	92	31	16	4	60,67	80,74	94,15		
20,00	104	38	20	4	60,67	80,74	94,15	85,64	116,38
22,00	104	38	20	4	69,46	111,92	130,52	112,86	137,25
24,00	121	45	25	5	86,83	121,25	153,80		
25,00	121	45	25	5	86,32	128,15	153,08	145,60	180,99
26,00	121	45	25	5	108,34*	148,62	188,51*		
28,00	121	45	25	5	119,11	159,69	192,61		
30,00	121	45	25	6	138,47	177,25	217,00		
32,00	133	53	32	6	141,97	181,33	222,00		
36,00	133	53	32	6	215,01	260,35	318,69		
40,00	155	63	32	6	258,47*	316,61	387,57*		

DIN 844/L		MATÉRIEL		FINITION		QUALITÉ			
L1 mm	L2 mm	D2 mm	Z	FF21	FF23	FT21	FP20		
				HSSCo 8% BRILLANT ★★	HSSCo 8% TiAlN ★★★	HSSCo 8% TiAlSiN ★★★★	ASP 60 BRILLANT Premium Quality		
				€	€	€	€		
52	7	6	4						
54	10	6	4	19,12	28,12	32,79	30,68		
56	12	6	4	19,12	28,12	32,95			
56	12	6	4	18,03	26,42	30,93	30,68		
59	15	6	4	25,26	34,11	39,76			
63	19	6	4	18,03	28,14	32,80	30,68		
63	19	6	4	25,26	34,11	39,76			
68	24	6	4	18,03	26,42	30,93	30,68		
68	24	6	4	25,10	34,11	39,76			
68	24	6	4	19,21	28,14	32,80	30,68		
68	24	6	4						
80	30	10	4	29,16	39,14	45,65	45,78		
80	30	10	4						
88	38	10	4	26,49	35,25	41,10	45,78		
88	38	10	4						
88	38	10	4	30,18	41,09	47,93	45,78*		
88	38	10	4						
95	45	10	4	26,60	38,92	45,39	45,78		
102	45	12	4	37,79	51,27	59,81			
110	53	12	4	34,81	48,70	56,82	66,38		
110	53	12	4						
110	53	12	4	45,55	59,38	69,25	76,63		
110	53	12	4						
123	63	16	4	49,80	69,87	81,48	94,95		
123	63	16	4						
123	63	16	4	60,83	83,18	96,99	121,49		
123	63	16	4						
141	75	20	4	71,25	96,06	112,03	148,98		
141	75	20	5	98,79	126,61	147,67	167,11*		
141	75	25	5						
166	90	25	5	121,68	161,71	188,56	242,75		
166	90	25	5						
166	90	25	5	146,50	192,37	224,32			
166	90	25	6	165,35	211,33	246,45			
186	106	32	6	166,71	212,82	248,18			
186	106	32	6	238,95	286,90	334,54			
217	125	32	6	264,85	342,05	400,78			

\*Jusqu'à fin des stocks

**FRAISES ÉBAUCHE MULTIDENTS DIN 844 ET DIN 844/L**

**4-6 Z**     **INOX** **Al** **TOL D1 k12** **TOL D2 h6**

**SÉRIE COURTE**

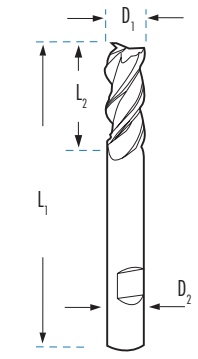

DIN 844		MATÉRIEL			FF25			FF27			FT25		
		FINITION			HSSCo 8%			HSSCo 8%			HSSCo 8%		
		BRILLANT			BRILLANT			TiAIN			TiAISIN		
		QUALITÉ			★★			★★★			★★★★		
		ÉBAUCHE			NR			NR			NR		
D1 mm	L1 mm	L2 mm	D2 mm	Z	€	€	€	€	€	€	€	€	
6,00	57	13	6	4	35,58	41,51	56,73						
7,00	66	16	10	4	38,12	55,04	67,71						
8,00	69	19	10	4	37,15	46,56	60,29						
9,00	69	19	10	4	43,68	57,73	71,02						
10,00	72	22	10	4	37,14	47,57	59,71						
11,00	79	22	12	4	42,32	69,53	85,55						
12,00	83	26	12	4	36,81	59,17	72,79						
13,00	83	26	12	4	48,85	69,05	98,79						
14,00	83	26	12	4	44,38	68,64	84,44						
15,00	83	26	12	4	55,44	82,14	108,68						
16,00	92	32	16	4	47,37	80,88	99,51						
17,00	92	32	16	4	84,28	106,91	131,53						
18,00	92	32	16	4	67,29	89,11	109,63						
19,00	92	31	16	4	98,90	123,92	152,46						
20,00	104	38	20	4	84,33	101,23	133,91						
SANS COUPE AU CENTRE					FF05			FF74			FT05		
22,00	104	38	20	6	107,17	131,97							
24,00	121	45	25	6	134,99	156,49	183,36						
25,00	121	45	25	6	133,72	155,58	182,30						
26,00	121	45	25	6	154,86	190,38	223,06						
28,00	121	45	25	6	168,93	207,13	242,68						
30,00	121	45	25	6	181,47	226,70	265,63						
32,00	133	53	32	6	205,59	243,84	285,69						
36,00	133	53	32	6	243,66	280,98	329,23						
40,00	155	63	32	6	273,93	325,36	381,24						

**SÉRIE LONGUE**



DIN 844/L		MATÉRIEL			FF29			FF31			FT29		
		FINITION			HSSCo 8%			HSSCo 8%			HSSCo 8%		
		BRILLANT			BRILLANT			TiAIN			TiAISIN		
		QUALITÉ			★★			★★★			★★★★		
		ÉBAUCHE			NR			NR			NR		
L1 mm	L2 mm	D2 mm	Z	€	€	€	€	€	€	€	€	€	
68	24	6	4	38,44	55,37	75,70							
80	30	10	4	52,11 *	69,97 *	86,07 *							
88	38	10	4	46,48	64,74	79,65							
88	38	10	4	57,32	70,95	87,27							
95	45	10	4	45,85	60,30	74,19							
102	45	12	4	74,34	91,47	112,54							
110	53	12	4	54,22	72,88	89,68							
110	53	12	4										
110	53	12	4	59,16	82,34	101,33							
110	53	12	4										
123	63	16	4	70,89	99,90	122,93							
123	63	16	4										
123	63	16	4	79,75	115,66	143,75							
123	63	16	4										
141	75	20	4	91,50	123,97	169,46							
					FF08			FF58			FT08		
141	75	20	6	124,51	176,79	207,14							
141	75	25	6										
166	90	25	6	157,26	209,44	245,40							
166	90	25	6										
166	90	25	6	177,32	240,78	282,12							
166	90	25	6	229,92	287,61	337,01							
186	106	32	6	240,46	294,04	344,53							
186	106	32	6	288,75	351,12	411,41							
217	125	32	6	341,39	437,04	512,10							

\*Jusqu'à fin des stocks

**FRAISES FINITION, SANS COUPE AU CENTRE, MULTIDENTS DIN 844 ET DIN 844/L**
**4-6 Z**

**INOX**
**Al**
**TOL D1  
k10**
**TOL D2  
h6**

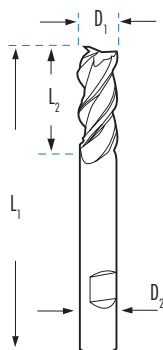
**SÉRIE COURTE**
**SÉRIE LONGUE**

DIN 844					FF03	FF04	FF54	FT04	DIN 844/L					FF07	FF57	FT07
MATÉRIEL					HSS	HSSCo 8%	HSSCo 8%	HSSCo 8%	MATÉRIEL					HSSCo 8%	HSSCo 8%	HSSCo 8%
FINITION					BRILLANT	BRILLANT	TiAIN	TiAISIN	FINITION					BRILLANT	TiAIN	TiAISIN
QUALITÉ					★	★★	★★★	★★★★	QUALITÉ					★★	★★★	★★★★
D1 mm	L1 mm	L2 mm	D2 mm	Z	€	€	€	€	L1 mm	L2 mm	D2 mm	Z	€	€	€	
2,00	51	7	6	4	11,28	14,79	23,80	27,77	54	10	6	4	18,50	28,62	33,53	
2,50	52	8	6	4	11,28	14,79*	23,80*	27,77*	56	12	6	4	18,50	28,62	33,53	
3,00	52	8	6	4	11,28	14,79	23,80	27,77	56	12	6	4	18,50	28,62	33,53	
3,50	55	11	6	4	11,65	15,25*	24,34*	28,36*	59	15	6	4	24,33	35,72	41,86	
4,00	55	11	6	4	11,28	14,79	23,80	27,77	63	19	6	4	18,50	29,76	34,88	
4,50	57	13	6	4	11,65		24,34		63	19	6	4	24,33	35,72	41,86	
5,00	57	13	6	4	11,28	14,79	23,80	27,77	68	24	6	4	18,50	29,76	34,88	
5,50	57	13	6	4	17,53	23,00*	31,99*	37,30*	68	24	6	4	24,33	35,72	41,86	
6,00	57	13	6	4	11,28	14,79	23,80	27,77	68	24	6	4	18,50	29,76	34,88	
6,50	66	16	10	4	17,53*	23,00*	33,10*	38,62*	68	24	6	4				
7,00	66	16	10	4	16,55	21,72	31,90	37,19	80	30	10	4	27,99	41,07	48,14	
7,50	69	16	10	4	20,74	27,18*	37,08	43,24*	80	30	10	4				
8,00	69	19	10	4	12,88	16,69	27,04	31,54	88	38	10	4	25,69	38,71	45,34	
8,50	69	19	10	4	21,61				88	38	10	4				
9,00	69	19	10	4	17,31	22,68	33,88	39,51	88	38	10	4	29,06	43,32	50,77	
9,50	72	22	10	4	23,46	29,99*	41,25	48,09*	88	38	10	4				
10,00	72	22	10	4	15,71	20,58	31,92	37,21	95	45	10	4	25,98	41,19	48,28	
11,00	79	22	12	4	21,64	28,40	41,18	48,02	102	45	12	4	34,95	51,98	60,92	
12,00	83	26	12	4	18,66	24,56	37,03	43,19	110	53	12	4	32,46	49,44	57,93	
13,00	83	26	12	4	27,83	36,65	50,46	58,83	110	53	12	4				
14,00	83	26	12	4	26,32	34,44	48,54	56,59	110	53	12	4	42,43	59,99	70,28	
15,00	83	26	12	4	30,04	39,33	55,91	65,18	110	53	12	4				
16,00	92	32	16	4	29,29	38,37	54,98	64,11	123	63	16	4	46,36	70,91	83,09	
17,00	92	32	16	4	36,10	47,50	65,74	76,65	123	63	16	4				
18,00	92	32	16	4	36,04	47,29	65,74	76,65	123	63	16	4	56,63	84,26	98,71	
19,00	92	31	16	4	42,68	55,64	75,42	87,97	123	63	16	4				
20,00	104	38	20	4	42,68	55,64	75,42	87,97	141	75	20	4	66,32	96,69	113,30	
22,00	104	38	20	4	58,65	77,22	104,41	121,74	141	75	20	5	91,99	127,09	148,92	
24,00	121	45	25	5	72,84	95,96	122,72	143,12	141	75	25	5				
25,00	121	45	25	5	72,84	95,96	122,72	143,12	166	90	25	5	122,01	162,72	190,65	
26,00	121	45	25	5	91,07	119,96*	155,14*	180,90*	166	90	25	5				
28,00	121	45	25	5	91,50	120,53	159,33	185,79	166	90	25	5	149,14	200,38	234,79	
30,00	121	45	25	6	105,57	138,28	177,66	207,20	166	90	25	6	170,68	222,14	260,27	
32,00	133	53	32	6	108,57	141,85	181,80	212,00	186	106	32	6	170,41	223,72	262,11	
36,00	133	53	32	6	142,08	187,13	227,64	265,45	186	106	32	6	243,05	307,38	360,16	
40,00	143	63	32	6	170,34	224,93	279,34	325,76	217	125	32	6	270,17	413,11	484,05	

\*Jusqu'à fin des stocks





**FRAISES SÉRIE SUPER-COURTE ET EXTRA-COURTE 3 DENTS**
**3 Z**

**INOX**
**Al**
**TOL D1**  
e8

**TOL D2**  
h6

**SÉRIE SUPER-COURTE**
**SÉRIE EXTRA-COURTE**

D1 mm	L1 mm	L2 mm	D2 mm	Z	FF51	
					MATÉRIEL FINITION	€
					HSSCo 8%	
					BRILLANT	
1,00	34	2	6	3		13,62
1,50	34	3	6	3		13,62
2,00	35	4	6	3		13,60
2,50	36	5	6	3		13,60
3,00	36	5	6	3		13,60
3,50	37	6	6	3		13,60
4,00	38	7	6	3		13,60
4,50	38	7	6	3		13,60
5,00	39	8	6	3		13,60
5,50	39	8	6	3		13,60
6,00	39	8	6	3		13,60
6,50	42	10	8	3		18,71
7,00	42	10	8	3		18,71
7,50	42	10	8	3		18,71
8,00	43	11	8	3		18,71
8,50	48	11	10	3		21,41
9,00	48	11	10	3		21,41
9,50	48	11	10	3		21,41
10,00	50	13	10	3		21,41



D1 mm	L1 mm	L2 mm	D2 mm	Z	FF53	
					MATÉRIEL FINITION	€
					HSSCo 8%	
					BRILLANT	
2,00	38	7	6	3		14,48
2,50	39	8	6	3		14,48
3,00	39	8	6	3		14,48
3,50	41	10	6	3		14,48
4,00	42	11	6	3		14,48
4,50	42	11	6	3		14,48
5,00	44	13	6	3		14,48
5,50	44	13	6	3		14,48
6,00	44	13	6	3		14,48
6,50	48	16	8	3		20,34
7,00	48	16	8	3		20,34
8,00	51	19	8	3		20,34
8,50	56	19	10	3		23,24
9,00	56	19	10	3		23,24
10,00	59	22	10	3		23,24



**LIMES ROTATIVES EN CARBURE POUR MATÉRIAUX COMPOSITES, FIBRE DE CARBONE, PANNEAU PHÉNOLIQUE, ETC...**

**CARBURE**

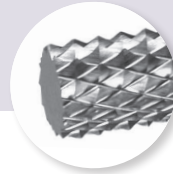
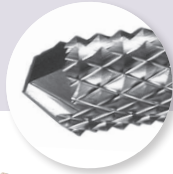

**CONDITIONS DE COUPE**

D <sub>1</sub> mm	RPM rev./min	AVANCE mm/min
1.50	60.000	3.000
2.00	50.000	2.500
3.00	32.000	1.600
5.00	20.000	1.200
6.00	16.000	1.000
6.35	14.000	1.000
8.00	9.000	700
10.00	7.000	550
12.00	6.000	450

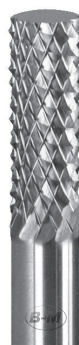

**RFC**

**RFCTL**

**RF**

**RFTL**

**RFF**

**RFFTL**

D <sub>1</sub> mm	L <sub>1</sub> mm	L <sub>2</sub> mm	D <sub>2</sub> mm		€	TiAlN	€		€	TiAlN	€		€	TiAlN	€		
1,50	38	5	3,00	RFC0150	18,47		RFC0150TL	27,89	RF0150	17,50		RF0150TL	26,94	RFF0150		RFF0150TL	
2,00	38	10	3,00	RFC0200	18,47		RFC0200TL	27,89	RF0200	17,50		RF0200TL	26,94	RFF0200		RFF0200TL	
3,00	38	12	3,00	RFC0300	18,47		RFC0300TL	27,89	RF0300	17,50		RF0300TL	26,94	RFF0300	18,47	RFF0300TL	27,89
5,00	50	16	5,00	RFC0500	36,63		RFC0500TL	46,07	RF0500	33,27		RF0500TL	42,70	RFF0500	36,63	RFF0500TL	46,07
6,00	63	25	6,00	RFC0600	40,94		RFC0600TL	51,73	RF0600	37,12		RF0600TL	47,92	RFF0600	40,94	RFF0600TL	51,73
6,35	75	30	6,35	RFC0635	48,36		RFC0635TL	59,87	RF0635	44,27		RF0635TL	55,78	RFF0635	48,36	RFF0635TL	59,87
8,00	63	25	8,00	RFC0800	61,65		RFC0800TL	70,88	RF0800	55,96		RF0800TL	65,19	RFF0800	61,65	RFF0800TL	70,88
10,00	63	25	10,00	RFC1000	69,11		RFC1000TL	77,66	RF1000	62,84		RF1000TL	71,38	RFF1000	69,11	RFF1000TL	77,66
12,00	75	25	12,00	RFC1200	81,09		RFC1200TL	90,97	RF1200	73,73		RF1200TL	83,60	RFF1200	81,09	RFF1200TL	90,97

**NEW**

**CARBURE**



**PHENOLIC**

• Géométrie multi-coups adaptée au travail des matériaux composites afin d'éviter le délaminage de la fibre de carbone et de la fibre de verre. Apte pour la transformation de panneaux phénoliques.

**CONDITIONS DE COUPE**

D <sub>1</sub> mm	RPM rev./min	AVANCE mm/min
3,00	15.000	2.250
4,00	12.000	1.800
5,00	10.000	1.800
6,00	8.500	1.700
8,00	6.500	1.950
10,00	5.500	1.650
12,00	4.500	1.550



**FC11**

**FC12**

**FC13**

**FC14**

D <sub>1</sub> mm	L <sub>1</sub> mm	L <sub>2</sub> mm	D <sub>2</sub> mm	À Droite	€	Droite	€	À Gauche	€	Boule	€
3,00	45	10	3,00	FC1133	34,95	FC1233	34,95	FC1333	34,95	FC1433	36,47
3,00	60	10	6,00	FC1136	39,89	FC1236	39,89	FC1336	39,89	FC1436	39,89
4,00	60	15	4,00	FC1144	45,59	FC1244	45,59	FC1344	45,59	FC1444	49,01
4,00	60	15	6,00	FC1146	72,18	FC1246	72,18	FC1346	45,59	FC1446	73,70
5,00	60	15	5,00	FC1155	61,16	FC1255	61,16	FC1355	61,16	FC1455	61,16
6,00	70	25	6,00	FC1166	74,46	FC1266	74,46	FC1366	74,46	FC1466	70,28
8,00	80	30	8,00	FC1188	113,97	FC1288	113,97	FC1388	113,97	FC1488	122,32
10,00	80	35	10,00	FC111010	170,95	FC121010	170,95	FC131010	170,95	FC141010	170,95
12,00	90	40	12,00	FC111212	227,55	FC121212	227,55	FC131212	227,55	FC141212	235,53

**FRAISES HSSCo 1 DENT (POUR ALUMINIUM ET PVC)**

HSSCo

Al

PVC

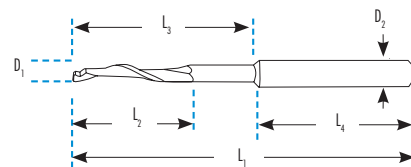
TOL D1  
k12TOL D2  
h6

## SÉRIE COURTE



## SÉRIE LONGUE



## FF13

	D1 mm	L1 mm	L2 mm	D2 mm	HSSCo €	TiN €
FF1381	1,0	60	10	8	43,46	61,20
FF1382	2,0	60	10	8	43,46	61,20
FF1383	3,0	60	10	8	16,86	24,61
FF1384	4,0	60	12	8	16,86	24,61
FF1385	5,0	60	13	8	16,86	24,61
FF1386	6,0	60	14	8	17,47	25,50
FF1387	7,0	60	14	8	18,21	25,62
FF1388	8,0	80	14	8	18,21	25,62
FF131010	10,0	80	15	10	22,84	29,98
FF131212	12,0	80	35	12	58,70	73,37
FF131414	14,0	100	40	12	70,79	88,49
FF131616	16,0	100	40	16	75,61	94,51
FF132020	20,0	100	40	20	85,71	107,14
FF1361	1,0	45	6	6	30,32	40,22
FF13615	1,5	45	6	6	30,32	40,22
FF1362	2,0	45	6	6	30,32	40,22
FF1363	3,0	60	12	6	16,86	23,58
FF1364	4,0	60	12	6	16,86	23,58
FF1365	5,0	60	12	6	16,86	23,58
FF1366	6,0	60	14	6	16,86	23,58

## FF14

	D1 mm	L1 mm	L2 mm	L3 mm	D2 mm	HSSCo €	TiN €
FF1483	3	80	16	45	8	29,03	36,84
FF1484	4	80	16	45	8	24,95	32,71
FF1485	5	80	16	45	8	24,95	32,71
FF1486	6	90	16	45	8	24,95	32,71
FF1487	7	90	20	50	8	32,00	40,34
FF1488	8	100	30	70	8	28,93	37,19
FF1465	5	80	14	45	6	24,71	32,71
FF1466	6	80	14	45	6	24,71	32,71

## SÉRIE EXTRA LONGUE



## FF14-E

	D1 mm	L1 mm	L2 mm	L3 mm	D2 mm	L4 mm	HSSCo €	TiN €
FF1485-E	5	100	30	55	8	45	24,89	31,81
FF1485-EL	5	100	50	-	8	50	28,97	41,14

## POUR PROFILÉS MÉTALLIQUES

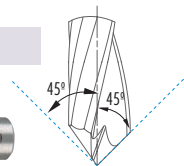

## FF14

	D1 mm	L1 mm	L3 mm	D2 mm	HSSCo €	TiN €
FF14848040	4	80	40	8	61,22	70,40
FF148411040	4	110	40	8	81,49	93,72
FF14858040	5	80	40	8	59,92	68,91
FF148511040	5	110	40	8	83,18	95,66
FF14868040	6	80	40	8	50,29	57,84
FF148611040	6	110	40	8	83,18	95,66



## POUR ALUMINIUM LAQUÉ



## FF50

	D1 mm	L1 mm	L2 mm	L3 mm	D2 mm	HSSCo €	TiN €
FF5084	4	80	16	35	8	23,58	32,16
FF5085	5	80	18	35	8	23,58	32,16

## LONGUEURS SPÉCIALES

## FF14 Spéciales

	D1 mm	L1 mm	L2 mm	L3 mm	D2 mm	HSSCo €
FF148412020	4	120	20	-	8	26,55
FF14856018	5	60	18	-	8	21,90
FF14859025	5	90	25	-	8	28,55
FF148510025	5	100	25	-	8	26,54
FF148512014	5	120	14	-	8	26,54
FF14851001817	5	100	18	35	8	26,98
FF14851201461	5	120	14	75	8	36,33
FF14851201817	5	120	18	35	8	36,33
FF1486801421	6	80	14	35	8	30,11
FF14861001835	6	100	18	35	8	30,11
FF14861201461	6	120	14	75	8	43,54

## FF14 Spéciales

	D1 mm	L1 mm	L2 mm	L3 mm	D2 mm	HSSCo €
FF14861003045	6	100	30	45	8	36,51
FF14861006040	6	100	60	-	8	46,87
FF14888025	8	80	25	-	8	23,71
FF148810014	8	100	14	-	8	26,22
FF148812014	8	120	14	-	8	28,46
FF14881201476	8	120	14	90	8	34,34
FF14898014	9	80	14	-	8	27,50
FF148108014	10	80	14	-	8	29,28
FF1410101003040	10	100	30	70	10	35,74
FF1410101201481	10	120	14	95	10	38,05
FF14101012014	10	120	14	-	10	30,66
FF148128014	12	80	14	-	8	33,20

**FRAISES CARBURE 1 DENT (POUR ALUMINIUM ET PVC)**

**CARBURE** **Al** **PVC** **TOL h10** **TOL D2 h6**

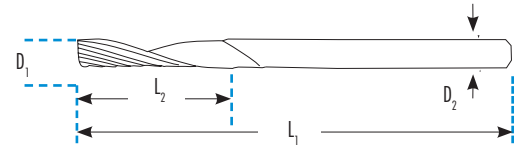

**HÉLICE A - SÉRIE COURTE**



**HÉLICE A - SÉRIE LONGUE**



Helix A	D <sub>1</sub> mm	L <sub>1</sub> mm	L <sub>2</sub> mm	D <sub>2</sub> mm	FMGA13	
					CARBURE	€
FMGA13305	0,5	39	1,5	3		54,01
FMGA1331	1,0	39	3,0	3		36,86
FMGA13315	1,5	39	4,0	3		33,16
FMGA1322	2,0	40	10,0	2		27,93
FMGA13325	2,5	40	12,0	3		31,40
FMGA1333	3,0	40	12,0	3		25,32
FMGA1336	3,0	64	12,0	6		43,47
FMGA1338	3,0	64	12,0	8		59,97
FMGA1344	4,0	50	16,0	4		27,85
FMGA1346	4,0	64	16,0	6		43,91
FMGA1348	4,0	64	16,0	8		69,78
FMGA135550	5,0	50	16,0	5		28,89
FMGA1355	5,0	64	16,0	5		31,66
FMGA1356	5,0	64	16,0	6		49,43
FMGA1358	5,0	64	16,0	8		71,36
FMGA136650	6,0	50	16,0	6		38,86
FMGA1366	6,0	64	20,0	6		42,80
FMGA1368	6,0	64	20,0	8		72,46
FMGA1378	7,0	64	20,0	8		81,23
FMGA138816	8,0	66	16,0	8		44,06
FMGA1388	8,0	76	38,0	8		58,43
FMGA13101015	10,0	76	15,0	10		68,68
FMGA131010	10,0	76	30,0	10		73,24

Helix A	D <sub>1</sub> mm	L <sub>1</sub> mm	L <sub>2</sub> mm	D <sub>2</sub> mm	FMGA13E	
					CARBURE	€
FMGA133312E	3	70	12	3		30,75
FMGA133322E	3	70	22	3		32,05
FMGA133332E	3	70	32	3		34,11
FMGA134415E	4	70	15	4		39,99
FMGA134425E	4	70	25	4		42,36
FMGA134435E	4	70	35	4		45,25
FMGA135517E	5	80	17	5		49,36
FMGA1355E	5	80	38	5		52,16
FMGA136620E	6	85	20	6		55,36
FMGA1366E	6	85	40	6		57,61
FMGA138825E	8	90	25	8		71,25
FMGA1388E	8	90	38	8		74,03
FMGA1388EX	8	110	43	8		83,15
FMGA131010E	10	100	40	10		106,15
FMGA131010EL	10	120	60	10		154,59

**HÉLICE A - AVEC COU**



Helix A	D <sub>1</sub> mm	L <sub>1</sub> mm	L <sub>2</sub> mm	D <sub>2</sub> mm	FMGA13	
					CARBURE	€
FMGA13488016	4	8	80	16	29	69,95
FMGA13588016	5	8	80	16	29	69,95
FMGA13689016	6	8	90	16	29	69,95

**VITESSE DE COUPE POUR FRAISE 1 DENT**

D <sub>1</sub> mm	HSSCo		CARBURE	
	Aluminium (R.P.M.)	PVC (R.P.M.)	Aluminium (R.P.M.)	PVC (R.P.M.)
3,00	12000	12000	19000	19000
4,00	11000	11000	18000	18000
5,00	10000	10000	18000	18000
6,00	10000	10000	17000	17000
7,00	9000	9000	17000	17000
8,00	9000	9000	16000	16000
9,00	9000	9000	16000	16000
10,00	9000	9000	16000	16000

Note: Pour la série longue il convient de réduire les RPM de 15%

**FRAISES CARBURE 1 DENT (POUR ALUMINIUM ET PVC)**

CARBURE

Al

PVC

TOL

h10

TOL D2

h6

HÉLICE B



HÉLICE C

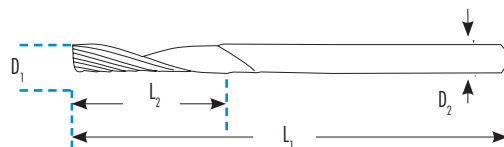

FMGA13HI

B	D1 mm	L1 mm	L2 mm	D2 mm	CARBURE
					€
FMGA1333HI	3	50	8	3	33,94
FMGA1344HI	4	64	12	4	33,95
FMGA1355HI	5	64	16	5	36,75
FMGA1366HI	6	64	20	6	55,49
FMGA1388HI	8	76	38	8	73,43
FMGA13101HI	10	76	35	10	85,03

GOUJURE DROITE



FMGA13R

R	D1 mm	L1 mm	L2 mm	D2 mm	CARBURE
					€
FMGA1346R	4	64	16	6	46,05
FMGA1356R	5	64	20	6	46,05
FMGA1366R	6	64	25	6	53,61
FMGA1388R	8	64	25	8	79,30
FMGA13101OR	10	88	35	10	103,78
FMGA131212R	12	88	35	12	149,79

FMGA13CO

C	D1 mm	L1 mm	L2 mm	D2 mm	CARBURE
					€
FMGA1366CO	6	64	25	6	124,52
FMGA1388CO	8	64	25	8	172,18
FMGA13101OCO	10	76	35	10	202,37
FMGA131212CO	12	76	35	12	268,49

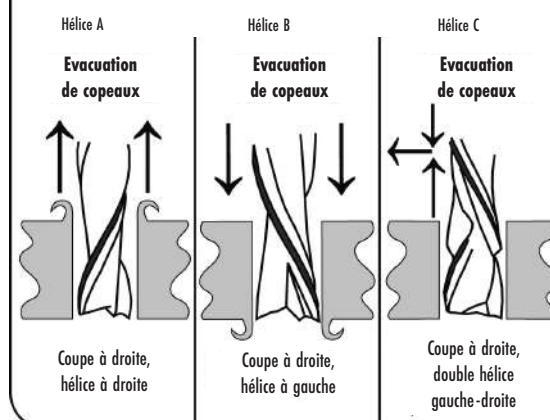
**TYPES D'HÉLICE**

**LIMES ROTATIVES CARBURE POUR LA RÉPARATION DE PNEUS**

CARBURE



RN

	D1 mm	L1 mm	L2 mm	D2 mm	€
RN0300	3,00	50	25	3	17,97
RN0600	6,00	80	50	6	43,34
RN0800	8,00	110	50	8	48,82
RN1000	10,00	110	60	10	76,61

**LIMES ROTATIVES EN CARBURE, ACCESSOIRES ROTOZIP**

Réf.: RR0317



Réf.: RR0635



Réf.: RR0435



Réf.: RR0247

RR

	POUR TRAVAILLER DANS	D1 mm	L1 mm	L2 mm	D2 mm	€
RR0317	Carrelage	3,17	50	25	3,17	20,72*
RR0635	Carrelage	6,35	50	25	6,35	34,70*
RR0435	Plâtre	6,35	52	32	6,35	43,44*
RR0247	Mortier	2,47	38	14	3,17	15,22*

\*Jusqu'à fin des stocks

**FRAISES POUR RAINURES**

Réf. FF17

**RAINURES  
EN "T"**

**DIN  
851A**

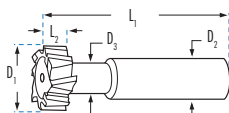

**TOL D1  
d11**    **TOL D2  
h6**

**FF17**

D1 x L2 mm	D2 mm	D3 mm	Z	L1 mm	FF17	
					HSSCo €	TiAlN €
11,0x4,0	10	4	4	53,5	81,54	100,66
12,5x6,0	10	5	6	57,0	82,79	103,99
16,0x8,0	10	7	6	62,0	86,59	110,39
18,0x8,0	12	8	8	70,0	90,33	116,88
21,0x9,0	12	10	8	74,0	96,99	136,88
25,0x11,0	16	12	8	82,0	112,90	153,75
32,0x14,0	16	15	10	90,0	148,82	207,38
40,0x18,0	25	19	10	108,0	239,34	333,56
50,0x22,0	32	25	10	124,0	334,15	438,22
60,0x28,0	32	30	10	139,0	349,32	458,13
72,0x35,0	32	35	10	153,0	364,49	478,05

**FRAISE 1/4 DE CERCLE**

Réf. FF17C

**RAINURES  
EN "T"**

**DIN  
851B**

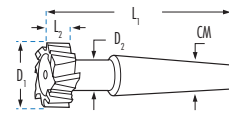

**TOL D2  
h12**

**FF17C**

D1 x L2 mm	CM	PAS	D2 mm	L1 mm	FF17C	
					HSSCo €	TiAlN €
18,0x8,0	1	M6	8	70	98,87	122,61
21,0x9,0	2	M10	10	74	105,85	131,25
25,0x11,0	2	M10	12	82	113,84	141,15
32,0x14,0	2	M10	16	90	157,87	195,76
40,0x18,0	3	M12	20	108	230,29	285,57
50,0x22,0	4	M16	25	124	354,87	440,02
60,0x28,0	4	M16	31	139	469,53	582,22
72,0x35,0	5	M20	36	153	637,32	790,26

**FRAISES POUR RAINURES**

**4 Z**

**HSSCo  
8%**

**DIN  
6518N**

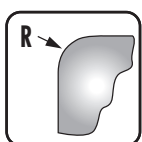
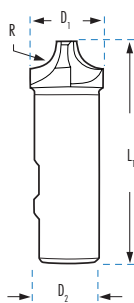

**FF1/4R**

	TOL H11		js 15 D1 mm	TOL h6		L1 mm	€
	R	D1		D2	L1		
FF1/4R1	1,0	8	10	60	60,87		
FF1/4R1.50	1,5	9	10	60	69,32		
FF1/4R2	2,0	10	10	60	58,33		
FF1/4R2.50	2,5	11	10	60	67,09		
FF1/4R3	3,0	12	12	60	66,85		
FF1/4R3.50	3,5	13	12	60	87,07		
FF1/4R4	4,0	14	12	60	74,21		
FF1/4R4.50	4,5	15	12	60	101,03		
FF1/4R5	5,0	16	12	60	82,33		
FF1/4R5.50	5,5	19	16	67	101,03		
FF1/4R6	6,0	20	16	67	84,84		
FF1/4R6.50	6,5	21	16	71	128,59		
FF1/4R7	7,0	22	16	71	112,10		
FF1/4R7.50	7,5	23	16	71	139,96		
FF1/4R8	8,0	24	16	71	112,10		
FF1/4R8.50	8,5	25	25	85	171,45		
FF1/4R9	9,0	26	25	85	138,94		
FF1/4R9.50	9,5	27	25	85	180,20		
FF1/4R10	10,0	28	25	85	140,38		
FF1/4R10.50	10,5	31	25	90	209,93		
FF1/4R11	11,0	32	25	90	165,91		
FF1/4R12	12,0	34	25	90	166,23		
FF1/4R12.50	12,5	41	25	100	215,87		
FF1/4R13	13,0	42	25	100	250,09		
FF1/4R14	14,0	44	25	100	249,12		
FF1/4R15	15,0	46	25	100	310,12		
FF1/4R16	16,0	48	25	100	307,15		
FF1/4R18	18,0	52	32	112	367,66		
FF1/4R20	20,0	56	32	112	405,83		

Réf. FF16

**TYPE  
WOODRUFF**

**DIN  
850B**

**TOL D1  
h12**

**TOL D2  
h6**

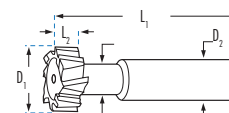

**FF16**

D1 x L2 mm	D2 mm	Z	L1 mm	FF16	
				HSSCo €	TiAlN €
4,5x1,0	6	6	50	52,87	62,84
7,5x1,5	6	6	50	40,50	48,90
7,5x2,0	6	6	50	40,50	48,90
10,5x2,0	6	6	50	51,89	62,86
10,5x2,5	6	6	50	51,89	62,86
10,5x3,0	6	6	50	51,89	62,86
13,5x3,0	10	6	56	51,42	64,51
13,5x4,0	10	6	56	54,67	68,59
16,5x3,0	10	6	56	59,10	78,71
16,5x4,0	10	6	56	59,10	78,71
16,5x5,0	10	6	56	59,10	76,16
19,5x4,0	10	8	63	74,76	99,21
19,5x5,0	10	8	63	74,76	95,07
19,5x6,0	10	8	63	74,76	95,07
22,5x5,0	10	8	63	77,80	104,70
22,5x6,0	10	8	63	72,88	98,56
22,5x8,0	10	8	63	72,88	98,56
25,5x6,0	10	10	63	95,89	137,16
28,5x6,0	10	10	63	97,53	138,80
28,5x8,0	10	10	63	97,53	138,80
28,5x10,0	12	10	71	97,53	138,80
32,5x7,0	12	10	71	118,54	162,79
32,5x8,0	12	10	71	118,54	162,79
32,5x10,0	12	10	71	107,65	147,84
45,5x10,0	12	12	71	151,17	215,97

**FRAISES À CÔNE INVERSÉ ET CÔNE DROIT À QUEUE CYLINDRIQUE**

 Réf. FF98  
 Réf. FF99

**HSSCo**
**DIN  
1833A**
**TOL D1  
js16**
**TOL D2  
h6**

 Réf. FF97  
 Réf. FF95

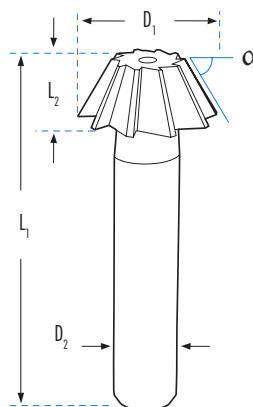
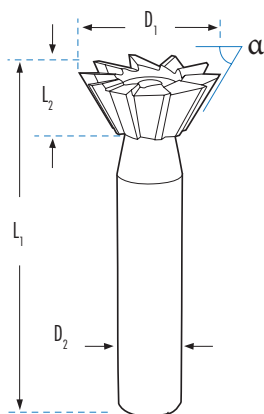
**HSSCo**
**DIN  
1833B**
**TOL D1  
js16**
**TOL D2  
h6**

**FF98**

<b>45°</b>	D1 mm	α	D2 mm	L1 mm	L2 mm	Z	€
FF981600	16	45°	12	60	4,0	8	57,35
FF982000	20	45°	12	63	5,0	10	72,49
FF982500	25	45°	12	67	6,3	12	90,12
FF983200	32	45°	16	71	8,0	14	116,95

**FF97**

<b>45°</b>	D1 mm	α	D2 mm	L1 mm	L2 mm	Z	€
FF971600	16	45°	12	60	4,0	8	54,76
FF972000	20	45°	12	63	5,0	10	69,59
FF972500	25	45°	12	67	6,3	12	87,10
FF973200	32	45°	16	71	8,0	12	113,03

**FF99**

<b>60°</b>	D1 mm	α	D2 mm	L1 mm	L2 mm	Z	€
FF991600	16	60°	12	60	6,3	8	57,13
FF992000	20	60°	12	63	8,0	10	72,59
FF992500	25	60°	12	67	10,0	12	90,11
FF993200	32	60°	16	71	12,5	14	117,25

**FF95**

<b>60°</b>	D1 mm	α	D2 mm	L1 mm	L2 mm	Z	€
FF951600	16	60°	12	60	6,3	8	54,54
FF952000	20	60°	12	63	8,0	10	69,45
FF952500	25	60°	12	67	10,0	12	87,29
FF953200	32	60°	16	71	12,5	12	112,75

**DIMENSIONS SPÉCIALES**
**FF99**





FF991600-50	16	50°	12	60	5,0	8	79,94
FF992000-50	20	50°	12	63	6,3	10	85,20
FF992500-50	25	50°	12	67	8,0	12	105,28
FF991600-55	16	55°	12	60	5,6	8	79,94
FF992000-55	20	55°	12	63	7,1	10	85,20
FF992500-55	25	55°	12	67	9,0	12	105,28
FF991600-75	16	75°	12	60	8,0	8	79,94
FF992500-75	25	75°	12	67	10,0	12	105,28
FF991600-80	16	80°	12	60	8,0	8	79,94
FF992500-80	25	80°	12	67	10,0	12	105,28
FF991600-85	16	85°	12	60	8,0	8	79,94
FF992500-85	25	85°	12	67	10,0	12	105,28

**DIMENSIONS SPÉCIALES**
**FF95**

FF951600-50	16	50°	12	60	5,0	8	66,74
FF952000-50	20	50°	12	63	6,3	10	85,20
FF952500-50	25	50°	12	67	8,0	12	106,29
FF951600-55	16	55°	12	60	5,6	8	66,74
FF952000-55	20	55°	12	63	7,1	10	85,20
FF952500-55	25	55°	12	67	9,0	12	106,29
FF951600-75	16	75°	12	60	8,0	8	66,74
FF952500-75	25	75°	12	67	10,0	12	106,29



**FRAISES À QUEUE CONIQUE SÉRIE COURTE**

**4-8 Z**      **2 Z** 

**SÉRIE COURTE**

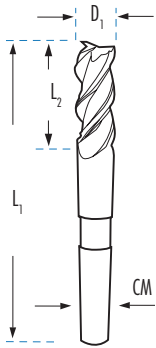

DIN 845B		MATÉRIEL					FF09						FF35			FF39			FF10			FF46			FF48			DIN 326				FF55
		FINITION					HSSCo 8%						HSSCo 8%			HSSCo 8%			HSSCo 8%			HSSCo 8%			HSSCo 8%				HSSCo 8%			
		QUALITÉ					BRILLANT						TIN			TiAIN			BRILLANT			TIN			BRILLANT				BRILLANT			
		ÉBAUCHE					★★						★★★			★★★			★★			★★★			★★★				★★★			
		TOL k10					TOL k10						TOL k10			TOL k12			TOL k12			TOL k12				TOL e8						
D1 mm	L1 mm	L2 mm	Z	CM	PAS	€	€	€	€	€	€	€	€	€	€	€	€	€	€	€	€	L1 mm	L2 mm	Z	€							
10,00	92	22	4	1	M6	47,11	65,73	68,96	87,42	104,26	107,30	83	13	2	67,05																	
12,00	111	26	4	2	M6	63,99	82,48	85,73	89,11	106,46	110,58	86	16	2	69,60																	
14,00	111	26	4	2	M10	70,93	90,34	94,74	101,24	118,96	124,74	101	16	2	72,23																	
15,00	111	26	4	2	M10	72,64	94,40	102,75	126,48	145,44	152,52																					
16,00	117	32	4	2	M10	59,10	78,49	86,61	88,29	126,08	130,96	104	19	2	64,71																	
18,00	117	32	4	2	M10	62,80	81,93	90,39	96,88	135,01	141,60	104	19	2	78,59																	
20,00	123	38	4	2	M10	83,61	103,20	108,17	112,29	150,16	157,45	107	22	2	86,82																	
22,00	123	38	5	2	M10	83,89	106,32	118,76	123,62	161,34	169,17	107	22	2	102,25																	
24,00	147	45	6	3	M12	99,29	114,47	133,30	145,96	211,76	222,04	128	26	2	132,31																	
25,00	154	45	5	3	M12	100,30	123,96	148,81	156,57	219,32	229,98	128	26	2	118,19																	
26,00	147	45	6	3	M12	119,23	151,53	167,41	168,13	236,05	247,56	128	26	2	132,69*																	
28,00	154	50	5	3	M12	124,97	158,82	182,31	175,92	242,78	264,07	128	26	2	141,84																	
30,00	154	50	6	3	M12	165,09	218,14	224,41	220,17	281,90	295,63	128	26	2	173,88																	
32,00	178	53	6	4	M16	177,24	228,77	260,56	244,92	348,70	365,65	157	32	2	195,35																	
36,00	178	53	6	4	M16	213,77	268,28	291,42	296,70	378,52	396,93	157	32	2	249,18																	
40,00	188	63	6	4	M16	237,50	296,94	368,15	377,17	463,50	486,03	163	38	2	287,18																	
45,00	188	63	6	4	M16	337,68	415,40	466,42	428,69	566,44	593,99	163	38	2	414,74																	
50,00	233	75	6	5	M20	414,54	489,16	539,01	549,57	617,64	647,63	203	45	2	521,04																	
56,00	233	75	8	5	M20	561,19	624,46	701,15	782,56	798,30	837,11																					
63,00	241	90	8	5	M20	704,57	758,58	851,74	947,15	974,02	1.021,35																					

\*Jusqu'à fin des stocks

**FRAISES À QUEUE CONIQUE SÉRIE LONGUE DIN 845B/L**
**4-8 Z**

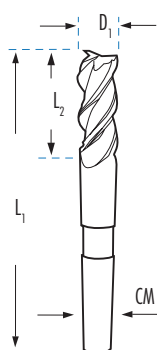
**INOX**
**Al**
**SÉRIE LONGUE**

<b>DIN 845B/L</b>						<b>MATÉRIEL</b> <b>FINITION</b> <b>QUALITÉ</b> <b>ÉBAUCHE</b>		<b>FF11</b> HSSCo 8% BRILLANT ★★ TOL k10 €	<b>FF61</b> HSSCo 8% TiN ★★★ TOL k10 €	<b>FF71</b> HSSCo 8% TiAlN ★★★ TOL k10 €	<b>FF12</b> HSSCo 8% BRILLANT ★★ NR TOL k12 €	<b>FF33</b> HSSCo 8% TiN ★★★ NR TOL k12 €	<b>FF43</b> HSSCo 8% TiAlN ★★★ NR TOL k12 €
						D1 mm	L1 mm	L2 mm	Z	CM	PAS	€	€
10,00	115	45	4	1	M6	89,13	121,00	128,78	127,85	170,44	176,24		
12,00	138	53	4	2	M6	91,33	124,56	132,43	130,10	172,67	180,22		
14,00	138	53	4	2	M10	96,12	135,30	141,21	163,91	211,93	221,18		
15,00	138	53	4	2	M10	105,51	141,86	148,01	188,50	243,51	254,17		
16,00	148	63	4	2	M10	97,14	138,30	144,33	136,33	185,93	194,05		
18,00	148	63	4	2	M10	98,49	151,82	158,41	141,52	191,69	200,06		
20,00	160	75	4	2	M10	129,01	169,83	177,22	139,06	219,95	229,53		
22,00	160	75	5	2	M10	148,98	186,88	195,88	159,43	226,82	236,71		
24,00	192	90	5	3	M12	166,19	241,98	254,89	188,45	295,91	310,81		
25,00	184	80	5	3	M12	167,07	249,71	262,38	189,03	300,18	313,26		
26,00	192	90	5	3	M12	200,64	269,61	283,33	249,24	325,53	339,74		
28,00	192	90	5	3	M12	203,30	285,29	300,50	249,24	325,53	339,74		
30,00	192	90	5	3	M12	231,75	320,34	336,60	275,19	389,90	406,93		
32,00	229	100	6	4	M16	260,95	379,32	398,57	316,00	465,48	485,83		
36,00	231	106	6	4	M16	351,53	425,34	446,92	353,02	523,72	546,57		
40,00	250	125	6	4	M16	390,62	478,58	502,90	384,38	579,84	605,17		
45,00	250	125	6	4	M16	526,46	636,36	670,29	525,30	809,86	845,25		
50,00	268	110	6	5	M20	642,50	745,54	785,34	550,63	982,12	1.025,01		
56,00	308	150	8	5	M20	676,12	778,39	821,29	915,58	1.125,42	1.185,59		
63,00	338	180	8	5	M20	894,35	992,75	1.045,53	1.152,69	1.387,05	1.461,16		

**JEUX DE FRAISES COUPE AU CENTRE EN COFFRETS PLASTIQUE**

**2 Z**  **DIN 327**



**4 Z**  **DIN 844**



<b>RÉFÉRENCE</b>	<b>PTF20</b>	<b>PTF60</b>
<b>N° FRAISES</b>	8	8
<b>TYPE</b>	Réf. FF02	Réf. FF60
<b>QUALITÉ</b>	HSSCo 8%	<b>TiAIN</b>
<b>CONTENU</b>	$\frac{6}{2}$ $\frac{8}{2}$ $\frac{10}{2}$ $\frac{12}{2}$	$\frac{6}{2}$ $\frac{8}{2}$ $\frac{10}{2}$ $\frac{12}{2}$
<b>PRIX €</b>	<b>143,36</b>	<b>221,90</b>

<b>RÉFÉRENCE</b>	<b>PTF24</b>	<b>PTF64</b>
<b>N° FRAISES</b>	8	8
<b>TYPE</b>	Réf. FF18	Réf. FF20
<b>QUALITÉ</b>	HSSCo 8%	<b>TiAIN</b>
<b>CONTENU</b>	$\frac{6}{2}$ $\frac{8}{2}$ $\frac{10}{2}$ $\frac{12}{2}$	$\frac{6}{2}$ $\frac{8}{2}$ $\frac{10}{2}$ $\frac{12}{2}$
<b>PRIX €</b>	<b>173,98</b>	<b>252,01</b>

**2 Z**  **DIN 327**



**4 Z**  **DIN 844**



<b>RÉFÉRENCE</b>	<b>PTF21</b>	<b>PTF61</b>
<b>N° FRAISES</b>	6	6
<b>TYPE</b>	Réf. FF02	Réf. FF60
<b>QUALITÉ</b>	HSSCo 8%	<b>TiAIN</b>
<b>CONTENU</b>	6-8-10-12-16-20	6-8-10-12-16-20
<b>PRIX €</b>	<b>158,16</b>	<b>234,17</b>

<b>RÉFÉRENCE</b>	<b>PTF25</b>	<b>PTF65</b>
<b>N° FRAISES</b>	6	6
<b>TYPE</b>	Réf. FF18	Réf. FF20
<b>QUALITÉ</b>	HSSCo 8%	<b>TiAIN</b>
<b>CONTENU</b>	6-8-10-12-16-20	6-8-10-12-16-20
<b>PRIX €</b>	<b>189,26</b>	<b>264,58</b>

**2 Z**  **DIN 327**



**4 Z**  **DIN 844**



<b>RÉFÉRENCE</b>	<b>PTF22</b>	<b>PTF62</b>
<b>N° FRAISES</b>	6	6
<b>TYPE</b>	Réf. FF02	Réf. FF60
<b>QUALITÉ</b>	HSSCo 8%	<b>TiAIN</b>
<b>CONTENU</b>	4-5-6-8-10-12	4-5-6-8-10-12
<b>PRIX €</b>	<b>98,76</b>	<b>150,71</b>

<b>RÉFÉRENCE</b>	<b>PTF26</b>	<b>PTF66</b>
<b>N° FRAISES</b>	6	6
<b>TYPE</b>	Réf. FF18	Réf. FF20
<b>QUALITÉ</b>	HSSCo 8%	<b>TiAIN</b>
<b>CONTENU</b>	4-5-6-8-10-12	4-5-6-8-10-12
<b>PRIX €</b>	<b>118,47</b>	<b>171,57</b>

**JEUX DE FRAISES COUPE AU CENTRE EN COFFRETS MÉTALLIQUES**

2 Z

DIN  
327

RÉFÉRENCE	FF010787	FF020787	FT020787	FF600787
N° FRAISES	6	6	6	6
TYPE	Réf. FF01	Réf. FF02	Réf. FT02	Réf. FF60
QUALITÉ	HSS	HSSCo 8%	TiAlSiN	TiAlN
CONTENU Ø mm	4 - 5 - 6 - 8 - 10 - 12	4 - 5 - 6 - 8 - 10 - 12	4 - 5 - 6 - 8 - 10 - 12	4 - 5 - 6 - 8 - 10 - 12
PRIX €	96,58	122,29	194,02	175,67
RÉFÉRENCE	FF010447	FF020447	FT020447	FF600447
N° FRAISES	6	6	6	6
TYPE	Réf. FF01	Réf. FF02	Réf. FT02	Réf. FF60
QUALITÉ	HSS	HSSCo 8%	TiAlSiN	TiAlN
CONTENU Ø mm	6 - 8 - 10 - 12 - 16 - 20	6 - 8 - 10 - 12 - 16 - 20	6 - 8 - 10 - 12 - 16 - 20	6 - 8 - 10 - 12 - 16 - 20
PRIX €	144,47	181,75	290,95	262,20

**JEUX DE FRAISES EN COFFRETS MÉTALLIQUES**

4 Z

DIN  
844

RÉFÉRENCE	FF030787	FF040787	FT040787	FF540787
N° FRAISES	6	6	6	6
TYPE	Réf. FF03	Réf. FF04	Réf. FT04	Réf. FF54
QUALITÉ	HSS	HSSCo 8%	TiAlSiN	TiAlN
CONTENU Ø mm	4 - 5 - 6 - 8 - 10 - 12	4 - 5 - 6 - 8 - 10 - 12	4 - 5 - 6 - 8 - 10 - 12	4 - 5 - 6 - 8 - 10 - 12
PRIX €	94,99	125,28	195,23	190,92
RÉFÉRENCE	FF030847	FF040847	FT040847	FF540847
N° FRAISES	6	6	6	6
TYPE	Réf. FF03	Réf. FF04	Réf. FT04	Réf. FF54
QUALITÉ	HSS	HSSCo 8%	TiAlSiN	TiAlN
CONTENU Ø mm	6 - 8 - 10 - 12 - 16 - 20	6 - 8 - 10 - 12 - 16 - 20	6 - 8 - 10 - 12 - 16 - 20	6 - 8 - 10 - 12 - 16 - 20
PRIX €	142,36	190,43	291,79	274,25

RÉFÉRENCE	FF250847	FT250847	FF270847
N° FRAISES	6	6	6
TYPE	Réf. FF25	Réf. FT25	Réf. FF27
QUALITÉ	HSSCo 8%	TiAlSiN	TiAlN
CONTENU Ø mm	6 - 8 - 10 - 12 - 16 - 20	6 - 8 - 10 - 12 - 16 - 20	6 - 8 - 10 - 12 - 16 - 20
PRIX €	294,04	458,79	389,14

4 Z

DIN  
844

NR

**JEUX DE FRAISES EN COFFRETS MÉTALLIQUES**

**4 Z**  **DIN 844**

<b>RÉFÉRENCE</b>	<b>FF180787</b>	<b>FT180787</b>	<b>FF200787</b>
<b>N° FRAISES</b>	6	6	6
<b>TYPE</b>	Réf. FF18	Réf. FT18	Réf. FF20
<b>QUALITÉ</b>	HSSCo 8%	<b>TiAlSiN</b>	<b>TiAlN</b>
<b>CONTENU</b> Ø mm	4 - 5 - 6 - 8 - 10 - 12	4 - 5 - 6 - 8 - 10 - 12	4 - 5 - 6 - 8 - 10 - 12
<b>PRIX €</b>	<b>133,38</b>	<b>196,80</b>	<b>187,62</b>



Réf. FF180787







<b>RÉFÉRENCE</b>	<b>FF180847</b>	<b>FT180847</b>	<b>FF200847</b>
<b>N° FRAISES</b>	6	6	6
<b>TYPE</b>	Réf. FF18	Réf. FT18	Réf. FF20
<b>QUALITÉ</b>	HSSCo 8%	<b>TiAlSiN</b>	<b>TiAlN</b>
<b>CONTENU</b> Ø mm	6 - 8 - 10 - 12 - 16 - 20	6 - 8 - 10 - 12 - 16 - 20	6 - 8 - 10 - 12 - 16 - 20
<b>PRIX €</b>	<b>209,21</b>	<b>307,64</b>	<b>285,70</b>



Réf. FF180847

**PRÉSENTOIR MÉTHACRYLATE** Réf. MF-01 **MF-01**

Contenu: 163 Fraises

Réf. FF13	<b>1 Z</b>	HSSCo	<b>Al</b>	<b>SÉRIE COURTE</b>	Ø	5 x 8	Queue	6 x 8	Queue
					Quantité	5		5	
Réf. FF14	<b>1 Z</b>	HSSCo	<b>Al</b>	<b>SÉRIE LONGUE</b>	Ø	5 x 8	Queue	6 x 8	Queue
					Quantité	5		5	
Réf. FF02	<b>2 Z</b>		HSSCo	<b>DIN 327N</b>		Ø	2 3 4 5 6 7 8 9 10 12 14 16		
					Quantité		5 5 5 5 5 5 5 5 5 5 5 5 3		
Réf. FF18	<b>4 Z</b>		HSSCo	<b>DIN 844N</b>		Ø	2 3 4 5 6 7 8 9 10 12 14 16		
					Quantité		5 5 5 5 5 5 5 5 5 5 5 5 3		
Réf. FF25	<b>4 Z</b>		HSSCo	<b>DIN 844N</b>			Ø	6 7 8 9 10 11 12 14 16	
					Quantité.		3 3 3 3 3 3 3 3 3		



Dimensions: largeur 245 x profondeur 210 x hauteur 350 mm.  
NOTE: Compositions spéciales à la demande

**PRIX 3.851,10 €**

**PARAMÈTRES DE COUPE ORIENTATIFS FRAISES HSSCO 8%**

Fraises

Rose

		DIAMÈTRE Ø (mm)														
		2	4	6	8	10	12	18	22	26	30	32	36	40		
ACIER 70 kg/mm <sup>2</sup>	V/C 39	RPM	6207	3104	2069	1552	1241	1035	690	564	477	414	388	345	310	
	AVANCE (mm/min)	N° lèvres	2	50	56	74	84	82	81	80	81	76	68	68	62	60
		3	74	84	112	126	123	121	120	122	115	102	102	93	89	
4	99	112	149	168	164	161	160	163	153	136	137	124	119			
ACIER TREMPÉ 120 kg/mm <sup>2</sup>	V/C 20	RPM	3183	1592	1061	796	637	531	354	289	245	212	199	177	159	
	AVANCE (mm/min)	N° lèvres	2	25	29	38	43	42	41	41	42	39	35	35	32	31
		3	38	43	57	64	63	62	62	63	59	52	53	48	46	
4	51	57	76	86	84	83	82	83	78	70	70	64	61			
INOX	V/C 15	RPM	2387	1194	796	597	477	398	265	217	184	159	149	133	119	
	AVANCE (mm/min)	N° lèvres	2	19	21	29	32	32	31	31	31	29	26	26	24	23
		3	29	32	43	48	47	47	46	47	44	39	39	36	34	
4	38	43	57	64	63	62	62	63	59	52	53	48	46			
ALUMINIUM	V/C 230	RPM	36606	18303	12202	9151	7321	6101	4067	3328	2816	2440	2288	2034	1830	
	AVANCE (mm/min)	N° lèvres	2	293	329	439	494	483	476	472	479	451	400	403	366	351
		3	439	494	659	741	725	714	708	719	676	600	604	549	527	
4	586	659	879	988	966	952	944	958	901	800	805	732	703			
TITANE	V/C 12	RPM	1910	955	637	477	382	318	212	174	147	127	119	106	95	
	AVANCE (mm/min)	N° lèvres	2	15	17	23	26	25	25	25	24	21	21	19	18	
		3	23	26	34	39	38	37	37	38	35	31	32	29	28	
4	31	34	46	52	50	50	49	50	47	42	42	38	37			

\* Pour fraises revêtues, multiplier les valeurs par 1,3 et pour fraises ASP 60 multiplier les valeurs par 1,8

\* V/C: Vitesse de coupe (m/min)

**PROFONDEUR DE PASSAGE EN FONCTION DE L'OPÉRATION À RÉALISER**

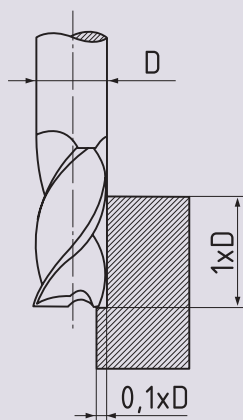

FRAISAGE LATÉRAL

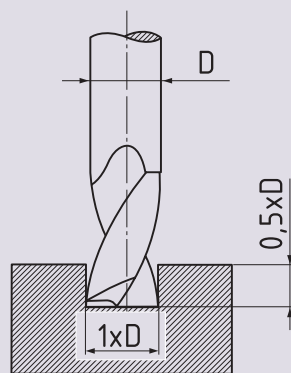

RAINURAGE

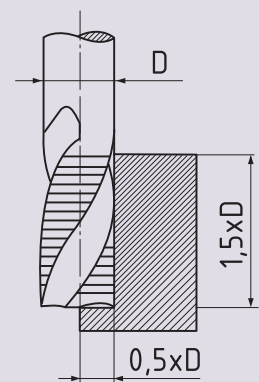

ÉBAUCHE

**BLUE-MASTER®**  
by *celesa*



FRAISES  
CARBURE

**FRAISES CARBURE POUR APPLICATIONS GÉNÉRALES SÉRIE COURTE**

**USAGE GÉNÉRAL**

**CARBURE**



**30° N**

**CYLINDRIQUE**

**2Z**



**3Z**

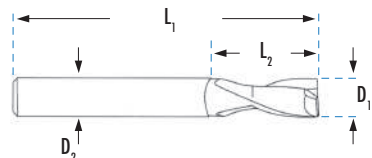

**SÉRIE COURTE**

MATÉRIEL				FMD2		FMD2TL		FMD63		FMD63TL	
FINITION				CARBURE		CARBURE		CARBURE		CARBURE	
QUALITÉ				BRILLANT		TiAlN		BRILLANT		TiAlN	
				★★		★★★		★★		★★★	
				2Z		2Z		3Z		3Z	
D1 mm	L1 mm	L2 mm	D2 mm	€	€	€	€	€	€	€	€
1,00	38	3	3	FMD20100	17,53	FMD20100TiAlN	23,24	FMD630100	17,53	FMD630100TiAlN	23,24
1,00	50	3	4	FMD20100X50	18,78	FMD20100X50TiAlN	25,64	FMD630100X50	18,78	FMD630100X50TiAlN	25,64
1,50	38	4	3	FMD20150	17,53	FMD20150TiAlN	23,24	FMD630150	17,53	FMD630150TiAlN	23,24
1,50	50	4	4	FMD20150X50	18,78	FMD20150X50TiAlN	25,64	FMD630150X50	18,78	FMD630150X50TiAlN	25,64
2,00	38	6	3	FMD20200	17,53	FMD20200TiAlN	23,24	FMD630200	17,53	FMD630200TiAlN	23,24
2,00	50	6	4	FMD20200X50	18,78	FMD20200X50TiAlN	25,64	FMD630200X50	18,78	FMD630200X50TiAlN	25,64
2,50	38	8	3	FMD20250	17,53	FMD20250TiAlN	23,24	FMD630250	17,53	FMD630250TiAlN	23,24
2,50	50	8	4	FMD20250X50	18,78	FMD20250X50TiAlN	25,64	FMD630250X50	18,78	FMD630250X50TiAlN	25,64
3,00	38	8	3	FMD20300	16,82	FMD20300TiAlN	22,53	FMD630300	16,82	FMD630300TiAlN	22,53
3,00	50	8	4	FMD20300X5004	18,49	FMD20300X5004TiAlN	26,51	FMD630300X5004	18,49	FMD630300X5004TiAlN	26,51
3,00	50	8	6	FMD20300X5006	19,85	FMD20300X5006TiAlN	27,71	FMD630300X5006	19,85	FMD630300X5006TiAlN	27,71
3,50	50	11	4	FMD20350	19,66	FMD20350TiAlN	25,37	FMD630350	19,66	FMD630350TiAlN	25,37
4,00	50	11	4	FMD20400	16,71	FMD20400TiAlN	22,42	FMD630400	16,71	FMD630400TiAlN	22,42
4,00	50	11	6	FMD20400X5006	20,36	FMD20400X5006TiAlN	27,80	FMD630400X5006	20,36	FMD630400X5006TiAlN	27,80
4,50	50	11	6	FMD20450	21,54	FMD20450TiAlN	27,25	FMD630450	21,54	FMD630450TiAlN	27,25
5,00	50	13	5	FMD20500	18,98	FMD20500TiAlN	24,69	FMD630500	18,98	FMD630500TiAlN	24,69
5,00	50	13	6	FMD20500X5006	21,08	FMD20500X5006TiAlN	27,98	FMD630500X5006	21,08	FMD630500X5006TiAlN	27,98
5,50	50	16	6	FMD20550	20,76	FMD20550TiAlN	28,01	FMD630550	20,76	FMD630550TiAlN	28,01
6,00	50	16	6	FMD20600	20,77	FMD20600TiAlN	26,48	FMD630600	20,77	FMD630600TiAlN	26,48
6,00	58	22	6	FMD20600X58	22,32	FMD20600X58TiAlN	28,19	FMD630600X58	22,32	FMD630600X58TiAlN	28,19
6,35	60	19	8	FMD20635	24,24	FMD20635TiAlN	30,00	FMD630635	24,24	FMD630635TiAlN	30,00
6,50	60	19	8	FMD20650	27,23	FMD20650TiAlN	34,22	FMD630650	27,23	FMD630650TiAlN	34,22
7,00	60	19	8	FMD20700	33,98	FMD20700TiAlN	40,83	FMD630700	33,98	FMD630700TiAlN	40,83
7,50	60	19	8	FMD20750	33,97	FMD20750TiAlN	40,84	FMD630750	33,97	FMD630750TiAlN	40,84
8,00	60	19	8	FMD20800	30,87	FMD20800TiAlN	37,73	FMD630800	30,87	FMD630800TiAlN	37,73
8,50	72	22	10	FMD20850	35,88	FMD20850TiAlN	42,59	FMD630850	35,88	FMD630850TiAlN	42,59
9,00	72	22	10	FMD20900	37,08	FMD20900TiAlN	43,55	FMD630900	37,08	FMD630900TiAlN	43,55
9,50	72	22	10	FMD20950	49,07	FMD20950TiAlN	58,76	FMD630950	49,07	FMD630950TiAlN	58,76
10,00	72	22	10	FMD21000	46,37	FMD21000TiAlN	54,36	FMD631000	46,37	FMD631000TiAlN	54,36
10,00	80	32	10	FMD21000X80	50,27	FMD21000X80TiAlN	57,72	FMD631000X80	50,27	FMD631000X80TiAlN	57,72
10,50	75	26	12	FMD21050	50,27	FMD21050TiAlN	58,67	FMD631050	50,27	FMD631050TiAlN	58,67
11,00	75	26	12	FMD21100	67,84	FMD21100TiAlN	76,98	FMD631100	67,84	FMD631100TiAlN	76,98
12,00	75	26	12	FMD21200	59,13	FMD21200TiAlN	68,26	FMD631200	59,13	FMD631200TiAlN	68,26
12,50	84	30	14	FMD21250	60,12	FMD21250TiAlN	68,27	FMD631250	60,12	FMD631250TiAlN	68,27
13,00	84	30	14	FMD21300	60,83	FMD21300TiAlN	68,40	FMD631300	60,83	FMD631300TiAlN	68,40
14,00	84	30	14	FMD21400	90,84	FMD21400TiAlN	102,28	FMD631400	90,84	FMD631400TiAlN	102,28
14,00	100	50	14	FMD21400X100	101,15	FMD21400X100TiAlN	113,63	FMD631400X100	101,15	FMD631400X100TiAlN	113,63
15,00	92	32	16	FMD21500	103,92	FMD21500TiAlN	116,40	FMD631500	103,92	FMD631500TiAlN	116,40
16,00	92	32	16	FMD21600	117,37	FMD21600TiAlN	129,94	FMD631600	117,37	FMD631600TiAlN	129,94
16,00	100	50	16	FMD21600X100	126,11	FMD21600X100TiAlN	139,55	FMD631600X100	126,11	FMD631600X100TiAlN	139,55
17,00	100	38	18	FMD21700	119,39	FMD21700TiAlN	133,40	FMD631700	119,39	FMD631700TiAlN	133,40
18,00	100	38	18	FMD21800	171,97	FMD21800TiAlN	189,12	FMD631800	171,97	FMD631800TiAlN	189,12
18,00	100	50	18	FMD21800X10050	188,51	FMD21800X10050TiAlN	207,71	FMD631800X10050	188,51	FMD631800X10050TiAlN	207,71
19,00	100	38	20	FMD21900	193,31	FMD21900TiAlN	212,51	FMD631900	193,31	FMD631900TiAlN	212,51
20,00	100	38	20	FMD22000	195,61	FMD22000TiAlN	217,32	FMD632000	195,61	FMD632000TiAlN	217,32
20,00	100	50	20	FMD22000X10050	206,75	FMD22000X10050TiAlN	228,83	FMD632000X10050	206,75	FMD632000X10050TiAlN	228,83
22,00	100	38	22	FMD22200	277,79	FMD22200TiAlN	312,35	FMD632200	277,79	FMD632200TiAlN	312,35
25,00	100	45	25	FMD22500	339,43	FMD22500TiAlN	372,57	FMD632500	339,43	FMD632500TiAlN	372,57
25,00	110	55	25	FMD22500X110	373,79	FMD22500X110TiAlN	418,91	FMD632500X110	373,79	FMD632500X110TiAlN	418,91



FMD2 FMD63



**44  
HRC**



FRAISES CARBURE POUR APPLICATIONS GÉNÉRALES SÉRIE COURTE

USAGE  
GÉNÉRAL

CARBURE



CYLINDRIQUE

4 Z



TOL D1  
+0 -0,05

TOL D2  
h6

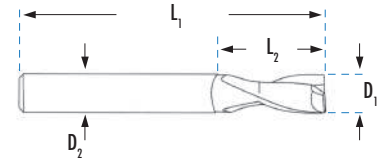

SÉRIE COURTE

MATÉRIEL				FMD48		FMD48TL	
FINITION				CARBURE		CARBURE	
QUALITÉ				BRILLANT		TiAlN	
				★★		★★★	
				4Z		4Z	
D1 mm	L1 mm	L2 mm	D2 mm	€	€	€	€
1,00	38	3	3	FMD480100	17,53	FMD480100TIALN	23,24
1,00	50	3	4	FMD480100X50	18,78	FMD480100X50TIALN	25,64
1,50	38	4	3	FMD480150	17,53	FMD480150TIALN	23,24
1,50	50	4	4	FMD480150X50	18,78	FMD480150X50TIALN	25,64
2,00	38	6	3	FMD480200	17,53	FMD480200TIALN	23,24
2,00	50	6	4	FMD480200X50	18,78	FMD480200X50TIALN	25,64
2,50	38	8	3	FMD480250	17,53	FMD480250TIALN	23,24
2,50	50	8	4	FMD480250X50	18,78	FMD480250X50TIALN	25,64
3,00	38	8	3	FMD480300	16,82	FMD480300TIALN	22,53
3,00	50	8	4	FMD480300X5004	18,49	FMD480300X5004TIALN	26,51
3,00	50	8	6	FMD480300X5006	19,85	FMD480300X5006TIALN	27,71
3,50	50	11	4	FMD480350	19,66	FMD480350TIALN	25,37
4,00	50	11	4	FMD480400	16,71	FMD480400TIALN	22,42
4,00	50	11	6	FMD480400X5006	20,36	FMD480400X5006TIALN	27,80
4,50	50	11	6	FMD480450	21,54	FMD480450TIALN	27,25
5,00	50	13	5	FMD480500	18,98	FMD480500TIALN	24,69
5,00	50	13	6	FMD480500X5006	21,08	FMD480500X5006TIALN	27,98
5,50	50	16	6	FMD480550	20,76	FMD480550TIALN	28,01
6,00	50	16	6	FMD480600	20,77	FMD480600TIALN	26,48
6,00	58	22	6	FMD480600X58	22,32	FMD480600X58TIALN	28,19
6,35	60	19	8	FMD480635	24,24	FMD480635TIALN	30,00
6,50	60	19	8	FMD480650	27,23	FMD480650TIALN	34,22
7,00	60	19	8	FMD480700	33,98	FMD480700TIALN	40,83
7,50	60	19	8	FMD480750	33,97	FMD480750TIALN	40,84
8,00	60	19	8	FMD480800	30,87	FMD480800TIALN	37,73
8,50	72	22	10	FMD480850	35,88	FMD480850TIALN	42,59
9,00	72	22	10	FMD480900	37,08	FMD480900TIALN	43,55
9,50	72	22	10	FMD480950	49,07	FMD480950TIALN	58,76
10,00	72	22	10	FMD481000	46,37	FMD481000TIALN	54,36
10,00	80	32	10	FMD481000X80	50,27	FMD481000X80TIALN	57,72
10,50	75	26	12	FMD481050	50,27	FMD481050TIALN	58,67
11,00	75	26	12	FMD481100	67,84	FMD481100TIALN	76,98
12,00	75	26	12	FMD481200	59,13	FMD481200TIALN	68,26
12,50	84	30	14	FMD481250	60,12	FMD481250TIALN	68,27
13,00	84	30	14	FMD481300	60,83	FMD481300TIALN	68,40
14,00	84	30	14	FMD481400	90,84	FMD481400TIALN	102,28
14,00	100	50	14	FMD481400X100	101,15	FMD481400X100TIALN	113,63
15,00	92	32	16	FMD481500	103,92	FMD481500TIALN	116,40
16,00	92	32	16	FMD481600	117,37	FMD481600TIALN	129,94
16,00	100	50	16	FMD481600X100	126,11	FMD481600X100TIALN	139,55
17,00	100	38	18	FMD481700	119,39	FMD481700TIALN	133,40
18,00	100	38	18	FMD481800	171,97	FMD481800TIALN	189,12
18,00	100	50	18	FMD481800X10050	188,51	FMD481800X10050TIALN	207,71
19,00	100	38	20	FMD481900	193,31	FMD481900TIALN	212,51
20,00	100	38	20	FMD482000	195,61	FMD482000TIALN	217,32
20,00	100	50	20	FMD482000X10050	206,75	FMD482000X10050TIALN	228,83
22,00	100	38	22	FMD482200	277,79	FMD482200TIALN	312,35
25,00	100	45	25	FMD482500	339,43	FMD482500TIALN	372,57
25,00	110	55	25	FMD482500X110	373,79	FMD482500X110TIALN	418,91



FMD48 FMD48TL



44  
HRC

**FRAISES CARBURE POUR APPLICATIONS GÉNÉRALES SÉRIE LONGUE**
**USAGE  
GÉNÉRAL**
**CARBURE**

**CYLINDRIQUE**
**2Z**

**3Z**

**4Z**

**SÉRIE LONGUE**

MATÉRIEL				FMD54		FMD54TL		FMD73		FMD73TL	
FINITION				CARBURE	CARBURE	CARBURE	CARBURE	CARBURE	CARBURE	CARBURE	
QUALITÉ				BRILLANT	BRILLANT	BRILLANT	BRILLANT	BRILLANT	BRILLANT	BRILLANT	
				★★	★★	★★★	★★	★★	★★	★★	
				2Z	2Z	2Z	3Z	3Z	3Z	3Z	
D1 mm	L1 mm	L2 mm	D2 mm	€	€	€	€	€	€	€	
1,00	60	5	3	FMD540100	18,41	FMD540100TIALN	25,55	FMD730100	18,41	FMD730100TIALN	25,55
2,00	60	10	3	FMD540200	18,89	FMD540200TIALN	26,03	FMD730200	18,89	FMD730200TIALN	26,03
3,00	60	15	3	FMD540300	19,40	FMD540300TIALN	26,54	FMD730300	19,40	FMD730300TIALN	26,54
4,00	80	20	4	FMD540400	20,45	FMD540400TIALN	27,58	FMD730400	20,45	FMD730400TIALN	27,58
5,00	80	25	5	FMD540500	25,45	FMD540500TIALN	32,59	FMD730500	25,45	FMD730500TIALN	32,59
6,00	80	25	6	FMD540600	35,89	FMD540600TIALN	43,02	FMD730600	35,89	FMD730600TIALN	43,02
7,00	90	35	8	FMD540700	37,85	FMD540700TIALN	47,69	FMD730700	37,85	FMD730700TIALN	47,69
8,00	90	35	8	FMD540800	40,86	FMD540800TIALN	50,39	FMD730800	40,86	FMD730800TIALN	50,39
9,00	100	45	10	FMD540900	53,36	FMD540900TIALN	64,25	FMD730900	53,36	FMD730900TIALN	64,25
10,00	100	45	10	FMD541000	57,74	FMD541000TIALN	67,27	FMD731000	57,74	FMD731000TIALN	67,27
12,00	100	50	12	FMD541200	78,82	FMD541200TIALN	90,73	FMD731200	78,82	FMD731200TIALN	90,73
14,00	150	65	14	FMD541400	129,70	FMD541400TIALN	145,17	FMD731400	129,70	FMD731400TIALN	145,17
16,00	150	65	16	FMD541600	142,10	FMD541600TIALN	157,57	FMD731600	142,10	FMD731600TIALN	157,57
16,00	150	90	16	FMD541600X15090	156,30	FMD541600X15090TIALN	173,33	FMD731600X15090	156,30	FMD731600X15090TIALN	173,33
20,00	150	70	20	FMD542000	252,06	FMD542000TIALN	275,88	FMD732000	252,06	FMD732000TIALN	275,88
25,00	150	75	25	FMD542500	496,36	FMD542500TIALN	523,31	FMD732500	496,36	FMD732500TIALN	523,31

**FMD54 FMD73**

**SÉRIE LONGUE**

MATÉRIEL				FMD58		FMD58TL	
FINITION				CARBURE	CARBURE	CARBURE	CARBURE
QUALITÉ				BRILLANT	BRILLANT	BRILLANT	BRILLANT
				★★	★★	★★★	★★★
				4Z	4Z	4Z	4Z
D1 mm	L1 mm	L2 mm	D2 mm	€	€	€	€
1,00	60	5	3	FMD580100	18,41	FMD580100TIALN	25,55
2,00	60	10	3	FMD580200	18,89	FMD580200TIALN	26,03
3,00	60	15	3	FMD580300	19,40	FMD580300TIALN	26,54
4,00	80	20	4	FMD580400	20,45	FMD580400TIALN	27,58
5,00	80	25	5	FMD580500	25,45	FMD580500TIALN	32,59
6,00	80	25	6	FMD580600	35,89	FMD580600TIALN	43,02
7,00	90	35	8	FMD580700	37,85	FMD580700TIALN	47,69
8,00	90	35	8	FMD580800	40,86	FMD580800TIALN	50,39
9,00	100	45	10	FMD580900	53,36	FMD580900TIALN	64,25
10,00	100	45	10	FMD581000	57,74	FMD581000TIALN	67,27
12,00	100	50	12	FMD581200	78,82	FMD581200TIALN	90,73
14,00	150	65	14	FMD581400	129,70	FMD581400TIALN	145,17
16,00	150	65	16	FMD581600	142,10	FMD581600TIALN	157,57
16,00	150	90	16	FMD581600X15090	156,30	FMD581600X15090TIALN	173,33
20,00	150	70	20	FMD582000	252,06	FMD582000TIALN	275,88
25,00	150	75	25	FMD582500	496,36	FMD582500TIALN	523,31

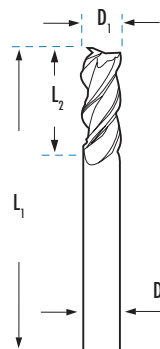
**FMD58 FMD58TL**

**FRAISES CARBURE POUR APPLICATIONS GÉNÉRALES SÉRIE EXTRA-LONGUE**

**USAGE  
GÉNÉRAL**

**CARBURE**



**30°  
N**



**CYLINDRIQUE**

**2Z**



**4Z**

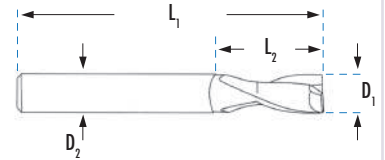

**SÉRIE EXTRA-LONGUE**

MATÉRIEL				FMD53		FMD53TL		FMD56		FMD56TL	
FINITION				CARBURE		CARBURE		CARBURE		CARBURE	
QUALITÉ				BRILLANT		TiAlN		BRILLANT		TiAlN	
				★★		★★★		★★		★★★	
				2Z		2Z		4Z		4Z	
Ø mm	L1 mm	L2 mm	D2 mm	€	€	€	€	€	€	€	€
3,00	75	25	3	FMD530300	41,71	FMD530300TIALN	53,62	FMD560300	43,16	FMD560300TIALN	55,07
3,00	100	25	3	FMD530300X100	44,46	FMD530300X100TIALN	56,54	FMD560300X100	45,66	FMD560300X100TIALN	57,36
4,00	100	25	4	FMD530400	45,32	FMD530400TIALN	57,23	FMD560400	46,74	FMD560400TIALN	58,65
5,00	100	25	5	FMD530500	51,22	FMD530500TIALN	63,13	FMD560500	53,82	FMD560500TIALN	65,73
6,00	100	25	6	FMD530600X10025	77,25	FMD530600X10025TIALN	96,96	FMD560600X10025	79,57	FMD560600X10025TIALN	99,87
6,00	100	40	6	FMD530600X10040	78,85	FMD530600X10040TIALN	98,11	FMD560600X10040	81,22	FMD560600X10040TIALN	101,05
6,00	150	25	6	FMD530600X15025	80,80	FMD530600X15025TIALN	99,36	FMD560600X15025	83,22	FMD560600X15025TIALN	102,34
6,00	150	40	6	FMD530600X15040	83,36	FMD530600X15040TIALN	102,25	FMD560600X15040	85,86	FMD560600X15040TIALN	105,32
6,00	150	75	6	FMD530600	85,49	FMD530600TIALN	104,54	FMD560600	90,42	FMD560600TIALN	108,73
8,00	100	45	8	FMD530800X10045	106,33	FMD530800X10045TIALN	132,36	FMD560800X10045	109,52	FMD560800X10045TIALN	136,33
8,00	150	25	8	FMD530800X15025	111,11	FMD530800X15025TIALN	135,37	FMD560800X15025	114,44	FMD560800X15025TIALN	139,43
8,00	150	45	8	FMD530800X15045	114,45	FMD530800X15045TIALN	137,89	FMD560800X15045	117,88	FMD560800X15045TIALN	142,03
8,00	150	75	8	FMD530800	117,71	FMD530800TIALN	140,34	FMD560800	124,50	FMD560800TIALN	146,25
10,00	150	38	10	FMD531000X15038	137,36	FMD531000X15038TIALN	169,69	FMD561000X15038	141,48	FMD561000X15038TIALN	174,78
10,00	150	50	10	FMD531000X15050	141,41	FMD531000X15050TIALN	172,25	FMD561000X15050	145,65	FMD561000X15050TIALN	177,42
10,00	150	65	10	FMD531000X15065	145,36	FMD531000X15065TIALN	175,75	FMD561000X15065	149,72	FMD561000X15065TIALN	181,02
10,00	150	75	10	FMD531000	149,10	FMD531000TIALN	178,87	FMD561000	164,01	FMD561000TIALN	193,77
12,00	150	38	12	FMD531200X15038	199,96	FMD531200X15038TIALN	241,14	FMD561200X15038	205,96	FMD561200X15038TIALN	248,37
12,00	150	50	12	FMD531200X15050	205,36	FMD531200X15050TIALN	247,47	FMD561200X15050	211,52	FMD561200X15050TIALN	254,89
12,00	150	75	12	FMD531200	218,16	FMD531200TIALN	256,26	FMD561200	239,97	FMD561200TIALN	278,08
12,00	200	38	12	FMD531200X20038	231,25	FMD531200X20038TIALN	272,36	FMD561200X20038	258,36	FMD561200X20038TIALN	281,11
14,00	150	75	14	FMD531400	301,59	FMD531400TIALN	348,03	FMD561400	331,75	FMD561400TIALN	378,19
16,00	200	75	16	FMD531600	409,75	FMD531600TIALN	463,33	FMD561600	450,73	FMD561600TIALN	504,31
20,00	200	75	20	FMD532000	639,35	FMD532000TIALN	710,79	FMD562000	639,35	FMD562000TIALN	710,79



**FMD53 FMD56**



Fraises

Rose

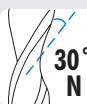
**FRAISES HÉMISPÉRIQUES CARBURE POUR APPLICATIONS GÉNÉRALES SÉRIE COURTE ET LONGUE**
**USAGE  
GÉNÉRAL**
**CARBURE**

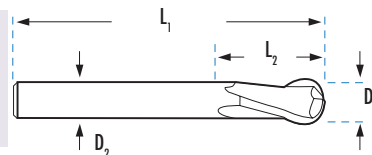
**30°  
N**
**CYLINDRIQUE**
**2Z**

**4Z**

**SÉRIE COURTE**

MATÉRIEL				FMD92		FMD92TL		FMD51		FMD51TL	
FINITION				CARBURE	CARBURE	CARBURE	CARBURE	CARBURE	CARBURE	CARBURE	
QUALITÉ				BRILLANT	BRILLANT	TiAlN	BRILLANT	BRILLANT	TiAlN		
				★★	★★★	★★★	★★	★★	★★★		
				2Z	2Z	2Z	4Z	4Z	4Z		
D1 mm	L1 mm	L2 mm	D2 mm	€	€	€	€	€	€		
1,00	38	2	3	FMD920100	21,91	FMD920100TIALN	27,86	FMD510100	FMD510100TIALN		
1,00	50	2	4	FMD920100X50	26,56	FMD920100X50TIALN	34,12	FMD510100X50	FMD510100X50TIALN		
1,50	38	3	3	FMD920150	21,91	FMD920150TIALN	27,86	FMD510150	FMD510150TIALN		
1,50	50	3	4	FMD920150X50	26,56	FMD920150X50TIALN	34,12	FMD510150X50	FMD510150X50TIALN		
2,00	38	4	3	FMD920200	21,91	FMD920200TIALN	27,86	FMD510200	FMD510200TIALN		
2,00	50	4	4	FMD920200X50	26,56	FMD920200X50TIALN	34,12	FMD510200X50	FMD510200X50TIALN		
2,50	38	5	3	FMD920250	21,91	FMD920250TIALN	27,86	FMD510250X50	FMD510250X50TIALN		
3,00	38	6	3	FMD920300	21,91	FMD920300TIALN	27,86	FMD510300	FMD510300TIALN	30,65	
3,00	50	6	4	FMD920300X50	26,56	FMD920300X50TIALN	34,12	FMD510300X50	FMD510300X50TIALN		
4,00	50	8	4	FMD920400	24,97	FMD920400TIALN	30,92	FMD510400	FMD510400TIALN	34,01	
5,00	50	10	5	FMD920500	26,42	FMD920500TIALN	32,38	FMD510500	FMD510500TIALN	35,61	
6,00	50	12	6	FMD920600	31,09	FMD920600TIALN	37,04	FMD510600	FMD510600TIALN	40,75	
7,00	60	15	8	FMD920700	37,85*	FMD920700TIALN	44,25	FMD510700	FMD510700TIALN	47,96	
8,00	60	15	8	FMD920800	38,38	FMD920800TIALN	45,52	FMD510800	FMD510800TIALN	56,91	
10,00	75	20	10	FMD921000	57,67	FMD921000TIALN	66,00	FMD511000	FMD511000TIALN	82,50	
12,00	75	20	12	FMD921200	71,65	FMD921200TIALN	81,17	FMD511200	FMD511200TIALN	101,46	
14,00	90	25	14	FMD921400	106,06	FMD921400TIALN	117,97	FMD511400	FMD511400TIALN	147,46	
16,00	100	25	16	FMD921600	134,19	FMD921600TIALN	147,28	FMD511600	FMD511600TIALN	184,11	
18,00	100	30	18	FMD921800	199,51	FMD921800TIALN	217,37	FMD511800	FMD511800TIALN	271,72	
20,00	100	30	20	FMD922000	206,84	FMD922000TIALN	229,46	FMD512000	FMD512000TIALN	286,82	

**TOL D1  
+0 -0,05**
**TOL D2  
h6**

**FMD92 FMD51**

\*Jusqu'à fin des stocks

**SÉRIE LONGUE**

MATÉRIEL				FMD57		FMD57TL	
FINITION				CARBURE	CARBURE	CARBURE	
QUALITÉ				BRILLANT	BRILLANT	TiAlN	
				★★	★★★	★★★	
				2Z	2Z	2Z	
D1 mm	L1 mm	L2 mm	D2 mm	€	€	€	
1,00	60	2	3	FMD570100	33,03	FMD570100TIALN	40,18
1,50	60	3	3	FMD570150	33,03	FMD570150TIALN	40,18
2,00	60	3	3	FMD570200	33,03	FMD570200TIALN	40,18
2,50	60	3	3	FMD570250	33,03	FMD570250TIALN	40,18
3,00	60	4	3	FMD570300	33,03	FMD570300TIALN	40,18
4,00	80	5	4	FMD570400	38,34	FMD570400TIALN	45,49
5,00	80	6	5	FMD570500	45,35	FMD570500TIALN	52,50
6,00	80	8	6	FMD570600	53,01	FMD570600TIALN	60,14
8,00	100	12	8	FMD570800	69,96	FMD570800TIALN	79,49
10,00	100	15	10	FMD571000	86,44	FMD571000TIALN	97,16
12,00	100	15	12	FMD571200	149,80	FMD571200TIALN	161,71
14,00	150	20	14	FMD571400	187,83	FMD571400TIALN	203,32
16,00	150	20	16	FMD571600	237,24	FMD571600TIALN	252,72
20,00	150	25	20	FMD572000	489,69	FMD572000TIALN	513,50

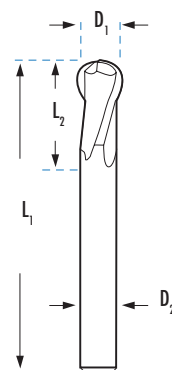
**FMD57 FMD57TL**

**FRAISES HÉMISPÉRIQUES CARBURE POUR APPLICATIONS GÉNÉRALES SÉRIE EXTRA-LONGUE**

**USAGE GÉNÉRAL**

**CARBURE**



30°  
N

CYLINDRIQUE

**2Z**

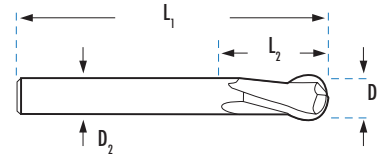

**SÉRIE EXTRA-LONGUE**

MATÉRIEL				FMD55		FMD55TL	
FINITION				CARBURE		CARBURE	
QUALITÉ				BRILLANT		TiAlN	
				★★		★★★	
				2Z		2Z	
D1 mm	L1 mm	L2 mm	D2 mm	€	€	€	€
3,00	75	6	3	FMD550300	39,59	FMD550300TIALN	51,50
3,00	100	6	3	FMD550300X100	42,42	FMD550300X100TIALN	55,36
4,00	100	6	4	FMD550400	45,67	FMD550400TIALN	57,57
5,00	100	6	5	FMD550500	55,19	FMD550500TIALN	67,10
6,00	100	15	6	FMD550600	69,36	FMD550600TIALN	81,27
6,00	150	15	6	FMD550600X150	81,81	FMD550600X150TIALN	96,31
6,00	200	30	6	FMD550600X200	96,36	FMD550600X200TIALN	109,12
8,00	150	25	8	FMD550800	93,17	FMD550800TIALN	111,03
8,00	200	50	8	FMD550800X200	112,12	FMD550800X200TIALN	132,11
10,00	150	25	10	FMD551000	131,27	FMD551000TIALN	149,13
10,00	200	50	10	FMD551000X200	149,99	FMD551000X200TIALN	171,71
12,00	150	25	12	FMD551200	208,78	FMD551200TIALN	242,11
12,00	200	25	12	FMD551200X200	256,36	FMD551200X200TIALN	294,22
14,00	200	50	14	FMD551400	256,40	FMD551400TIALN	294,51
16,00	200	50	16	FMD551600	344,51	FMD551600TIALN	386,18



FMD55 FMD55TL



**44 HRc**

**CONDITIONS DE COUPE INDICATIVES**

		Ø2	Ø3	Ø4	Ø5	Ø6	Ø8	Ø10	Ø12	Ø14
	RPM	4000	2600	2000	1600	1300	1000	800	660	570
	AVANCE (mm/min)	50	55	55	55	55	55	55	55	55
<b>INOX</b> Ti	RPM	8000	5300	4000	3200	2600	2000	1600	1300	1100
	AVANCE (mm/min)	55	55	55	55	60	60	60	60	60
<b>Al</b>	RPM	16000	11000	8000	6400	5300	4000	3200	2600	2300
	AVANCE (mm/min)	290	290	290	290	290	290	290	290	300

\* Pour obtenir les conditions de coupe pour les fraises revêtues en TiAlN, multiplier les valeurs du tableau par 1,3

**FRAISES CARBURE HAUTES PERFORMANCES**
**USAGE GÉNÉRAL**
**CARBURE**

**2Z**

**3Z**

**4Z**

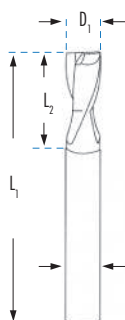
**HAUTE PERFORMANCE**
**Micro Grain CARBURE**
**SÉRIE COURTE**

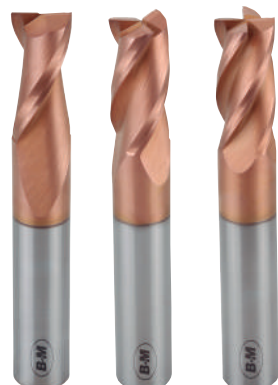
**TOL D1**  
 +0 -0,05

**TOL D2**  
 h6

**HÉLICE VARIABLE**

**FMT2**
**FMT63**
**FMT48**
**FMT81**
**FMT92**
**MATÉRIEL**  
**FINITION**  
**QUALITÉ**

**CARBURE**
**CARBURE**
**CARBURE**
**CARBURE**
**CARBURE**
**TiAlSiN**
**TiAlSiN**
**TiAlSiN**
**TiAlSiN**
**TiAlSiN**
**2Z**
**3Z**
**4Z**
**4Z**
**2Z**

D1 mm	L1 mm	L2 mm	D2 mm	€	€	€
1,00	38	3	3	45,85	45,85	45,85
1,50	38	4	3	44,77	44,77	44,77
2,00	38	6	3	35,63	35,63	35,63
2,50	38	8	3	34,82	34,82	34,82
3,00	38	8	3	29,99	29,99	29,99
3,50	50	11	4	36,81	36,81	36,81
4,00	50	11	4	34,20	34,20	34,20
4,50	50	13	5	43,74	43,74	43,74
5,00	50	13	5	43,21	43,21	43,21
6,00	50	16	6	48,71	48,71	48,71
7,00	60	16	8	67,94	67,94	67,94
8,00	60	19	8	57,66	57,66	57,66
9,00	72	19	10	82,67	82,67	82,67
10,00	72	22	10	91,92	91,92	91,92
11,00	75	26	12	122,27	122,27	122,27
12,00	75	26	12	113,69	113,69	113,69
14,00	84	30	14	169,00	169,00	169,00
16,00	92	32	16	218,92	218,92	218,92
18,00	100	38	18	304,21	304,21	304,21
20,00	100	38	20	346,83	346,83	346,83
25,00	100	38	25	569,30	569,30	569,30

D1 mm	L1 mm	L2 mm	D2 mm	€
1,00	38	3	3	
1,50	38	5	3	
2,00	38	6	3	
2,50	38	7	3	
3,00	38	12	3	
3,50	50	12	4	
4,00	50	14	4	
4,50	50	14	5	
5,00	50	16	5	47,54
6,00	63	19	6	53,59
7,00	63	19	8	
8,00	63	19	8	63,42
9,00	70	22	10	
10,00	70	22	10	101,10
11,00	75	25	11	
12,00	75	25	12	125,05
14,00	88	30	14	185,89
16,00	88	32	16	240,81
18,00	100	36	18	334,62
20,00	100	36	20	381,51
25,00	100	38	25	

D1 mm	L1 mm	L2 mm	D2 mm	€
1,00	38	2	3	
1,50	38	3	3	
2,00	38	4	3	
2,50	38	5	3	
3,00	38	6	3	39,59
4,00	50	8	4	43,92
5,00	50	10	5	54,29
6,00	50	12	6	62,11
8,00	60	15	8	76,36
10,00	75	20	10	110,69
12,00	75	20	12	136,13
14,00	90	25	14	197,84
16,00	100	25	16	247,01
18,00	100	30	18	364,56
20,00	100	30	20	384,81

\* **FMT81**: Fraise 4 lèvres, coupe au centre, hélice variable, revêtement TiAlSiN. La double hélice réduit les vibrations et permet, conjointement avec le revêtement TiAlSiN, un rendement extrêmement élevé.

**CONDITIONS DE COUPE INDICATIVES**

		Ø 2	Ø 3	Ø 4	Ø 5	Ø 6	Ø 8	Ø 10	Ø 12	Ø 14	Ø 16	Ø 20	Ø 25
	RPM	5600	3640	2800	2240	1820	1400	1120	924	798	700	560	420
	AVANCE (mm/min)	70	77	77	77	77	77	77	77	77	91	91	70
<b>INOX</b> <b>Ti</b>	RPM	11200	7420	5600	4480	3640	2800	2240	1820	1540	1400	1120	840
	AVANCE (mm/min)	77	77	77	77	84	84	84	84	84	98	98	77
<b>Ni</b>	RPM	11200	7420	5600	4480	3640	2800	2240	1820	1540	1400	1120	840
	AVANCE (mm/min)	77	77	77	77	84	84	84	84	84	98	98	77

**FRAISES TORIQUES CARBURE**

**NEW**  
Réf. FMG10R  
Réf. FMG54R

**USAGE GÉNÉRAL TORIQUES**

CARBURE



CYLINDRIQUE

TiAIN

2Z



4Z



Micro Grain CARBURE

Fraises

Rose

					FMG10R		FMG54R	
MATÉRIEL					CARBURE	CARBURE	CARBURE	CARBURE
FINITION					TiAIN	TiAIN	TiAIN	TiAIN
QUALITÉ					★★	★★★	★★★	★★★
					2Z	4Z	4Z	4Z
D1 mm	D2 mm	R mm	L2 mm	L1 mm	€	€	€	€
2	6	0,2	6	50	FMG100200R0,2	27,39	FMG540200R0,2	27,39
2	6	0,5	6	50	FMG100200R0,5	27,39	FMG540200R0,5	27,39
3	6	0,2	8	50	FMG100300R0,2	27,39	FMG540300R0,2	27,39
3	6	0,5	8	50	FMG100300R0,5	27,39	FMG540300R0,5	27,39
4	6	0,2	11	50	FMG100400R0,2	27,39	FMG540400R0,2	27,39
4	6	0,5	11	50	FMG100400R0,5	27,39	FMG540400R0,5	27,39
4	6	1,0	11	50	FMG100400R1	27,39	FMG540400R1	27,39
5	6	0,2	12	50	FMG100500R0,2	27,39	FMG540500R0,2	27,39
5	6	0,5	12	50	FMG100500R0,5	27,39	FMG540500R0,5	27,39
5	6	1,0	12	50	FMG100500R1	27,39	FMG540500R1	27,39
6	6	0,2	12	50	FMG100600R0,2	27,39	FMG540600R0,2	27,39
6	6	0,5	13	50	FMG100600R0,5	27,39	FMG540600R0,5	27,39
6	6	1,0	13	50	FMG100600R1	27,39	FMG540600R1	27,39
6	6	1,5	13	50	FMG100600R1,5	27,39	FMG540600R1,5	27,39
6	6	2,0	13	50	FMG100600R2	27,39	FMG540600R2	27,39
8	8	0,2	15	60	FMG100800R0,2	37,70	FMG540800R0,2	37,70
8	8	0,5	15	60	FMG100800R0,5	37,70	FMG540800R0,5	37,70
8	8	1,0	15	60	FMG100800R1	37,70	FMG540800R1	37,70
8	8	1,5	15	60	FMG100800R1,5	37,70	FMG540800R1,5	37,70
8	8	2,0	15	60	FMG100800R2	37,70	FMG540800R2	37,70
10	10	0,5	20	72	FMG101000R0,5	51,91	FMG541000R0,5	51,91
10	10	1,0	20	72	FMG101000R1	51,91	FMG541000R1	51,91
10	10	1,5	20	72	FMG101000R1,5	51,91	FMG541000R1,5	51,91
10	10	2,0	20	72	FMG101000R2	51,91	FMG541000R2	51,91
10	10	3,0	20	72	FMG101000R3	51,91	FMG541000R3	51,91
12	12	0,5	24	75	FMG101200R0,5	73,32	FMG541200R0,5	73,32
12	12	1,0	24	75	FMG101200R1	73,32	FMG541200R1	73,32
12	12	1,5	24	75	FMG101200R1,5	73,32	FMG541200R1,5	73,32
12	12	2,0	24	75	FMG101200R2	73,32	FMG541200R2	73,32
12	12	3,0	24	75	FMG101200R3	73,32	FMG541200R3	73,32
16	16	0,5	30	92	FMG101600R0,5	137,63	FMG541600R0,5	137,63
16	16	1,0	30	92	FMG101600R1	137,63	FMG541600R1	137,63
16	16	2,0	30	92	FMG101600R2	137,63	FMG541600R2	137,63
16	16	3,0	30	92	FMG101600R3	137,63	FMG541600R3	137,63
16	16	4,0	30	92	FMG101600R4	137,63	FMG541600R4	137,63

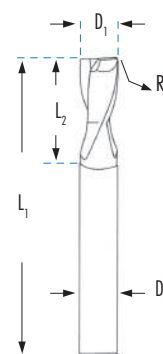

44  
HRc

**FRAISES CARBURE MICROMÉTRIQUES AVEC ET SANS DÉGAGEMENT**

Fraises

NEW

 Réf. FMD22  
 Réf. FMD35

**USAGE  
GÉNÉRAL  
MICRO**

CARBURE

30°  
N

CYLINDRIQUE

TiAlN

2Z

 Micro Grain  
 CARBURE

SANS COU

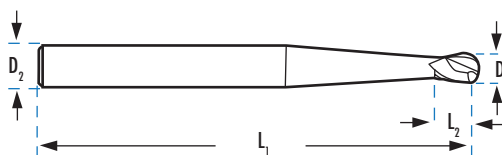
**44  
HRc**

**FRAISES HÉMISPÉRIQUES**

FMD22

FMD35

	TOL -0,015		TOL h6			€
	D <sub>1</sub> mm	D <sub>2</sub> mm	L <sub>2</sub> mm	L <sub>1</sub> mm		
FMD220020X04	0,2	4	0,4	50	38,57	
FMD220030X06	0,3	4	0,6	50	36,78	
FMD220040X08	0,4	4	0,8	50	34,41	
FMD220050X10	0,5	4	1,0	50	32,50	
FMD220060X12	0,6	4	1,2	50	32,50	
FMD220070X14	0,7	4	1,4	50	32,50	
FMD220080X16	0,8	4	1,6	50	32,50	
FMD220090X18	0,9	4	1,8	50	32,50	



	TOL -0,015		TOL h6			€
	D <sub>1</sub> mm	D <sub>2</sub> mm	L <sub>2</sub> mm	L <sub>1</sub> mm		
FMD350020X04	0,2	4	0,4	50	48,45	
FMD350030X06	0,3	4	0,6	50	44,63	
FMD350040X08	0,4	4	0,8	50	39,09	
FMD350050X10	0,5	4	1,0	50	37,21	
FMD350060X12	0,6	4	1,2	50	37,21	
FMD350070X14	0,7	4	1,4	50	37,21	
FMD350080X16	0,8	4	1,6	50	37,21	
FMD350090X18	0,9	4	1,8	50	37,21	

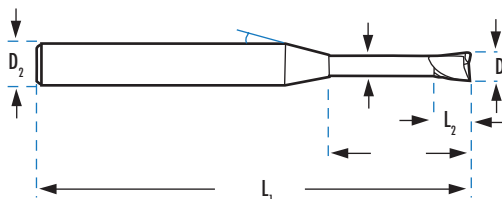

AVEC COU

**44  
HRc**

**FRAISES HÉMISPÉRIQUES**

FMD22

FMD35

	TOL -0,015		TOL h6				€
	D <sub>1</sub> mm	D <sub>2</sub> mm	D <sub>3</sub> mm	L <sub>3</sub> mm	L <sub>2</sub> mm	L <sub>1</sub> mm	
FMD220050X04	0,5	4	0,48	4	0,7	50	34,58
FMD220500X06	0,5	4	0,48	6	0,7	50	34,58
FMD220060X04	0,6	4	0,57	4	0,9	50	34,58
FMD220060X06	0,6	4	0,57	6	0,9	50	34,58
FMD220060X08	0,6	4	0,57	8	0,9	50	34,58
FMD220080X06	0,8	4	0,76	6	1,2	50	34,58
FMD220080X08	0,8	4	0,76	8	1,2	50	34,58
FMD220080X10	0,8	4	0,76	10	1,2	50	34,58
FMD220120X06	1,2	4	1,15	6	1,8	50	23,40
FMD220120X08	1,2	4	1,15	8	1,8	50	23,40
FMD220120X10	1,2	4	1,15	10	1,8	50	23,40



	TOL -0,015		TOL h6				€
	D <sub>1</sub> mm	D <sub>2</sub> mm	D <sub>3</sub> mm	L <sub>3</sub> mm	L <sub>2</sub> mm	L <sub>1</sub> mm	
FMD350050X04	0,5	4	0,48	4	0,7	50	41,86
FMD350050X06	0,5	4	0,48	6	0,7	50	41,86
FMD350060X04	0,6	4	0,57	4	0,9	50	41,86
FMD350060X06	0,6	4	0,57	6	0,9	50	41,86
FMD350060X08	0,6	4	0,57	8	0,9	50	41,86
FMD350080X06	0,8	4	0,76	6	1,2	50	41,86
FMD350080X08	0,8	4	0,76	8	1,2	50	41,86
FMD350080X10	0,8	4	0,76	10	1,2	50	41,86
FMD350120X06	1,2	4	1,15	6	1,8	50	24,44
FMD350120X08	1,2	4	1,15	8	1,8	50	24,44
FMD350120X10	1,2	4	1,15	10	1,8	50	24,44





FRAISES CARBURE À DÉGAGEMENT

**NEW**  
Réf. FMD22  
Réf. FMD44  
Réf. FMD35

**USAGE GÉNÉRAL MICRO**

CARBURE



30°



CYLINDRIQUE

TiAIN



Ø  
1-5 mm

Micro Grain  
CARBURE

Fraises

Rose

MATÉRIEL							FMD22		FMD44		FMD35	
FINITION							CARBURE	CARBURE	CARBURE	CARBURE	CARBURE	CARBURE
QUALITÉ							TiAIN	TiAIN	TiAIN	TiAIN	TiAIN	TiAIN
							★★	★★★	★★★	★★	★★	★★
							2Z	4Z	4Z	2Z	2Z	2Z
D1	D2	D3	L3	L2	L1		€	€	€	€	€	
1,0	6	0,95	5	1,5	57	FMD220100X05	32,07	FMD440100X05		FMD350100X05	32,85	
1,0	6	0,95	8	1,5	57	FMD220100X08	32,07	FMD440100X08		FMD350100X08	33,80	
1,0	6	0,95	10	1,5	57	FMD220100X10	32,07	FMD440100X10		FMD350100X10	33,80	
1,0	6	0,95	12	1,5	65	FMD220100X12	33,80	FMD440100X12		FMD350100X12	35,36	
1,0	6	0,95	15	1,5	65	FMD220100X15	33,80	FMD440100X15		FMD350100X15	35,36	
1,0	6	0,95	20	1,5	65	FMD220100X20	33,80	FMD440100X20		FMD350100X20	35,36	
1,5	6	1,42	5	2,0	57	FMD220150X05	32,07	FMD440150X05		FMD350150X05	33,80	
1,5	6	1,42	8	2,0	57	FMD220150X08	32,07	FMD440150X08		FMD350150X08	33,80	
1,5	6	1,42	10	2,0	57	FMD220150X10	32,07	FMD440150X10		FMD350150X10	33,80	
1,5	6	1,42	12	2,0	65	FMD220150X12	33,80	FMD440150X12		FMD350150X12	35,36	
1,5	6	1,42	15	2,0	65	FMD220150X15	33,80	FMD440150X15		FMD350150X15	35,36	
1,5	6	1,42	20	2,0	65	FMD220150X20	33,80	FMD440150X20		FMD350150X20	35,36	
1,5	6	1,42	25	2,0	65	FMD220150X25	33,80	FMD440150X25		FMD350150X25	-	
2,0	6	1,92	6	3,0	57	FMD220200X06	32,07	FMD440200X06	32,07	FMD350200X06	33,80	
2,0	6	1,92	8	3,0	57	FMD220200X08	32,07	FMD440200X08	32,07	FMD350200X08	33,80	
2,0	6	1,92	10	3,0	57	FMD220200X10	32,07	FMD440200X10	32,07	FMD350200X10	33,80	
2,0	6	1,92	12	3,0	60	FMD220200X12	32,93	FMD440200X12	32,93	FMD350200X12	33,80	
2,0	6	1,92	14	3,0	65	FMD220200X14	33,80	FMD440200X14	33,80	FMD350200X14	33,80	
2,0	6	1,92	16	3,0	65	FMD220200X16	33,80	FMD440200X16	33,80	FMD350200X16	34,63	
2,0	6	1,92	20	3,0	65	FMD220200X20	33,80	FMD440200X20	33,80	FMD350200X20	34,63	
2,0	6	1,92	25	3,0	65	FMD220200X25	33,80	FMD440200X25	33,80	FMD350200X25	34,63	
2,0	6	1,92	30	3,0	80	FMD220200X30	41,08	FMD440200X30	41,08	FMD350200X30	42,55	
2,0	6	1,92	35	2,0	80	FMD220200X35	41,08	FMD440200X35	41,08	FMD350200X35	42,55	
2,0	6	1,92	40	3,0	80	FMD220200X40	41,08	FMD440200X40	41,08	FMD350200X40	42,90	
2,0	6	1,92	50	3,0	100	FMD220200X50	44,20	FMD440200X50	44,20	FMD350200X50	46,77	
2,5	6	2,40	10	4,0	57	FMD220250X10	32,07	FMD440250X10	32,07	FMD350250X10	-	
2,5	6	2,40	16	4,0	65	FMD220250X16	33,80	FMD440250X16	33,80	FMD350250X16	-	
2,5	6	2,40	20	4,0	65	FMD220250X20	33,80	FMD440250X20	33,80	FMD350250X20	34,63	
2,5	6	2,40	30	4,0	80	FMD220250X30	41,08	FMD440250X30	41,08	FMD350250X30	42,90	
2,5	6	2,40	40	4,0	80	FMD220250X40	41,08	FMD440250X40	41,08	FMD350250X40	42,90	
3,0	6	2,90	9	5,0	57	FMD220300X09	32,07	FMD440300X09	32,07	FMD350300X09	34,63	
3,0	6	2,90	12	5,0	60	FMD220300X12	32,93	FMD440300X12	32,93	FMD350300X12	34,63	
3,0	6	2,90	15	5,0	65	FMD220300X15	33,80	FMD440300X15	33,80	FMD350300X15	34,63	
3,0	6	2,90	20	5,0	65	FMD220300X20	33,80	FMD440300X20	33,80	FMD350300X20	34,63	
3,0	6	2,90	25	5,0	65	FMD220300X25	33,80	FMD440300X25	33,80	FMD350300X25	35,36	
3,0	6	2,90	30	5,0	80	FMD220300X30	41,08	FMD440300X30	41,08	FMD350300X30	42,90	
3,0	6	2,90	35	5,0	80	FMD220300X35	41,08	FMD440300X35	41,08	FMD350300X35	42,90	
3,0	6	2,90	40	5,0	80	FMD220300X40	41,08	FMD440300X40	41,08	FMD350300X40	42,90	
3,0	6	2,90	50	5,0	100	FMD220300X50	44,20	FMD440300X50	44,20	FMD350300X50	46,77	
4,0	6	3,90	10	6,0	57	FMD220400X10	32,07	FMD440400X10	32,07	FMD350400X10	33,80	
4,0	6	3,90	12	6,0	60	FMD220400X12	32,93	FMD440400X12	32,93	FMD350400X12	34,63	
4,0	6	3,90	16	6,0	65	FMD220400X16	33,80	FMD440400X16	33,80	FMD350400X16	34,63	
4,0	6	3,90	20	6,0	65	FMD220400X20	33,80	FMD440400X20	33,80	FMD350400X20	34,63	
4,0	6	3,90	25	6,0	65	FMD220400X25	33,80	FMD440400X25	33,80	FMD350400X25	35,36	
4,0	6	3,90	30	6,0	80	FMD220400X30	41,08	FMD440400X30	41,08	FMD350400X30	42,90	
4,0	6	3,90	35	6,0	80	FMD220400X35	41,08	FMD440400X35	41,08	FMD350400X35	42,90	
4,0	6	3,90	40	6,0	80	FMD220400X40	41,08	FMD440400X40	41,08	FMD350400X40	42,90	
4,0	6	3,90	50	6,0	100	FMD220400X50	44,20	FMD440400X50	44,20	FMD350400X50	46,77	
5,0	6	4,80	12	7,0	60	FMD220500X12	32,93	FMD440500X12	32,93	FMD350500X12	-	
5,0	6	4,80	20	7,0	65	FMD220500X20	33,80	FMD440500X20	33,80	FMD350500X20	34,63	
5,0	6	4,80	30	7,0	80	FMD220500X30	41,08	FMD440500X30	41,08	FMD350500X30	42,90	
5,0	6	4,80	40	7,0	80	FMD220500X40	41,08	FMD440500X40	41,08	FMD350500X40	42,90	
5,0	6	4,80	50	7,0	100	FMD220500X50	44,20	FMD440500X50	44,20	FMD350500X50	46,77	



2Z 4Z

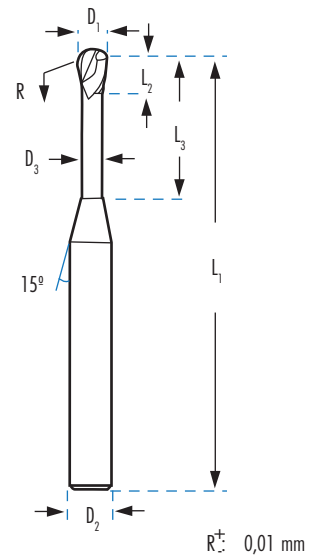

## FRAISES CARBURE ÉBAUCHE PROFIL MOYEN

USAGE  
GÉNÉRAL

CARBURE



45°

CYLINDRIQUE

TiAlN

56  
HRc

## SÉRIE COURTE

FMD3					
D1 mm	D2 mm	L1 mm	L2 mm	Z	€
TOL D1 +0 -0,05	TOL D2 h6				
6	6	50	16	4	35,85
8	8	60	19	4	48,58
10	10	75	22	4	74,76
12	12	75	26	4	102,61
16	16	92	32	4	233,43
20	20	100	38	4	349,80



## SÉRIE LONGUE

FMD43					
D1 mm	D2 mm	L1 mm	L2 mm	Z	€
TOL D1 +0 -0,05	TOL D2 h6				
6	6	80	25	4	51,95
8	8	90	35	4	72,59
10	10	100	45	4	110,55
12	12	100	50	4	146,00
16	16	150	65	4	337,03
20	20	150	70	4	515,70



## FRAISES CARBURE ÉBAUCHE, PROFIL FIN ET GROS

USAGE  
GÉNÉRAL

CARBURE



30°

CYLINDRIQUE

USAGE  
GÉNÉRAL

CARBURE



30°

CYLINDRIQUE

56  
HRc

FMD1					
D1 mm	D2 mm	L1 mm	L2 mm	Z	€
TOL D1 +0 -0,05	TOL D2 h6				
6	6	63	19	3	29,03 *
8	8	63	19	3	31,16 *
12	12	75	25	4	50,31 *
16	16	88	32	4	86,09 *
20	20	100	38	4	100,77 *

\*Jusqu'à fin de stock



FMD6					
D1 mm	D2 mm	L1 mm	L2 mm	Z	€
TOL D1 +0 -0,05	TOL D2 h6				
6	6	63	19	3	29,03 *
8	8	63	19	3	31,16 *
12	12	75	25	4	50,31 *
16	16	88	32	4	86,09 *
20	20	100	38	4	100,77 *

\*Jusqu'à fin de stock



**FRAISES 2 DENTS, SÉRIE COURTE, HÉLICE 30°**

Réf. FMG10

**INOX**

Ti



**CARBURE**



**CYLINDRIQUE**

**TiAlN**

**2 Z**



**Micro Grain  
CARBURE**

Fraises

Rose

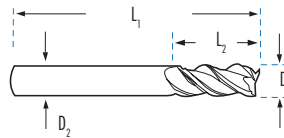

**SÉRIE COURTE**

R.P.M. ET AVANCE						FMG10					
R.P.M. rev./min	AVANCE mm/min	R.P.M. rev./min	AVANCE mm/min	INOX		D1 mm	D2 mm	L1 mm	L2 mm	€	
				<30 HRc	30-45 HRc						
21.500	170	12.900	101	10.750	84	1,0	6	40	2,5	25,99*	
15.000	180	9.000	107	7.500	89	1,5	6	40	4,0	25,99*	
11.560	190	7.560	120	6.300	90	2,0	6	50	6,0	38,62	
8.920	210	5.560	140	4.620	120	3,0	6	50	8,0	38,62	
7.560	300	4.620	180	3.880	150	4,0	6	50	11,0	38,62	
6.300	320	3.780	190	3.160	160	5,0	6	50	12,0	38,62	
5.560	350	3.360	220	2.840	180	6,0	6	50	12,0	38,62	
4.880	385	2.940	220	2.470	180	7,0	8	60	16,0	35,78*	
4.200	380	2.520	200	2.100	180	8,0	8	60	15,0	53,15	
3.730	375	2.260	190	1.890	180	9,0	10	70	19,0	49,27*	
3.260	330	2.000	160	1.680	160	10,0	10	72	20,0	73,20	
2.740	280	1.680	130	1.360	130	12,0	12	75	24,0	103,39	
2.470	265	1.520	125	1.210	125	14,0	14	85	26,0	119,86*	
2.200	220	1.360	110	1.060	110	16,0	16	92	30,0	194,05	
1.680	170	1.060	80	840	80	20,0	20	105	38,0	155,40*	
1.360	130	840	70	680	60	25,0	25	120	45,0	202,30*	



\*Jusqu'à fin de stock

**FRAISES 3 DENTS, SÉRIE COURTE, HÉLICE VARIABLE**

Réf. FMD67

**INOX**

Ti



**CARBURE**



**CYLINDRIQUE**

**TiAlSiN**

**3 Z**



**Micro Grain  
CARBURE**

**SÉRIE COURTE**

FMD67					
	TOL e8	TOL h6	L1 mm	L2 mm	€
	D1 mm	D2 mm			
FMD670300	3	6	50	8	32,66
FMD670400	4	6	50	11	32,66
FMD670500	5	6	50	13	32,66
FMD670600	6	6	50	16	32,66
FMD670800	8	8	60	19	41,18
FMD671000	10	10	73	22	60,84
FMD671200	12	12	75	26	82,99
FMD671400	14	14	85	30	148,11
FMD671600	16	16	92	32	161,62
FMD672000	20	20	100	38	238,37



Fraise 3 lèvres, coupe au centre, hélice variable avec revêtement TiAlSiN.

L'angle d'hélice variable minimise les vibrations et, associé au revêtement TiAlSiN, permet d'offrir des performances d'usinage spectaculaires.

**FRAISES 4 DENTS, SÉRIE COURTE, HÉLICE VARIABLE**

Fraises

Rose

Réf. FMG12

INOX

INOX  
AISI 316L

Ti

INC

55  
HRc

CARBURE



TiAlSiN

4 Z

Micro Grain  
CARBURE

SÉRIE COURTE

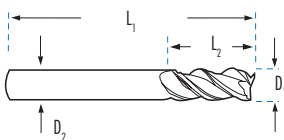

R.P.M. ET AVANCE

R.P.M. ET AVANCE						FMG12					
R.P.M. rev./min	AVANCE mm/min	R.P.M. rev./min	AVANCE mm/min	R.P.M. rev./min	AVANCE mm/min	TOL -0,03 D1 mm	TOL h6 D2 mm	L1 mm	L2 mm	€	
											<30 HRc
11.560	280	7.560	170	6.300	140	FMG120200	2,0	6	40	*6	21,98*
10.240	300	6.560	185	5.460	155	FMG120250	2,5	6	40	*8	21,98*
8.920	320	5.560	200	4.620	170	FMG120300	3,0	6	50	8	32,66
7.560	570	4.620	350	3.880	280	FMG120400	4,0	6	50	11	32,66
6.300	600	3.780	360	3.160	300	FMG120500	5,0	6	50	13	32,66
5.560	660	3.360	410	2.840	330	FMG120600	6,0	6	50	16	32,66
4.200	710	2.520	380	2.100	350	FMG120800	8,0	8	60	19	41,18
3.730	660	2.260	340	1.890	325	FMG120900	9,0	10	70	*19	40,95*
3.260	610	2.000	300	1.680	300	FMG121000	10,0	10	73	22	60,84
2.740	520	1.680	250	1.360	240	FMG121200	12,0	12	75	26	82,99
2.470	465	1.520	225	1.210	220	FMG121400	14,0	14	85	30	113,36
2.200	410	1.360	200	1.060	200	FMG121600	16,0	16	92	32	161,62
1.940	365	1.210	180	950	175	FMG121800	18,0	18	92	38	238,37
1.680	320	1.060	160	840	150	FMG122000	20,0	20	100	38	238,37



\*Jusqu'à fin de stock

Fraise pour matériaux de haute dureté. Fraise 4 lèvres, coupe au centre, hélice variable avec revêtement TiAlSiN.

L'angle d'hélice variable minimise les vibrations et, associé au revêtement TiAlSiN, permet d'offrir des performances d'usinage spectaculaires.

**FRAISES 4 DENTS HÉLICE VARIABLE**

Réf. FMG83

INOX

INOX  
AISI 316L

Ti

INC

CARBURE



TiAlSiN

4 Z

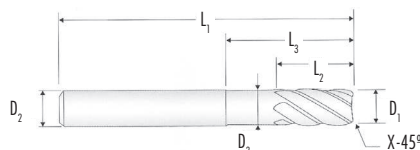
Micro Grain  
CARBURE

R.P.M. ET AVANCE

R.P.M. ET AVANCE				FMG83							
R.P.M. rev./min	AVANCE mm/min	R.P.M. rev./min	AVANCE mm/min	TOL -0,03 D1 mm	TOL h6 D2 mm	L1 mm	L2 mm	L3 mm	X-45°	€	
											INOX AISI 316L
10.185	195	14.260	205	FMG830300	3,0	6	57	8	11	0,07	55,21
7.600	250	14.260	255	FMG830400	4,0	6	57	11	14	0,09	55,21
6.110	310	8.655	310	FMG830500	5,0	6	57	13	16	0,12	55,21
5.095	360	7.130	360	FMG830600	6,0	6	57	13	21	0,20	55,21
3.820	435	5.345	465	FMG830800	8,0	8	63	19	27	0,25	70,73
3.055	590	4.275	585	FMG831000	10,0	10	73	22	32	0,35	103,25
2.545	565	3.565	565	FMG831200	12,0	12	83	26	38	0,40	139,16
2.180	520	3.055	520	FMG831400	14,0	14	84	30	40	0,40	199,71
1.910	480	2.670	480	FMG831600	16,0	16	92	32	44	0,40	234,54
1.525	470	2.140	470	FMG832000	20,0	20	104	38	55	0,40	370,81



Fraise pour matériaux à haute teneur en nickel. Fraise 4 lèvres, coupe au centre avec chanfrein de 45°, hélice variable avec revêtement TiAlSiN. Son angle d'hélice variable minimise les vibrations et, associé au revêtement TiAlSiN, permet d'offrir des performances d'usinage spectaculaires.

**FRAISE MULTIUSAGES**

**NEW**

Réf. FMG80

**TOP  
MULTI-  
MATIÈRES**



**CARBURE**



**TiAlN**

**4 Z**



**Micro Grain  
CARBURE**

**SÉRIE COURTE**

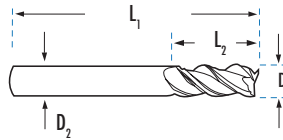

							FMG80
	TOL e8	TOL h6					
	D1 mm	D2 mm	D3 mm	L1 mm	L2 mm	L3 mm	€
FMG800300	3	6	8	20	0,05	57	36,66
FMG800400	4	6	11	20	0,05	57	36,66
FMG800500	5	6	13	21	0,07	57	36,66
FMG800600	6	6	13	21	0,10	57	36,66
FMG800800	8	8	19	27	0,15	63	44,81
FMG801000	10	10	22	32	0,15	73	65,00
FMG801200	12	12	26	38	0,25	83	92,25
FMG801400	14	14	30	40	0,30	84	117,26
FMG801600	16	16	32	44	0,35	92	164,49
FMG801800	20	20	38	55	0,35	104	242,32



Fraise 4 lèvres, coupe au centre, hélice variable avec revêtement TiAlN.

Son angle d'hélice variable minimise les vibrations et, associé au revêtement TiAlN, offre des performances d'usinage spectaculaires.

**FRAISE HÉMISPÉRIQUE POUR MOULISTES**

**NEW**

Réf. FMG86

**MOULISTES**

**INOX**

**Ti**



**CARBURE**



**TiAlSiN**

**4 Z**



**Micro Grain  
CARBURE**

**SÉRIE COURTE**

					FMG86
	TOL e8	TOL h6			
	D1 mm	D2 mm	L1 mm	L2 mm	€
FMG860600	6	6	8	50	33,28
FMG860600X80	6	6	8	80	43,65
FMG860600X100	6	6	8	100	48,07
FMG860600X150	6	6	8	150	63,34
FMG860800	8	8	10	60	42,61
FMG860800X100	8	8	10	100	60,39
FMG860800X150	8	8	10	150	81,52
FMG861000	10	10	13	72	62,99
FMG861000X100	10	10	13	100	86,79
FMG861000X150	10	10	13	150	115,72
FMG861000X200	10	10	13	200	162,52
FMG861200	12	12	15	75	86,27
FMG861200X100	12	12	15	100	121,56
FMG861200X150	12	12	15	150	169,26
FMG861200X200	12	12	15	200	198,41



**FRAISES 6 DENTS, HÉLICE 45°**
**INOX**

**65  
HRc**
**Ti**
**CARBURE**

**45°**
**TiAlN**
**6 Z**

 Matières très dures  
 aciers trempés

**Micro Grain  
CARBURE**

Réf. FMG14

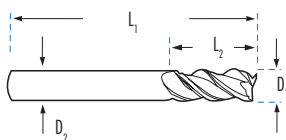
**SÉRIE COURTE**
**R.P.M. ET AVANCE**

R.P.M. rev./min	AVANCE mm/min	R.P.M. rev./min	AVANCE mm/min	INOX		INC	
				R.P.M. rev./min	AVANCE mm/min	R.P.M. rev./min	AVANCE mm/min
8.900	2.670	5.760	1.555	4.850	1.310	2.100	370
7.560	2.260	4.800	1.440	4.100	1.230	1.800	325
6.300	2.090	4.050	1.215	3.700	1.180	1.580	300
5.560	2.000	3.880	1.370	3.370	1.100	1.350	280
4.200	2.000	2.940	1.370	2.490	1.100	1.000	280
3.360	2.000	2.320	1.370	1.920	1.100	440	280
2.840	1.680	2.000	1.160	1.610	1.000	400	250
2.470	1.470	1.740	1.020	1.380	885	355	220
2.100	1.260	1.480	880	1.160	770	310	190
1.890	1.130	1.320	785	1.030	695	280	170
1.680	1.010	1.160	690	900	920	250	155
1.500	900	1.100	600	850	540	220	135

**FMG14**

	TOL -0,03	TOL h6	D1 mm	D2 mm	L1 mm	L2 mm	€
FMG140300	3,0	3	38	8	24,53		
FMG140400	4,0	4	50	11	27,14		
FMG140500	5,0	5	50	13	34,32		
FMG140600	6,0	6	50	16	35,21		
FMG140800	8,0	8	60	19	49,25		
FMG141000	10,0	10	75	22	68,69		
FMG141200	12,0	12	75	26	100,58		
FMG141400	14,0	14	90	32	129,82		
FMG141600	16,0	16	100	32	177,13		
FMG141800	18,0	18	100	38	205,60		
FMG142000	20,0	20	100	38	256,50		
FMG142500	25,0	25	100	38	437,21		

**SÉRIE LONGUE**
**R.P.M. ET AVANCE**

R.P.M. rev./min	AVANCE mm/min	R.P.M. rev./min	AVANCE mm/min	INOX		INC	
				R.P.M. rev./min	AVANCE mm/min	R.P.M. rev./min	AVANCE mm/min
8.900	2.670	5.760	1.555	4.850	1.310	2.100	370
7.560	2.260	4.800	1.440	4.100	1.230	1.800	325
6.300	2.090	4.050	1.215	3.700	1.180	1.580	300
5.560	2.000	3.880	1.370	3.370	1.100	1.350	280
4.200	2.000	2.940	1.370	2.490	1.100	1.000	280
3.360	2.000	2.320	1.370	1.920	1.100	440	280
2.840	1.680	2.000	1.160	1.610	1.000	400	250
2.840	1.680	2.000	1.160	1.610	1.000	400	250
2.470	1.470	1.740	1.020	1.380	885	355	220
2.100	1.260	1.480	880	1.160	770	310	190
2.100	1.260	1.480	880	1.160	770	310	190
1.680	1.010	1.160	690	900	920	250	155
1.680	1.010	1.160	690	900	920	250	155
1.680	1.010	1.160	690	900	920	250	155
1.500	900	1.100	600	850	540	220	135
1.500	900	1.100	600	850	540	220	135
1.500	900	1.100	600	850	540	220	135

**FMG25**

	TOL -0,03	TOL h6	D1 mm	D2 mm	L1 mm	L2 mm	€
FMG250300	3,0	3	60	15	24,18		
FMG250400	4,0	4	80	20	27,25		
FMG250500	5,0	5	80	25	31,29		
FMG250600	6,0	6	80	25	37,94		
FMG250800	8,0	8	90	35	55,41		
FMG251000	10,0	10	100	45	75,00		
FMG251200	12,0	12	100	50	107,15		
FMG251200X125	12,0	12	125	70	132,67		
FMG251400	14,0	14	150	65	145,65		
FMG251600	16,0	16	150	65	187,15		
FMG251600X165	16,0	16	165	100	213,60		
FMG252000	20,0	20	150	70	276,78		
FMG252000X165	20,0	20	165	100	319,26		
FMG252000X200	20,0	20	200	135	408,06		
FMG252500	25,0	25	150	75	532,10		
FMG252500X165	25,0	25	165	100	616,06		
FMG252500X200	25,0	25	200	140	690,82		
FMG253200	32,0	32	165	100	863,55		
FMG253200X210	32,0	32	210	150	1.036,13		



## FRAISES POUR ALUMINIUM, 2 ET 3 DENTS, HÉLICE 45°

Al

Cu

PVC



45°  
N



CYLINDRIQUE

2 Z



Réf. FMD59

3 Z



Réf. FMD33

Micro Grain  
CARBURE

### SÉRIE COURTE

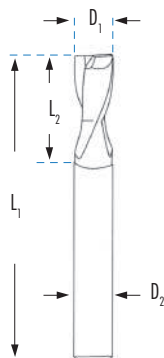

### R.P.M. ET AVANCE

R.P.M. ET AVANCE		
Al		
R.P.M. rev./min.	AVANCE 1 mm/min	AVANCE 2 mm/min
10.000	700	900
10.000	900	1.100
10.000	1.000	1.300
10.000	1.200	1.500
8.000	1.400	1.800
8.000	1.700	2.100
8.000	2.100	2.600
6.000	1.800	2.200
6.000	1.900	2.400
4.000	1.600	1.900

TOL -0,05		TOL h6						FMD59		FMD33	
D1 mm	D2 mm	L1 mm	L2 mm			2 Z		3 Z		€	€
3,0	6,0	50	8	FMD590300		<b>27,60</b>	FMD330300	<b>27,60</b>			
4,0	6,0	50	11	FMD590400		<b>29,90</b>	FMD330400	<b>29,90</b>			
5,0	6,0	50	13	FMD590500		<b>30,89</b>	FMD330500	<b>30,89</b>			
6,0	6,0	50	16	FMD590600		<b>35,07</b>	FMD330600	<b>35,07</b>			
8,0	8,0	60	19	FMD590800		<b>49,97</b>	FMD330800	<b>49,97</b>			
10,0	10,0	72	25	FMD591000		<b>73,47</b>	FMD331000	<b>73,47</b>			
12,0	12,0	75	30	FMD591200		<b>97,07</b>	FMD331200	<b>97,07</b>			
14,0	14,0	84	35	FMD591400		<b>136,23</b>	FMD331400	<b>136,23</b>			
16,0	16,0	92	40	FMD591600		<b>172,80</b>	FMD331600	<b>172,80</b>			
20,0	20,0	100	45	FMD592000		<b>284,99</b>	FMD332000	<b>284,99</b>			

### TOLÉRANCES SELON DIN 7160 ET 7161

Gamme de tolérances $\mu\text{m}$ / Diamètre nominal en mm					
	de 1 à 3	de 3 à 6	de 6 à 10	de 10 à 18	de 18 à 30
TOL	0	0	0	0	0
h10	- 40	- 48	- 58	- 70	- 84
TOL	0	0	0	0	0
h6	- 6	- 8	- 9	- 11	- 13

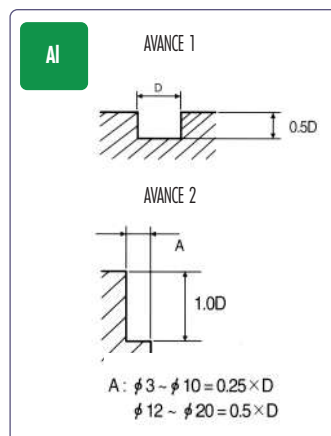



## FRAISES POUR ALUMINIUM, 2 ET 3 DENTS, HÉLICE 45°, SÉRIE LONGUE

NEW

Al

Cu

PVC



CYLINDRIQUE

2 Z



Réf. FMD69

3 Z



Réf. FMD23

Micro Grain  
CARBURE

SÉRIE LONGUE

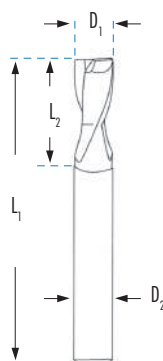

## R.P.M. ET AVANCE

Al

R.P.M. ET AVANCE							FMD69		FMD23	
			TOL -0,05	TOL h6				2 Z		3 Z
R.P.M. rev./min.	AVANCE 1 mm/min	AVANCE 2 mm/min	D1 mm	D2 mm	L1 mm	L2 mm		€		€
10.000	1.200	1.500	6,0	6,0	80	25	FMD690600	40,33	FMD230600	40,33
8.000	1.400	1.800	8,0	8,0	90	35	FMD690800	57,47	FMD230800	57,47
8.000	1.700	2.100	10,0	10,0	100	45	FMD691000	84,49	FMD231000	84,49
8.000	2.100	2.600	12,0	12,0	100	50	FMD691200	111,63	FMD231200	111,63
6.000	1.800	2.200	14,0	14,0	165	65	FMD691400	156,66	FMD231400	156,66
6.000	1.900	2.400	16,0	16,0	150	65	FMD691600	198,72	FMD231600	198,72
4.000	1.600	1.900	20,0	20,0	150	70	FMD692000	327,74	FMD232000	327,74

## TOLÉRANCES SELON DIN 7160 ET 7161

Gamme de tolérances  $\mu\text{m}$  / Diamètre nominal en mm

	de 1 à 3	de 3 à 6	de 6 à 10	de 10 à 18	de 18 à 30
TOL	0	0	0	0	0
h10	- 40	- 48	- 58	- 70	- 84
TOL	0	0	0	0	0
h6	- 6	- 8	- 9	- 11	- 13

Al

AVANCE 1

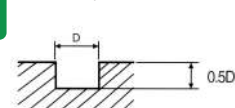

AVANCE 2

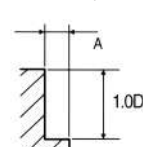
A:  $\phi 3 - \phi 10 = 0.25 \times D$   
 $\phi 12 - \phi 20 = 0.5 \times D$



## FRAISES POUR ALUMINIUM, 2 DENTS, HÉMISPÉRIQUES, HÉLICE 45°



Réf. FMD93  
Réf. FMD94

Micro Grain  
CARBURE

### SÉRIE COURTE

R.P.M. ET AVANCE									FMD93
AI			TOL -0,05	TOL h6					2Z
R.P.M rev./min.	AVANCE 1 mm/min	AVANCE 2 mm/min	D1 mm	D2 mm	L1 mm	L2 mm		€	
10.000	700	900	3,0	6,0	50	6	FMD930300	25,20	
10.000	900	1.100	4,0	6,0	50	8	FMD930400	28,72	
10.000	1.000	1.300	5,0	6,0	50	10	FMD930500	30,38	
10.000	1.200	1.500	6,0	6,0	50	12	FMD930600	35,75	
8.000	1.400	1.800	8,0	8,0	60	15	FMD930800	44,13	
8.000	1.700	2.100	10,0	10,0	72	20	FMD931000	66,32	
8.000	2.100	2.600	12,0	12,0	75	24	FMD931200	82,39	
6.000	1.800	2.200	14,0	14,0	83	26	FMD931400	121,97	
6.000	1.900	2.400	16,0	16,0	92	30	FMD931600	154,32	
4.000	1.600	1.900	20,0	20,0	100	40	FMD932000	237,86	

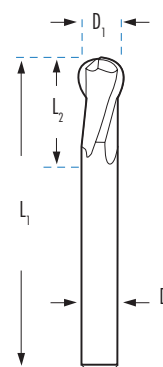

### SÉRIE LONGUE

R.P.M. ET AVANCE									FMD94	
AI			TOL -0,05	TOL h6					2Z	
R.P.M rev./min.	AVANCE 1 mm/min	AVANCE 2 mm/min	D1 mm	D2 mm	D3 mm	L3 mm	L1 mm	L2 mm		€
10.000	1.200	1.500	6,0	6,0	5,5	35	80	12	FMD940600	42,33
8.000	1.400	1.800	8,0	8,0	7,5	35	90	15	FMD940800	47,06
8.000	1.700	2.100	10,0	10,0	9,5	45	100	20	FMD941000	75,00
8.000	2.100	2.600	12,0	12,0	11,5	50	100	24	FMD941200	94,47
6.000	1.900	2.400	16,0	16,0	15,5	92	150	30	FMD941600	185,21
4.000	1.600	1.900	20,0	20,0	19,5	92	150	40	FMD942000	270,23

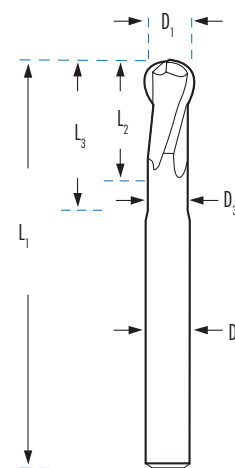

**FRAISES 3 À 4 DENTS, SÉRIE COURTE, HÉLICE 50°**

Réf. FMG13

**INOX**
45  
HRC

Ti

**INC**
**CARBURE**

50°



WELDON

**TiAlN**
**3-4 Z**

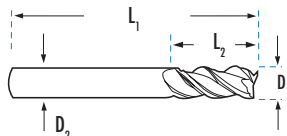
**Micro Grain  
CARBURE**
**SÉRIE COURTE**

**R.P.M. ET AVANCE**

R.P.M. rev./min	AVANCE mm/min	R.P.M. ET AVANCE		R.P.M. rev./min	AVANCE mm/min	R.P.M. rev./min	AVANCE mm/min
		<30 HRc	30-45 HRc				
4.200	310	2.520	180	2.100	160	920	40
3.260	310	2.000	140	1.680	140	740	40
2.740	250	1.680	120	1.370	120	620	30
2.200	200	1.360	100	1.050	100	460	25
1.940	175	1.210	85	950	85	410	20
1.680	150	1.060	70	840	70	350	20
1.360	115	840	60	670	60	300	15

**FMG13**

	TOL -0,03	TOL h6	L1 mm	L2 mm	Z	€
	D1 mm	D2 mm				
FMG130800	8,0	8	60	19	3	30,99*
FMG131000	10,0	10	70	22	3	45,78*
FMG131200	12,0	12	75	25	3	62,74*
FMG131600	16,0	16	90	32	3	103,96*
FMG131800	18,0	18	90	32	3	121,54*
FMG132000	20,0	20	100	28	4	137,83*
FMG132500	25,0	25	120	45	4	220,44*

\*Jusqu'à fin de stock

**NOTE:** Lors de rainurage d'un côté, il conviendra d'augmenter l'avance de 30% et maintenir les R.P.M.

**TOLÉRANCES SELON DIN 7160 ET 7161**

 Gamme de tolérances  $\mu\text{m}$  / Diamètre nominal en mm

	de 1 à 3	de 3 à 6	de 6 à 10	de 10 à 18	de 18 à 30
<b>TOL e8</b>	- 14	- 20	- 25	- 32	- 40
	- 28	- 38	- 47	- 59	- 73
<b>TOL h6</b>	0	0	0	0	0
	- 6	- 8	- 9	- 11	- 13

**FRAISES 3 À 5 DENTS, ÉBAUCHE PROFIL FIN**



Réf. FMG15  
Réf. FMG16



Ti

INC

CARBURE



TiAIN



Micro Grain  
CARBURE

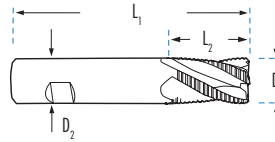

**SÉRIE COURTE**

**R.P.M. ET AVANCE**

				INOX		INC	
R.P.M. rev./min	AVANCE mm/min	R.P.M. rev./min	AVANCE mm/min	R.P.M. rev./min	AVANCE mm/min	R.P.M. rev./min	AVANCE mm/min
15.600	2.320	12.400	840	8.400	570	2.400	190
13.600	2.320	10.800	840	7.350	570	2.100	190
11.600	2.320	9.200	840	6.300	570	1.800	190
10.400	2.320	8.400	840	5.700	570	1.550	190
9.200	2.320	7.600	840	5.100	570	1.300	190
8.000	2.400	6.000	800	4.200	570	1.200	190
6.800	2.400	5.200	840	3.600	570	900	130
6.000	2.400	4.800	760	3.300	510	800	110
4.800	2.160	3.600	560	2.400	360	660	100
4.300	2.150	3.200	620	2.160	410	600	100

**FMG15**

	TOL h10	TOL h6	L1 mm	L2 mm	Z	€
	D1 mm	D2 mm				
FMG150600	6,0	6	54	7	3	23,07*
FMG150700	7,0	8	58	8	3	26,96*
FMG150800	8,0	8	58	9	3	26,96*
FMG150900	9,0	10	66	13	4	40,20*
FMG151000	10,0	10	66	14	4	40,20*
FMG151200	12,0	12	73	16	4	51,57*
FMG151400	14,0	14	75	18	4	62,55*
FMG151600	16,0	16	82	22	4	83,93*
FMG152000	20,0	20	92	26	4	121,49*
FMG152500	25,0	25	110	25	5	189,26*

\*Jusqu'à fin de stock



**SÉRIE LONGUE**

**R.P.M. ET AVANCE**

				INOX		INC	
R.P.M. rev./min	AVANCE mm/min	R.P.M. rev./min	AVANCE mm/min	R.P.M. rev./min	AVANCE mm/min	R.P.M. rev./min	AVANCE mm/min
13.600	2.320	10.800	840	7.350	570	2.100	190
11.600	2.320	9.200	840	6.300	570	1.800	190
9.200	2.320	7.600	840	5.100	570	1.300	190
6.800	2.400	5.200	840	3.600	570	900	130
6.000	2.400	4.800	760	3.300	510	800	110
4.800	2.160	3.600	560	2.400	360	660	100
4.300	2.150	3.200	620	2.160	410	600	100

**FMG16**

	TOL h10	TOL h6	L1 mm	L2 mm	Z	€
	D1 mm	D2 mm				
FMG160700	7,0	8	63	16	3	28,97*
FMG160800	8,0	8	63	16	3	28,97*
FMG161000	10,0	10	72	22	4	43,21*
FMG161400	14,0	14	83	26	4	67,24*
FMG161600	16,0	16	92	32	4	90,23*
FMG162000	20,0	20	104	38	4	130,63*
FMG162500	25,0	25	121	45	5	203,50*

\*Jusqu'à fin de stock



**TOLÉRANCES SELON DIN 7160 ET 7161**

Gamme de tolérances $\mu\text{m}$ / Diamètre nominal en mm					
	de 1 à 3	de 3 à 6	de 6 à 10	de 10 à 18	de 18 à 30
TOL e8	0	0	0	0	0
	- 40	- 48	- 58	- 70	- 84
TOL h6	0	0	0	0	0
	- 6	- 8	- 9	- 11	- 13

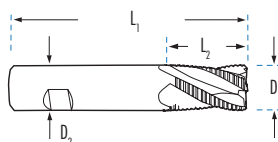
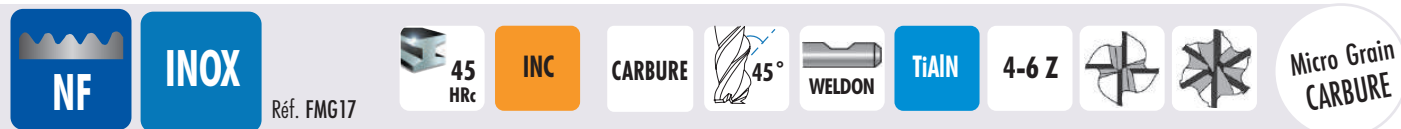
**FRAISES 4 À 6 DENTS, SÉRIE COURTE, HÉLICE 45°, ÉBAUCHE PROFIL FIN**

**SÉRIE COURTE**

R.P.M. ET AVANCE								FMG17						
<30 HRc		30-45 HRc		INOX		INC		TOL h10	TOL h6	L1	L2	Z	€	
R.P.M. rev./min	AVANCE mm/min	R.P.M. rev./min	AVANCE mm/min	R.P.M. rev./min	AVANCE mm/min	R.P.M. rev./min	AVANCE mm/min	D1 mm	D2 mm	L1 mm	L2 mm	Z	€	
11.600	2.320	9.200	840	6.300	570	1.800	190	FMG170800	8,0	8	58	9	4	26,96*
8.000	2.400	6.000	800	4.200	570	1.200	190	FMG171200	12,0	12	73	16	4	51,57*
6.000	2.400	4.800	760	3.300	510	800	110	FMG171600	16,0	16	82	22	5	83,93*
4.800	2.160	3.600	560	2.400	360	660	100	FMG172000	20,0	20	92	26	6	107,99*

\*Jusqu'à fin de stock

**FRAISES DE 3 À 6 DENTS, SÉRIE LONGUE, HÉLICE 45°, ÉBAUCHE PROFIL FIN**

**SÉRIE LONGUE**

R.P.M. ET AVANCE								FMG18						
<30 HRc		30-45 HRc		INOX		INC		TOL h10	TOL h6	L1	L2	Z	€	
R.P.M. rev./min	AVANCE mm/min	R.P.M. rev./min	AVANCE mm/min	R.P.M. rev./min	AVANCE mm/min	R.P.M. rev./min	AVANCE mm/min	D1 mm	D2 mm	L1 mm	L2 mm	Z	€	
20.100	4.600	18.400	1.700	12.600	1.040	3.800	399	FMG180400	4,0	6	57	11	3	24,07*
15.600	2.320	12.400	840	8.400	570	2.400	190	FMG180600	6,0	6	57	16	4	24,07*
13.600	2.320	10.800	840	7.350	570	2.100	190	FMG180700	7,0	8	63	16	4	28,13*
11.600	2.320	9.200	840	6.300	570	1.800	190	FMG180800	8,0	8	63	16	4	28,13*
9.200	2.320	7.600	840	5.100	570	1.300	190	FMG181000	10,0	10	72	22	4	41,95*
6.800	2.400	5.200	840	3.600	570	900	130	FMG181400	14,0	14	83	26	5	65,28*
6.000	2.400	4.800	760	3.300	510	800	110	FMG181600	16,0	16	92	32	5	87,61*
4.800	2.160	3.600	560	2.400	360	660	100	FMG182000	20,0	20	104	38	6	140,91*
4.300	2.150	3.200	620	2.160	410	600	100	FMG182500	25,0	25	121	45	6	246,97*

\*Jusqu'à fin de stock



**FRAISES DE 4 À 6 DENTS, SÉRIE LONGUE, HÉLICE 45°, ÉBAUCHE PROFIL FIN**



Ref. FMG19



CARBURE



TiAIN

4-6 Z



Micro Grain  
CARBURE

**SÉRIE LONGUE**

FMG19								
	TOL h10	TOL h6						
	D1 mm	D2 mm	D3 mm	L1 mm	L2 mm	L3 mm	Z	€
FMG190600	6,0	6	5,5	57	16	20	4	29,72*
FMG190800	8,0	8	7,5	63	16	26	4	34,74*
FMG191000	10,0	10	9,5	72	22	31	4	51,82*
FMG191200	12,0	12	11,5	83	26	37	4	66,49*
FMG191600	16,0	16	15,5	100	32	51	5	86,66*
FMG192000	20,0	20	19,2	110	38	59	6	139,31*

\*Jusqu'à fin de stock

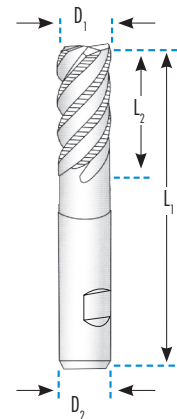

**R.P.M. ET AVANCE**

R.P.M. rev./min	<30 HRc	R.P.M. rev./min	30-45 HRc	R.P.M. rev./min	INOX	R.P.M. rev./min	INC
	AVANCE mm/min		AVANCE mm/min		AVANCE mm/min		AVANCE mm/min
15.600	2.320	12.400	840	8.400	570	2.400	190
11.600	2.320	9.200	840	6.300	570	1.800	190
9.200	2.320	7.600	840	5.100	570	1.300	190
8.000	2.400	6.000	800	4.200	570	1.200	190
6.000	2.400	4.800	760	3.300	510	800	110
4.800	2.160	3.600	560	2.400	360	660	100

**TOLÉRANCES SELON DIN 7160 ET 7161**

Gamme de tolérances $\mu\text{m}$ / Diamètre nominal en mm					
	de 1 à 3	de 3 à 6	de 6 à 10	de 10 à 18	de 18 à 30
TOL h10	0	0	0	0	0
	- 40	- 48	- 58	- 70	- 84
TOL h6	0	0	0	0	0
	- 6	- 8	- 9	- 11	- 13

## FRAISES 2 LÈVRES POUR ACIERS DE DURETÉ EXTRÊME 70HRc

70  
HRc

Réf. FMG01

CARBURE



30°



CYLINDRIQUE

BLUE

2 Z

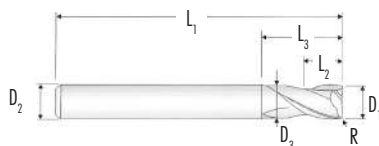
Micro Grain  
CARBURE

## R.P.M. ET AVANCE

50-55 HRc		55-60 HRc		60-65 HRc		65-70 HRc	
R.P.M. rev./min.	AVANCE mm/min	R.P.M. rev./min.	AVANCE mm/min	R.P.M. rev./min.	AVANCE mm/min	R.P.M. rev./min.	AVANCE mm/min
25.500	360	20.500	215	16.000	135	12.500	88
21.500	390	17.500	240	13.500	150	11.000	102
11.500	420	9.500	260	7.500	160	6.400	115
10.150	430	8.350	270	6.550	165	5.575	118
8.800	440	7.200	270	5.600	170	4.750	118
8.550	470	6.800	280	5.350	175	4.600	125
6.900	480	5.300	280	4.200	180	3.700	130
4.100	415	3.200	240	2.550	155	2.200	112
3.500	415	2.650	240	2.100	155	1.860	112
2.600	365	2.000	210	1.600	135	1.400	98
2.050	335	1.600	295	1.300	125	1.100	88

## FMG01

	TOL Spéciale	TOL h6	D3 mm	L1 mm	L2 mm	L3 mm	R	€
	D1 mm	D2 mm						
FMG010100	1,0	3	-	40	1,5	-	0,1	17,54*
FMG010150	1,5	3	-	40	2,2	-	0,1	17,54*
FMG010300	3,0	6	2,9	45	4,0	7	0,1	23,24*
FMG010350	3,5	6	3,3	45	5,0	9	0,1	23,24*
FMG010400	4,0	6	3,8	45	5,0	9	0,1	23,24*
FMG010450	4,5	6	4,3	45	6,0	10	0,1	23,24*
FMG010600	6,0	6	5,8	50	7,0	14	0,2	23,24*
FMG011000	10,0	10	9,7	75	12,0	25	0,2	43,92*
FMG011200	12,0	12	11,7	75	15,0	30	0,3	60,56*
FMG011600	16,0	16	15,7	90	18,0	38	0,3	100,97*
FMG012000	20,0	20	19,7	100	24,0	45	0,3	133,56*

\*Jusqu'à fin de stock



## FRAISES 4 LÈVRES POUR ACIERS DE DURETÉ EXTRÊME 70HRc

70  
HRc

Réf. FMG04

CARBURE



30°



CYLINDRIQUE

BLUE

4 Z

Micro Grain  
CARBURE

## R.P.M. ET AVANCE

50-55 HRc		55-60 HRc		60-65 HRc		65-70 HRc	
R.P.M. rev./min.	AVANCE mm/min	R.P.M. rev./min.	AVANCE mm/min	R.P.M. rev./min.	AVANCE mm/min	R.P.M. rev./min.	AVANCE mm/min
25.500	710	20.500	430	16.000	270	12.500	175
21.500	775	17.500	475	13.500	295	11.000	200
17.500	840	14.500	520	11.000	320	9.500	230
11.500	840	9.500	520	7.500	320	6.400	230
10.150	860	8.350	530	6.550	328	5.575	240
8.800	880	7.200	540	5.600	335	4.750	240
8.550	940	6.800	560	5.350	353	4.600	255
6.900	950	5.300	560	4.200	350	3.700	260
4.100	840	3.200	480	2.550	310	2.200	220
3.500	840	2.650	480	2.100	300	1.860	220
2.600	730	2.000	420	1.600	270	1.400	200
2.050	650	1.600	380	1.300	250	1.100	180

## FMG04

	TOL Spéciale	TOL h6	D3 mm	L1 mm	L2 mm	L3 mm	R	€
	D1 mm	D2 mm						
FMG040100	1,0	3	-	40	1,5	-	0,1	17,54*
FMG040150	1,5	3	-	40	2,2	-	0,1	17,54*
FMG040200	2,0	3	1,9	40	3,0	6	0,1	15,91*
FMG040300	3,0	6	2,9	45	4,0	7	0,1	23,24*
FMG040350	3,5	6	3,3	45	5,0	9	0,1	23,24*
FMG040400	4,0	6	3,8	45	5,0	9	0,1	23,24*
FMG040450	4,5	6	4,3	45	6,0	10	0,1	23,24*
FMG040600	6,0	6	5,8	50	7,0	14	0,2	23,24*
FMG041000	10,0	10	9,7	75	12,0	25	0,2	43,92*
FMG041200	12,0	12	11,7	75	15,0	30	0,3	60,56*
FMG041600	16,0	16	15,7	90	18,0	38	0,3	100,97*
FMG042000	20,0	20	19,7	100	24,0	45	0,3	133,56*

\*Jusqu'à fin de stock



FRAISES 2 LÈVRES HÉMISPÉRIQUES POUR ACIERS DE DURETÉ EXTRÊME 70HRC



Réf. FMG02

CARBURE



BLUE

2 Z



Micro Grain  
CARBURE

Fraises

Rose

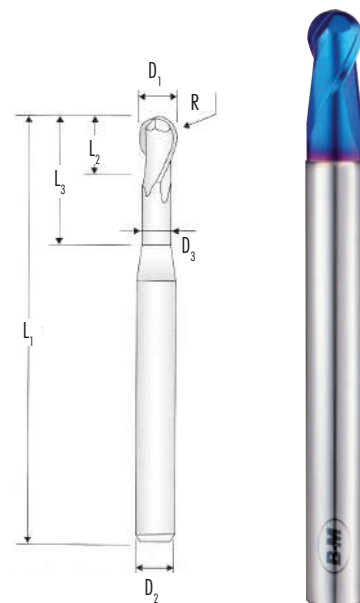

SÉRIE COURTE

R.P.M. ET AVANCE

50-55 HRc		55-60 HRc		60-65 HRc		65-70 HRc	
R.P.M rev./min.	AVANCE mm/min	R.P.M rev./min.	AVANCE mm/min	R.P.M rev./min.	AVANCE mm/ min	R.P.M rev./min.	AVANCE mm/min
57.000	4.000	54.000	3.400	51.000	2.700	48.000	2.300
48.500	4.000	44.500	3.275	41.500	2.750	38.250	2.300
40.000	4.000	35.000	3.150	32.000	2.800	28.500	2.300
26.500	4.000	23.500	3.150	21.000	2.800	19.000	2.300
15.000	3.750	13.500	3.050	11.500	2.550	10.500	2.100
11.000	3.100	10.000	2.500	8.800	2.150	8.000	1.750
9.000	2.700	8.000	2.150	7.000	1.850	6.500	1.550
7.500	2.400	6.600	1.900	5.800	1.650	5.300	1.380
5.600	1.900	5.000	1.550	4.400	1.250	4.000	1.050
5.000	1.800	4.500	1.450	3.950	1.125	3.600	950
4.000	1.600	3.600	1.275	3.150	900	2.875	750
3.600	1.500	3.200	1.200	2.800	800	2.550	660
-	-	-	-	-	-	-	-

FMG02

	TOL Spéciale		TOL h6			TOL R		€
	D1 mm	D2 mm	D3 mm	L1 mm	L2 mm	L3 mm	R	
FMG020100	1,0	4	0,95	50	1,0	2,2	0,5	28,92*
FMG020150	1,5	4	1,40	50	1,5	3,0	0,8	28,92*
FMG020200	2,0	4	1,90	50	2,0	4,0	1,0	27,46*
FMG020300	3,0	6	2,90	60	3,0	6,0	1,5	27,46*
FMG020500	5,0	6	4,90	80	5,0	10,0	2,5	29,55*
FMG020600	6,0	6	5,90	90	6,0	12,0	3,0	31,69*
FMG020800	8,0	8	7,90	100	8,0	16,0	4,0	49,45*
FMG021000	10,0	10	9,90	100	10,0	20,0	5,0	81,55*
FMG021200	12,0	12	11,90	110	12,0	24,0	6,0	104,68*
FMG021400	14,0	14	13,80	110	14,0	28,0	7,0	105,90*
FMG021800	18,0	18	17,80	140	18,0	36,0	9,0	150,96*
FMG022000	20,0	20	19,80	160	20,0	40,0	10,0	213,94*
FMG022500	25,0	25	24,80	180	25,0	50,0	12,5	346,80*

\*Jusqu'à fin de stock

TOLÉRANCES SELON DIN 7160 ET 7161

TOL	Gamme de tolérances $\mu\text{m}$ / Diamètre nominal en mm				
	de 1 à 3	de 3 à 6	de 6 à 10	de 10 à 18	de 18 à 30
Spéciale	0 - 12	0 - 12	0 - 15	0 - 15	0 - 15
h6	0 - 6	0 - 8	0 - 9	0 - 11	0 - 13
R	0 - 5	0 - 10	0 - 10	0 - 10	0 - 10

## FRAISES 6 LÈVRES POUR ACIERS DE DURETÉ EXTRÊME 70HRc



Réf. FMG06

CARBURE



CYLINDRIQUE

BLUE

6 Z

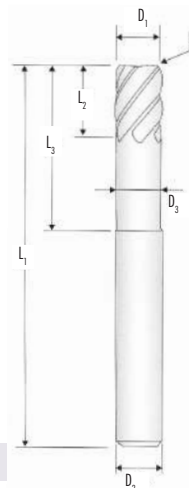
Micro Grain  
CARBURE

## SÉRIE COURTE

## R.P.M. ET AVANCE

50-55 HRc		55-60 HRc		60-65 HRc		65-70 HRc	
R.P.M. rev./min.	AVANCE mm/min	R.P.M. rev./min.	AVANCE mm/min	R.P.M. rev./min.	AVANCE mm/min	R.P.M. rev./min.	AVANCE mm/min
12.000	4.600	10.000	3.100	8.000	2.000	6.000	1.400
9.500	4.100	8.000	2.900	6.400	1.800	4.800	1.300
8.000	3.800	6.600	2.500	5.300	1.600	4.000	1.150

## FMG06

	TOL Spéciale		TOL h6				TOL R	€
	D1 mm	D2 mm	D3 mm	L1 mm	L2 mm	L3 mm	R	
FMG060800	8,0	8	7,65	60	8	24	0,5	39,65*
FMG061000	10,0	10	9,65	70	10	30	1,0	61,85*
FMG061200	12,0	12	11,60	75	12	30	1,0	73,88*

\*Jusqu'à fin de stock

## SÉRIE LONGUE

## R.P.M. ET AVANCE

50-55 HRc		55-60 HRc		60-65 HRc		65-70 HRc	
R.P.M. rev./min.	AVANCE mm/min	R.P.M. rev./min.	AVANCE mm/min	R.P.M. rev./min.	AVANCE mm/min	R.P.M. rev./min.	AVANCE mm/min
16.000	4.900	13.500	3.300	10.500	2.100	8.000	1.450
12.000	4.600	10.000	3.100	8.000	2.000	6.000	1.400
9.500	4.100	8.000	2.900	6.400	1.800	4.800	1.300
8.000	3.800	6.600	2.500	5.300	1.600	4.000	1.150
8.000	3.800	6.600	2.500	5.300	1.600	4.000	1.150
6.000	3.400	5.000	2.300	4.000	1.250	3.000	870
6.000	3.400	5.000	2.300	4.000	1.250	3.000	870
4.800	3.200	4.000	2.100	3.200	1.020	2.400	690
4.800	3.200	4.000	2.100	3.200	1.020	2.400	690
4.800	3.200	4.000	2.100	3.200	1.020	2.400	690

## FMG07

	TOL Spéciale	TOL h6		R	€	
	D1 mm	D2 mm	L1 mm			L2 mm
FMG070600	6,0	6	70	13	0,5	37,77*
FMG070800	8,0	8	90	19	0,5	47,34*
FMG071000	10,0	10	100	22	0,5	71,32*
FMG071200	12,0	12	110	26	0,5	97,28*
FMG071201	12,0	12	110	26	1,0	108,95*
FMG071600	16,0	16	130	32	1,0	131,24*
FMG071601	16,0	16	130	32	1,5	143,33*
FMG072000	20,0	20	140	38	1,0	192,06*
FMG072001	20,0	20	140	38	1,5	209,81*
FMG072002	20,0	20	140	38	2,0	209,81*

\*Jusqu'à fin de stock

## TOLÉRANCES SELON DIN 7160 ET 7161

Gamme de tolérances $\mu\text{m}$ / Diamètre nominal en mm					
	de 1 à 3	de 3 à 6	de 6 à 10	de 10 à 18	de 18 à 30
TOL Spéciale	0	0	0	0	0
	- 12	- 12	- 15	- 15	- 15
TOL h6	0	0	0	0	0
	- 6	- 8	- 9	- 11	- 13



FRAISES POUR ACIERS DE DURETÉ EXTRÊME 70HRC,  
TECHNOLOGIE DE MICROFRAISAGE PIÈCES DE PRÉCISION



70  
HRc

Réf. FMG09

CARBURE



CYLINDRIQUE

BLUE

2 Z



TOL D1  
-0,012

TOL D2  
h6

Micro Grain  
CARBURE

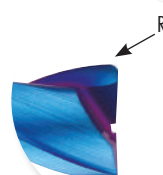
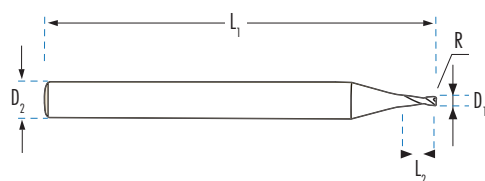

FMG09						
	D1 mm	D2 mm	L1 mm	L2 mm	R	€
FMG090040	0,40	6	50	0,60	-	63,50*
FMG090050	0,50	6	50	0,70	0,05	55,24*
FMG090060	0,60	6	50	0,90	0,05	53,14*
FMG090080	0,80	6	50	1,20	0,05	48,97*
FMG090100	1,00	6	50	1,50	0,10	46,93*
FMG090120	1,20	6	50	1,80	0,10	46,93*
FMG090150	1,50	6	50	2,20	0,15	46,93*
FMG090200	2,00	6	50	2,20	0,15	42,53*

\*Jusqu'à fin de stock



70  
HRc

Réf. FMG08

CARBURE



CYLINDRIQUE

BLUE

2 Z



TOL D1  
-0,012

TOL D2  
h6

Micro Grain  
CARBURE

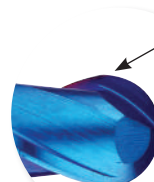
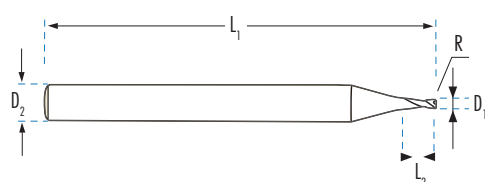

FMG08						
	D1 mm	D2 mm	L1 mm	L2 mm	R	€
FMG080040	0,40	6	50	0,40	0,20	68,68*
FMG080050	0,50	6	50	0,50	0,25	63,40*
FMG080060	0,60	6	50	0,60	0,30	58,13*
FMG080080	0,80	6	50	0,80	0,40	47,41*
FMG080100	1,00	6	50	1,00	0,50	44,64*
FMG080120	1,20	6	50	1,20	0,60	44,64*
FMG080150	1,50	6	50	1,50	0,75	44,64*
FMG080200	2,00	6	50	2,00	1,00	40,45*

\*Jusqu'à fin de stock



## FRAISES SPÉCIALES POUR ALUCOBOND

POINTE  
CARBURE

Réf. FFALUC

CARBURE

Réf. FFALUC...MDI

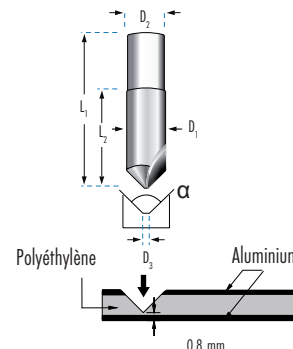
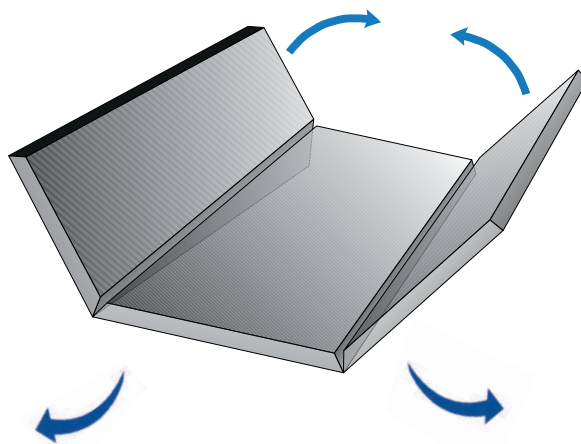
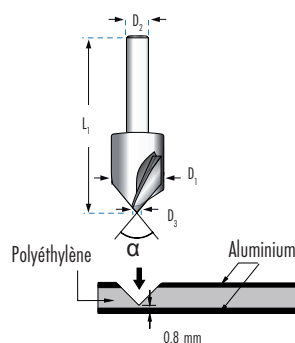

AVEC PLAQUETTE CARBURE

EN CARBURE

FFALUC

	D1 mm	D2 mm	D3 mm	L1 mm	α	€
FFALUC1600	16,00	8	2,5	55	90°	235,54
FFALUC1800	18,00	8	2,5	55	90°	248,06
FFALUC2000	20,00	8	2,5	55	90°	264,49
FFALUC1600-135	16,00	8	2,3	55	135°	235,54
FFALUC1800-135	18,00	8	2,3	55	135°	248,06
FFALUC2000-135	20,00	8	2,3	55	135°	264,49

FFALUC...MDI

	D1 mm	D2 mm	D3 mm	L1 mm	L2 mm	α	€
FFALUC1400MDI	14,00	14	2,5	50	14	90°	140,90
FFALUC1600MDI	16,00	16	2,5	50	16	90°	160,35
FFALUC1800MDI	18,00	18	2,5	50	18	90°	184,97
FFALUC1400MDI-135	14,00	14	0,5	50	14	135°	140,90 *
FFALUC1600MDI-135	16,00	16	0,5	50	16	135°	160,35 *
FFALUC1800MDI-135	18,00	18	0,5	50	18	135°	184,97 *

\*Jusqu'à fin de stock

**BLUE-MASTER®**  
by *celesa*



FRAISES À TROU

**FRAISES 3 TAILLES POUR RAINURER, HSSCo, DENTURE ALTERNÉE**

Réf. FF56

HSSCo

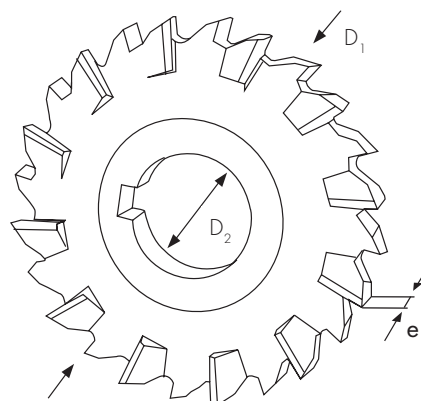
DIN  
885A

FF56				
D1 mm	e mm	D2 mm	Z	€
50	4,0	16	12	105,51
50	5,0	16	12	105,51
50	6,0	16	12	122,26
50	8,0	16	12	119,07
50	10,0	16	12	131,11
63	1,6	22	16	225,97
63	2,0	22	16	200,06
63	2,5	22	16	204,24
63	3,0	22	16	209,84
63	4,0	22	12	121,74
63	5,0	22	12	121,74
63	6,0	22	12	125,18
63	8,0	22	12	136,42
63	10,0	22	12	146,79
63	12,0	22	12	156,73
63	14,0	22	12	168,81
63	16,0	22	12	177,69
63	18,0	22	12	212,30
80	1,6	27	20	225,86
80	2,0	27	20	219,38
80	2,5	27	20	223,04
80	3,0	27	20	218,61
80	4,0	27	20	261,53
80	5,0	27	14	165,39
80	6,0	27	14	169,29
80	8,0	27	14	178,66
80	10,0	27	14	191,20
80	12,0	27	14	204,67
80	14,0	27	14	218,86
80	16,0	27	14	223,91
80	18,0	27	14	240,19
80	20,0	27	14	264,10

FF56				
D1 mm	e mm	D2 mm	Z	€
100	1,6	32	24	270,18
100	2,0	32	24	268,72
100	2,5	32	24	268,46
100	3,0	32	24	260,64
100	4,0	32	24	281,00
100	5,0	32	24	297,89
100	6,0	32	16	232,49
100	8,0	32	16	237,39
100	10,0	32	16	246,11
100	12,0	32	16	265,06
100	14,0	32	16	291,82
100	16,0	32	16	306,08
100	18,0	32	16	337,40
100	20,0	32	16	337,40
100	22,0	32	16	378,21
100	25,0	32	16	411,41
125	1,6	32	16	341,68
125	2,0	32	16	328,64
125	2,5	32	16	336,81
125	3,0	32	16	345,01
125	4,0	32	16	369,62
125	5,0	32	16	395,65
125	6,0	32	16	405,42
125	8,0	32	18	366,68
125	10,0	32	18	376,25
125	12,0	32	18	390,51
125	14,0	32	18	424,08
125	16,0	32	18	450,31
125	18,0	32	18	476,31
125	20,0	32	18	506,77
125	22,0	32	18	577,03
125	25,0	32	18	582,62
125	28,0	32	18	636,80

FF56				
D1 mm	e mm	D2 mm	Z	€
160	2,0	40	30	549,95
160	2,5	40	30	529,44
160	3,0	40	30	539,61
160	4,0	40	30	570,19
160	5,0	40	30	603,81
160	6,0	40	30	648,33
160	8,0	40	30	739,99
160	10,0	40	22	607,78
160	12,0	40	22	607,78
160	14,0	40	22	604,80
160	16,0	40	22	661,90
160	18,0	40	22	697,44
160	20,0	40	22	715,92
160	22,0	40	22	786,91
160	25,0	40	22	852,66
160	28,0	40	22	937,29
160	32,0	40	22	1.002,15
200	12,0	40	24	927,11
200	14,0	40	24	936,18
200	16,0	40	24	964,48
200	18,0	40	24	1.011,95
200	20,0	40	24	1.082,29
200	22,0	40	24	1.085,85
200	25,0	40	24	1.259,55
200	28,0	40	24	1.299,37
200	32,0	40	24	1.620,51

**FRAISES 3 TAILLES POUR RAINURER, HSSCo, DENTURE DROITE**



Réf. FF59

**HSSCo**

**DIN  
885B**

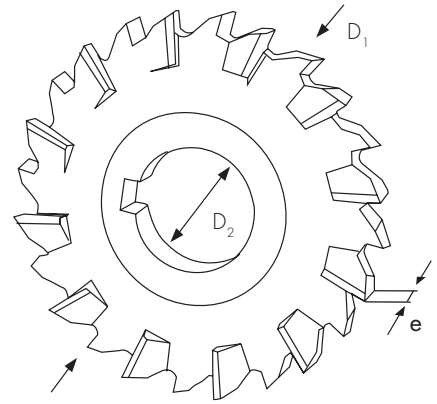
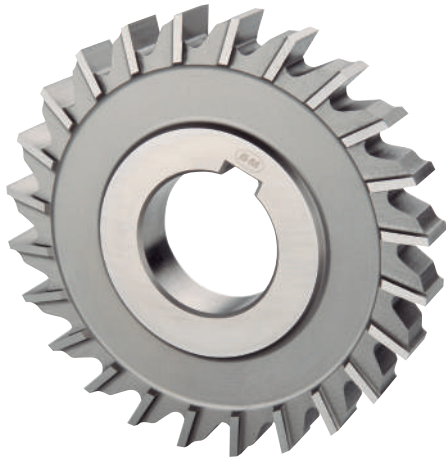

Fraises

Rose

FF59				
D1 mm	e mm	D2 mm	Z	€
50	4	16	16	105,18
50	5	16	16	105,18
50	6	16	16	121,90
50	8	16	16	118,72
50	10	16	16	130,73
63	4	22	18	122,53
63	5	22	18	122,53
63	6	22	18	124,16
63	8	22	18	134,98
63	10	22	18	145,25
63	12	22	18	155,57
63	14	22	18	167,54
63	16	22	18	177,22
63	18	22	18	211,66
80	5	27	20	164,82
80	6	27	20	169,17
80	8	27	20	178,52
80	10	27	20	190,57
80	12	27	20	204,04
80	14	27	20	218,20
80	16	27	20	223,87
80	18	27	20	240,15
80	20	27	20	264,05

FF59				
D1 mm	e mm	D2 mm	Z	€
100	6	32	22	230,13
100	8	32	22	236,66
100	10	32	22	245,32
100	12	32	22	264,20
100	14	32	22	290,88
100	16	32	22	308,17
100	18	32	22	337,33
100	20	32	22	337,33
100	22	32	22	377,07
100	25	32	22	412,48
125	8	32	24	366,46
125	10	32	24	376,02
125	12	32	24	390,28
125	14	32	24	423,84
125	16	32	24	445,60
125	18	32	24	476,16
125	20	32	24	506,63
125	22	32	24	576,88
125	25	32	24	582,47
125	28	32	24	636,60

FF59				
D1 mm	e mm	D2 mm	Z	€
160	10	40	28	607,60
160	12	40	28	607,60
160	14	40	28	604,64
160	16	40	28	661,70
160	18	40	28	697,25
160	20	40	28	715,72
160	22	40	28	786,68
160	25	40	28	852,43
160	28	40	28	937,02
160	32	40	28	1.001,86
200	12	40	30	926,84
200	14	40	30	935,92
200	16	40	30	964,22
200	18	40	30	1.011,67
200	20	40	30	1.081,98
200	22	40	30	1.085,55
200	25	40	30	1.259,21
200	28	40	30	1.299,01
200	32	40	30	1.620,07

**FRAISES MODULE À TAILLER LES ENGRENAGES**
**HSS**

Réf. 99RFM

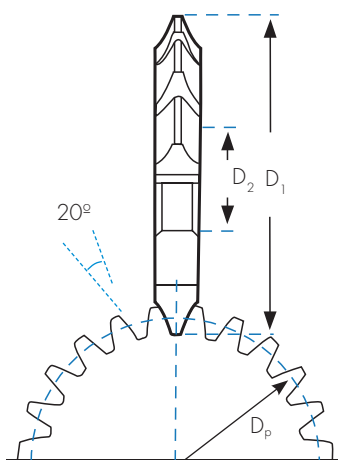
**NUMÉRO FRAISE / DENTS À TAILLER**

N°1	N°2	N°3	N°4	N°5	N°6	N°7	N°8	Set
12-13	14-16	17-20	21-25	26-34	35-54	55-134	135-∞	12-∞

NB: Le prix dépend du module, indépendamment du n° de dents à tailler

$$M = D_p / Z$$

$$M = P \times \pi$$

M=Module  
 D<sub>p</sub>=Diamètre primitif  
 Z=N° de dents  
 P=Passé (Dent+Vallée)

**99RFM**

MODULE FRAISE	D1 mm	D2 mm	€
0.50	40	16	131,56
0.70	40	16	131,56
0.75	40	16	131,56
0.80	40	16	131,56
1.00	50	16	131,56
1.25	50	16	131,56
1.50	56	22	135,10
1.75	56	22	135,10
2.00	63	22	135,10
2.25	63	22	158,33
2.50	63	22	158,33
2.75	71	27	158,33
3.00	71	27	158,33
3.25	71	27	208,94
3.50	80	27	208,94
3.75	80	27	208,94
4.00	80	27	208,94
4.50	90	32	286,37
5.00	90	32	286,37
6.00	100	32	362,61
7,00	100	32	362,61

**FRAISES À TROU À TENON, HSSCO**

Réf. FF87

**HSSCo**
**DIN 1880**



FINITION

Réf. FF88

**HSSCo**
**DIN 1880**

NR

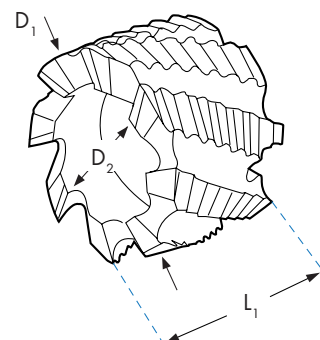
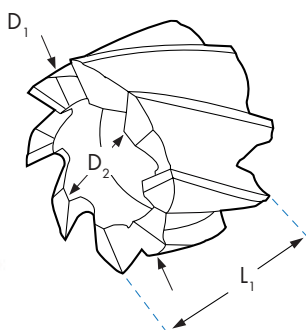
ÉBAUCHE

**FF87**

D1 mm	D2 mm	L1 mm	Z	€
40	16	32	8	138,75
50	22	36	8	190,90
63	27	40	8	260,85
80	27	45	10	369,21
100	32	50	12	594,39
125	40	56	14	954,54
160	50	63	16	1.705,96

**FF88**

D1 mm	D2 mm	L1 mm	Z	€
40	16	32	6	200,95
50	22	36	6	249,54
63	27	40	8	330,63
80	27	45	8	485,96
100	32	50	10	801,77
125	40	56	12	1.360,22
160	50	63	14	2.360,18

**FRAISES À TROU À TENON, HSSCO**



Réf. FF89

**HSSCo**

**DIN 884**



PLANER

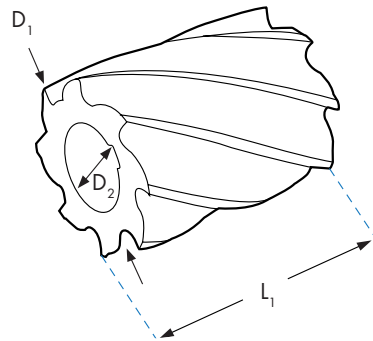
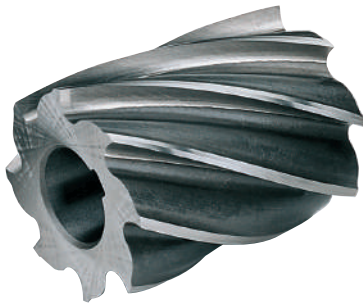

FF89					
D1 mm	D2 mm	L1 mm	Z	€	
50	22	63	8	173,84*	
50	22	80	8	259,14*	
63	27	50	8	228,11*	
63	27	70	8	277,53*	
80	32	63	8	384,48*	
100	40	70	10	598,18*	

\*Jusqu'à fin de stock

**FRAISES À PLANER À QUEUE**



Réf. FMF87

**HSSCo 8%**



FINITION

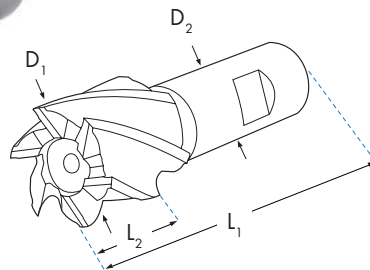

FMF87					
D1 mm	L2 mm	L1 mm	D2 mm	Z	€
30	30	90	20	6	202,26
35	30	90	20	6	232,12
40	32	95	25	8	289,30



Réf. FMF88

**HSSCo 8%**



ÉBAUCHE

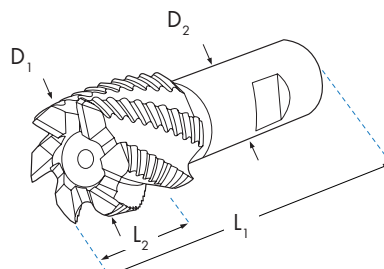

FMF88					
D1 mm	L2 mm	L1 mm	D2 mm	Z	€
30	30	90	20	6	233,82
35	30	90	20	6	299,55
40	32	95	25	8	366,95

**FRAISE 2 TAILLES ISOCÈLE HSSCo**

Réf. FF77

HSSCo

DIN  
847

Réf. FF78

HSSCo

DIN  
847

Réf. FF79

HSSCo

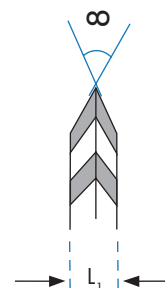
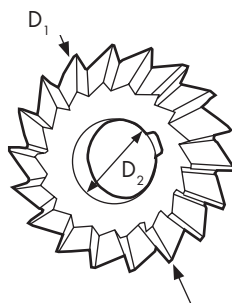
DIN  
847

FF77

D1 mm	D2 mm	L1 mm	∞	Z	€
50	16	8	45°	20	185,21
63	22	10	45°	22	220,30
80	27	12	45°	24	307,59
100	32	18	45°	26	384,54

FF78

D1 mm	D2 mm	L1 mm	∞	Z	€
50	16	10	60°	18	188,85
63	22	14	60°	20	224,63
80	27	18	60°	22	313,61
100	32	25	60°	24	392,08

FF79

D1 mm	D2 mm	L1 mm	∞	Z	€
50	16	14	90°	16	188,85
63	22	20	90°	18	224,63
80	27	22	90°	20	313,61
100	32	32	90°	22	392,08

**FRAISE D'ANGLE SIMPLE HSSCo**

Réf. FF91

HSSCo

DIN  
842

Réf. FF90

HSSCo

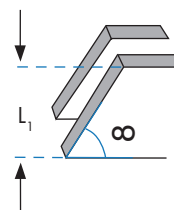
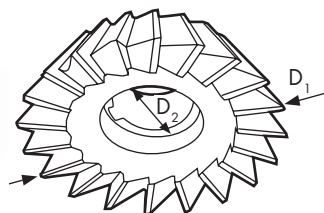
DIN  
842

FF91

D1 mm	D2 mm	L1 mm	∞	Z	€
40	10	13	50°	14	146,45
50	13	16	50°	16	180,60
63	16	20	50°	18	228,29
80	22	25	50°	20	328,91
100	27	32	50°	22	477,05
125	32	40	50°	24	787,77
160	40	50	50°	30	1.378,02

FF90

D1 mm	D2 mm	L1 mm	∞	Z	€
40	10	13	60°	14	143,60
50	13	16	60°	16	177,09
63	16	20	60°	18	223,86
80	22	25	60°	20	322,54
100	27	32	60°	22	467,77
125	32	40	60°	24	772,50
160	40	50	60°	30	1.351,27



**BLUE-MASTER®**  
by *celesa*



FRAISES  
POUR CLÉS

**LES OUTILS POUR SERRURIERS**  
**LA PLUS LARGE GAMME D'OUTILS DE COUPE POUR SERRURIERS**
**DIN**  
**338**
**POINTE**  
**CARBURE**

**BRILLANT**
**FORTE**

**BC7**
**BC7B**

Ø mm	L1 x L2 mm		€/U.		€/U.
6,00	93 x 57	BC70600	20,35	BC70600B	24,30

Foret DIN 338 à pointe en carbure pour les MÉTAUX DURS. Foret à haute dureté pour le perçage des MÉTAUX DURS dans la serrurerie. Vous le retrouvez à la page 51.

**DIN**  
**338**
**HSSCo**  
**5%**

**DORÉ**
**120**  
**Kg/mm²**

**BC5**
**BC5F**
**BC5B**

Ø mm	L1 x L2 mm		€/U.		€		€			
6,00	93 x 57	BC50600	10	4,97	BC50600F	1	5,53	BC50600B	1	6,37

Foret fabriqué en HSSCo selon la norme DIN 338 pour les métaux de 120 Kg/mm<sup>2</sup> de dureté. Foret de dureté élevée pour les UTILISATIONS GÉNÉRALES en serrurerie. Vous le retrouvez à la page 50.

**DIN**  
**338**
**POINTE**  
**CARBURE**

**BRILLANT**
**70 HRc**

**BC98**
**BC98B**

Ø mm	L1 x L2 mm		€/U.		€/U.
6,00	93 x 57	BC980600	16,84	BC980600B	20,79

Foret DIN 338 à pointe en carbure pour les MÉTAUX TRÈS DURS ou les MÉTAUX TREMPÉS. Foret à haute dureté pour le perçage des MÉTAUX DURS ou TREMPÉS dans la serrurerie. Vous le retrouvez à la page 51.

**CARBURE**
**TOL D1**  
**h7**
**TOL D2**  
**h6**

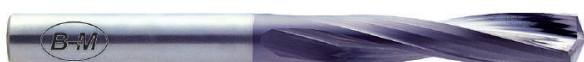
**TiAlN**
**HARDOX**  
**600**
**HAUTE**  
**PERFORMANCE**
**70**  
**HRc**

**BC85**
**BC85B**

Ø mm	L1 x L2 mm		€/U.		€/U.
6,00	75 x 35	BC850600	78,85	BC850600B	83,78

Foret carbure intégral pour métaux trempés, jusqu'à une dureté de 70 HRc. Foret de dureté extrême pour le perçage des MÉTAUX TREMPÉS dans la serrurerie. Vous le retrouvez à la page 70.

Sur demande, nous pouvons ajouter un système anti-vol électromagnétique à nos cartes, moyennant un surcoût de 0,09 € nets par carte, de manière aléatoire ou systématique.

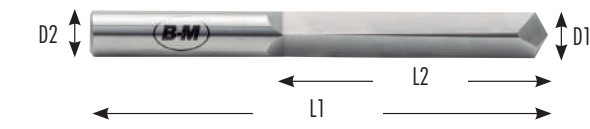
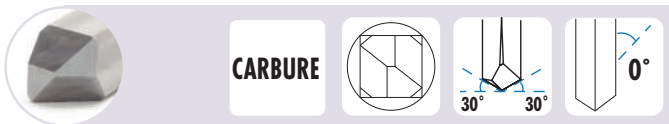
### FRET CARBURE POUR LE PERÇAGE DES CYLINDRES



Foret carbure intégral à section carrée pour le perçage de cylindres et de goupilles anti-perçage.  
LE FORET N°1 POUR LE PERÇAGE de CYLINDRES DE DURETÉ ÉLEVÉE dans la serrurerie.

D1 mm	D2 mm	L2 mm	L1 mm	1U.	€	BCC06X60MDB	€
6	6	33	60	BCC06X60MD	49,56	BCC06X60MDB	54,49

### FRAISE HÉMISPÉRIQUE EXTRA-LONGUE (SPÉCIALE SERRURIERS)

TYPE  
**C**

CARBURE



Fraises de serrurier, également connues sous le nom de VAMPIRE, en carbure intégral. Géométrie semi-sphérique dans des longueurs totales de 60 mm à 150 mm.  
La fraise idéale pour le FRAISAGE DE CYLINDRES: choisissez parmi la large gamme de dimensions celle qui convient le mieux à votre application.

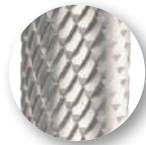
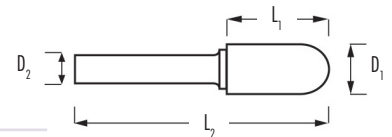

	D1 mm	D2 mm	L1 mm	L2 mm			1U.		1U.
3 mm. QUEUE	3.0	3	25.0	60	HSS	Y548TG2	21,25	Y548TG2B	25,27
	3.0	3	25.0	60	Monobloc	C30325-6	33,19	C30325-6B	37,16
6 mm. QUEUE	6.0	6	25.0	50	Monobloc	C60625-6	41,86	C60625-6B	45,85
	6.0	6	25.0	60	Monobloc	C60625-60-6	43,89	C60625-60-6B	47,87
	6.0	6	25.0	80	Monobloc	C60625-80-6	46,28	C60625-80-6B	50,27
	6.0	6	25.0	100	Monobloc	C60625-100-6	57,13	C60625-100-6B	61,11
	6.0	6	25.0	120	Monobloc	C60625-120-6	68,56	C60625-120-6B	72,54
	6.0	6	25.0	150	Monobloc	C60625-150-6	91,43	C60625-150-6B	95,41



### COFFRET DE FRAISES POUR SERRURIERS

RÉFÉRENCE	SETC60625
N° LIMES	4
CONTENU	C60625-100-6 / C60625-80-6 C60625-60-6 / C60625-6
P.V.P. €	182,36



**FRET CARBURE MOLETÉ SPÉCIAL POUR CYLINDRES**

Fraises

Rose

NEW

Réf. RCC

CARBURE



INOX



PHENOLIC



Spécialement conçu pour le perçage des cylindres de haute sécurité avec blindage.

Perçage de haute précision grâce à la pointe de centrage du foret.

Les 2 lèvres moletées rectifient la matière lors du fraisage et permettent un glissement optimal de l'outil.

Dipose de goujures qui atténuent les contraintes et assurent une excellente évacuation des copeaux.

A utiliser avec une meuleuse droite puissante. Si possible, avec un contrôle de la vitesse, entre 14.000-28.000 r.p.m. pour des performances optimales.

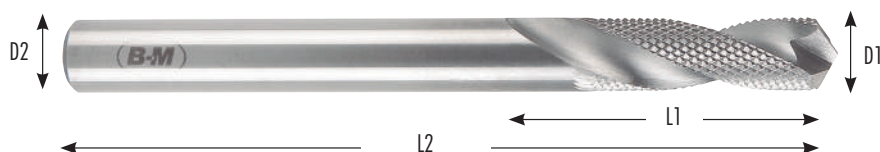

D1 mm	D2 mm	L1 mm	L2 mm		€
5.0	5	20.0	50	RCC0500	<b>38,46</b>
6.0	6	25.0	63	RCC0600	<b>45,74</b>
8.0	8	25.0	63	RCC0800	<b>76,15</b>
10.0	10	25.0	63	RCC1000	<b>96,74</b>

**FRAISE LIME ROTATIVE CYLINDRIQUE AVEC COUPE EN BOUT**
**TYPE**  
**A/E**

CARBURE



Fraises rotatives carbure de forme A/E (cylindrique à coupe frontale) et de forme C (cylindrique à bout hémisphérique).

Idéales pour le FRAISAGE DE CYLINDRES: choisissez parmi la large gamme de dimensions celle qui convient le mieux à votre application. Vous les retrouvez aux pages 335.



6 mm. QUEUE



D1 mm	L2 mm	D2 mm	L1 mm			1U.		1U.
6.0	25.0	6	50	Monobloc	A60625-6E	<b>37,33</b>	A60625-6EB	<b>41,31</b>



Sur demande, nous pouvons ajouter un système anti-volet électromagnétique à nos cartes, moyennant un surcoût de 0,09 € nets par carte, de manière aléatoire ou systématique.

**FRAISES POUR MACHINES DE REPRODUCTION DE CLÉS JMA**

FRAISES ISOCELÈS

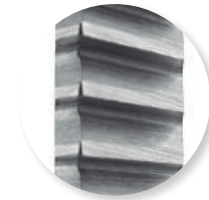

Réf. FLL99: Fraise isocèle 80x5x16 Z110 sans chanfrein latéral

Réf. FLLFP4

Réf. BM	Réf. JMA	TYPES DE MACHINES	MATÉRIEL	mm		mm	$\beta^\circ$	Z	mm	FLL	€
FLLFP1 (FLL02)	FP1	OREGON	HSSV	25	10	10	100°	60	0,1	FLL	102,56
FLLFP2W	FP2W	VIRGINIA	CARBURE	40	10	6	70°	70	0,1	FLL	403,37
FLLFP3 (FLL04)	FP3	KIS, SPRINT	HSSV	50	12	6	90°	80	0,15	FLL	124,82
FLLFP4 (FLL06)	FP4	KIS	HSSV	53	12,7	6,35	45/15°	72	0,6	FLL	128,73
FLLFP5	FP5	JMA	HSSV	57	12,7	5	90°	80	0,15	FLL	160,44
FLLFP6 (FLL09)	FP6	KIS, SPRINT	HSSV	60	12,7	5	84°	140	0,1	FLL	124,82
FLLFP1ECCO (FLL11)	FP11/ECCO-009	ECCO, ECCO-PLUS	HSSV	63	16	5	84°	80	1	FLL	119,41
FLLFP11W	FP11W	ECCO, ECCO-PLUS	CARBURE	63	16	5	84°	80	1	FLL	365,18
FLLFP12	FP12	TUCSON	HSSV	63	16	5	80°	80	1,25	FLL	128,73
FLLFP12W	FP12W	TUCSON	CARBURE	63	16	5	80°	80	1,25	FLL	394,30
FLLFP13	FP13	DALLAS	HSSV	63	16	5	84°	100	1	FLL	160,31
FLLCU14	CU14	ECCO, ECCO-PLUS	HSSV	63	16	5	80°	80	1,25	FLL	157,09
FLLFP16 (FLL13)	FP16	PROCEDURE	HSSV	70	16	5,25	76°	100	1	FLL	160,31
FLLFP16W	FP16W	PROCEDURE	CARBURE	70	16	5,25	76°	100	1	FLL	394,30
SLLP01	FP24 DAKOTA = P01	DAKOTA, ERREBI SARATOGA, NEVADA, DENVER, TITAN, VIENNA	HSSV	80	16	5	84°	110	1	FLL	103,50
SLLP01/120	FP24 DAKOTA=P01/120		HSSV	80	16	5	84°	120	1	FLL	105,47
FLLFP24 (FLL16)	FP24 ERREBI		HSSV	80	16	5	84°	110	1,25	FLL	98,46
FLLFP24W	FP24W ERREBI		CARBURE	80	16	5	84°	110	1,25	FLL	365,18
FLL99	FP24		HSSV	80	16	5	84°	110	0	FLL	113,76

AUTRES FRAISES POUR UTILISATION GÉNÉRALE

Réf. BM	TYPES DE MACHINES	MATÉRIEL	mm		mm	Z	FLL	€
FLL01	FLORA	HSSV	23	10	5	36	FLL	118,08
FLL03	YALE	HSSV	40	8	5	80	FLL	128,11
FLL05	NOVACLAU	HSSV	52	16	5	110	FLL	151,27
FLL07	KIS	HSSV	53	12,7	6	80	FLL	168,31
FLL08	KIS	HSSV	55	12	6	80	FLL	168,31
FLL10	NOVACLAU	HSSV	61	12,7	6,5	140	FLL	171,37
FLL11	NOVACLAU	HSSV	62	16	5	80	FLL	168,04
FLL12	NOVACLAU	HSSV	63	16	5	140	FLL	168,04
FLL14	WALKIN	HSSV	70	15	6,5	150	FLL	155,67
FLL15	LINCE	HSSV	70	13	7	88	FLL	173,09

FRAISES ISOCELÈS

**FRAISES POUR MACHINES DE REPRODUCTION DE CLÉS JMA**
**FRAISES CIRCULAIRES À COUPE LATÉRALE**

Réf. FLLFP19



Réf. BM	Réf. JMA	TYPES DE MACHINES	MATÉRIEL	mm			Z	FLL	€
				Ø	mm	mm			
FLL17		JMA-NOVACLAU-WALKIN	HSSV	35	12	3,15	50	<b>116,98</b>	
FLL18		JMA-NOVACLAU-WALKIN	HSSV	63	15	1,40	80	<b>143,05</b>	
FLLFP7	FP7	ECCO BIT, DETROIT	HSSV	63	16	1,25	80	<b>128,17</b>	
FLLFP7W	FP7W	ECCO BIT, DETROIT	CARBURE	63	16	1,25	80	<b>318,51</b>	
FLLFP8 (FLL19)	FP8	ECCO BIT, DETROIT	HSSV	63	16	1,4	80	<b>129,59</b>	
FLL20		JMA-NOVACLAU-WALKIN	HSSV	70	16	1,40	100	<b>150,07</b>	
FLLFP17	FP17	TITAN BIT, SARATOGA, YAKARTA	HSSV	80	16	1,25	100	<b>131,12</b>	
FLLFP17W	FP17W	TITAN BIT, SARATOGA, YAKARTA	CARBURE	80	16	1,25	100	<b>334,63</b>	
FLLFP18	FP18	ATLANTA, TOPEKA	HSSV	80	22	1,25	100	<b>133,74</b>	
FLLFP18W	FP18W	ATLANTA, TOPEKA	CARBURE	80	22	1,25	100	<b>334,63</b>	
FLLFP19 (FLL21)	FP19	SARATOGA, YAKARTA, TITAN BIT, DAKOTA	HSSV	80	16	1,4	100	<b>134,24</b>	
FLLFP19W	FP19W	SARATOGA, YAKARTA, TITAN BIT, DAKOTA	CARBURE	80	16	1,4	100	<b>313,42</b>	
FLLFP20 (FLL22)	FP20	ATLANTA, TOPEKA	HSSV	80	22	1,4	100	<b>134,24</b>	
FLLFP21 (FLL24)	FP21/SLLSG2	ATLANTA, TOPEKA, DUPLEX, KANSAS	HSSV	80	22	1,5	100	<b>137,96</b>	
FLLFP21W	FP21W	ATLANTA, TOPEKA, DUPLEX, KANSAS	CARBURE	80	22	1,5	100	<b>341,17</b>	

**FRAISES POUR CLÉS À PANNETON**



Réf. FLLFP22W



Réf. BM	Réf. JMA	TYPES DE MACHINES	MATÉRIEL	mm			Z	FLL	€
				Ø	mm	mm			
FLLFP9	FP9	ECCO BIT	HSSV	63	16	1	80	<b>84,50</b>	
FLLFP10	FP10	ECCO FORD, ECCO ABBLOY, PASADENA, NEBRASCA	HSSV	63	16	2,4	80	<b>84,50</b>	
FLLFP22	FP22	TITAN BIT, DAKOTA, SARATOGA	HSSV	80	16	1	100	<b>90,14</b>	
FLLFP22W	FP22W	TITAN BIT, DAKOTA, SARATOGA	CARBURE	80	16	1	100	<b>308,47</b>	
FLLFP23	FP23	DUPLEX, ATLANTA, TOPEKA	HSSV	80	22	1	100	<b>93,39</b>	
FLLFP23W	FP23W	DUPLEX, ATLANTA, TOPEKA	CARBURE	80	22	1	100	<b>308,47</b>	
FF68801416100CO	-	TITAN, DAKOTA, SARATOGA, YAKARTA	HSSCo	80	16	1,4	100	<b>90,79</b>	
FLLFP26 (FLL23)	FP26	G, SENNA, DAKOTA, SARATOGA, YAKARTA	HSSV	80	16	1,5	100	<b>94,68</b>	
FLLFP26W	FP26W	G, SENNA, DAKOTA, SARATOGA,	CARBURE	80	16	1,5	100	<b>312,79</b>	

**FRAISES POUR MACHINES DE REPRODUCTION DE CLÉS JMA**

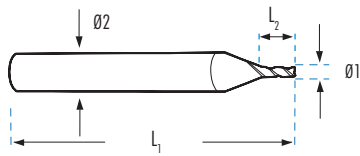
**FRAISES À RAINURER POUR CLÉS**



Réf. FLLF3



Réf. BM	Réf. JMA	TYPES DE MACHINES	MATÉRIEL	Ø1 mm	L1 mm	Ø2 mm	L2 mm	Z	FLL
									€
FLLF3Z3	(FLL32)	≈ F3	HSSCo	1,5	45	6	3	3	44,50
FLLF3	(FLL44)	F3	HSSCo	1,5	45	6	3	2	41,65
FLLF3W	(FLL45)	F3W	CARBURE	1,5	45	6	3	2	135,41
FLLF33	(FLL53)	F33	HSSCo	2	45	6	4	3	40,21
FLL11Z3	(FLL33)	≈ F11	HSSCo	2,5	45	6	5	3	40,21
FLLF11	(FLL48)	F11	HSSCo	2,5	45	6	5	2	35,99
FLLF11W	(FLL49)	F11W	CARBURE	2,5	45	6	5	2	102,50
FLLF17	(FLL34)	F17	HSSCo	3	45	6	6	3	40,21
FLLF8Z3	(FLL35)	≈ F8	HSSCo	4	45	6	6	3	46,80
FLLF8	(FLL46)	F8	HSSCo	4	45	6	7	2	41,65
FLLF8W	(FLL47)	F8W	CARBURE	4	45	6	6	2	127,08
FLLF77	(FLL36)	-	HSSCo	5	45	6	7	3	46,80
FLLF78	(FLL37)	-	HSSCo	6	45	6	8	3	46,80
FLLF78W	(FLL54)	-	CARBURE	6	45	6	8	3	102,50
FLLF78WZ4	(FLL55)	-	CARBURE	6	45	6	8	4	102,50

**FRAISES POUR CLÉS À POINTS POUR MACHINES JMA ET SILCA**

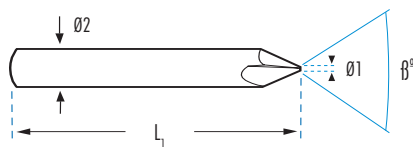

Réf. FLLF1

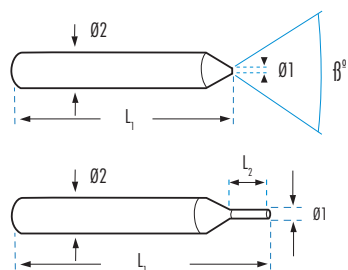

Réf. BM	Réf. JMA	TYPES DE MACHINES	MATÉRIEL	β°	Ø1 mm	L1 mm	Ø2 mm	Z	FLL
									€
FLLF82	-	ALBANY	HSSCo	82°	0,9	45	6	2	27,42
FLLF1	(FLL43)	ARIZONA	HSSCo	90°	0,8	45	6	2	27,42
FLLF1W	(FLL42)	COLUMBIA	CARBURE	90°	0,8	45	6	2	84,92
FLLF5	(FLL52)	DAKAR	HSSCo	90°	0,9	45	6	2	27,42
FLLF5W	(FLL42)	DAKAR EXPRESS	CARBURE	90°	0,9	45	6	2	84,92
FLLF95	-	DAY T-COL	HSSCo	95°	0,9	45	6	2	27,42
FLLF13	(FLL50)	DAYTONA	HSSCo	100°	0,8	45	6	2	27,42
FLLF13W	(FLL51)	DAYTONA	CARBURE	100°	0,8	45	6	2	79,45
FLLF105	-	X CODE	HSSCo	105°	0,9	45	6	2	27,42

**FRAISES POUR MACHINES DE REPRODUCTION DE CLÉS JMA**
**PALPEURS**

Réf. FLLP1



Réf. FLLP3



Réf. BM	Réf. JMA	TYPES DE MACHINES	MATÉRIEL	 β°	Ø <sub>1</sub> mm	L <sub>1</sub> mm	Ø <sub>2</sub> mm	L <sub>2</sub> mm	FLL
									€
FLLP1	(PLL38)	P1	HSSV	90°	0,8	45	6	-	<b>22,32</b>
FLLP3	(PLL32)	P3	HSSV	-	1,5	45	6	4	<b>39,48</b>
FLLP5		P5	HSSV	90°	0,9	45	6	-	<b>22,32</b>
FLLP8	(PLL35)	P8	HSSV	-	4	45	6	7	<b>39,48</b>
FLLP11	(PLL33)	P11	HSSV	-	2,5	45	6	4	<b>39,48</b>
FLLP13	(PLL50)	P13	HSSV	100°	0,8	45	6	-	<b>22,32</b>
FLLP17	(PLL34)	P17	HSSV	-	3	45	6	6	<b>39,48</b>
FLLP52	(PLL52)	-	HSSV	90°	0,9	45	6	-	<b>22,32</b>
FLLP77	(PLL36)	-	HSSV	-	5	45	6	7	<b>39,48</b>
FLLP78	(PLL37)	-	HSSV	-	6	45	6	8	<b>39,48</b>

**FRAISES KEY LINE**

Réf. BM	Réf. JMA	TYPES DE MACHINES	MATÉRIEL	 β°	Ø <sub>1</sub> mm	L <sub>1</sub> mm	Ø <sub>2</sub> mm	L <sub>2</sub> mm	€
									€
V001	-	KEY LINE	CARBURE	90°	0,4	32	4	-	<b>144,98</b>
V003	-		CARBURE	-	2,5	32	4	5	<b>144,98</b>
V004	-		CARBURE	82°	0,5	32	4	-	<b>144,98</b>
V007	-		CARBURE	100°	0,4	32	4	-	<b>144,98</b>
V012	-		CARBURE	-	1,5	32	4	4	<b>178,26</b>



**FRAISES POUR MACHINES DE REPRODUCTION DE CLÉS SILCA**

**FRAISES ISOCÈLES**

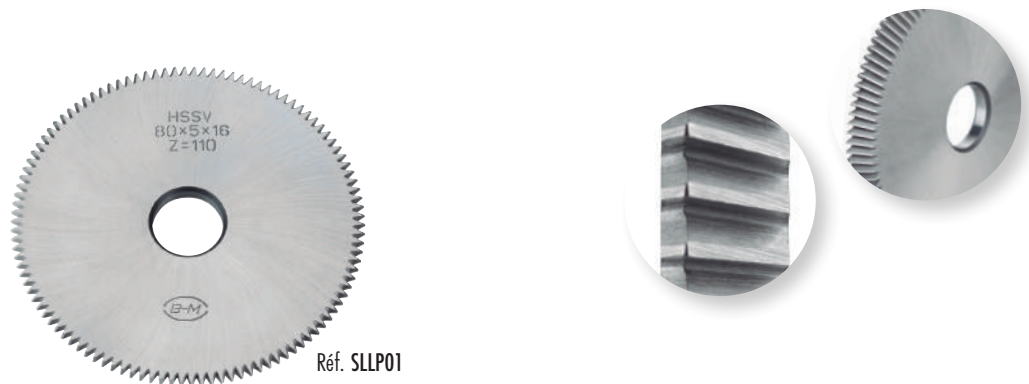

Réf. SLLP01

Réf. BM	Réf. SILCA	TYPES DE MACHINES	MATÉRIEL	DIMENSIONS					Z	SLL	€
				mm	mm	mm	β°	mm			
SLL01F	O1F	FUTURA PRO	CARBURE	60,4	9,52	3,05	40	110	0	160,12	
SLLU01	U01	UNOCODE/ULTRACODE	HSSV	60,4	9,52	5,25	80	72	0,5	128,62	
SLLU01W	U01W	UNOCODE/ULTRACODE	CARBURE	60,4	9,52	5,25	80	72	0,5	410,92	
SLLP21	P21	SILCA DELTA	HSSV	60,4	9,52	5,25	84	72	0,5	116,01	
SLLP01	P01	BRAVO/POKER/REKORD BRAVO SUPER/SUPER MASTER	HSSV	80	16	5	84	110	1	103,50	
SLLP01/120	P01/120		HSSV	80	16	5	84	120	1	105,47	
SLLP01W	P01W		CARBURE	80	16	5	84	110	1	339,09	

**FRAISES CIRCULAIRES À COUPE LATÉRALE**



Réf. SLLSG2

Réf. BM	Réf. SILCA	TYPES DE MACHINES	MATÉRIEL	DIMENSIONS			Z	SLL	€
				mm	mm	mm			
SLLY2KW	Y2KW	DELTA	CARBURE	63	16	1,35	80	310,73	
SLLSG19	SG19	DELTA	HSSV	64,6	9,52	1,5	40	87,81	
SLLSG19W	SG19W	DELTA	CARBURE	64,6	9,52	1,5	40	295,76	
SLLSG18	SG18	DELTA	HSSV	64,6	9,52	2,4	40	87,81	
SLLSG18W	SG18W	DELTA	CARBURE	64,6	9,52	2,4	40	295,76	
SLLSG6	SG6	LANCER	HSSV	80	22	1,3	100	90,24	
SLLSG6W	SG6W	LANCER	CARBURE	80	22	1,3	100	310,73	
SLLSG2	SG2	TARGA/TECH3/TECHNICA	HSSV	80	22	1,5	100	90,24	
SLLSG2W	SG2W	TARGA/TECH3/TECHNICA	CARBURE	80	22	1,5	100	310,73	
SLLFSC4-CAW	FSCL4-CAW	DELTA	CARBURE	80	22	1,8	100	323,01	

**FRAISES POUR MACHINES DE REPRODUCTION DE CLÉS SILCA**
**FRAISES POUR CLÉS À PANNETON**

Réf. SLLSG7W



Réf. BM	Réf. SILCA	TYPES DE MACHINES	MATÉRIEL	mm			Z	SLL	€
SLLSG14W	SG14W	DELTA	CARBURE	60,4	9,52	1,14	80	248,49	
SLLGB1	GB1	ULTRACODE / UNOCODE	HSSV	60,4	9,52	1,7	66	91,16	
SLL05	05	UNOCODE/ULTRACODE	HSSV	60,4	9,52	1,8	68	91,16	
SLL05W	05W	UNOCODE/ULTRACODE	CARBURE	60,4	9,52	1,8	68	260,78	
SLLCU-15C	CU-15C	OPERA / TARGA	CARBURE	63	16	1,5	80	339,67	
SLLSG17	SG17	DELTA	HSSV	64,6	9,52	1,8	70	91,16	
SLLSG17W	SG17W	DELTA	CARBURE	64,6	9,52	1,8	70	286,44	
SLLSG13	SG13	UNOCODE / DELTA	HSSV	64,6	9,52	2	70	91,16	
SLLSG13W	SG13W	UNOCODE / DELTA	CARBURE	64,6	9,52	2	70	339,67	
SLL06	06	UNOCODE/ULTRACODE	HSSV	64,6	9,52	2,4	70	91,16	
SLL06W	06W	UNOCODE/ULTRACODE	CARBURE	64,6	9,52	2,4	70	276,96	
SLLSG3	SG3	OPERA / TARGA/TECH3	HSSV	80	22	1	100	86,72	
SLLSG3W	SG3W	OPERA / TARGA/TECH3	CARBURE	80	22	1	100	286,44	
SLLSG4	SG4	OPERA / TARGA/TECH3	HSSV	80	22	1,25	100	86,72	
SLLSG4W	SG4W	OPERA / TARGA/TECH3	CARBURE	80	22	1,25	100	286,44	
SLLSG5	SG5	LANCER	HSSV	80	22	1,3	100	86,72	
SLLSG5W	SG5W	LANCER	CARBURE	80	22	1,3	100	286,44	
SLLSG7	SG7	OPERA / TARGA	HSSV	80	22	1,4	100	86,72	
SLLSG7M35	SG7M35	OPERA / TARGA	HSSCo	80	22	1,4	100	111,02	
SLLSG7W	SG7W	LANCER	CARBURE	80	22	1,4	100	286,44	
SLLSG1	SG1	OPERA / TARGA/TECH3	HSSV	80	22	1,5	100	86,72	
SLLSG1W	SG1W	OPERA / TARGA/TECH3	CARBURE	80	22	1,5	100	286,44	
SLLSG8	SG8	TECH3 / TECHNICA	HSSV	80	22	1,75	100	86,72	
SLLSG10	SG10	LANCER	HSSV	80	22	2	100	86,72	
SLLSG10W	SG10W	LANCER/ OPERA / TARGA	CARBURE	80	22	2	100	298,58	
SLLSG11	SG11	SILCA GT40	HSSV	80	22	2,3	100	86,72	
SLLSG12	SG12	TARGA/TECH3/TECHNICA/OPERA	HSSV	80	22	2,5	100	86,72	
SLLSG58400	SG58400	DELTA	CARBURE	80	22	4	100	274,28	
SLLPL1	PL1	PRIMA LASER	HSSV	100	22	1	100	149,62	
SLLPL1W	PL1W	PRIMA LASER	CARBURE	100	22	1	100	383,91	
SLLPL1,25	PL1,25	PRIMA LASER	HSSV	100	22	1,25	100	149,62	
SLLPL1,25W	PL1,25W	PRIMA LASER	CARBURE	100	22	1,25	100	366,10	
SLLPL1,5	PL1,5	PRIMA LASER	HSSV	100	22	1,5	100	149,62	
SLLPL1,5W	PL1,5W	PRIMA LASER	CARBURE	100	22	1,5	100	366,10	
SLLPL1,7W	PL1,7W	PRIMA LASER	CARBURE	100	22	1,7	100	377,32	
SLLPL2	PL2.0	PRIMA LASER	HSSV	100	22	2	100	149,62	
SLLPL2W	PL2.0W	PRIMA LASER	CARBURE	100	22	2	100	377,32	

**FRAISES POUR MACHINES DE REPRODUCTION DE CLÉS SILCA**

**FRAISES POUR CLÉS À POINTS**

**MATRIX**



Réf. SLLF1W

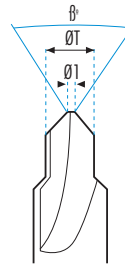
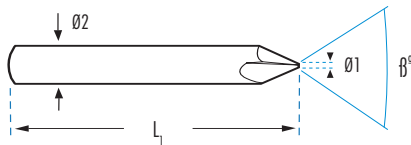

Réf. SLLF19-CAZ1  
Réf. SLLF19  
Réf. SLLF43  
Réf. SLLF21  
Réf. SLLF25

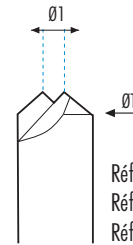

Réf. SLLF12B  
Réf. SLLF15  
Réf. SLLF37



Réf. BM	Réf. SILCA	UNIV.	TYPES DE MACHINES	MATÉRIEL	β°	Ø1 mm	L1 mm	Ø2 mm	Z	SLL
										€
SLLF1Z1	F1	FLLF1	MATRIX	HSSV	90°	0,7	48	6	1	58,00
SLLF1	F1	FLLF1	MATRIX	HSSV	90°	0,7	48	6	2	58,00
SLLF1W	F1W	FLLF1W	MATRIX	CARBURE	90°	0,7	48	6	1	103,69
SLLF4	F4	FLLF1	MATRIX	HSSV	90°	0,4	48	6	1	58,00
SLLF5	F5	FLLF5	MATRIX	HSSV	90°	0,9	48	6	1	58,00
SLLF6	F6	FLLF105	MATRIX	HSSV	106°	1	48	6	1	58,00
SLLF7	F7	FLLF82	MATRIX	HSSV	72°	0,8	48	6	2	58,02
SLLF12A	F12A	FLLF13	MATRIX	HSSV	100°	0,4	48	6	1	58,00
SLLF12B	F12B	FLLF1	MATRIX	HSSV	90°	8 x 1,8*	48	6	2	58,00
SLLF13	F13	FLLF1	MATRIX	HSSV	90°	0,77	48	6	1	58,00
SLLF14	F14	FLLF5	MATRIX	HSSV	90°	0,9	48	6	1	58,00
SLLF15	F15	FLLF1	MATRIX	HSSV	90°	8 x 0,8*	48	6	1	66,47
SLLF19	F19	FLLF1	MATRIX	HSSCo	90°	2,2 x 0,6*	48	6	1	58,02
SLLF19-CAZ1	F19-CA	FLLF1W	MATRIX	CARBURE	90°	2,2 x 0,6*	48	6	1	103,69
SLLF20	F20	FLLF1	MATRIX	HSSV	90°	0,45	48	6	2	58,00
SLLF21	F21	FLLF82	MATRIX	HSSCo	85°	3,2 x 0,8*	48	6	1	66,47
SLLF23	F23	FLLF1	MATRIX	HSSV	90°	1,5	48	6	2	66,47
SLLF24	F24	FLLF13	MATRIX	HSSV	100°	1,3	48	6	1	58,00
SLLF25	F25	FLLF1	MATRIX	HSSV	90°	3,5 x 0,65*	48	6	1	58,00
SLLF26	F26	FLLF82	MATRIX	HSSV	82°	0,8	48	6	1	58,00
SLLF27-CA	F27-CA	-	MATRIX	CARBURE	60°	2,4 x 1,9*	48	6	1	138,52
SLLF28	F28	-	MATRIX	HSSV	76°	0,76	48	6	1	58,00
SLLF29	F29	-	MATRIX	HSSV	76°	1,9 x 0,76*	48	6	1	58,00
SLLF34	F34	-	MATRIX	HSSV	50°	1,5	48	6	1	58,00
SLLF34-CAZ1	F34-CA	-	MATRIX	CARBURE	50°	1,5	48	6	1	103,69
SLLF37	F37	FLLF1	MATRIX	HSSV	90°	6 x 2,1*	48	6	2	66,47
SLLF39	F39	FLLF1	MATRIX	HSSV	90°	0,6	48	6	2	70,45
SLLF42	F42	FLLF13	MATRIX	HSSV	100°	0,7	48	6	1	58,00
SLLF43	F43	FLLF1	MATRIX	HSSCo	90°	1	48	6	1	58,00
SLLF45	F45	-	MATRIX	HSSV	130°	0,56	48	6	1	58,02
SLLF46	F46	FLLF13	MATRIX	HSSV	100°	0,65	48	6	1	58,02
SLLF49	F49	FLLF95	MATRIX	HSSV	95°	0,8	48	6	1	66,47
SLLF50	F50	FLLF13	MATRIX	HSSV	100°	0,5	48	6	1	66,47
SLLF52-CA	F52-CA	-	MATRIX	CARBURE	54°	0,86	48	6	2	58,00
SLLF59	F59	FLLF1	MATRIX	HSSV	90°	0,8	48	6	2	58,00
SLL01D	01D	-	FUTURA PRO	CARBURE	90°	0,4	30	6	2	65,12
SLL02D	02D	-	FUTURA PRO	CARBURE	100°	0,4	30	6	2	65,12

\* Ø1 x Ø1

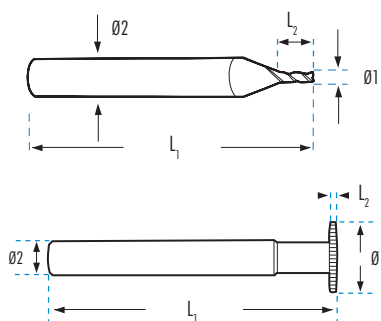
**FRAISES POUR MACHINES DE REPRODUCTION DE CLÉS SILCA**
**FRAISES À RAINURER POUR CLÉS**
**MATRIX**

Réf. SLLF3

**SLL**

Réf. BM	Réf. SILCA	TYPES DE MACHINES	MATÉRIEL	Ø1 mm	L1 mm	Ø2 mm	L2 mm	Z	€
SLLF3	F3	MATRIX	HSSV	1,5	48	6	2	3	58,00
SLLF8	F8	MATRIX	HSSV	4	48	6	13	3	58,00
SLLF11	F11	MATRIX	HSSV	2,5	48	6	7	3	58,00
SLLF22	F22	MATRIX	HSSV	2,5	42	6	6	3	58,00
SLLF30	F30	MATRIX	HSSV	3	48	6	6	3	58,00
SLLF30Z2	F30	MATRIX	HSSV	3	48	6	6	2	68,17
SLLF44	F44	MATRIX	HSSV	2	40	6	6	3	58,00
SLL01L	O1L	FUTURA PRO	CARBURE	2,5	30	6	3	3	65,12
SLL02L	O2L	FUTURA PRO	CARBURE	2	30	6	3	3	65,12

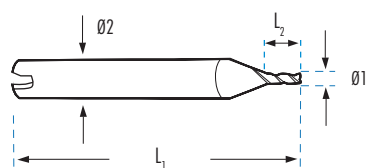
**FRAISES À RAINURER POUR CLÉS**
**QUATTROCODE / TRIAX-E**

Réf. SLLW133

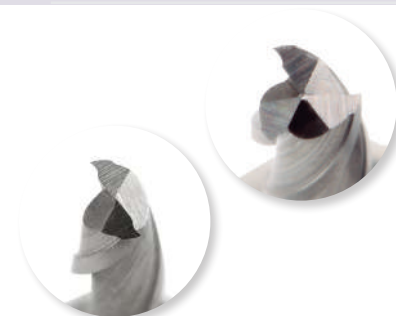
**SLL**

Réf. BM	Réf. SILCA	TYPES DE MACHINES	MATÉRIEL	Ø1 mm	L1 mm	Ø2 mm	L2 mm	Z	€
SLLW101	W101	QUATTROCODE / TRIAX-E	CARBURE	2,5	40	6	6	3	132,31
SLLW114	W114	QUATTROCODE / TRIAX-E	CARBURE	2	40	6	6	3	132,33
SLLW117	W117	QUATTROCODE / TRIAX-E	CARBURE	5	48	6	R1	4	107,39
SLLW129	W129	QUATTROCODE / TRIAX-E	CARBURE	3	40	6	6	3	132,31
SLLW131	W131	QUATTROCODE / TRIAX-E	CARBURE	6	40	6	5	3	97,67
SLLW133	W133	QUATTROCODE / TRIAX-E	CARBURE	1,5	40	6	3	3	144,50
SLLW134	W134	QUATTROCODE / TRIAX-E	CARBURE	4	40	6	7	3	132,33
SLLW219	W219	QUATTROCODE / TRIAX-E	CARBURE	1,2	40	6	2	3	132,31
SLLW235	W235	QUATTROCODE / TRIAX-E	CARBURE	1,1	40	6	2	3	132,28
SLLW268	W268	QUATTROCODE / TRIAX-E	CARBURE	1,5	40	6	6	2	132,40

**FRAISES POUR MACHINES DE REPRODUCTION DE CLÉS SILCA**

FRAISES POUR CLÉS À POINTS

QUATTROCODE / TRIAX-E



Réf. SLLW103

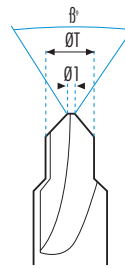
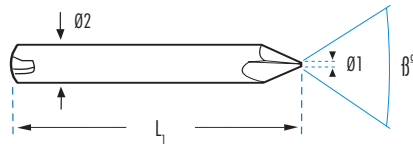

- Réf. SLLW115
- Réf. SLLW128
- Réf. SLLW135
- Réf. SLLW145
- Réf. SLLW210

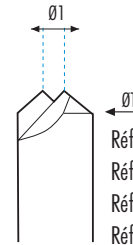

- Réf. SLLW111
- Réf. SLLW126
- Réf. SLLW127
- Réf. SLLW139



Ref. BM	Ref. SILCA	TYPES DE MACHINES	MATÉRIEL	$\beta^\circ$	$\varnothing_1$ mm	$L_1$ mm	$\varnothing_2$ mm	Z	SLL €
SLLW102	W102	QUATTROCODE / TRIAX-E	CARBURE	106°	1	40	6	2	92,86
SLLW103	W103/W299	QUATTROCODE / TRIAX-E	CARBURE	90°	0,8	40	6	2	92,86
SLLW104	W104	QUATTROCODE / TRIAX-E	CARBURE	90°	1,2	40	6	2	92,86
SLLW105	W105	QUATTROCODE / TRIAX-E	CARBURE	90°	0,7	40	6	2	92,86
SLLW106	W106	QUATTROCODE / TRIAX-E	CARBURE	90°	0,6	40	6	2	92,86
SLLW107	W107	QUATTROCODE / TRIAX-E	CARBURE	90°	0,9	40	6	2	92,86
SLLW108	W108	QUATTROCODE / TRIAX-E	CARBURE	82°	0,9	40	6	2	92,86
SLLW109	W109	QUATTROCODE / TRIAX-E	CARBURE	110°	0,4	40	6	2	92,86
SLLW110	W110	QUATTROCODE / TRIAX-E	CARBURE	100°	0,6	40	6	2	92,86
SLLW111	W111	QUATTROCODE / TRIAX-E	CARBURE	96°	8x2,75*	40	6	2	104,32
SLLW112	W112	QUATTROCODE / TRIAX-E	CARBURE	60°/0°	1,5	40	6	2	93,46
SLLW113	W113	QUATTROCODE / TRIAX-E	CARBURE	100°	0,76	40	6	2	92,86
SLLW115	W115	QUATTROCODE / TRIAX-E	CARBURE	54°	4x0,86*	40	6	1	124,49
SLLW116	W116	QUATTROCODE / TRIAX-E	CARBURE	90°	1	40	6	2	92,86
SLLW118	W118	QUATTROCODE / TRIAX-E	CARBURE	120°	0,6	40	6	2	92,86
SLLW119	W119	QUATTROCODE / TRIAX-E	CARBURE	85°	0,3	40	6	2	92,86
SLLW121	W121	QUATTROCODE / TRIAX-E	CARBURE	86°	0,05	48	6	3	129,21
SLLW122	W122	QUATTROCODE / TRIAX-E	CARBURE	90°	0,55	40	6	2	111,44
SLLW123	W123	QUATTROCODE / TRIAX-E	CARBURE	76°	0,9	40	6	2	92,86
SLLW124	W124	QUATTROCODE / TRIAX-E	CARBURE	90°	8x0,8*	48	6	3	178,01
SLLW126	W126	QUATTROCODE / TRIAX-E	CARBURE	80°	3,3	48	6	2	111,44
SLLW127	W127	QUATTROCODE / TRIAX-E	CARBURE	80°	2,1	48	6	2	111,44
SLLW128	W128	QUATTROCODE / TRIAX-E	CARBURE	90°	4x0,55*	48	6	1	124,49
SLLW130	W130	QUATTROCODE / TRIAX-E	CARBURE	90°	1,4	40	6	2	125,01
SLLW132	W132	QUATTROCODE / TRIAX-E	CARBURE	60°	2	40	6	1	124,49
SLLW135	W135	QUATTROCODE / TRIAX-E	CARBURE	90°	4x0,55*	40	6	2	124,42
SLLW136	W136	QUATTROCODE / TRIAX-E	CARBURE	76°	2,23	40	6	1	124,49
SLLW138	W138	QUATTROCODE / TRIAX-E	CARBURE	90°	4x0,7*	48	6	2	92,86
SLLW139	W139	QUATTROCODE / TRIAX-E	CARBURE	60°/50°	0,9	40	6	2	138,52
SLLW142	W142	QUATTROCODE / TRIAX-E	CARBURE	100°	1,2	40	6	2	92,86
SLLW145	W145	QUATTROCODE / TRIAX-E	CARBURE	90°	3,2x0,8*	48	6	2	124,42
SLLW210	W210	QUATTROCODE / TRIAX-E	CARBURE	90°	5x1,05*	40	6	3	186,33
SLLW213	W213	QUATTROCODE / TRIAX-E	CARBURE	90°	0,95*	40	6	2	140,21
SLLW221	W221	QUATTROCODE / TRIAX-E	CARBURE	90°	0,5	40	6	2	125,01
SLLW225	W225	QUATTROCODE / TRIAX-E	CARBURE	90°	1	40	6	2	125,01
SLLW238	W238	QUATTROCODE / TRIAX-E	CARBURE	90°	0,8	40	6	2	92,86
SLLW261	W261	QUATTROCODE / TRIAX-E	CARBURE	1,1	3x1,5*	48	6	2	140,21
SLLW255	W255	QUATTROCODE / TRIAX-E	CARBURE	90°	4x0,8*	48	6	2	125,01
SLLW293	W293	QUATTROCODE / TRIAX-E	CARBURE	90°	0,85	40	6	2	125,01
SLLW299	W299	QUATTROCODE / TRIAX-E	CARBURE	90°	3x0,80	40	6	2	100,72

\*  $\varnothing_1 \times \varnothing_2$

## FRAISES POUR MACHINES DE REPRODUCTION DE CLÉS SILCA

## FRAISES POUR CLÉS À POINTS

## QUATTROCODE / TRIAX-E

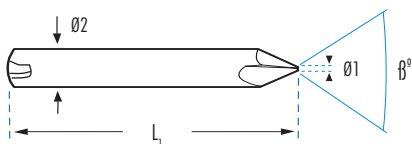

Réf. SLLW103Z1

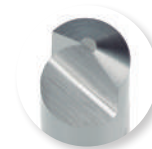

Réf. BM	Réf. SILCA	TYPES DE MACHINES	MATÉRIEL	$\beta^\circ$	$\varnothing_1$ mm	$L_1$ mm	$\varnothing_2$ mm	Z	€
SLLW102Z1	W102 Z1	QUATTROCODE / TRIAX-E	CARBURE	106°	1	40	6	2	93,46
SLLW103Z1	W103 Z1	QUATTROCODE / TRIAX-E	CARBURE	90°	0,8	40	6	2	93,46
SLLW104Z1	W104 Z1	QUATTROCODE / TRIAX-E	CARBURE	90°	1,2	40	6	2	93,46
SLLW105Z1	W105 Z1	QUATTROCODE / TRIAX-E	CARBURE	90°	0,7	40	6	2	93,46
SLLW106Z1	W106 Z1	QUATTROCODE / TRIAX-E	CARBURE	90°	0,6	40	6	2	93,46
SLLW107Z1	W107 Z1	QUATTROCODE / TRIAX-E	CARBURE	90°	0,9	40	6	2	93,46
SLLW108Z1	W108 Z1	QUATTROCODE / TRIAX-E	CARBURE	82°	0,9	40	6	2	93,46
SLLW109Z1	W109 Z1	QUATTROCODE / TRIAX-E	CARBURE	110°	0,4	40	6	2	93,46
SLLW113Z1	W113 Z1	QUATTROCODE / TRIAX-E	CARBURE	100°	0,76	40	6	2	93,46
SLLW116Z1	W116 Z1	QUATTROCODE / TRIAX-E	CARBURE	90°	1	40	6	2	93,46
SLLW118Z1	W118 Z1	QUATTROCODE / TRIAX-E	CARBURE	120°	0,6	40	6	2	93,46
SLLW119Z1	W119 Z1	QUATTROCODE / TRIAX-E	CARBURE	85°	0,3	40	6	2	93,46
SLLW122Z1	W122 Z1	QUATTROCODE / TRIAX-E	CARBURE	90°	0,55	40	6	2	93,46
SLLW123Z1	W123 Z1	QUATTROCODE / TRIAX-E	CARBURE	76°	0,9	40	6	2	93,46
SLLW146Z1	W146 Z1	QUATTROCODE / TRIAX-E	CARBURE	90°	0,25	40	6	1	93,46

## FRAISES POUR CLÉS À POINTS

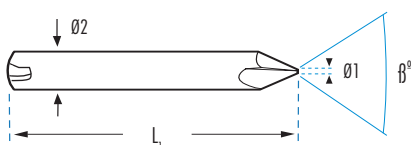

Réf. SLLH103

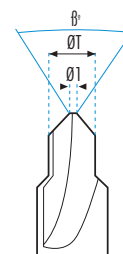
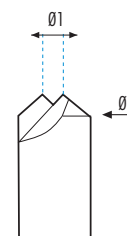

Réf. SLLH115

Réf. SLLH111  
Réf. SLLH126  
Réf. SLLH127

Réf. BM	Réf. SILCA	UNIV.	TYPES DE MACHINES	MATÉRIEL	$\beta^\circ$	$\varnothing_1$ mm	$L_1$ mm	$\varnothing_2$ mm	Z	€
SLLH103	H103	FLLF1	QUATTROCODE / TRIAX-E	HSSV	90°	0,8	40	6	2	68,52
SLLH104	H104	FLLF1	QUATTROCODE / TRIAX-E	HSSV	90°	1,2	40	6	2	61,20
SLLH105	H105	FLLF1	QUATTROCODE / TRIAX-E	HSSV	90°	0,7	40	6	2	61,20
SLLH106	H106	FLLF1	QUATTROCODE / TRIAX-E	HSSV	90°	0,6	40	6	2	58,00
SLLH107	H107	FLLF1	QUATTROCODE / TRIAX-E	HSSV	90°	0,9	40	6	2	58,00
SLLH108	H108	FLLF82	QUATTROCODE / TRIAX-E	HSSV	82°	0,9	40	6	2	58,00
SLLH110	H110	FLLF13	QUATTROCODE / TRIAX-E	HSSV	100°	0,6	40	6	2	58,00
SLLH111	H111	FLLF95	QUATTROCODE / TRIAX-E	HSSV	96°	6,4x2,75*	40	6	2	58,00
SLLH112	H112	-	QUATTROCODE / TRIAX-E	HSSV	60°	1,5	40	6	2	58,00
SLLH113	H113	FLLF13	QUATTROCODE / TRIAX-E	HSSV	100°	0,76	40	6	2	58,00
SLLH115	H115	-	QUATTROCODE / TRIAX-E	HSSV	54°	4x0,86*	40	6	1	58,00
SLLH116	H116	FLLF1	QUATTROCODE / TRIAX-E	HSSV	90°	1	40	6	2	76,56
SLLH118	H118	-	QUATTROCODE / TRIAX-E	HSSV	120°	0,6	40	6	1	58,00
SLLH119	H119	FLLF82	QUATTROCODE / TRIAX-E	HSSV	85°	0,3	40	6	2	58,00
SLLH122	H122	FLLF1	QUATTROCODE / TRIAX-E	HSSV	90°	0,55	40	6	2	58,00
SLLH126	H126	FLLF85	QUATTROCODE / TRIAX-E	HSSV	80°	3,3*	48	6	2	86,57
SLLH127	H127	FLLF85	QUATTROCODE / TRIAX-E	HSSV	80°	2,1*	48	6	2	86,57
SLLH128	H128	FLLF1	QUATTROCODE / TRIAX-E	HSSV	90°	0,75	48	6	2	58,00

\*  $\varnothing_1 \times \varnothing_1$

**FRAISES POUR MACHINES DE REPRODUCTION DE CLÉS SILCA**

**FRAISES À RAINURER POUR CLÉS**

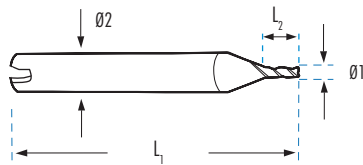

Ref. SLLH101



Ref. BM	Ref. SILCA	TYPES DE MACHINES	MATÉRIEL	Ø <sub>1</sub> mm	L <sub>1</sub> mm	Ø <sub>2</sub> mm	L <sub>2</sub> mm	Z	SLL
									€
SLLH101	H101	QUATTROCODE / TRIAX-E	HSSV	2,5	40	6	6	3	68,13
SLLH114	H114	QUATTROCODE / TRIAX-E	HSSV	2	40	6	6	3	58,00
SLLH117	H117	QUATTROCODE / TRIAX-E	HSSV	5	48	6	R1	4	70,37
SLLH129	H129	QUATTROCODE / TRIAX-E	HSSV	3	40	6	6	3	58,00
SLLH131	H131	QUATTROCODE / TRIAX-E	HSSV	6	40	6	5	3	76,56

**PALPEURS**

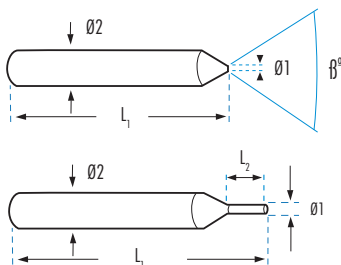

Ref. SLLT1



Ref. SLLT3

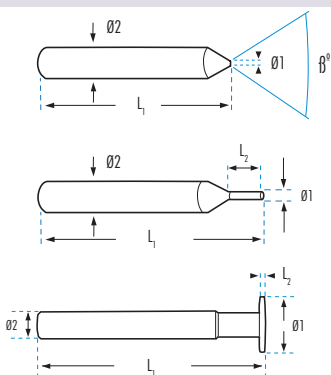

Ref. BM	Ref. SILCA	TYPES DE MACHINES	Ref. FRAISE	MATÉRIEL	β°	Ø <sub>1</sub> mm	L <sub>1</sub> mm	Ø <sub>2</sub> mm	L <sub>2</sub> mm	Ø <sub>T</sub> mm	SLL
											€
SLLT1	T1	MATRIX	F1	HSSV	90°	0,7	48	6	-	-	40,50
SLLT2	T2	MATRIX	F2	HSSV	88°	1,6	48	6	-	-	45,61
SLLT3	T3	MATRIX	F3	HSSV	-	1,5	48	6	3	-	45,61
SLLT4	T4	MATRIX	F4	HSSV	90°	0,4	48	6	-	-	45,61
SLLT5	T5	MATRIX	F5	HSSV	90°	0,9	48	6	-	-	45,61
SLLT6	T6	MATRIX	F6	HSSV	106°	1	48	6	15	-	45,61
SLLT7	T7	MATRIX	F7	HSSV	72°	0,8	48	6	2	-	45,61
SLLT8	T8	MATRIX	F8	HSSV	-	4	48	6	12	-	45,61
SLLT11	T11	MATRIX	F11	HSSV	-	2,5	48	6	6	-	45,61
SLLT12A	T12A	MATRIX	F12A	HSSV	100°	0,4	48	6	-	-	45,61
SLLT12B	T12B	MATRIX	F12B	HSSV	90°	2,8	48	6	-	-	45,61
SLLT13	T13	MATRIX	F13	HSSV	90°	0,77	48	6	-	-	45,61
SLLT14	T14	MATRIX	F14	HSSV	90°	0,9	48	6	-	-	45,61
SLLT15	T15	MATRIX	F15	HSSV	90°	0,8	48	6	-	-	45,61
SLLT19	T19	MATRIX	F19	HSSV	90°	2,2 x 0,6*	48	6	-	-	45,61
SLLT20	T20	MATRIX	F20	HSSV	90°	0,45	48	6	-	-	45,61
SLLT21	T21	MATRIX	F21	HSSV	85°	3,2 x 0,8*	48	6	-	-	45,61
SLLT22	T22	MATRIX	F22	HSSV	-	2,5	42	6	6	-	45,61
SLLT23	T23	MATRIX	F23	HSSV	90°	1,5	48	6	5	-	45,61

**FRAISES POUR MACHINES DE REPRODUCTION DE CLÉS SILCA**
**PALPEURS**

\*Réf. SLLT62W



Réf. SLLT1



Réf. SLLT3



Ref. BM	Ref. SILCA	TYPES DE MACHINES	Ref. FRAISE	MATÉRIEL	$\beta^\circ$	$\varnothing_1$ mm	$L_1$ mm	$\varnothing_2$ mm	$L_2$ mm	$\varnothing_T$ mm	SLL €
SLLT24	T24	MATRIX	F24	HSSV	100°	1,3	48	6	-	-	45,61
SLLT25	T25	MATRIX	F25	HSSV	90°	3,5 x 0,65*	48	6	-	-	45,61
SLLT26	T26	MATRIX	F26	HSSV	82°	0,8	48	6	-	-	45,61
SLLT27	T27	MATRIX	F27	HSSV	60°	1,28	48	6	-	-	51,49
SLLT28	T28	MATRIX	F28	HSSV	76°	0,76	48	6	-	-	45,61
SLLT29	T29	MATRIX	F29	HSSV	76°	1,9	48	6	-	-	45,61
SLLT30	T30	MATRIX	F30	HSSV	-	3	48	6	10	-	45,61
SLLT30-45	T30-45	MATRIX		HSSV	-	3	45	6	10	-	45,61
SLLT33	T33	MATRIX	F33	HSSV	48°	1,4	48	6	-	-	68,01
SLLT34	T34	MATRIX	F34	HSSV	50°	1,5	48	6	-	-	45,61
SLLT37	T37	MATRIX	F37	HSSV	90°	2,1	48	6	-	-	45,61
SLLT39	T39	MATRIX	F39	HSSV	90°	0,6	48	6	-	-	45,61
SLLT40	T40	MATRIX	F40	HSSV	108°	0,4	48	6	-	-	45,61
SLLT42	T42	MATRIX	F42	HSSV	100°	0,7	48	6	-	-	45,61
SLLT43	T43	MATRIX	F43	HSSV	90°	1	48	6	-	-	45,61
SLLT44	T44	MATRIX	F44	HSSV	-	2	48	6	8	-	45,61
SLLT44-45	T44-45	MATRIX		HSSV	-	2	45	6	8	-	45,61
SLLT46	T46	MATRIX	F46	HSSV	100°	0,65	48	6	-	-	45,61
SLLT49	T49	MATRIX	F49	HSSV	95°	0,8	48	6	-	-	45,61
SLLT50	T50	MATRIX	F50	HSSV	100°	0,5	48	6	-	-	45,61
SLLT52	T52	MATRIX	F52	HSSV	54°	0,86	48	6	6	2	45,61
SLLT54	T54	MATRIX	F54	HSSV	-	4	40	6	6,5	-	58,00
SLLT55	T55	MATRIX	F55	HSSV	100°	1	48	6	4	-	45,61
SLLT59	T59	MATRIX	F59	HSSV	90°	0,8	48	6	-	-	45,61
SLLT62W*	T62W	MATRIX	F62W	CARBURE	-	11,8	48	6	1	-	91,07
SLLT63	T63	MATRIX	F63	HSSV	78°	0,5	48	6	4	3	45,61
SLLT65	T65	MATRIX	F65	HSSV	90°	1,05	48	6	5	3	45,61
SLLT101	T101	MATRIX		HSSV	-	2,5	40	6	6	-	45,61
SLLT129	T129	MATRIX		HSSV	-	3	40	6	10	-	45,61
SLLU101	U101	QUATTROCODE		CARBURE	-	1,2	48	6	3	-	58,00
SLLU101/H	U101/H	QUATTROCODE / TRIAX-E		CARBURE	-	1,2	48	6	3	-	39,41
SLLU102/65	U102/65	QUATTROCODE / TRIAX-E		CARBURE	30°	0,2	48	6	9	2,6	61,95
SLLU102TT	U102TT	QUATTROCODE / TRIAX-E		CARBURE	30°	0,2	26	4	6	2	61,95
SLLU103	U103	QUATTROCODE / TRIAX-E		CARBURE	-	1	48	6	3	-	58,00
SLLU103/H	U103/H	QUATTROCODE / TRIAX-E		CARBURE	-	1	48	6	3	-	39,41
SLLU103-TT	U103-TT	QUATTROCODE / TRIAX-E		CARBURE	-	1	21	4	3	-	58,00
SLLU103-TT/H	U103-TT/H	QUATTROCODE / TRIAX-E		CARBURE	-	1	21	4	3	-	39,41
SLLU111	U111	SILCA VIPER		CARBURE	-	1	40	6	2,2	-	58,00
SLLU111/H	U111/H	SILCA VIPER		CARBURE	-	1	40	6	2,2	-	39,41
SLLB3304	B3304	KEYLINE BIANCHI 994 LASER		CARBURE	-	1	33	6	6	-	58,02
SLLB3310	B3310	KEYLINE BIANCHI 994 LASER		CARBURE	-	1	30	6	2,6	-	58,02
SLLB3310M2	B3310	KEYLINE BIANCHI 994 LASER		HSSV	-	1	30	6	2,6	-	42,98