

# CORONAS



**BLUE-MASTER<sup>®</sup>**  
by *celesa*

CUTTING TECHNOLOGIES

**GUÍA PARA LA SELECCIÓN DE CORONAS**
**CORONAS PARA METAL**

REFERENCIA	Tipo y Profundidad de corte	Recomendación y Aplicación Características y Gama	Pag.
CB	BI-METAL HSS 35 mm	<p>Gama de Ø14/250mm</p>	534
COB	BI-METAL HSSCo 8% 45 mm	<p>Gama de Ø14/152mm</p>	535
CBX100	BI-METAL HSS 100 mm	<p>Gama de Ø25/152mm</p>	538
COBX100	BI-METAL HSSCo 8% 100 mm	<p>Gama de Ø25/51 mm</p>	538
CBR	HSS 5 mm	<p>Gama de Ø8/100mm</p>	542
CBR..T	HSS-TiN 5 mm	<p>Gama de Ø8/100mm</p>	543
CBC	HSSCo Inox 10 mm	<p>Gama de Ø12/100mm</p>	544
CBCTL	HSSCo Inox TiAIN 10 mm	<p>Gama de Ø12/100mm</p>	545
CCF	HSS 2 mm	<p>Gama de Ø10/50mm</p>	546
CBMD	MD 35 mm	<p>Gama de Ø19/152mm</p>	547
CP	12 mm	<p>Gama de Ø15/35mm</p>	548

**CORONAS PARA METAL**

REFERENCIA	Tipo y Profundidad de corte	Recomendación y Aplicación Características y Gama	Pag.
CX CXL	MD 12 mm 25 mm	<p>Gama de Ø18/65mm</p>	549
X	MD 5 mm	<p>Gama de Ø14/120mm</p>	550
XT	MD 5 mm	<p>Gama de Ø16/150mm</p>	550
CXX	MD 50 mm	<p>Gama de Ø14/100mm</p>	552
C50X	MD 5 mm	<p>Gama de Ø14/100mm</p>	553
MBM	MD 50 mm	<p>Gama de Ø35/150mm</p>	554

**CORONAS PARA MÁQUINAS DE BASE ELECTROMAGNÉTICA**

REFERENCIA	Tipo y Profundidad de corte	Recomendación y Aplicación Características y Gama	Pag.
250R 500R	HSS 30 mm 50 mm	<p>Gama de Ø12/50mm</p>	558
250C 500C 750C 1000C	HSS 30 mm 50 mm 75 mm 100 mm	<p>Gama de Ø12/100mm</p>	559 560
1500C 2000C	HSS 150 mm 200 mm	<p>Gama de Ø22/50mm - Ø26/50mm</p>	562

**GUÍA PARA LA SELECCIÓN DE CORONAS**

**CORONAS PARA MÁQUINAS DE BASE ELECTROMAGNÉTICA**

REFERENCIA	Tipo y Profundidad de corte	Recomendación y Aplicación Características y Gama	Pag.
250T 500T	HSSCo 30 mm 50 mm	HSSCo 8% 2 x 90° WELDON 110 Kg/mm² INOX Al Gama de Ø12/60mm	560
350A 500A	MD 35 mm 50 mm	MD INOX Al Cu-Ni-La FUNDICIÓN Gama de Ø14/52mm - Ø14/70mm	563
750A 1000A	MD 75mm 100 mm	MD INOX Al Cu-Ni-La FUNDICIÓN Gama de Ø16/70mm	564
MB250AT MB500AT	HSSCo 25/50 mm	HSSCo 8% 2 x 90° WELDON TiAlN Gama de Ø16/32mm	565
MB350ST	MD 35 m	MD INOX Al Cu-Ni-La FUNDICIÓN Gama de Ø16/32mm	565

**CORONAS PARA CONSTRUCCIÓN**

REFERENCIA	Tipo y Profundidad de corte	Recomendación y Aplicación Características y Gama	Pag.
600W	MD 80 mm	SDS Plus MD Gama de Ø25/100mm	574
CW	MD 95 mm	SDS Plus SDS Max MD Gama de Ø25/200mm	575
HA	MD 54 mm	MD SDS Plus Gama de Ø25/112mm	576
MD	MD 60 mm	MD SDS Plus Gama de 22/120mm	577

**CORONAS PARA CONSTRUCCIÓN**

REFERENCIA	Tipo y Profundidad de corte	Recomendación y Aplicación Características y Gama	Pag.
MH	MD 100 mm	MD SDS Max Gama de Ø25/150mm	578
HAR	MD 80 mm	MD SDS Max Gama de Ø45/150mm	579
CDE	PORCELÁNICO 40 mm	PORCELÁNICO PVC Gama de Ø12/120mm	580
CMAD	PORCELÁNICO 40 mm	PORCELÁNICO PVC Gama de Ø20/50mm	580
CHH	DIAMANTE 300-450 mm	DIAMANTE Gama de Ø25/83mm	581
CSE	PORCELÁNICO 35 mm	PORCELÁNICO PVC M14x2 Gama de Ø25/83mm	582
MG	CARBURO 30 mm	Tungsteno FUNDICIÓN Gama de Ø16/114mm	584
CM	MADERA 60 mm Ø22/125	MD PVC Gama de Ø22/125mm	585
TB CL		CORONA CORTACÍRCULOS Ø200/220/285/410 mm PLADUR ESCAVOLA	586
CDH	150 mm	DIAMANTE PVC Gama de Ø25/83mm	589

**CORONA PERFORADORA BI-METAL ACERO RÁPIDO HSS 4/6 DIENTE VARIABLE**

Ref. CB

**HSS  
M3**
**4/6**

**Al**

**Cu-Ni-La**
**FUNDICIÓN**

**PVC**
**35 mm  
CAPACIDAD  
DE CORTE**

 Dimensiones burbuja ext:  
 165 x 105 mm

**CORONA Ref. CB PRESENTADA EN CAJA Y BLISTER**

Ø mm	Ø Pulgadas	Caja		Blister	
		Ref.	€	Ref.	€
14	9/16	CB14	11,99	CB14B	11,99
16	5/8	CB16	11,99	CB16B	11,99
17	11/16	CB17	12,39	CB17B	12,39
19	3/4	CB19	12,39	CB19B	12,39
20	-	CB20	12,39	CB20B	12,39
21	13/16	CB21	12,39	CB21B	12,39
22	7/8	CB22	12,81	CB22B	12,81
24	15/16	CB24	13,15	CB24B	13,15
25	1"	CB25	13,50	CB25B	13,50
27	1.1/16	CB27	13,91	CB27B	13,91
29	1.1/8	CB29	14,67	CB29B	14,67
30	1.3/16	CB30	15,03	CB30B	15,03
32	1.1/4	CB32	15,40	CB32B	15,40
33	1.5/16	CB33	15,56	CB33B	15,56
35	1.3/8	CB35	15,91	CB35B	15,91
37	1.7/16	CB37	15,91	CB37B	15,91
38	1.1/2	CB38	16,37	CB38B	16,37
40	1.9/16	CB40	17,09	CB40B	17,09
41	1.5/8	CB41	17,09	CB41B	17,09
43	1.11/16	CB43	18,09	CB43B	18,09
44	1.3/4	CB44	19,13	CB44B	19,13
45	-	CB45	19,13	CB45B	19,13
46	1.13/16	CB46	19,22	CB46B	19,22
48	1.7/8	CB48	19,73	CB48B	19,73
50	-	CB50	19,73	CB50B	19,73
51	2"	CB51	19,73	CB51B	19,73
52	2.1/16	CB52	20,62	CB52B	20,62
54	2.1/8	CB54	20,69	CB54B	20,69
55	-	CB55	20,69	CB55B	20,69
57	2.1/4	CB57	21,77	CB57B	21,77
59	2.5/16	CB59	22,67	CB59B	22,67
60	2.3/8	CB60	22,71	CB60B	22,71

Ø mm	Ø Pulgadas	Caja		Blister	
		Ref.	€	Ref.	€
64	2.1/2	CB64	23,07	CB64B	23,07
65	2.9/16	CB65	25,81	CB65B	25,81
67	2.5/8	CB67	25,81	CB67B	25,81
68	-	CB68	25,81	CB68B	25,81
70	2.3/4	CB70	26,34	CB70B	26,34
73	2.7/8	CB73	26,83	CB73B	26,83
75	-	CB75	27,52	CB75B	27,52
76	3"	CB76	27,52	CB76B	27,52
79	3.1/8	CB79	28,12	CB79B	28,12
83	3.1/4	CB83	28,12	CB83B	28,12
86	3.3/8	CB86	28,22		
89	3.1/2	CB89	28,33		
92	3.5/8	CB92	31,26		
95	3.3/4	CB95	33,65		
98	3.7/8	CB98	34,84		
100	-	CB100	36,69		
102	4"	CB102	36,69		
104	4.1/8	CB104	40,55		
108	4.1/4	CB108	44,80		
111	4.3/8	CB111	49,15		
114	4.1/2	CB114	56,10		
121	4.3/4	CB121	62,32		
127	5"	CB127	69,06		
140	5.1/2	CB140	82,34		
146	5.3/4	CB146	87,81		
152	6"	CB152	93,30		
160	-	CB160	128,41		
168	-	CB168	141,11		
177	-	CB177	143,73		
210	-	CB210	151,57		
225	-	CB225	200,58		
250	-	CB250	244,74		

Las Coronas de Ø14 hasta Ø30 no incluyen orificios de arrastre para husillos con pasadores.  
 Consultar condiciones de corte en la página 556.

**CORONA PERFORADORA BI-METAL ACERO RÁPIDO HSSCo 8% 4/6 DIENTE VARIABLE**

Ref. COB

HSSCo 8%
4/6
INOX
FUNDICIÓN
Cu-Ni-La

- Mayor duración afilado y corte.
- Cortes más rápidos y precisos.
- Menor vibración y desgaste.
- M42. Mayor dureza y rendimiento.

**45 mm**  
CAPACIDAD DE CORTE



Dimensiones burbuja ext:  
165 x 105 mm

**CORONA Ref. COB PRESENTADA EN CAJA Y BLISTER**

		COB			
Ø mm	Ø Pulgadas	Caja		Blister	
		Ref.	€	Ref.	€
14	9/16	COB14	12,83	COB14B	12,83
16	5/8	COB16	12,83	COB16B	12,83
17	11/16	COB17	13,25	COB17B	13,25
19	3/4	COB19	13,25	COB19B	13,25
20	-	COB20	13,25	COB20B	13,25
21	13/16	COB21	13,25	COB21B	13,25
22	7/8	COB22	13,58	COB22B	13,58
24	15/16	COB24	13,62	COB24B	13,62
25	1"	COB25	14,25	COB25B	14,25
27	1.1/16	COB27	14,86	COB27B	14,86
29	1.1/8	COB29	15,10	COB29B	15,10
30	1.3/16	COB30	15,31	COB30B	15,31
32	1.1/4	COB32	15,70	COB32B	15,70
33	1.5/16	COB33	15,88	COB33B	15,88
35	1.3/8	COB35	16,21	COB35B	16,21
37	1.7/16	COB37	16,21	COB37B	16,21
38	1.1/2	COB38	16,69	COB38B	16,69
40	1.9/16	COB40	17,41	COB40B	17,41
41	1.5/8	COB41	17,41	COB41B	17,41
43	1.11/16	COB43	18,45	COB43B	18,45
44	1.3/4	COB44	19,77	COB44B	19,77
45	-	COB45	19,77	COB45B	19,77
46	1.13/16	COB46	19,84	COB46B	19,84
48	1.7/8	COB48	20,11	COB48B	20,11
50	-	COB50	20,11	COB50B	20,11
51	2"	COB51	20,11	COB51B	20,11
52	2.1/16	COB52	22,06	COB52B	22,06
54	2.1/8	COB54	22,13	COB54B	22,13
55	-	COB55	22,13	COB55B	22,13
57	2.1/4	COB57	23,19	COB57B	23,19
59	2.5/16	COB59	23,38	COB59B	23,38
60	2.3/8	COB60	23,38	COB60B	23,38

		COB			
Ø mm	Ø Pulgadas	Caja		Blister	
		Ref.	€	Ref.	€
64	2.1/2	COB64	24,69	COB64B	24,69
65	2.9/16	COB65	26,31	COB65B	26,31
67	2.5/8	COB67	26,31	COB67B	26,31
68	-	COB68	26,31	COB68B	26,31
70	2.3/4	COB70	26,85	COB70B	26,85
73	2.7/8	COB73	27,35	COB73B	27,35
75	-	COB75	28,06	COB75B	28,06
76	3"	COB76	28,06	COB76B	28,06
79	3.1/8	COB79	28,67	COB79B	28,67
83	3.1/4	COB83	28,67	COB83B	28,67
86	3.3/8	COB86	28,76		
89	3.1/2	COB89	28,88		
92	3.5/8	COB92	31,85		
95	3.3/4	COB95	36,01		
98	3.7/8	COB98	37,29		
100	-	COB100	39,26		
102	4"	COB102	39,26		
104	4.1/8	COB104	43,38		
108	4.1/4	COB108	47,94		
111	4.3/8	COB111	52,60		
114	4.1/2	COB114	61,70		
121	4.3/4	COB121	68,56		
127	5"	COB127	75,97		
140	5.1/2	COB140	90,57		
146	5.3/4	COB146	96,61		
152	6"	COB152	97,50		

**R.P.M. RECOMENDADAS**

RANGO Ø mm	R.P.M
14-25	600
27-45	350
46-60	250
64-83	150
86-102	120
104-121	90
127-152	60

Las Coronas de Ø14 hasta Ø30 no incluyen orificios de arrastre para husillos con pasadores.  
Consultar condiciones de corte en la página 556.

## HUSILLOS Y ACCESORIOS PARA CORONAS BIMETÁLICAS

### HUSILLOS CON O SIN MUELLE EXPULSOR PRESENTADOS EN CAJA Y BLISTER



Ref. B5514



Ref. B5518

 → Ref. B5519  
 El más habitual

Ref. B5520



Ref. B5545

 → Ref. B5546  
 El más habitual

Ref. B5547\*



Ref. B5556SDS



Ref. B5547M



#### SIN MUELLE EXPULSOR

#### CON MUELLE EXPULSOR

Tipo de Mango	Capacidad Ø mm	Caja		Blister		Caja		Blister	
		Ref.	€	Ref.	€	Ref.	€	Ref.	€
Ø 6,35 mm	14 - 30	B5514	12,61	B5514S	13,45	B5514M	13,93	5514-BME	13,96
Ø 11,0 mm	14 - 30	B5518	16,59	B5518S	17,69	B5518M	17,90	5518-BME	17,90
Ø 9,5 mm	14 - 30	B5519	16,98	B5519S	18,47	B5519M	18,26	5519-BME	19,86
Ø 11,0 mm	32 - 38	B5520	19,90	B5520S	19,90	B5520M	21,20		
Ø 11,0 mm	32 - 250	B5545	26,92	B5545S	26,92	B5545M	28,21		
Ø 9,5 mm	32 - 250	B5546	26,92	B5546S	28,72	B5546M	28,21	5546-BME	30,10
Ø 11,0 mm	32 - 250	B5547*	28,11	B5547S	30,73	B5547M	29,44	5547-BME	32,19
Ø 16,0 mm	32 - 250	B5573	29,33			B5573M	30,64		
SDS-PLUS	14 - 30	B5529SDS	22,55			B5529SDSM	23,25		
SDS-PLUS	32 - 250	B5556SDS	41,76			B5556SDSM	42,67		

#### MUELLE EXPULSOR

 B8530  
 0,96 €

\* Husillo rígido de alto rendimiento

### BROCAS GUÍA

#### HSS



Ref. B8534 (La más habitual)



Ref. B8535



Ref. B8536



Ref. B8537



Ref. B8538



Ø mm	Lt mm	CHAVETEROS	UNIDAD EMBALAJE	HUSILLOS CORRESPONDIENTES	Caja		Blister	
					Ref.	€	Ref.	€
6,35	83	2	10	5514-5518-5519-5520-5545-5546 5573-5529SDS -5556SDS -5547	B8534	6,30	B8534S	8,31
6,35	107	3	10	5514-5518-5519-5520-5545-5546 5573-5529SDS -5556SDS -5547	B8535	6,30	B8535S	8,31
6,35	87	1	10	5514-5518-5520-5573-5545	B8536	6,30	B8536S	8,31
6,35	82	1	10	Coronas Mastergrit	B8537	5,41	B8537S	6,75
6,35	97	1	10	Coronas Mastergrit	B8538	5,41	B8538S	6,75

**ACCESORIOS PARA CORONAS BIMETÁLICAS**

**ALARGADOR DE HUSILLOS DE 300 mm**



Válido para Husillos:  
Ref. 5519-5546  
Mango hexagonal 9,5mm

B5500  
24,61 €

**ADAPTADOR DE HUSILLOS**



Este adaptador roscado permite a los husillos 5514, 5518 y 5519 utilizar coronas superiores a 30 mm bajo condiciones de corte favorables

B5511  
8,55 €

**TORNILLOS DE REPUESTO (SUJECCIÓN DE LA BROCA AL HUSILLO)**



Tornillo para husillos:  
Ref. 5514 - 5518 - 5519 - 5520

BSS1  
2,24 €



Tornillo para husillos:  
Ref. 5545 - 5546 - 5573

BSS2  
2,24 €

**CONJUNTO DE CORONA Y ARANDELA AVELLANADORA PARA PLADUR**

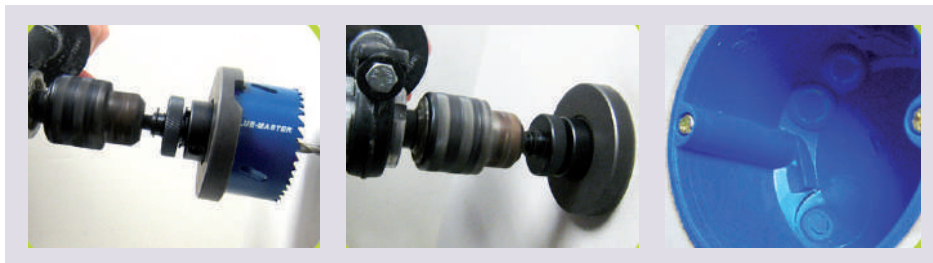

**Conjunto 1 Ø67**

Ref. CPL67

Contenido:

- 1 Corona Bimetálica CB67 : Ø 67 mm
- 1 Husillo Ref. B5547
- 1 Arandela avellanadora Pladur Ref. CPL

89,47 €



**Conjunto 2 Ø68**

Ref. CPL68

Contenido:

- 1 Corona Bimetálica CB68 : Ø 68 mm
- 1 Husillo Ref. B5547
- 1 Arandela avellanadora Pladur Ref. CPL

89,47 €

**COMPONENTES**

	DESCRIPCIÓN	€
CPL	Arandela avellanadora para Pladur	58,65
B5547	Husillo rígido para coronas Ø 32-250 mm	28,11
CB67	Corona Bimetálica Ø 67 mm	25,81
CB68	Corona Bimetálica Ø 68 mm	25,81

**CORONA PERFORADORA BI-METAL EXTRALARGA ACERO RÁPIDO HSS PARA CERRAJEROS**

Coronas

Rosa

Ref. CBX100

**HSS**  
**M3**
**4/6**

**Al**

**Cu-Ni-La**
**FUNDICIÓN**

**PVC**
**100 mm**  
**CAPACIDAD**  
**DE CORTE**

CBX100		
	Ø mm	€
CB25X100	25	59,80
CB27X100	27	65,84
CB29X100	29	69,46
CB30X100	30	71,18
CB32X100	32	72,93
CB33X100	33	73,76
CB35X100	35	70,42
CB38X100	38	77,54
CB40X100	40	75,60

CBX100		
	Ø mm	€
CB41X100	41	80,89
CB43X100	43	85,67
CB44X100	44	86,22
CB45X100	45	86,22
CB46X100	46	86,74
CB48X100	48	86,74
CB50X100	50	87,56
CB51X100	51	87,56
CB52X100	52	95,16
CB54X100	54	95,56
CB55X100	55	95,56
CB57X100	57	100,56
CB59X100	59	104,63
CB60X100	60	104,90
CB64X100	64	106,50
CB65X100	65	119,18
CB67X100	67	119,18
CB68X100	68	119,18
CB70X100	70	121,66

CBX100		
	Ø mm	€
CB73X100	73	123,91
CB75X100	75	127,09
CB79X100	79	129,90
CB83X100	83	129,90
CB86X100	86	130,33
CB89X100	89	130,84
CB92X100	92	144,30
CB95X100	95	152,46
CB98X100	98	157,89
CB100X100	100	166,26
CB102X100	102	166,26
CB104X100	104	183,78
CB108X100	108	202,99
CB111X100	111	222,76
CB114X100	114	254,19
CB127X100	127	312,92
CB140X100	140	373,11
CB146X100	146	397,93
CB152X100	152	422,80

Las Coronas de Ø14 hasta Ø30 no incluyen orificios de arrastre para husillos con pasadores.

**CORONA PERFORADORA BI-METAL ACERO RÁPIDO HSSCo 4/6 DIENTE VARIABLE**

Ref. COBX100

**HSSCo**  
**8%**
**4/6**

**FUNDICIÓN**

**Cu-Ni-La**

- Mayor duración afilado y corte.
- Cortes más rápidos y precisos.
- Menor vibración y desgaste.
- M42. Mayor dureza y rendimiento.

**100 mm**  
**CAPACIDAD**  
**DE CORTE**

COBX100		
	Ø mm	€
COB25X100	25	78,98
COB35X100	35	93,01
COB40X100	40	99,84
COB45X100	45	111,75
COB50X100	50	112,42
COB51X100	51	112,42

**HUSILLOS PARA CORONAS SERIE LARGA**

**BROCA GUÍA**

DESCRIPCIÓN	RANGO mm	€	Ø mm	Lt mm	HUSILLOS CORRESPONDIENTES	€
B5516	14 - 30	28,62	6,35	155	B5516 / B5548	17,23
B5548	32-250	43,45				



**EXPOSITORES DE CORONAS BI-METÁLICAS**



Ref. CB

<b>HSS M3</b>	<b>4/6</b>		<b>Al</b>		<b>FUNDICIÓN</b>	<b>PVC</b>	
---------------	------------	--	-----------	--	------------------	------------	--

HUSILLOS EXPOSITOR DE CORONAS BLUEMASTER

B5519	CB16	CB19	CB20	CB22	CB25	CB27	CB30
Ø 14-30	Ø 16	Ø 19	Ø 20	Ø 22	Ø 25	Ø 27	Ø 30
5	3	3	3	3	3	3	3
B5546	CB32	CB35	CB40	CB48	CB50	CB60	CB68
Ø32-250	Ø 32	Ø 35	Ø 40	Ø 48	Ø 50	Ø 60	Ø 68
4	3	3	2	2	2	2	2

Ref. CBEXP1      530 mm  
 772,71 €      ↑ → 885 mm



Ref. COB

<b>HSSCo 8%</b>	<b>4/6</b>		<b>INOX</b>		<b>FUNDICIÓN</b>
-----------------	------------	--	-------------	--	------------------

HUSILLOS EXPOSITOR DE CORONAS HSS-CO 8% BLUEMASTER

B5519	COB16	COB19	COB20	COB22	COB25	COB27	COB30
Ø 14-30	Ø 16	Ø 19	Ø 20	Ø 22	Ø 25	Ø 27	Ø 30
5	3	3	3	3	3	3	3
B5546	COB32	COB35	COB40	COB48	COB51	COB60	COB68
Ø32-250	Ø 32	Ø 35	Ø 40	Ø 48	Ø 51	Ø 60	Ø 68
4	3	3	2	2	2	2	2

Ref. COBEXP1      530 mm  
 794,96 €      ↑ → 885 mm

**MALETINES DE CORONAS PERFORADORAS BI-METÁLICAS HSS**
**HSS  
M3**
**4/6**

**Al**

**Cu-Ni-La**
**FUNDICIÓN**

**PVC**
**35 mm  
CAPACIDAD  
DE CORTE**

Ref. CB

**MALETÍN DE CORONAS PARA ELECTRICISTAS**
**9  
Piezas**

**CB9571** 6 Coronas CB: **Ø 22 - 35 - 51 - 60 - 68 - 73 mm**
**CB9574** 6 Coronas CB: **Ø 22 - 35 - 50 - 60 - 68 - 73 mm**

Contenido

1 Husillo Ref. 5519  $\square$  9,5 Capacidad 14-301 Husillo Ref. 5546  $\square$  9,5 Capacidad 32-250

1 Adaptador husillo Ref. 5511

**137,35 €**
**MALETÍN DE CORONAS PARA FONTANEROS**
**10  
Piezas**
**CB9570** 7 Coronas CB: **Ø 20 - 25 - 32 - 40 - 44 - 60 - 68 mm**
**CB9573** 7 Coronas CB: **Ø 20 - 25 - 30 - 40 - 44 - 60 - 68 mm**
**CB9575** 7 Coronas CB: **Ø 19 - 25 - 32 - 40 - 44 - 60 - 68 mm**

Contenido

1 Husillo Ref. 5519  $\square$  9,5 Capacidad 14-301 Husillo Ref. 5546  $\square$  9,5 Capacidad 32-250

1 Adaptador husillo Ref. 5511

**131,94 €**

**MALETÍN PARA MANTENIMIENTO INDUSTRIAL**
**13  
Piezas**

**CB9572** 10 Coronas CB: **20 - 22 - 25 - 32 - 35 - 40 - 44 - 60 - 68 - 76 mm**

Contenido

1 Husillo Ref. 5519  $\square$  9,5 Capacidad 14-301 Husillo Ref. 5546  $\square$  9,5 Capacidad 32-250

1 Adaptador husillo Ref. 5511

**166,29 €**

**MALETINES DE CORONAS PERFORADORAS BI-METÁLICAS HSSCo 8%**

**HSSCo**  
8%

**4/6**

**INOX**



**FUNDICIÓN**

**Cu-Ni-La**

- Mayor duración afilado y corte.
- Cortes más rápidos y precisos.
- Menor vibración y desgaste.
- M42. Mayor dureza y rendimiento.

**45 mm**  
**CAPACIDAD**  
**DE CORTE**



Ref. COB

**MALETÍN DE CORONAS PARA ELECTRICISTAS**

**9**  
**Piezas**



COB9571 6 Coronas COB: Ø 22 - 35 - 51 - 60 - 68 - 73 mm

COB9574 6 Coronas COB: Ø 22 - 35 - 50 - 60 - 68 - 73 mm

Contenido

- 1 Husillo Ref. 5519  $\square$  9,5 Capacidad 14-30
- 1 Husillo Ref. 5546  $\square$  9,5 Capacidad 32-250
- 1 Adaptador husillo Ref. 5511

151,09 €

**MALETÍN DE CORONAS PARA FONTANEROS**

**10**  
**Piezas**

COB9570 7 Coronas COB: Ø 20 - 25 - 32 - 40 - 44 - 60 - 68 mm

COB9573 7 Coronas COB: Ø 20 - 25 - 30 - 40 - 44 - 60 - 68 mm

COB9575 7 Coronas COB: Ø 19 - 25 - 32 - 40 - 44 - 60 - 68 mm

Contenido

- 1 Husillo Ref. 5519  $\square$  9,5 Capacidad 14-30
- 1 Husillo Ref. 5546  $\square$  9,5 Capacidad 32-250
- 1 Adaptador husillo Ref. 5511

145,13 €



**MALETÍN PARA MANTENIMIENTO INDUSTRIAL**

**13**  
**Piezas**



COB9572 10 Coronas COB: 20 - 22 - 25 - 32 - 35 - 40 - 44 - 60 - 68 - 76 mm

Contenido

- 1 Husillo Ref. 5519  $\square$  9,5 Capacidad 14-30
- 1 Husillo Ref. 5546  $\square$  9,5 Capacidad 32-250
- 1 Adaptador husillo Ref. 5511

182,91 €

**CORONA REAFILABLE HSS PARA METALES**
**HSS**

Ref. CBR

**Al**

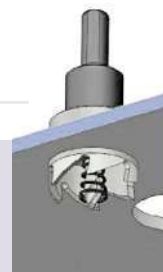
**Cu - Ni - La**
**FUNDICIÓN**
**5 mm  
CAPACIDAD  
DE CORTE**

Apriete las garras del portabrocas sobre los tres planos de arrastre del husillo para evitar que patine al taladrar

	Ø mm	€
CBR010	10	21,31
CBR011	11	21,31
CBR012	12	21,64
CBR013	13	21,68
CBR014	14	21,68
CBR015	15	21,68
CBR016	16	21,68
CBR017	17	23,21
CBR018	18	24,98
CBR019	19	26,36
CBR020	20	27,78
CBR021	21	27,87
CBR022	22	29,21
CBR023	23	30,75
CBR024	24	32,36
CBR025	25	33,75
CBR026	26	35,16
CBR027	27	36,60
CBR028	28	38,58
CBR029	29	40,05
CBR030	30	40,10
CBR031	31	42,53
CBR032	32	43,00
CBR033	33	44,43
CBR034	34	45,70
CBR035	35	45,77
CBR036	36	48,56
CBR037	37	50,73
CBR038	38	50,90
CBR039	39	52,47

	Ø mm	€
CBR040	40	53,91
CBR041	41	56,51
CBR042	42	56,76
CBR043	43	59,56
CBR044	44	60,69
CBR045	45	61,01
CBR046	46	63,58
CBR047	47	63,80
CBR048	48	64,03
CBR049	49	66,06
CBR050	50	67,14
CBR051	51	82,27
CBR052	52	82,27
CBR053	53	82,27
CBR054	54	83,09
CBR055	55	83,09
CBR056	56	97,99
CBR057	57	97,99
CBR058	58	97,99
CBR059	59	97,99
CBR060	60	97,99
CBR061	61	114,45
CBR062	62	114,45
CBR063	63	114,45
CBR064	64	114,45
CBR065	65	114,45
CBR066	66	136,15
CBR067	67	136,15
CBR068	68	136,15
CBR069	69	136,15

	Ø mm	€
CBR070	70	136,15
CBR071	71	143,13
CBR072	72	143,13
CBR073	73	143,13
CBR074	74	143,13
CBR075	75	143,13
CBR076	76	162,75
CBR077	77	162,75
CBR078	78	162,75
CBR079	79	162,75
CBR080	80	162,75
CBR081	81	185,51
CBR082	82	185,51
CBR083	83	185,51
CBR084	84	185,51
CBR085	85	185,51
CBR086	86	194,61
CBR087	87	194,95
CBR088	88	194,95
CBR089	89	194,95
CBR090	90	194,95
CBR091	91	214,16
CBR092	92	216,50
CBR093	93	216,50
CBR094	94	216,50
CBR095	95	216,50
CBR096	96	225,91
CBR097	97	225,91
CBR098	98	225,91
CBR099	99	225,91
CBR100	100	226,27

Estas coronas se suministran siempre, sin excepción, con husillo de mango cilíndrico y broca guía.



Ref. AT12



Ref. CM12

**HUSILLOS PARA CORONAS REAFILABLES CON Y SIN TiN**

DESCRIPCIÓN	RANGO Ø mm	€
AT09	Mango Ø7mm Triangular rosca M9x1,25+broca Ø5mm	10 - 13 17,22
AT10	Mango Ø8mm Triangular rosca M10x1,25+broca Ø5mm	14 - 22 17,22
AT12	Mango Ø9mm Triangular rosca M12x1,25+broca Ø6mm	23 - 40 19,29
AT16	Mango Ø10mm Triangular rosca M16x1,25+broca Ø6mm	41 - 60 24,50
AT20	Mango Ø12mm Triangular rosca M20x1,25+broca Ø8mm	61 - 90 28,06
AT28	Mango Ø13mm Triangular rosca M28x2,00+Broca Ø 8 mm	91 - 100 37,86
CM09	Cono Morse 2 - rosca M09x1,25 + broca Ø5mm	10 - 13 44,31
CM10	Cono Morse 2 - rosca M10x1,25 + broca Ø5mm	14 - 22 44,31
CM12	Cono Morse 2 - rosca M12x1,25 + broca Ø6mm	23 - 40 45,29
CM16	Cono Morse 2 - rosca M16x1,25 + broca Ø6mm	41 - 60 45,29
CM20	Cono Morse 3 - rosca M20x1,25 + broca Ø8mm	61 - 90 65,71
CM28	Cono Morse 4 - rosca M28x2,00 + broca Ø8mm	91 - 100 108,98

**BROCAS GUÍA**

DESCRIPCIÓN	RANGO Ø mm	€
B5	HSS Ø 5 mm	10 - 22 6,76
B6	HSS Ø 6 mm	23 - 60 7,78
B8	HSS Ø 8 mm	61 - 100 8,61
B6TiN	HSS + TiN Ø 6 mm	23 - 60 11,97
B8TiN	HSS + TiN Ø 8 mm	61 - 100 14,02



**CORONA REAFILABLE HSS+ TIN PARA METALES**

**HSS**

**TiN**

Ref. CBR..T



**Al**



**Cu-Ni-La**

**FUNDICIÓN**

**5 mm  
CAPACIDAD  
DE CORTE**

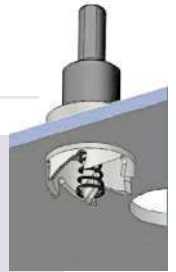

Coronas

Rosa



CBR..T		
	Ø mm	€
CBR010T	10	33,60
CBR011T	11	33,95
CBR012T	12	33,95
CBR013T	13	35,72
CBR014T	14	35,72
CBR015T	15	35,72
CBR016T	16	37,87
CBR017T	17	41,44
CBR018T	18	42,88
CBR019T	19	47,18
CBR020T	20	49,31
CBR021T	21	51,46
CBR022T	22	53,58
CBR023T	23	56,09
CBR024T	24	58,97
CBR025T	25	60,76
CBR026T	26	68,24
CBR027T	27	69,68
CBR028T	28	71,46
CBR029T	29	72,89
CBR030T	30	74,31
CBR031T	31	76,47
CBR032T	32	77,90
CBR033T	33	80,04
CBR034T	34	82,56
CBR035T	35	85,39
CBR036T	36	87,54
CBR037T	37	90,04
CBR038T	38	92,16

CBR..T		
	Ø mm	€
CBR039T	39	95,03
CBR040T	40	97,56
CBR041T	41	99,69
CBR042T	42	102,18
CBR043T	43	104,32
CBR044T	44	107,19
CBR045T	45	109,69
CBR046T	46	111,86
CBR047T	47	114,35
CBR048T	48	119,00
CBR049T	49	119,36
CBR050T	50	121,47
CBR051T	51	146,26
CBR052T	52	149,22
CBR053T	53	151,95
CBR054T	54	154,79
CBR055T	55	157,93
CBR056T	56	160,58
CBR057T	57	163,41
CBR058T	58	166,75
CBR059T	59	169,24
CBR060T	60	172,23
CBR061T	61	202,89
CBR062T	62	206,38
CBR063T	63	209,61
CBR064T	64	212,82
CBR065T	65	216,53
CBR066T	66	219,54
CBR067T	67	222,75
CBR068T	68	226,22
CBR069T	69	229,46

CBR..T		
	Ø mm	€
CBR070T	70	235,82
CBR071T	71	236,57
CBR072T	72	240,09
CBR073T	73	243,54
CBR074T	74	246,87
CBR075T	75	250,22
CBR076T	76	253,84
CBR077T	77	257,20
CBR078T	78	260,53
CBR079T	79	264,16
CBR080T	80	270,88
CBR081T	81	270,88
CBR082T	82	274,34
CBR083T	83	277,83
CBR084T	84	281,19
CBR085T	85	284,68
CBR086T	86	288,16
CBR087T	87	291,52
CBR088T	88	294,87
CBR089T	89	298,34
CBR090T	90	303,00
CBR091T	91	312,79
CBR092T	92	316,35
CBR093T	93	319,92
CBR094T	94	323,35
CBR095T	95	326,93
CBR096T	96	330,52
CBR097T	97	333,91
CBR098T	98	337,37
CBR099T	99	341,08
CBR100T	100	346,58

Estas coronas se suministran siempre, sin excepción, con husillo de mango cilíndrico y broca guía.

**EXPOSITOR CORONAS REAFILABLES**

E41P

Contenido:  
41 Coronas Ref. CBR  
Ø 10 - Ø 50 mm

1.694,87 €



**CORONA REAFILABLE HSSCo PARA METALES (ESPECIAL INOX)**
**HSSCo**
**INOX**

Ref. CBC

**Al**

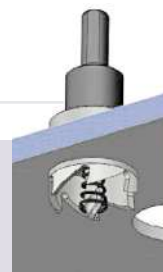
**Cu-Ni-La**
**FUNDICIÓN**
**10 mm**  
**CAPACIDAD**  
**DE CORTE**

 Afilado especial con  
 Rompevirutas

	CBC	
	Ø mm	€
CBC012	12	35,68
CBC013	13	35,68
CBC014	14	35,68
CBC015	15	36,67
CBC016	16	37,46
CBC017	17	38,05
CBC018	18	39,05
CBC019	19	40,85
CBC020	20	42,65
CBC021	21	44,82
CBC022	22	47,40
CBC023	23	49,02
CBC024	24	50,61
CBC025	25	52,61
CBC026	26	54,60
CBC027	27	56,99
CBC028	28	58,78
CBC029	29	60,77
CBC030	30	62,76
CBC031	31	64,35
CBC032	32	66,56
CBC033	33	68,54
CBC034	34	70,72
CBC035	35	73,12
CBC036	36	74,71
CBC037	37	76,91
CBC038	38	79,50
CBC039	39	84,46
CBC040	40	85,67
CBC041	41	85,48

	CBC	
	Ø mm	€
CBC042	42	87,43
CBC043	43	89,37
CBC044	44	90,94
CBC045	45	93,49
CBC046	46	95,04
CBC047	47	97,39
CBC048	48	99,16
CBC049	49	101,08
CBC050	50	102,84
CBC051	51	144,78
CBC052	52	148,19
CBC053	53	150,26
CBC054	54	153,10
CBC055	55	156,88
CBC056	56	159,53
CBC057	57	162,18
CBC058	58	164,82
CBC059	59	167,86
CBC060	60	170,31
CBC061	61	204,15
CBC062	62	207,55
CBC063	63	210,01
CBC064	64	213,98
CBC065	65	217,19
CBC066	66	228,73
CBC067	67	231,45
CBC068	68	234,79
CBC069	69	237,11
CBC070	70	240,64
CBC071	71	242,56

	CBC	
	Ø mm	€
CBC072	72	246,09
CBC073	73	249,40
CBC074	74	252,73
CBC075	75	256,23
CBC076	76	260,15
CBC077	77	262,88
CBC078	78	266,20
CBC079	79	269,71
CBC080	80	273,60
CBC081	81	276,35
CBC082	82	279,85
CBC083	83	283,17
CBC084	84	286,48
CBC085	85	290,01
CBC086	86	293,32
CBC087	87	296,62
CBC088	88	300,15
CBC089	89	303,26
CBC090	90	306,78
CBC091	91	310,30
CBC092	92	313,42
CBC093	93	316,92
CBC094	94	320,45
CBC095	95	323,56
CBC096	96	326,89
CBC097	97	330,39
CBC098	98	333,51
CBC099	99	337,04
CBC100	100	347,18

Estas coronas se suministran siempre, sin excepción, con husillo de mango cilíndrico y broca guía.

Ref. HCBC1

**HUSILLOS PARA CORONAS REAFILABLES CON Y SIN TiAlN**

	DESCRIPCIÓN	RANGO Ø mm	€
HCBC0	Mango 7mm Triangular Rosca M09x1,25+Broca Ø 5 mm	10 - 13	17,22
HCBC1	Mango 8mm Triangular Rosca M10x1,25+Broca Ø 5 mm	14 - 22	17,22
HCBC2	Mango 9mm Triangular Rosca M12x1,25+Broca Ø 6 mm	23 - 35	17,22
HCBC3	Mango 10mm Triangular Rosca M16x1,25+Broca Ø 6 mm	36 - 49	19,29
HCBC4	Mango 12mm Triangular Rosca M20x1,50+Broca Ø 8 mm	50 - 90	24,50
HCBC5	Mango 13mm Triangular Rosca M28x2,00+Broca Ø 8 mm	91 -100	28,06
HCBC0-CM2	Cono Morse 2 Rosca M09x1,25 y Broca Ø 5 mm	10 - 13	44,31
HCBC1-CM2	Cono Morse 2 Rosca M10x1,25 y Broca Ø 5 mm	14 - 22	44,31
HCBC2-CM2	Cono Morse 2 Rosca M12x1,25 y Broca Ø 6 mm	23 - 35	45,29
HCBC2-CM3	Cono Morse 3 Rosca M12x1,25 y Broca Ø 6 mm	23 - 35	64,89
HCBC3-CM2	Cono Morse 2 Rosca M16x1,25 y Broca Ø 6 mm	36 - 49	64,89
HCBC3-CM3	Cono Morse 3 Rosca M16x1,25 y Broca Ø 6 mm	36 - 49	64,89
HCBC4-CM3	Cono Morse 3 Rosca M20x1,50 y Broca Ø 8 mm	50 - 90	65,71
HCBC4-CM4	Cono Morse 4 Rosca M20x1,50 y Broca Ø 8 mm	50 - 90	108,98
HCBC5-CM3	Cono Morse 3 Rosca M28x2,00 y Broca Ø 8 mm	91 -100	108,98
HCBC5-CM4	Cono Morse 4 Rosca M28x2,00 y Broca Ø 8 mm	91 -100	108,98

**BROCAS GUÍA**

	DESCRIPCIÓN	RANGO Ø mm	€
PCBC1	Guía HSSCo Ø 5 mm	10 - 22	6,76
PCBC2	Guía HSSCo Ø 6 mm	23 - 49	7,78
PCBC3	Guía HSSCo Ø 8 mm	50 -100	8,61
PCBC1TL	Guía HSSCo+TiAlN Ø5 mm	10 - 22	9,80
PCBC2TL	Guía HSSCo+TiAlN Ø6 mm	23 - 49	11,29
PCBC3TL	Guía HSSCo+TiAlN Ø8 mm	50 -100	12,49

**CORONA REAFILABLE HSSCO + TIALN PARA METALES (ESPECIAL INOX)**

HSSCo

INOX

TiAlN

Ref. CBCTL



Al



Cu-Ni-La

FUNDICIÓN

10 mm  
CAPACIDAD  
DE CORTE

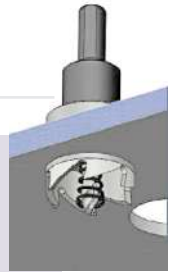

Coronas

Rosa



CBCTL			CBCTL			CBCTL		
	Ø mm	€		Ø mm	€		Ø mm	€
CBC012TL	12	51,16	CBC042TL	42	137,62	CBC072TL	72	357,24
CBC013TL	13	51,16	CBC043TL	43	140,94	CBC073TL	73	363,71
CBC014TL	14	51,16	CBC044TL	44	143,81	CBC074TL	74	373,60
CBC015TL	15	52,59	CBC045TL	45	147,71	CBC075TL	75	383,93
CBC016TL	16	56,93	CBC046TL	46	150,45	CBC076TL	76	383,93
CBC017TL	17	59,37	CBC047TL	47	154,06	CBC077TL	77	383,93
CBC018TL	18	60,32	CBC048TL	48	158,73	CBC078TL	78	383,93
CBC019TL	19	65,52	CBC049TL	49	159,69	CBC079TL	79	383,93
CBC020TL	20	67,79	CBC050TL	50	161,90	CBC080TL	80	397,98
CBC021TL	21	70,62	CBC051TL	51	220,67	CBC081TL	81	397,98
CBC022TL	22	74,98	CBC052TL	52	230,43	CBC082TL	82	397,98
CBC023TL	23	77,38	CBC053TL	53	237,90	CBC083TL	83	397,98
CBC024TL	24	79,44	CBC054TL	54	246,92	CBC084TL	84	397,98
CBC025TL	25	82,37	CBC055TL	55	258,18	CBC085TL	85	397,98
CBC026TL	26	92,15	CBC056TL	56	258,18	CBC086TL	86	397,98
CBC027TL	27	95,32	CBC057TL	57	258,18	CBC087TL	87	397,98
CBC028TL	28	97,02	CBC058TL	58	258,18	CBC088TL	88	397,98
CBC029TL	29	98,63	CBC059TL	59	258,18	CBC089TL	89	397,98
CBC030TL	30	100,18	CBC060TL	60	258,18	CBC090TL	90	408,71
CBC031TL	31	102,14	CBC061TL	61	310,19	CBC091TL	91	408,71
CBC032TL	32	104,90	CBC062TL	62	320,82	CBC092TL	92	408,71
CBC033TL	33	107,45	CBC063TL	63	329,67	CBC093TL	93	408,71
CBC034TL	34	110,85	CBC064TL	64	341,07	CBC094TL	94	417,58
CBC035TL	35	115,82	CBC065TL	65	352,21	CBC095TL	95	421,83
CBC036TL	36	117,80	CBC066TL	66	352,21	CBC096TL	96	421,83
CBC037TL	37	121,10	CBC067TL	67	352,21	CBC097TL	97	421,83
CBC038TL	38	124,62	CBC068TL	68	352,21	CBC098TL	98	426,41
CBC039TL	39	133,76	CBC069TL	69	352,21	CBC099TL	99	431,23
CBC040TL	40	135,55	CBC070TL	70	357,24	CBC100TL	100	455,79
CBC041TL	41	135,55	CBC071TL	71	357,24			

Estas coronas se suministran siempre, sin excepción, con husillo de mango cilíndrico y broca guía.

**EXPOSITOR CORONAS REAFILABLES**

CBC41P

Contenido: 39 Coronas Ref. CBC  
Ø 12 - Ø 50 mm

2.566,88 €



\* Estuches y expositores bajo demanda

**CORONA REAFILABLE HSS PARA METALES DE FINO ESPESOR**
**HSS**

Ref. CCF

**Al**

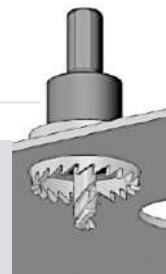
**Cu-Ni-La**
**FUNDICIÓN**
**2 mm  
CAPACIDAD  
DE CORTE**

CCF			CCF		
	Ø mm	€		Ø mm	€
CCF12	12	31,53	CCF31	31	61,98
CCF13	13	31,59	CCF32	32	62,65
CCF14	14	31,59	CCF33	33	64,74
CCF15	15	31,59	CCF34	34	66,60
CCF16	16	31,59	CCF35	35	67,33
CCF17	17	33,81	CCF36	36	70,75
CCF18	18	36,41	CCF37	37	73,91
CCF19	19	38,40	CCF38	38	74,17
CCF20	20	40,49	CCF39	39	76,46
CCF21	21	40,81	CCF40	40	78,56
CCF22	22	42,55	CCF41	41	78,03
CCF23	23	44,81	CCF42	42	78,38
CCF24	24	47,16	CCF43	43	82,24
CCF25	25	49,18	CCF44	44	83,81
CCF26	26	51,23	CCF45	45	84,26
CCF27	27	53,33	CCF46	46	87,80
CCF28	28	56,21	CCF47	47	88,10
CCF29	29	58,35	CCF48	48	88,41
CCF30	30	58,45	CCF49	49	92,12

Estas coronas se suministran siempre, sin excepción, con husillo de mango cilíndrico y broca guía.



Ref. AT12



Ref. CM12

**HUSILLOS PARA CORONAS REAFILABLES**

DESCRIPCIÓN	RANGO Ø mm	€	
AT09	Mango Ø7mm Triangular rosca M9x1,25+broca Ø5mm	10 - 13	17,22
AT10	Mango Ø8mm Triangular rosca M10x1,25+broca Ø5mm	14 - 22	17,22
AT12	Mango Ø9mm Triangular rosca M12x1,25+broca Ø6mm	23 - 40	19,29
AT16	Mango Ø10mm Triangular rosca M16x1,25+broca Ø6mm	41 - 60	24,50
CM09	Cono Morse 2 - rosca M09x1,25 + broca Ø5mm	10 - 13	44,31
CM10	Cono Morse 2 - rosca M10x1,25 + broca Ø5mm	14 - 22	44,31
CM12	Cono Morse 2 - rosca M12x1,25 + broca Ø6mm	23 - 40	45,29
CM16	Cono Morse 2 - rosca M16x1,25 + broca Ø6mm	41 - 60	45,29

**BROCAS GUÍA**

DESCRIPCIÓN	RANGO Ø mm	€	
B5	HSS Ø 5 mm	10 - 22	6,76
B6	HSS Ø 6 mm	23 - 60	7,78
B6TIN	HSS + TiN Ø 6 mm	23 - 60	11,97





**CORONA PERFORADORA DIENTES DE METAL DURO RAZORBACK**

Ref. CBMD



**35 mm**  
**CAPACIDAD**  
**DE CORTE**

Coronas  
Rosa



- Dentado de metal duro.
- Especial para trabajos intensivos en acero inoxidable.
- Resisten mejor la abrasión que las coronas bimetálicas.
- Taladra allá donde las bimetálicas no llegan.
- Aumenta y mejora la productividad en el taladrado.
- Se recomienda no taladrar materiales metálicos superiores a 3 mm.

Ø mm			Blister	
	Ref.	€	Ref.	€
19	CBMD19	16,86	CBMD19B	16,86
22	CBMD22	19,53	CBMD22B	19,53
25	CBMD25	22,18	CBMD25B	22,18
30	CBMD30	26,62	CBMD30B	26,62
32	CBMD32	28,30	CBMD32B	28,30
35	CBMD35	31,07	CBMD35B	31,07
37	CBMD37	32,85	CBMD37B	32,85
38	CBMD38	33,74	CBMD38B	33,74
44	CBMD44	39,04	CBMD44B	39,04
48	CBMD48	42,61	CBMD48B	42,61
51	CBMD51	45,27	CBMD51B	45,27
54	CBMD54	47,93	CBMD54B	47,93
57	CBMD57	50,50	CBMD57B	50,50
60	CBMD60	53,25	CBMD60B	53,25
64	CBMD64	56,81	CBMD64B	56,81
67	CBMD67	59,48	CBMD67B	59,48
70	CBMD70	62,13	CBMD70B	62,13
76	CBMD76	67,46	CBMD76B	67,46
83	CBMD83	73,68	CBMD83B	73,68
86	CBMD86	76,35		
89	CBMD89	79,01		
95	CBMD95	84,34		
102	CBMD102	90,55		
108	CBMD108	95,86		
111	CBMD111	98,54		
114	CBMD114	101,20		
121	CBMD121	107,41		
127	CBMD127	112,73		
140	CBMD140	124,28		
146	CBMD146	129,60		
152	CBMD152	134,92		

• Los husillos de la CBMD son los mismos que los de las coronas CB y COB.

**CORONA METAL DURO CON PUNZÓN RETRÁCTIL PARA TRABAJOS SERIADOS**

Coronas

Rosa

Ref. CP

MD



Al



Cu-Ni-La

FUNDICIÓN

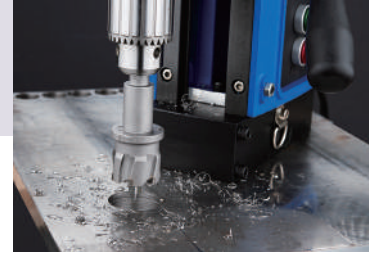
**12 mm**  
**CAPACIDAD**  
**DE CORTE**

	CP	
	Ø mm	€
CP1500	15	105,74
CP1600	16	105,74
CP1700	17	105,74
CP1800	18	105,74
CP1900	19	105,74
CP2000	20	105,74
CP2100	21	105,74
CP2200	22	117,15
CP2300	23	117,15
CP2400	24	117,15
CP2500	25	125,44
CP2600	26	125,44
CP2700	27	125,44
CP2800	28	125,44
CP2900	29	125,44
CP3000	30	125,44
CP3100	31	148,25
CP3200	32	148,25
CP3300	33	148,25
CP3400	34	148,25
CP3500	35	148,25

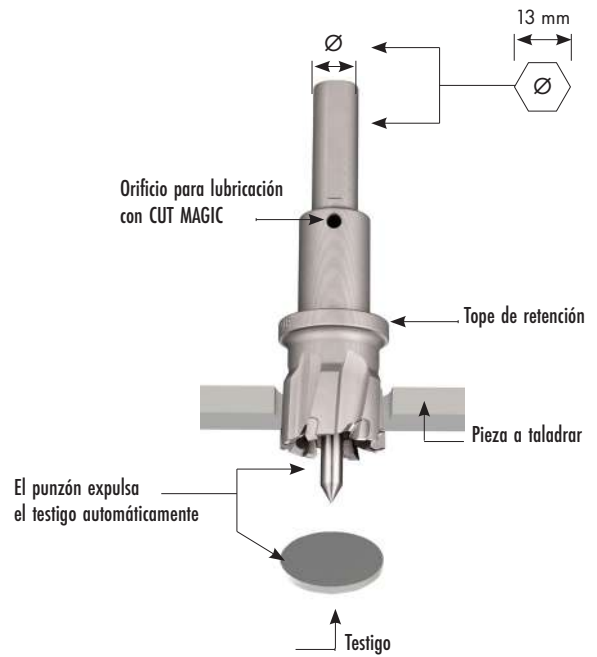
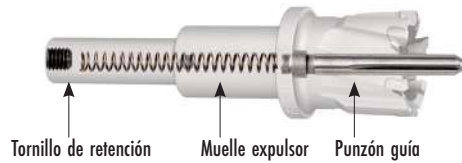
**PUNZÓN DE REPUESTO**

		PCP01
		€
PCP01	Ø 6 x 53 mm	17,79

**SUPER CORONAS DE METAL DURO PARA TODO TIPO DE MATERIALES (ESPECIAL INOX)**

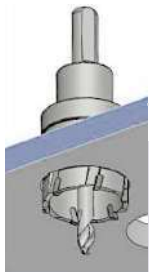

MD  INOX  Al  Cu-Ni-La  FUNDICIÓN

\* Cuerpo de 1 pieza



**12 mm CAPACIDAD DE CORTE**

CX18-CX40: Ø10 mm  
CX41-CX100: Ø13 mm

28 mm

12 mm

**GEOMETRÍA ESPECÍFICA INOX**

**25 mm CAPACIDAD DE CORTE**

Ø13 mm

35 mm

25 mm

Ref. CX

Ref. CXL

CX				CX			
	Ø mm	Z	€		Ø mm	Z	€
CX18	18	4	77,27	CX48	48	10	156,16
CX19	19	4	77,27	CX49	49	10	156,16
CX20	20	6	78,42	CX50	50	10	156,16
CX21	21	6	80,34	CX51	51	10	173,64
CX22	22	6	80,34	CX52	52	10	173,64
CX23	23	6	80,34	CX53	53	10	173,64
CX24	24	6	80,34	CX55	55	10	173,64
CX25	25	6	80,34	CX56	56	12	201,18
CX26	26	6	88,66	CX57	57	12	201,18
CX27	27	6	88,66	CX58	58	12	201,18
CX28	28	6	88,66	CX59	59	12	201,18
CX29	29	6	88,66	CX60	60	12	201,18
CX30	30	6	88,66	CX61	61	12	236,10
CX31	31	6	104,19	CX62	62	12	236,10
CX32	32	6	107,77	CX63	63	12	236,10
CX33	33	6	107,77	CX64	64	12	236,10
CX34	34	8	107,77	CX65	65	12	236,10
CX35	35	8	107,77	CX66	66	12	255,84
CX36	36	8	117,59	CX67	67	12	255,84
CX38	38	8	117,59	CX68	68	12	255,84
CX39	39	8	117,59	CX69	69	12	255,84
CX40	40	8	117,59	CX70	70	12	255,84
CX41	41	8	135,97	CX75	75	14	289,22
CX42	42	8	135,97	CX80	80	14	301,01
CX43	43	8	135,97	CX85	85	14	328,13
CX44	44	10	135,97	CX90	90	16	336,26
CX45	45	10	135,97	CX95	95	16	353,14
CX46	46	10	156,16	CX100	100	16	365,72

CXL				CXL			
	Ø mm	Z	€		Ø mm	Z	€
CXL18	18	6	108,45	CXL48	48	8	210,83
CXL19	19	6	108,45	CXL49	49	8	210,83
CXL20	20	6	108,45	CXL50	50	8	210,83
CXL21	21	6	108,45	CXL51	51	8	234,41
CXL22	22	6	108,45	CXL52	52	8	234,41
CXL23	23	6	108,45	CXL53	53	8	234,41
CXL24	24	6	108,45	CXL55	55	8	234,41
CXL25	25	6	108,45	CXL56	56	8	271,60
CXL26	26	6	125,68	CXL57	57	8	271,60
CXL27	27	6	125,68	CXL58	58	8	271,60
CXL28	28	6	125,68	CXL59	59	8	271,60
CXL29	29	6	125,68	CXL60	60	8	271,60
CXL30	30	6	125,68	CXL61	61	10	318,74
CXL31	31	6	145,50	CXL62	62	10	318,74
CXL32	32	6	145,50	CXL63	63	10	318,74
CXL33	33	6	145,50	CXL64	64	10	318,74
CXL34	34	6	145,50	CXL65	65	10	318,74
CXL35	35	6	145,50				
CXL36	36	6	158,75				
CXL38	38	6	158,75				
CXL39	39	6	158,75				
CXL40	40	8	158,75				
CXL41	41	8	183,56				
CXL42	42	8	183,56				
CXL43	43	8	183,56				
CXL44	44	8	183,56				
CXL45	45	8	183,56				
CXL46	46	8	210,83				

**BROCAS GUÍA CX**



CX		
		€
BRCX06X70	Ø 6 x 70 mm	15,58

**BROCAS GUÍA CXL**



CXL		
		€
BRCXL06X75	Ø 6 x 75 mm	18,13

**SUPER CORONAS DE METAL DURO PARA TUBO Y CHAPA (ESPECIAL INOX)**

Coronas

Rosa

Ref. X  
Ref. XT

MD



INOX

Al



Cu-Ni-La

FUNDICIÓN

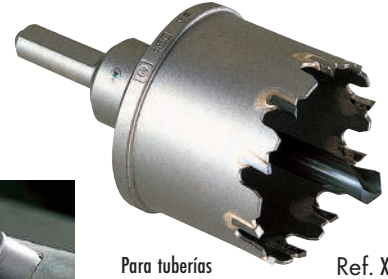
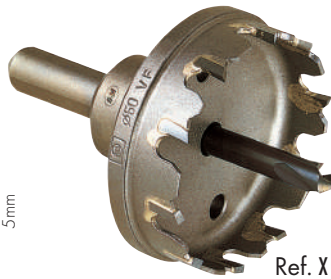
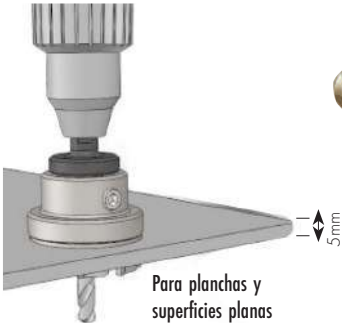
**5 mm**  
**CAPACIDAD**  
**DE CORTE**

	Ø mm	Z	€
X14	14,0	3	84,62
X14,5	14,5	3	84,62
X15	15,0	3	84,62
X16	16,0	3	84,62
X17	17,0	4	84,62
X18	18,0	4	84,62
X19	19,0	4	84,62
X20	20,0	4	84,62
X21	21,0	4	84,62
X22	22,0	4	84,62
X23	23,0	4	84,62
X24	24,0	4	84,62
X25	25,0	4	84,62
X26	26,0	4	98,05
X27	27,0	4	98,05
X28	28,0	6	98,05
X29	29,0	6	98,05
X30	30,0	6	98,05
X31	31,0	6	113,53
X32	32,0	6	113,53
X33	33,0	6	113,53
X34	34,0	6	113,53
X35	35,0	8	113,53
X36	36,0	8	132,11
X37	37,0	8	132,11
X38	38,0	8	132,11
X39	39,0	8	132,11
X40	40,0	8	132,11
X41	41,0	8	152,75
X42	42,0	10	152,75
X43	43,0	10	152,75
X44	44,0	10	152,75
X45	45,0	10	152,75
X46	46,0	10	175,46
X47	47,0	10	175,46
X48	48,0	10	175,46
X49	49,0	10	175,46
X50	50,0	10	175,46
X51	51,0	10	195,08
X52	52,0	10	195,08
X53	53,0	10	195,08
X54	54,0	10	195,08

	Ø mm	Z	€
X55	55,0	12	195,08
X56	56,0	12	226,03
X57	57,0	12	226,03
X58	58,0	12	226,03
X59	59,0	12	226,03
X60	60,0	12	226,03
X61	61,0	12	265,25
X62	62,0	12	265,25
X63	63,0	12	265,25
X64	64,0	12	265,25
X65	65,0	12	265,25
X66	66,0	12	287,42
X67	67,0	12	287,42
X68	68,0	12	287,42
X69	69,0	12	287,42
X70	70,0	12	287,42
X71	71,0	14	310,64
X72	72,0	14	310,64
X73	73,0	14	310,64
X74	74,0	14	310,64
X75	75,0	14	310,64
X76	76,0	14	333,89
X77	77,0	14	333,89
X78	78,0	14	333,89
X79	79,0	14	333,89
X80	80,0	14	333,89
X81	81,0	14	369,47
X82	82,0	16	369,47
X83	83,0	16	369,47
X84	84,0	16	369,47
X85	85,0	16	369,47
X89	89,0	16	405,60
X90	90,0	16	405,60
X91	91,0	16	422,12
X92	92,0	16	422,12
X95	95,0	16	422,12
X100	100,0	18	449,99
X102	102,0	18	496,42
X105	105,0	18	496,42
X110	110,0	20	546,99
X115	115,0	20	601,71
X120	120,0	20	663,10

	Ø mm	Z	€
XT16	16,0	3	127,04
XT17	17,0	4	127,04
XT18	18,0	4	127,04
XT19	19,0	4	127,04
XT20	20,0	4	127,04
XT21	21,0	4	127,04
XT22	22,0	4	127,04
XT23	23,0	4	127,04
XT24	24,0	4	127,04
XT25	25,0	4	127,04
XT26	26,0	4	147,23
XT27	27,0	4	147,23
XT28	28,0	6	147,23
XT29	29,0	6	147,23
XT30	30,0	6	147,23
XT31	31,0	6	170,39
XT32	32,0	6	170,39
XT33	33,0	6	170,39
XT34	34,0	6	170,39
XT35	35,0	8	170,39
XT36	36,0	8	198,19
XT37	37,0	8	198,19
XT38	38,0	8	198,19
XT39	39,0	8	198,19
XT40	40,0	8	198,19
XT41	41,0	8	229,14
XT42	42,0	10	229,14
XT43	43,0	10	229,14
XT44	44,0	10	229,14
XT45	45,0	10	229,14
XT46	46,0	10	260,11
XT47	47,0	10	260,11
XT48	48,0	10	260,11
XT49	49,0	10	260,11
XT50	50,0	10	260,11
XT51	51,0	10	292,84
XT52	52,0	10	292,84
XT53	53,0	10	292,84
XT54	54,0	10	292,84
XT55	55,0	12	292,84
XT60	60,0	12	433,48
XT61	61,0	12	433,48

	Ø mm	Z	€
XT62	62,0	12	433,48
XT65	65,0	12	433,48
XT70	70,0	12	454,10
XT75	75,0	14	491,26
XT80	80,0	14	528,43
XT85	85,0	16	584,13
XT90	90,0	16	639,89
XT95	95,0	16	670,85
XT100	100,0	18	712,13
XT105	105,0	18	784,37
XT110	110,0	20	866,94
XT115	115,0	20	953,65
XT120	120,0	20	1.052,73
XT130	130,0	20	1.650,42
XT140	140,0	25	1.939,11
XT150	150,0	28	2.353,09

**BROCAS GUÍA HSSCo PARA METALES**

	RANGO Ø mm	€		RANGO Ø mm	€
X6	14 - 59	13,74	XT8	23 - 59	25,09
X8	60 - 120	16,21	XT8L	60 - 100	32,36
XT6	6 - 22	18,77	XT8XL	105 - 120	36,56

**TABLA DE SELECCIÓN SUPER CORONAS MULTITAREA DE METAL DURO**

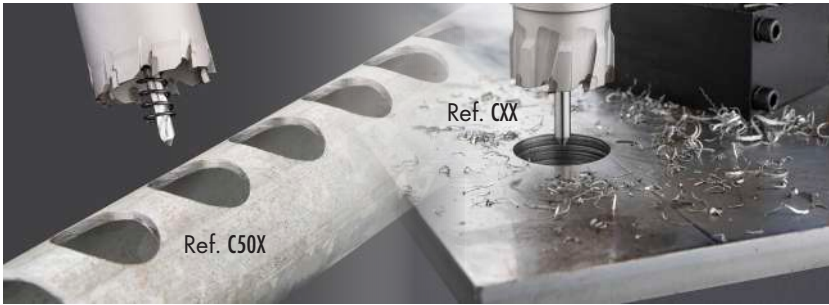

5 mm  
CAPACIDAD  
DE CORTE

Ref. C50X



50 mm  
CAPACIDAD  
DE CORTE

Ref. CXX

	<p>9mm Ø14-60 Ref. BCX1</p>	+	<p>Ref. C50X</p>	+	<p>Ref. CXX2</p>	=	
	<p>11mm Ø14-100 Ref. BCX2</p>	+	<p>Ref. CXX</p>	+	<p>Ref. CXX1</p>	=	
	<p>9mm Ø14-60 Ref. BCX1</p>	+	<p>Ref. C50X</p>	+	<p>Ref. P750CA</p>	=	
	<p>11mm Ø14-100 Ref. BCX2</p>	+	<p>Ref. CXX</p>	+	<p>Ref. CXXW</p>	=	
	<p>FEIN 18-00 mm Ref. CXX18W</p>	+	<p>Ref. C50X</p>	+	<p>Ref. P750CA</p>	=	
	<p>DOBLE WELDON 19-05 mm Ref. CXXW</p>	+	<p>Ref. CXX</p>	+	<p>Ref. CXXW</p>	=	
	<p>Ø14-100 Ref. CXXCM2</p>	+	<p>Ref. C50X</p>	+	<p>Ref. CXX2</p>	=	
	<p>Ø14-150 Ref. CXXCM3</p>	+	<p>Ref. CXX</p>	+	<p>Ref. CXX1</p>	=	

**SUPER CORONA MULTITAREA DE METAL DURO PARA MACIZOS**
**MD**

Ref. CXX

**Al**

Cu-Ni-La

**FUNDICIÓN**
**50 mm**  
**CAPACIDAD**  
**DE CORTE**

**HUSILLOS DE MANGO HEXAGONAL PARA CORONAS MULTITAREA**

	DESCRIPCIÓN	RANGO Ø mm	€
BCX1	Mango hexagonal 9 mm	14 - 60	20,31
BCX2	Mango hexagonal 11 mm	14 - 100	20,31

**HUSILLOS DE MANGO CÓNICO PARA CORONAS MULTITAREA**

	DESCRIPCIÓN	RANGO Ø mm	€
CXXCM2	Mango Cono Morse 2	14 - 100	36,79
CXXCM3	Mango Cono Morse 3	14 - 150	39,14

**BROCA GUÍA**

		CXX
		€
CXX1	Ø 6 x 90L mm	6,59

CXX			CXX		
	Ø mm	€		Ø mm	€
CXX14	14	127,93	CXX45	45	216,53
CXX15	15	127,93	CXX46	46	248,69
CXX16	16	127,93	CXX47	47	248,69
CXX17	17	127,93	CXX48	48	248,69
CXX18	18	127,93	CXX49	49	248,69
CXX19	19	127,93	CXX50	50	248,69
CXX20	20	127,93	CXX51	51	276,52
CXX21	21	127,93	CXX52	52	276,52
CXX22	22	127,93	CXX53	53	276,52
CXX23	23	127,93	CXX54	54	276,52
CXX24	24	127,93	CXX55	55	276,52
CXX25	25	127,93	CXX56	56	320,39
CXX26	26	148,25	CXX57	57	320,39
CXX27	27	148,25	CXX58	58	320,39
CXX28	28	148,25	CXX59	59	320,39
CXX29	29	148,25	CXX60	60	320,39
CXX30	30	148,25	CXX61	61	376,00
CXX31	31	171,63	CXX62	62	376,00
CXX32	32	171,63	CXX63	63	376,00
CXX33	33	171,63	CXX64	64	376,00
CXX34	34	171,63	CXX65	65	376,00
CXX35	35	171,63	CXX66	66	441,74
CXX36	36	187,26	CXX67	67	441,74
CXX37	37	187,27	CXX68	68	441,74
CXX38	38	187,26	CXX69	69	441,74
CXX39	39	187,26	CXX70	70	441,74
CXX40	40	187,26	CXX75	75	458,36
CXX41	41	216,53	CXX80	80	495,85
CXX42	42	216,53	CXX85	85	531,16
CXX43	43	216,53	CXX90	90	571,19
CXX44	44	216,53	CXX100	100	613,57

**HUSILLOS PARA TALADRO DE BASE ELECTROMAGNÉTICA**

Tipo Fein



Tipo Weldon

	DESCRIPCIÓN	CXX
		€
CXX18W	Mango Fein 18,00mm	36,79
CXXW	Mango Weldon 19,05mm	36,79

**PUNZÓN**

	DESCRIPCIÓN	P
		€
P750CA	Ø 6.35mm x 100mm	28,35

**SUPER CORONA MULTITAREA DE METAL DURO PARA TUBO Y CHAPA**

**MD**

Ref. C50X



**5 mm  
CAPACIDAD  
DE CORTE**



**HUSILLOS DE MANGO HEXAGONAL PARA CORONAS MULTITAREA**



	DESCRIPCIÓN	RANGO Ø mm	€
BCX1	Mango hexagonal 9 mm	14 - 60	20,31
BCX2	Mango hexagonal 11 mm	14 - 100	20,31

**HUSILLOS DE MANGO CÓNICO PARA CORONAS MULTITAREA**



	DESCRIPCIÓN	RANGO Ø mm	€
CXXCM2	Mango Cono Morse 2	14 - 100	36,79
CXXCM3	Mango Cono Morse 3	14 - 150	39,14

**BROCA GUÍA**



		CXX
		€
CXX2	Ø 6 x 75L mm	6,18

**HUSILLOS PARA TALADRO DE BASE ELECTROMAGNÉTICA**



Tipo Fein

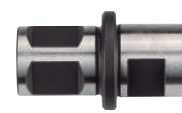

Tipo Weldon

	DESCRIPCIÓN	CXX
		€
CXX18W	Mango Fein 18,00mm	36,79
CXXW	Mango Weldon 19,05mm	36,79

**PUNZÓN**



	DESCRIPCIÓN	P
		€
P750CA	Ø 6.35mm x 100mm	28,35

	C50X	
	Ø mm	€
C50X14	14	60,93
C50X15	15	60,93
C50X16	16	60,93
C50X17	17	60,93
C50X18	18	60,93
C50X19	19	68,78
C50X20	20	68,78
C50X21	21	68,78
C50X22	22	68,78
C50X23	23	68,78
C50X24	24	68,78
C50X25	25	68,78
C50X26	26	74,82
C50X27	27	74,82
C50X28	28	74,82
C50X29	29	74,82
C50X30	30	74,82
C50X31	31	92,27
C50X32	32	92,27
C50X33	33	92,27
C50X34	34	92,27
C50X35	35	92,27
C50X36	36	111,03
C50X37	37	111,03
C50X38	38	111,03
C50X39	39	111,03
C50X40	40	111,03
C50X41	41	133,93
C50X42	42	133,93
C50X43	43	133,93
C50X44	44	133,93

	C50X	
	Ø mm	€
C50X45	45	133,93
C50X46	46	157,12
C50X47	47	157,12
C50X48	48	157,12
C50X49	49	157,12
C50X50	50	157,12
C50X51	51	179,57
C50X52	52	179,57
C50X53	53	179,57
C50X54	54	179,57
C50X55	55	179,57
C50X56	56	209,06
C50X57	57	209,06
C50X58	58	209,06
C50X59	59	209,06
C50X60	60	209,06
C50X61	61	253,68
C50X62	62	253,68
C50X63	63	253,68
C50X64	64	253,68
C50X65	65	253,68
C50X66	66	276,60
C50X67	67	276,60
C50X68	68	276,60
C50X69	69	276,60
C50X70	70	276,60
C50X75	75	370,83
C50X80	80	393,99
C50X85	85	417,18
C50X90	90	449,47
C50X100	100	609,40

## CORONA PARA TRABAJOS PESADOS CON DIENTES DE METAL DURO Y CAMBIO POLY-CLICK ACOPLABLES A CONOS MORSE Nº4 Y Nº5, CON REFRIGERACIÓN INTERIOR

Coronas

Rosa

Ref. MBM

MD

55  
HRc

INOX

Al

FUNDICIÓN

50 mm  
CAPACIDAD  
DE CORTE

- Emplear en todos los casos, la refrigeración interior.
- No agotar la vida de los dientes del todo, para permitir sucesivos reafilados.
- El encuentro de la corona con el material ha de ser progresivo y sutil de forma que podamos evitar roturas de dientes por choques.



MBM			
	Ø mm	Z	€
MBM35	35,0	4	64,93*
MBM36	36,0	4	64,93*
MBM38	38,0	4	64,93*
MBM40	40,0	6	76,52*
MBM42	42,0	6	76,52*
MBM43	43,0	6	76,52*
MBM44	44,0	6	76,52*
MBM45	45,0	6	84,39*
MBM48	48,0	6	84,39*
MBM49	49,0	6	84,39*
MBM50	50,0	6	94,60*
MBM51	51,0	6	94,60*
MBM52	52,0	6	94,60*
MBM53	53,0	6	94,60*
MBM54	54,0	6	94,60*
MBM55	55,0	6	94,60*
MBM56	56,0	6	104,80*
MBM58	58,0	6	104,80*
MBM60	60,0	6	122,42*
MBM61	61,0	6	122,42*
MBM62	62,0	6	122,42*

MBM			
	Ø mm	Z	€
MBM65	65,0	6	122,42*
MBM66	66,0	6	132,62*
MBM68	68,0	6	132,62*
MBM70	70,0	6	132,62*
MBM75	75,0	6	142,82*
MBM77	77,0	6	153,03*
MBM78	78,0	6	153,03*
MBM80	80,0	6	153,03*
MBM82	82,0	6	240,47*
MBM85	85,0	6	240,47*
MBM90	90,0	6	262,33*
MBM95	95,0	6	282,21*
MBM105	105,0	6	222,59*
MBM110	110,0	6	244,85*
MBM115	115,0	6	268,03*
MBM120	120,0	6	298,63*
MBM125	125,0	6	340,83*
MBM130	130,0	6	384,89*
MBM140	140,0	6	459,08*

\*Hasta fin de existencias



### HUSILLOS MANGO CÓNICO CON PUNZÓN

	DESCRIPCIÓN	€
500MT4	Husillos cono morse 4	192,91*
500MT5	Husillos cono morse 5	199,40*



PERFORADOR DE CHAPAS FINAS HASTA 4 mm

Ref. PC

HASTA  
4 mm  
CHAPAS FINAS



Modo de empleo:

- Realice el agujero previo mediante nuestra broca avellanadora Ref. AV30.
- Introduzca el tornillo Ref. PCM por el agujero practicado.
- Por el lado contrario enrosque la cuchilla Ref. PCC sobre el tornillo.
- Aplique un par de apriete hasta que la cuchilla Ref. PCC seccione la chapa contra la cazoleta Ref. PBC.
- Utilice CUT MAGIC para trabajar con el perforador Ref. PC



METRICA TORNILLO	ESPESOR MÁXIMO CHAPA A PERFORAR			
	ACERO NORMAL	INOXIDABLE	NO FERROSOS	PLÁSTICOS
M10x1.0	2.00 mm	1.00 mm	4.00 mm	4.00 mm
M12x1.5	3.00 mm	1.50 mm	4.00 mm	4.00 mm
M16x1.5	3.00 mm	1.50 mm	4.00 mm	4.00 mm

	∅	PC €
PC1270	12,70 PG7	33,93
PC1400	14,00	34,47
PC1520	15,20 PG9	34,81
PC1600	16,00	34,81
PC1650	16,50	35,58
PC1700	17,00	36,08
PC1800	18,00	36,08
PC1860	18,60 PG11	38,06
PC1900	19,00	38,06
PC2000	20,00	38,93
PC2040	20,40 PG13,5	38,93
PC2100	21,00	39,98
PC2200	22,00	41,58
PC2250	22,50 PG16	41,58
PC2300	23,00	43,05
PC2400	24,00	43,05
PC2500	25,00	45,71
PC2540	25,40	45,71

	∅	PC €
PC2600	26,00	47,23
PC2700	27,00	47,23
PC2830	28,30 PG21	47,23
PC2900	29,00	50,70
PC3000	30,00	50,70
PC3100	31,00	50,70
PC3200	32,00	51,39
PC3250	32,50	58,33
PC3300	33,00	58,33
PC3400	34,00	58,33
PC3500	35,00	58,33
PC3600	36,00	62,96
PC3700	37,00 PG29	62,96
PC3800	38,00	62,96
PC3900	39,00	79,91
PC4000	40,00	79,91
PC4050	40,50	80,34
PC4100	41,00	80,34

	∅	PC €
PC4200	42,00	87,31
PC4300	43,00	87,31
PC4400	44,00	89,93
PC4500	45,00	94,94
PC4600	46,00	94,94
PC4700	47,00 PG36	96,51
PC4800	48,00	104,16
PC4900	49,00	104,16
PC5000	50,00	107,35
PC5050	50,50	114,19
PC5100	51,00	114,19
PC5200	52,00	117,53
PC5300	53,00	117,53
PC5400	54,00 PG42	123,65
PC5500	55,00	123,65
PC6000	60,00 PG48	152,95
PC6350	63,50	175,79

TUERCA Y ARANDELA



DESCRIPCIÓN		PCM €
PCM10	(Rosca M10 x 1,00) Perforadores desde ∅ 12,70 - 25,40 mm	4,83
PCM12	(Rosca M12 x 1,50) Perforadores desde ∅ 26 - 41 mm	4,83
PCM16	(Rosca M16 x 1,50) Perforadores desde ∅ 42 - 63,50 mm	5,49

CAZOLETA



PBC

Consulte precio para cada diámetro

CUCHILLA DE CORTE



PCC

Consulte precio para cada diámetro

**CONDICIONES DE CORTE PARA CORONAS DE HSS Y HSSCo**
**TABLA DE AVANCES**







mm/VUELTA	 	  50 HRc	 INOX	 FUNDICIÓN	 Al
CB - COB - CBR	<b>0,053</b>	-	<b>0,05</b>	<b>0,075</b>	<b>0,12</b>
CBC- CCF	<b>0,063</b>	-	<b>0,055</b>	<b>0,085</b>	<b>0,15</b>

**SELECCIÓN DE R.P.M. PARA CORONAS CB - COB - CBR - CBC - CCF**

Vc (m/mín...)	100	95	90	85	80	75	70	65	60	55	50	45	40	35	30	25	20	15	10
		3183	3024	2865	2706	2547	2387	2228	2069	1910	1751	1592	1432	1273	1114	955	796	637	477
	2122	2016	1910	1804	1698	1592	1485	1379	1273	1167	1061	955	849	743	637	531	424	318	212
	1952	1512	1432	1353	1273	1194	1114	1035	955	875	796	716	637	557	477	398	318	239	159
	1273	1512	1432	1353	1276	1194	1114	1035	922	875	796	716	637	557	477	398	318	239	159
	1061	1008	819	773	728	682	637	591	546	500	455	409	364	318	273	227	182	136	91
	909	864	819	773	728	682	637	591	546	500	455	409	364	318	273	227	182	136	91
	796	756	716	676	637	597	557	517	477	438	398	358	318	279	239	199	159	119	80
	637	605	573	541	509	477	446	414	382	350	318	286	255	223	191	159	127	95	64
	531	504	477	451	424	398	371	345	318	292	265	239	212	186	159	136	106	80	53
	455	432	409	387	364	341	318	296	273	250	227	205	192	159	136	114	91	68	45
	398	378	358	338	318	298	279	259	239	219	199	179	159	139	119	99	80	60	40
	354	336	318	301	283	265	248	230	212	195	177	159	141	124	106	88	71	53	35
	318	302	286	271	255	239	223	207	191	175	159	143	127	111	95	80	64	48	32
	<b>10</b>	<b>15</b>	<b>20</b>	<b>25</b>	<b>30</b>	<b>35</b>	<b>40</b>	<b>50</b>	<b>60</b>	<b>70</b>	<b>80</b>	<b>90</b>	<b>100</b>						

SELECCIÓN DE DIÁMETRO (Ø mm)

**CONDICIONES DE CORTE PARA CORONAS DE DIENTES DE METAL DURO**
**TABLA DE AVANCES**

mm/VUELTA	 	  50 HRc	 INOX	 FUNDICIÓN	 Al	 Ni
LIGERAS: CX - CXL - X - XT	<b>0,035</b>	<b>0,025</b>	<b>0,02</b>	<b>0,040</b>	<b>0,075</b>	<b>0,020</b>
C50X - CXX - MBM - CBMD - CP	<b>0,10</b>	<b>0,075</b>	<b>0,095</b>	<b>0,15</b>	<b>0,22</b>	<b>0,07</b>

**SELECCIÓN DE R.P.M. PARA CORONAS CX - CXL - X - XT - C50X - CXX - MBM - CBMD - CP**

Vc (m/mín...)	100	95	90	85	80	75	70	65	60	55	50	45	40	35	30	25	20	15	10
		3183	3024	2865	2706	2547	2387	2228	2069	1910	1751	1592	1432	1273	1114	955	796	637	477
	2122	2016	1910	1804	1698	1592	1485	1379	1273	1167	1061	955	849	743	637	531	424	318	212
	1952	1512	1432	1353	1273	1194	1114	1035	955	875	796	716	637	557	477	398	318	239	159
	1273	1512	1432	1353	1276	1194	1114	1035	922	875	796	716	637	557	477	398	318	239	159
	1061	1008	819	773	728	682	637	591	546	500	455	409	364	318	273	227	182	136	91
	909	864	819	773	728	682	637	591	546	500	455	409	364	318	273	227	182	136	91
	796	756	716	676	637	597	557	517	477	438	398	358	318	279	239	199	159	119	80
	637	605	573	541	509	477	446	414	382	350	318	286	255	223	191	159	127	95	64
	531	504	477	451	424	398	371	345	318	292	265	239	212	186	159	136	106	80	53
	455	432	409	387	364	341	318	296	273	250	227	205	192	159	136	114	91	68	45
	398	378	358	338	318	298	279	259	239	219	199	179	159	139	119	99	80	60	40
	354	336	318	301	283	265	248	230	212	195	177	159	141	124	106	88	71	53	35
	318	302	286	271	255	239	223	207	191	175	159	143	127	111	95	80	64	48	32
	<b>10</b>	<b>15</b>	<b>20</b>	<b>25</b>	<b>30</b>	<b>35</b>	<b>40</b>	<b>50</b>	<b>60</b>	<b>70</b>	<b>80</b>	<b>90</b>	<b>100</b>						

SELECCIÓN DE DIÁMETRO (Ø mm)