

BLUE-MASTER[®]
by *celesa*



FRESE E SEGHE
A TAZZA

GUIDA PER LA SCELTA DI FRESE E SEGHE A TAZZA
FRESE E SEGHE A TAZZA PER METALLO

REFERENZA	Tipo e profondità di taglio	Applicazioni, caratteristiche e gamma	Pag.
CB	BI-METAL HSS 35 mm	 Gamma di Ø14/250mm	552
COB	BI-METAL HSSCo 8% 45 mm	 Gamma di Ø14/152mm	553
CBX100	BI-METAL HSS 100 mm	 Gamma di Ø25/152mm	556
COBX100	BI-METAL HSSCo 8% 100 mm	 Gamma di Ø25/51mm	556
CBR	HSS 5 mm	 Gamma di Ø8/100mm	560
CBR..T	HSS-TiN 5 mm	 Gamma di Ø8/100mm	561
CBC	HSSCo Inox 10 mm	 Gamma di Ø12/100mm	562
CBCTL	HSSCo Inox TiAIN 10 mm	 Gamma di Ø12/100mm	563
CCF	HSS 2 mm	 Gamma di Ø10/50mm	564
CBMD	35 mm	 Gamma di Ø19/152mm	565
CP	12 mm	 Gamma di Ø15/35mm	566

FRESE E SEGHE A TAZZA PER METALLO

REFERENZA	Tipo e profondità di taglio	Applicazioni, caratteristiche e gamma	Pag.
CX CXL	MD 12 mm 25 mm	 Gamma di Ø18/65mm	567
X	MD 5 mm	 Gamma di Ø14/120mm	568
XT	MD 5 mm	 Gamma di Ø16/150mm	568
CXX	MD 50 mm	 Gamma di Ø14/100mm	570
C50X	MD 5 mm	 Gamma di Ø14/100mm	571
MBM	MD 50 mm	 Gamma di Ø35/150mm	572

FRESE A CAROTARE PER MACCHINE A SUPPORTO ELETTROMAGNETICO

REFERENZA	Tipo e profondità di taglio	Applicazioni, caratteristiche e gamma	Pag.
250R 500R	HSS 30 mm 50 mm	 Gamma di Ø12/50mm	576
250C 500C 750C 1000C	HSS 30 mm 50 mm 75 mm 100 mm	 Gamma di Ø12/100mm	577
1500C 2000C	HSS 150 mm 200 mm	 Gamma di Ø22/50mm - Ø26/50mm	580

GUIDA PER LA SCELTA DI FRESE E SEGHE A TAZZA

FRESE A CAROTARE PER MACCHINE A SUPPORTO ELETTROMAGNETICO

REFERENZA	Tipo e profondità di taglio	Applicazioni, caratteristiche e gamma	Pag.
250T 500T	HSSCo 30 mm 50 mm	<p>Gamma di Ø12/60mm</p>	578
350A 500A	MD 35 mm 50 mm	<p>Gamma di Ø14/52mm - Ø14/70mm</p>	581
750A 1000A	MD 75 mm 100 mm	<p>Gamma di Ø16/70mm</p>	582
MB250AT MB500AT	HSSCo 25/50 mm	<p>Gamma di Ø16/32mm</p>	583
MB350ST	MD 35 m	<p>Gamma di Ø16/32mm</p>	583

FRESE A TAZZA PER EDILIZIA

REFERENZA	Tipo e profondità di taglio	Applicazioni, caratteristiche e gamma	Pag.
600W	MD 80 mm	<p>Gamma di Ø25/100mm</p>	592
CW	MD 95 mm	<p>Gamma di Ø25/200mm</p>	593
HA	MD 54 mm	<p>Gamma di Ø25/112mm</p>	594
MD	MD 60 mm	<p>Gamma di 22/120mm</p>	595

FRESE A TAZZA PER EDILIZIA

REFERENZA	Tipo e profondità di taglio	Applicazioni, caratteristiche e gamma	Pag.
MH	MD 100 mm	<p>Gamma di Ø25/150mm</p>	596
CLA PM	MD 70 mm	<p>Gamma di Ø30/150m</p>	597
CDE CMAD	PORCELLANICO 40 mm	<p>Gamma di Ø12/120mm - Ø20/50mm</p>	598
CDD	DIAMANTE 60 mm	<p>Gamma di Ø8/102mm</p>	599
CAH	DIAMANTE	<p>Gamma di Ø5/35mm</p>	599
CHH	DIAMANTE 300-450 mm		600
CSE	PORCELLANICO 35 mm	<p>Gamma di Ø5/83mm</p>	601
MG	CARBURO 30 mm	<p>Gamma di Ø16/114mm</p>	603
CM	LEGNO 60 mm Ø22/125	<p>Gamma di Ø22/125mm</p>	604
TB CL	SEGA REGOLABILE A COMPASSO Ø200/220/285/410 mm		605
CDH	150 mm		608

SEGA A TAZZA BIMETALLICA ACCIAIO RAPIDO HSS 4/6 DENTATURA VARIABILE

Ref. CB

**HSS
M3**
4/6

Al

Cu-Ni-La
GHISA

PVC
**35 mm
CAPACITÀ
DI TAGLIO**

Dimensioni blister: 165 x 105 mm

SEGA A TAZZA Ref. CB PRESENTATA IN SCATOLA E BLISTER

Ø mm	Ø Pollici	CB		CB	
		Scatola		Blister	
		Ref.	€	Ref.	€
14	9/16	CB14	6,48	CB14B	6,48
16	5/8	CB16	6,48	CB16B	6,48
17	11/16	CB17	6,55	CB17B	6,55
19	3/4	CB19	7,20	CB19B	7,20
20	-	CB20	7,20	CB20B	7,20
21	13/16	CB21	7,20	CB21B	7,20
22	7/8	CB22	7,57	CB22B	7,57
24	15/16	CB24	8,18	CB24B	8,18
25	1"	CB25	8,53	CB25B	8,53
27	1.1/16	CB27	8,91	CB27B	8,91
29	1.1/8	CB29	9,41	CB29B	9,41
30	1.3/16	CB30	9,95	CB30B	9,95
32	1.1/4	CB32	10,21	CB32B	10,21
33	1.5/16	CB33	10,94	CB33B	10,94
35	1.3/8	CB35	11,03	CB35B	11,03
37	1.7/16	CB37	11,67	CB37B	11,67
38	1.1/2	CB38	11,84	CB38B	11,84
40	1.9/16	CB40	12,01	CB40B	12,01
41	1.5/8	CB41	12,01	CB41B	12,01
43	1.11/16	CB43	12,21	CB43B	12,21
44	1.3/4	CB44	12,66	CB44B	12,66
45	-	CB45	13,05	CB45B	13,05
46	1.13/16	CB46	13,32	CB46B	13,32
48	1.7/8	CB48	13,67	CB48B	13,67
50	-	CB50	13,88	CB50B	13,88
51	2"	CB51	13,88	CB51B	13,88
52	2.1/16	CB52	14,28	CB52B	14,28
54	2.1/8	CB54	14,76	CB54B	14,76
55	-	CB55	15,18	CB55B	15,18
57	2.1/4	CB57	15,31	CB57B	15,31
59	2.5/16	CB59	15,72	CB59B	15,72
60	2.3/8	CB60	16,19	CB60B	16,19

Ø mm	Ø Pollici	CB		CB	
		Scatola		Blister	
		Ref.	€	Ref.	€
64	2.1/2	CB64	16,45	CB64B	16,45
65	2.9/16	CB65	17,10	CB65B	17,10
67	2.5/8	CB67	17,16	CB67B	17,16
68	-	CB68	17,16	CB68B	17,16
70	2.3/4	CB70	17,45	CB70B	17,45
73	2.7/8	CB73	17,49	CB73B	17,49
75	-	CB75	18,52	CB75B	18,52
76	3"	CB76	18,52	CB76B	18,52
79	3.1/8	CB79	18,62	CB79B	18,62
83	3.1/4	CB83	18,62	CB83B	18,62
86	3.3/8	CB86	18,70		
89	3.1/2	CB89	18,76		
92	3.5/8	CB92	20,70		
95	3.3/4	CB95	24,91		
98	3.7/8	CB98	25,79		
100	-	CB100	26,78		
102	4"	CB102	26,78		
104	4.1/8	CB104	29,62		
108	4.1/4	CB108	31,35		
111	4.3/8	CB111	31,94		
114	4.1/2	CB114	32,54		
121	4.3/4	CB121	33,03		
127	5"	CB127	39,36		
140	5.1/2	CB140	41,17		
146	5.3/4	CB146	43,03		
152	6"	CB152	53,19		
160	-	CB160	83,48		
168	-	CB168	91,73		
177	-	CB177	93,42		
210	-	CB210	98,52		
225	-	CB225	130,37		
250	-	CB250	159,08		

Le seghe a tazza da Ø14 a Ø30 non includono fori per l'attacco degli alberi con spine.
Consultare le condizioni di taglio alla pagina 556.

SEGA A TAZZA BIMETALLICA ACCIAIO RAPIDO HSSCo 8% 4/6 DENTATURA VARIABILE

Ref. COB

**HSSCo
8%**

4/6

INOX



GHISA

Cu-Ni-La

- Maggiore durata dell'affilatura e del taglio.
- Tagli più veloci e precisi.
- Minore vibrazione e usura.
- M42. Maggiore durezza e rendimento.

**45 mm
CAPACITÀ
DI TAGLIO**



Dimensioni blister: 165 x 105 mm

SEGA A TAZZA Ref. COB PRESENTATA IN SCATOLA E BLISTER

Ø mm	Ø Pollici	COB		COB	
		Scatola		Blister	
		Ref.	€	Ref.	€
14	9/16	COB14	11,25	COB14B	11,25
16	5/8	COB16	11,63	COB16B	11,63
17	11/16	COB17	11,66	COB17B	11,66
19	3/4	COB19	11,66	COB19B	11,66
20	-	COB20	11,66	COB20B	11,66
21	13/16	COB21	11,66	COB21B	11,66
22	7/8	COB22	11,89	COB22B	11,89
24	15/16	COB24	11,91	COB24B	11,91
25	1"	COB25	12,65	COB25B	12,65
27	1.1/16	COB27	13,34	COB27B	13,34
29	1.1/8	COB29	13,43	COB29B	13,43
30	1.3/16	COB30	13,43	COB30B	13,43
32	1.1/4	COB32	13,43	COB32B	13,43
33	1.5/16	COB33	13,43	COB33B	13,43
35	1.3/8	COB35	14,57	COB35B	14,57
37	1.7/16	COB37	14,57	COB37B	14,57
38	1.1/2	COB38	14,64	COB38B	14,64
40	1.9/16	COB40	14,68	COB40B	14,68
41	1.5/8	COB41	14,68	COB41B	14,68
43	1.11/16	COB43	14,68	COB43B	14,68
44	1.3/4	COB44	16,88	COB44B	16,88
45	-	COB45	17,30	COB45B	17,30
46	1.13/16	COB46	17,40	COB46B	17,40
48	1.7/8	COB48	17,43	COB48B	17,43
50	-	COB50	17,48	COB50B	17,48
51	2"	COB51	17,60	COB51B	17,60
52	2.1/16	COB52	19,55	COB52B	19,55
54	2.1/8	COB54	20,08	COB54B	20,08
55	-	COB55	20,15	COB55B	20,15
57	2.1/4	COB57	20,30	COB57B	20,30
59	2.5/16	COB59	20,32	COB59B	20,32
60	2.3/8	COB60	20,32	COB60B	20,32

Ø mm	Ø Pollici	COB		COB	
		Scatola		Blister	
		Ref.	€	Ref.	€
64	2.1/2	COB64	21,88	COB64B	21,88
65	2.9/16	COB65	22,09	COB65B	22,09
67	2.5/8	COB67	22,09	COB67B	22,09
68	-	COB68	22,09	COB68B	22,09
70	2.3/4	COB70	22,09	COB70B	22,09
73	2.7/8	COB73	22,09	COB73B	22,09
75	-	COB75	22,43	COB75B	22,43
76	3"	COB76	23,64	COB76B	23,64
79	3.1/8	COB79	23,70	COB79B	23,70
83	3.1/4	COB83	23,70	COB83B	23,70
86	3.3/8	COB86	23,70		
89	3.1/2	COB89	23,79		
92	3.5/8	COB92	26,59		
95	3.3/4	COB95	31,69		
98	3.7/8	COB98	32,80		
100	-	COB100	35,34		
102	4"	COB102	36,12		
104	4.1/8	COB104	39,06		
108	4.1/4	COB108	39,18		
111	4.3/8	COB111	39,98		
114	4.1/2	COB114	40,81		
121	4.3/4	COB121	43,34		
127	5"	COB127	45,08		
140	5.1/2	COB140	50,22		
146	5.3/4	COB146	52,63		
152	6"	COB152	63,91		

R.P.M. RACCOMANDATE

INTERVALLO Ø mm	R.P.M.
14-25	600
27-45	350
46-60	250
64-83	150
86-102	120
104-121	90
127-152	60

Le seghe a tazza da Ø14 a Ø30 non includono fori per l'attacco degli alberi con spine.
Consultare le condizioni di taglio alla pagina 556.

ALBERI E ACCESSORI PER SEGHE A TAZZA BIMETALLICHE

ALBERI CON O SENZA MOLLA DI ESPULSIONE IN SCATOLA E IN BLISTER



Ref. B5514



Ref. B5518

→ Ref. B5519
Il più abituale

Ref. B5520



Ref. B5545

→ Ref. B5546
Il più abituale

Ref. B5547*



Ref. B5556SDS



Ref. B5547M



SENZA MOLLA DI ESPULSIONE

CON MOLLA DI ESPULSIONE

Tipo di codolo	Capacità Ø mm	Scatola		Blister		Scatola		Blister	
		Ref.	€	Ref.	€	Ref.	€	Ref.	€
Ø 6,35 mm	14 - 30	B5514	9,60	B5514S	10,26	B5514M	10,62	5514-BME	10,65
Ø 11,0 mm	14 - 30	B5518	12,64	B5518S	13,49	B5518M	13,63	5518-BME	13,63
Ø 9,5 mm	14 - 30	B5519	12,94	B5519S	14,07	B5519M	13,92	5519-BME	15,12
Ø 11,0 mm	32 - 38	B5520	15,17	B5520S	15,17	B5520M	16,16		
Ø 11,0 mm	32 - 250	B5545	20,50	B5545S	20,50	B5545M	21,49		
Ø 9,5 mm	32 - 250	B5546	20,50	B5546S	21,88	B5546M	21,49	5546-BME	22,93
Ø 11,0 mm	32 - 250	B5547*	21,42	B5547S	23,40	B5547M	22,43	5547-BME	24,53
Ø 16,0 mm	32 - 250	B5573	22,35			B5573M	23,34		
SDS-PLUS	14 - 30	B5529SDS	17,19			B5529SDSM	17,72		
SDS-PLUS	32 - 250	B5556SDS	31,82			B5556SDSM	32,51		

MOLLA DI ESPULSIONE

B8530
0,91 €

* Albero rigido ad alto rendimento

PUNTE PILOTA

HSS



Ref. B8534 (La più abituale)



Ref. B8535



Ref. B8536



Ref. B8537



Ref. B8538



Ø mm	Lt mm	CHIAVETTE	UNITÀ IMBALLAGGIO	ALBERI CORRISPONDENTI	Scatola		Blister	
					Ref.	€	Ref.	€
6,35	83	2	10	5514-5518-5519-5520-5545-5546 5573-5529SDS -5556SDS -5547	B8534	3,06	B8534S	4,04
6,35	107	3	10	5514-5518-5519-5520-5545-5546 5573-5529SDS -5556SDS -5547	B8535	3,06	B8535S	4,04
6,35	87	1	10	5514-5518-5520-5573-5545	B8536	3,06	B8536S	4,04
6,35	82	1	10	Seghe a tazza Mastergrit	B8537	2,72	B8537S	5,01
6,35	97	1	10	Seghe a tazza Mastergrit	B8538	2,72	B8538S	5,01

ACCESSORI PER SEGHE A TAZZA BIMETALLICHE

PROLUNGA PER ALBERI DI 300 mm



Valido per alberi:
Ref. 5519-5546
Manico esagonale da 9,5 mm

B5500
24,61 €

ADATTATORE PER ALBERI



Questo adattatore filettato permette agli alberi 5514, 5518 e 5519 di utilizzare seghe a tazza superiori a 30 mm in condizioni di taglio favorevoli.

B5511
8,56 €

VITI DI RICAMBIO (FISSAGGIO DELLA PUNTA ALL'GAMBO)



Vite per alberi:
Ref. 5514 - 5518 - 5519 - 5520

BSS1
2,24 €



Vite per alberi:
Ref. 5545 - 5546 - 5573

BSS2
2,24 €

INSIEME DI SEGA A TAZZA E RONDELLA SVASATORE PER PLADUR

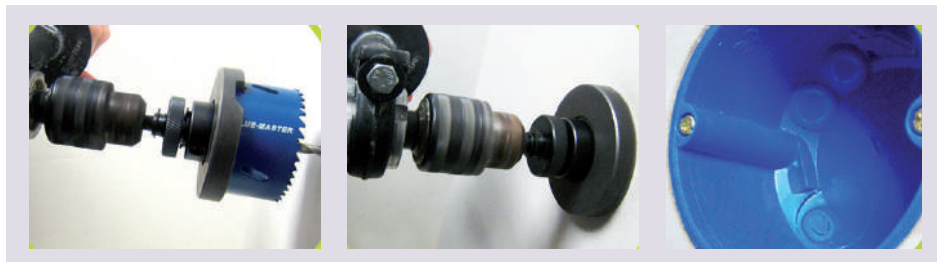

Insieme 1 Ø67

Ref. CPL67

Contenuto:

- 1 Sega a tazza bimetallica CB67 : Ø 67 mm
- 1 Albero Ref. B5547
- 1 Rondella svasatore Ref. CPL

83,16 €



Insieme 2 Ø68

Ref. CPL68

Contenuto:

- 1 Sega a tazza bimetallica CB68 : Ø 68 mm
- 1 Albero Ref. B5547
- 1 Rondella svasatore Ref. CPL

83,16 €

COMPONENTI

	DESCRIZIONE	€
CPL	Rondella svasatore per cartongesso	61,58
B5547	Albero rigido per seghe a tazza Ø 32-250 mm	21,42
CB67	Sega a tazza bimetallica Ø 67 mm	17,16
CB68	Sega a tazza bimetallica Ø 68 mm	17,16

SEGA A TAZZA BIMETALLICA EXTRA LUNGA ACCIAIO RAPIDO HSS PER SERRATURIERI

Ref. CBX100

HSS
M3
4/6

Al

Cu - Ni - La
GHISA

PVC
100 mm
CAPACITÀ
DI TAGLIO

CBX100

	Ø mm	€
CB25X100	25	43,47
CB27X100	27	48,51
CB29X100	29	51,19
CB30X100	30	53,90
CB32X100	32	55,22
CB33X100	33	58,83
CB35X100	35	55,46
CB38X100	38	63,41
CB40X100	40	60,29

CBX100

	Ø mm	€
CB41X100	41	64,51
CB43X100	43	64,87
CB44X100	44	65,29
CB45X100	45	67,03
CB46X100	46	68,29
CB48X100	48	68,29
CB50X100	50	69,84
CB51X100	51	69,84
CB52X100	52	74,94
CB54X100	54	77,18
CB55X100	55	79,11
CB57X100	57	80,20
CB59X100	59	82,39
CB60X100	60	84,71
CB64X100	64	86,02
CB65X100	65	90,23
CB67X100	67	93,27
CB68X100	68	93,27
CB70X100	70	96,51

CBX100

	Ø mm	€
CB73X100	73	96,98
CB75X100	75	97,50
CB79X100	79	98,35
CB83X100	83	98,35
CB86X100	86	98,69
CB89X100	89	99,07
CB92X100	92	109,26
CB95X100	95	129,29
CB98X100	98	133,88
CB100X100	100	139,31
CB102X100	102	139,31
CB104X100	104	153,99
CB108X100	108	163,95
CB111X100	111	168,66
CB114X100	114	174,49
CB127X100	127	211,66
CB140X100	140	226,00
CB146X100	146	237,02
CB152X100	152	285,98

Le seghe a tazza da Ø14 a Ø30 non includono fori per l'attacco degli alberi con spine.

SEGA A TAZZA BIMETALLICA ACCIAIO RAPIDO HSSCo 4/6 DENTATURA VARIABILE

Ref. COBX100

HSSCo
8%
4/6

GHISA

Cu - Ni - La

- Maggiore durata dell'affilatura e del taglio.
- Tagli più veloci e precisi.
- Minore vibrazione e usura.
- M42. Maggiore durezza e rendimento.

100 mm
CAPACITÀ
DI TAGLIO
COBX100

	Ø mm	€
COB25X100	25	72,54
COB35X100	35	83,57
COB40X100	40	84,42
COB45X100	45	97,02
COB50X100	50	97,61
COB51X100	51	99,59

ALBERI PER SEGHE A TAZZA SERIE LUNGA

PUNTA PILOTA

DESCRIZIONE	INTERVALLO mm	€	Ø mm	Lt mm	ALBERI CORRISPONDENTI	€
B5516	14 - 30	24,33	6,35	155	B5516 / B5548	14,64
B5548	32-250	36,94				

ESPOSITORI DI SEGHE A TAZZA BIMETALLICHE



Ref. CB

HSS M3	4/6		Al	Cu-Ni-La	GHISA	PVC	
--------	-----	--	----	----------	-------	-----	--

ALBERI

ESPOSITORE DI SEGHE A TAZZA BLUE-MASTER

B5519	CB16	CB19	CB20	CB22	CB25	CB27	CB30
Ø 14-30	Ø 16	Ø 19	Ø 20	Ø 22	Ø 25	Ø 27	Ø 30
5	3	3	3	3	3	3	3
B5546	CB32	CB35	CB40	CB48	CB50	CB60	CB68
Ø32-250	Ø 32	Ø 35	Ø 40	Ø 48	Ø 50	Ø 60	Ø 68
4	3	3	2	2	2	2	2

Ref. CBEXP1

530 mm

523,76 €

↑ → 885 mm



Ref. COB

HSSCo 8%	4/6		INOX	Cu-Ni-La	GHISA
----------	-----	--	------	----------	-------

ALBERI

ESPOSITORE DI SEGHE A TAZZA HSS-Co 8% BLUEMASTER

B5519	COB16	COB19	COB20	COB22	COB25	COB27	COB30
Ø 14-30	Ø 16	Ø 19	Ø 20	Ø 22	Ø 25	Ø 27	Ø 30
5	3	3	3	3	3	3	3
B5546	COB32	COB35	COB40	COB48	COB51	COB60	COB68
Ø32-250	Ø 32	Ø 35	Ø 40	Ø 48	Ø 51	Ø 60	Ø 68
4	3	3	2	2	2	2	2

Ref. COBEXP1

530 mm

673,72 €

↑ → 885 mm



VALIGETTE DI SEGHE A TAZZA BIMETALLICHE HSS
**HSS
M3**
4/6

Al

Cu-Ni-La
GHISA

PVC
**35 mm
CAPACITÀ
DI TAGLIO**

Ref. CB



Ref. CB9576

VALIGETTA SEGHE A TAZZA PER ELETTRICISTI
**10
Pezzi**
CB9570 7 Seghe a tazza CB: Ø 16-20-25-32-40-50-68 mm

CB9576 7 Seghe a tazza CB: Ø 20-25-32-40-44-60-68 mm

Contenuto

1 Albero Ref. 5519 ◊ 9,5 Capacità 14-30

1 Albero Ref. 5546 ◊ 9,5 Capacità 32-250

1 Adattatore per gambo Ref. 5511

CB9576 96,84 €
CB9570 98,19 €

VALIGETTA SEGHE A TAZZA PER FABBRI
**9
Pezzi**
CB9571 6 Seghe a tazza CB: Ø 22-35-51-60-68-73 mm

CB9574 6 Seghe a tazza CB: Ø 22-35-50-60-68-73 mm

Contenuto

1 Albero Ref. 5519 ◊ 9,5 Capacità 14-30

1 Albero Ref. 5546 ◊ 9,5 Capacità 32-250

1 Adattatore per gambo Ref. 5511

102,21 €
VALIGETTA SEGHE A TAZZA PER IDRAULICI
**10
Pezzi**
CB9573 7 Seghe a tazza CB: Ø 20-25-30-40-44-60-68 mm

CB9575 7 Seghe a tazza CB: Ø 19-25-32-40-44-60-68 mm

Contenuto

1 Albero Ref. 5519 ◊ 9,5 Capacità 14-30

1 Albero Ref. 5546 ◊ 9,5 Capacità 32-250

1 Adattatore per gambo Ref. 5511

98,19 €
VALIGETTA PER MANUTENZIONE INDUSTRIALE
**13
Pezzi**
CB9572 10 Seghe a tazza CB: 20-22-25-32-35-40-44-60-68-76 mm

Contenuto

1 Albero Ref. 5519 ◊ 9,5 Capacità 14-30

1 Albero Ref. 5546 ◊ 9,5 Capacità 32-250

1 Adattatore per gambo Ref. 5511

132,00 €

VALIGETTE DI SEGHE A TAZZA BIMETALLICHE HSSCO 8%

HSSCo
8%

4/6

INOX



GHISA



Cu-Ni-La

- Maggiore durata dell'affilatura e del taglio.
- Tagli più veloci e precisi.
- Minore vibrazione e usura.
- M42. Maggiore durezza e rendimento.

45 mm
CAPACITÀ
DI TAGLIO



Ref. COB



Ref. COB9576



10
Pezzi

VALIGETTA SEGHE A TAZZA PER ELETTRICISTI

COB9576 7 Seghe a tazza COB: Ø 16-20-25-32-40-50-68 mm

COB9570 7 Seghe a tazza COB: Ø 20-25-32-40-44-60-68 mm

Contenuto

- 1 Albero Ref. 5519 ◊ 9,5 Capacità 14-30
- 1 Albero Ref. 5546 ◊ 9,5 Capacità 32-250
- 1 Adattatore per gambo Ref. 5511

COB9576 105,21 €

COB9570 108,00 €



VALIGETTA SEGHE A TAZZA PER IDRAULICI

10
Pezzi

COB9573 7 Seghe a tazza COB: Ø 20-25-30-40-44-60-68 mm

COB9575 7 Seghe a tazza COB: Ø 19-25-32-40-44-60-68 mm

Contenuto

- 1 Albero Ref. 5519 ◊ 9,5 Capacità 14-30
- 1 Albero Ref. 5546 ◊ 9,5 Capacità 32-250
- 1 Adattatore per gambo Ref. 5511

112,43 €

VALIGETTA SEGHE A TAZZA PER FABBRI

9
Pezzi

COB9571 6 Seghe a tazza COB: Ø 22-35-51-60-68-73 mm

COB9574 6 Seghe a tazza COB: Ø 22-35-50-60-68-73 mm

Contenuto

- 1 Albero Ref. 5519 ◊ 9,5 Capacità 14-30
- 1 Albero Ref. 5546 ◊ 9,5 Capacità 32-250
- 1 Adattatore per gambo Ref. 5511

108,00 €

VALIGETTA PER MANUTENZIONE INDUSTRIALE

13
Pezzi

COB9572 10 Seghe a tazza COB: 20-22-25-32-35-40-44-60-68-76 mm

Contenuto

- 1 Albero Ref. 5519 ◊ 9,5 Capacità 14-30
- 1 Albero Ref. 5546 ◊ 9,5 Capacità 32-250
- 1 Adattatore per gambo Ref. 5511

145,19 €



FRESA A TAZZA RIAFFILABILE HSS PER METALLI
HSS

Ref. CBR

Al

Cu - Ni - La

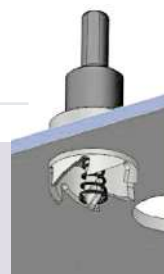
GHISA
**5 mm
CAPACITÀ
DI TAGLIO**

Serrare le ganasce del mandrino sulle tre sfaccettature dell'gamba per evitare che questo scivoli durante il lavoro.

CBR			CBR			CBR		
	Ø mm	€		Ø mm	€		Ø mm	€
CBR010	10	15,98	CBR040	40	45,66	CBR070	70	124,52
CBR011	11	16,22	CBR041	41	47,16	CBR071	71	130,92
CBR012	12	16,22	CBR042	42	48,07	CBR072	72	130,92
CBR013	13	17,57	CBR043	43	49,00	CBR073	73	130,92
CBR014	14	17,57	CBR044	44	50,18	CBR074	74	130,92
CBR015	15	17,90	CBR045	45	51,40	CBR075	75	130,92
CBR016	16	17,90	CBR046	46	52,32	CBR076	76	148,86
CBR017	17	19,97	CBR047	47	53,52	CBR077	77	148,86
CBR018	18	20,64	CBR048	48	55,04	CBR078	78	148,86
CBR019	19	21,60	CBR049	49	55,93	CBR079	79	148,86
CBR020	20	22,10	CBR050	50	57,14	CBR080	80	148,86
CBR021	21	22,75	CBR051	51	71,06	CBR081	81	169,68
CBR022	22	24,07	CBR052	52	71,06	CBR082	82	169,70
CBR023	23	25,22	CBR053	53	71,06	CBR083	83	171,77
CBR024	24	26,20	CBR054	54	71,06	CBR084	84	169,68
CBR025	25	26,82	CBR055	55	71,06	CBR085	85	169,68
CBR026	26	27,93	CBR056	56	84,66	CBR086	86	177,99
CBR027	27	28,92	CBR057	57	84,66	CBR087	87	180,04
CBR028	28	30,36	CBR058	58	84,66	CBR088	88	178,32
CBR029	29	31,72	CBR059	59	84,66	CBR089	89	178,32
CBR030	30	32,44	CBR060	60	84,66	CBR090	90	178,32
CBR031	31	35,09	CBR061	61	98,86	CBR091	91	195,88
CBR032	32	36,58	CBR062	62	98,86	CBR092	92	198,02
CBR033	33	37,82	CBR063	63	98,86	CBR093	93	195,27
CBR034	34	38,99	CBR064	64	98,86	CBR094	94	194,54
CBR035	35	39,57	CBR065	65	98,86	CBR095	95	196,60
CBR036	36	41,12	CBR066	66	124,52	CBR096	96	206,62
CBR037	37	42,32	CBR067	67	124,52	CBR097	97	208,78
CBR038	38	43,55	CBR068	68	124,52	CBR098	98	206,88
CBR039	39	44,44	CBR069	69	124,52	CBR099	99	208,99
						CBR100	100	206,95

Queste frese a tazza si somministrano sempre, senza eccezioni, con gambo a codolo cilindrico e punta pilota.



Ref. AT12



Ref. CM12

GAMBI PER FRESE A TAZZA RIAFFILABILI CON O SENZA TiN
PUNTE PILOTA

DESCRIZIONE	INTERVALLO Ø mm	€	
AT09	Codolo Ø7mm Filettatura triangolare M9x1,25+punta Ø5mm	10 - 13	15,32
AT10	Codolo Ø8mm Filettatura triangolare M10x1,25+punta Ø5mm	14 - 22	15,32
AT12	Codolo Ø9mm Filettatura triangolare M12x1,25+punta Ø6mm	23 - 40	17,15
AT16	Codolo Ø10mm Filettatura triangolare M16x1,25+punta Ø6mm	41 - 60	21,80
AT20	Codolo Ø12mm Filettatura triangolare M20x1,25+punta Ø8mm	61 - 90	24,95
AT28	Codolo Ø13mm Filettatura triangolare M28x2,00+punta Ø 8 mm	91 - 100	33,66
CM09	Cono Morse 2 - filettatura M09x1,25 + punta Ø5mm	10 - 13	39,39
CM10	Cono Morse 2 - filettatura M10x1,25 + punta Ø5mm	14 - 22	39,39
CM12	Cono Morse 2 - filettatura M12x1,25 + punta Ø6mm	23 - 40	40,26
CM16	Cono Morse 2 - filettatura M16x1,25 + punta Ø6mm	41 - 60	40,26
CM20	Cono Morse 3 - filettatura M20x1,25 + punta Ø8mm	61 - 90	58,43
CM28	Cono Morse 4 - filettatura M28x2,00 + punta Ø8mm	91 - 100	96,89

	DESCRIZIONE	INTERVALLO Ø mm	€
B5	HSS Ø 5 mm	10 - 22	6,00
B6	HSS Ø 6 mm	23 - 60	6,92
B8	HSS Ø 8 mm	61 - 100	7,65
B6TiN	HSS + TiN Ø 6 mm	23 - 60	10,05
B8TiN	HSS + TiN Ø 8 mm	61 - 100	11,11



FRESA A TAZZA RIAFFILABILE HSS + TIN PER METALLI
HSS
TiN

Ref. CBR..T

Al

Cu-Ni-La

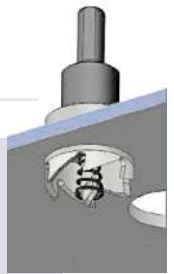
GHISA
**5 mm
CAPACITÀ
DI TAGLIO**

CBR..T		
	Ø mm	€
CBR010T	10	27,87
CBR011T	11	28,45
CBR012T	12	27,72
CBR013T	13	30,44
CBR014T	14	30,44
CBR015T	15	30,78
CBR016T	16	32,85
CBR017T	17	36,95
CBR018T	18	37,96
CBR019T	19	41,64
CBR020T	20	42,78
CBR021T	21	44,08
CBR022T	22	46,41
CBR023T	23	48,56
CBR024T	24	50,55
CBR025T	25	51,82
CBR026T	26	58,77
CBR027T	27	60,08
CBR028T	28	61,80
CBR029T	29	63,13
CBR030T	30	63,81
CBR031T	31	67,14
CBR032T	32	68,92
CBR033T	33	70,81
CBR034T	34	73,00
CBR035T	35	75,26
CBR036T	36	77,47
CBR037T	37	79,67
CBR038T	38	81,52

CBR..T		
	Ø mm	€
CBR039T	39	84,13
CBR040T	40	86,37
CBR041T	41	88,16
CBR042T	42	90,44
CBR043T	43	92,34
CBR044T	44	94,88
CBR045T	45	97,09
CBR046T	46	99,03
CBR047T	47	101,24
CBR048T	48	105,44
CBR049T	49	105,64
CBR050T	50	107,49
CBR051T	51	129,01
CBR052T	52	131,89
CBR053T	53	134,52
CBR054T	54	137,27
CBR055T	55	140,31
CBR056T	56	140,49
CBR057T	57	143,24
CBR058T	58	146,45
CBR059T	59	148,88
CBR060T	60	151,75
CBR061T	61	178,92
CBR062T	62	182,31
CBR063T	63	185,43
CBR064T	64	188,53
CBR065T	65	192,10
CBR066T	66	198,63
CBR067T	67	201,76
CBR068T	68	205,12
CBR069T	69	208,24

CBR..T		
	Ø mm	€
CBR070T	70	214,41
CBR071T	71	214,41
CBR072T	72	217,82
CBR073T	73	221,14
CBR074T	74	224,38
CBR075T	75	227,63
CBR076T	76	229,13
CBR077T	77	232,38
CBR078T	78	235,63
CBR079T	79	239,13
CBR080T	80	241,57
CBR081T	81	243,32
CBR082T	82	246,66
CBR083T	83	249,84
CBR084T	84	253,29
CBR085T	85	256,68
CBR086T	86	259,12
CBR087T	87	262,15
CBR088T	88	265,57
CBR089T	89	268,93
CBR090T	90	273,45
CBR091T	91	280,96
CBR092T	92	284,18
CBR093T	93	287,94
CBR094T	94	291,35
CBR095T	95	294,58
CBR096T	96	296,92
CBR097T	97	300,01
CBR098T	98	303,55
CBR099T	99	306,90
CBR100T	100	312,44

Queste frese a tazza si somministrano sempre, senza eccezioni, con gambo a codolo cilindrico e punta pilota.

ESPOSITORE FRESE A TAZZA RIAFFILABILI
E41P

 Contenuto:
 41 Frese a tazza Ref. CBR
 Ø 10 - Ø 50 mm

1.405,00 €

FRESA A TAZZA RIAFFILABILE HSSCo PER METALLI (SPECIALE INOX)
HSSCo
INOX

Ref. CBC

Al

Cu-Ni-La

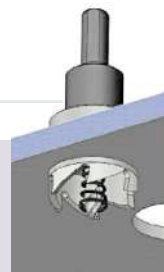
GHISA
**10 mm
CAPACITÀ
DI TAGLIO**

 Affilatura speciale
con rompitrucciolo

CBC			CBC			CBC		
	Ø mm	€		Ø mm	€		Ø mm	€
CBC012	12	27,13	CBC042	42	66,48	CBC072	72	187,12
CBC013	13	27,13	CBC043	43	67,95	CBC073	73	189,64
CBC014	14	27,13	CBC044	44	69,15	CBC074	74	192,17
CBC015	15	27,88	CBC045	45	71,09	CBC075	75	194,82
CBC016	16	28,48	CBC046	46	72,26	CBC076	76	197,80
CBC017	17	28,93	CBC047	47	74,07	CBC077	77	199,89
CBC018	18	29,69	CBC048	48	75,40	CBC078	78	202,41
CBC019	19	31,07	CBC049	49	76,87	CBC079	79	205,08
CBC020	20	32,44	CBC050	50	78,20	CBC080	80	208,04
CBC021	21	34,08	CBC051	51	110,08	CBC081	81	210,12
CBC022	22	36,05	CBC052	52	112,67	CBC082	82	212,80
CBC023	23	37,27	CBC053	53	114,26	CBC083	83	215,31
CBC024	24	38,49	CBC054	54	116,41	CBC084	84	217,83
CBC025	25	40,01	CBC055	55	119,30	CBC085	85	220,51
CBC026	26	41,52	CBC056	56	121,30	CBC086	86	223,04
CBC027	27	43,33	CBC057	57	123,31	CBC087	87	225,55
CBC028	28	44,70	CBC058	58	125,33	CBC088	88	228,23
CBC029	29	46,21	CBC059	59	127,62	CBC089	89	230,59
CBC030	30	47,72	CBC060	60	129,49	CBC090	90	233,26
CBC031	31	48,93	CBC061	61	155,22	CBC091	91	235,94
CBC032	32	50,60	CBC062	62	157,81	CBC092	92	238,31
CBC033	33	52,11	CBC063	63	159,68	CBC093	93	240,98
CBC034	34	53,77	CBC064	64	162,70	CBC094	94	243,66
CBC035	35	55,61	CBC065	65	165,16	CBC095	95	246,02
CBC036	36	56,81	CBC066	66	173,91	CBC096	96	248,56
CBC037	37	58,48	CBC067	67	175,99	CBC097	97	251,22
CBC038	38	60,46	CBC068	68	178,53	CBC098	98	253,60
CBC039	39	64,22	CBC069	69	180,29	CBC099	99	256,28
CBC040	40	65,14	CBC070	70	182,97	CBC100	100	263,98
CBC041	41	65,88	CBC071	71	184,43			

Queste frese a tazza si somministrano sempre, senza eccezioni, con gambo a codolo cilindrico e punta pilota.



Ref. HCBC1

GAMBI PER FRESE A TAZZA RIAFFILABILI CON E SENZA TiAIN

	DESCRIZIONE	INTERVALLO Ø mm	€
HCBC0	Codolo 7mm Triangular Filettatura M09x1,25+Punta Ø 5 mm	10 - 13	10,09
HCBC1	Codolo 8mm Triangular Filettatura M10x1,25+Punta Ø 5 mm	14 - 22	10,09
HCBC2	Codolo 9mm Triangular Filettatura M12x1,25+Punta Ø 6 mm	23 - 35	10,09
HCBC3	Codolo 10mm Triangular Filettatura M16x1,25+Punta Ø 6 mm	36 - 49	11,29
HCBC4	Codolo 12mm Triangular Filettatura M20x1,50+Punta Ø 8 mm	50 - 90	14,34
HCBC5	Codolo 13mm Triangular Filettatura M28x2,00+Punta Ø 8 mm	91 -100	16,43
HCBC0-CM2	Cono Morse 2 Filettatura M09x1,25 +Punta Ø 5 mm	10 - 13	25,93
HCBC1-CM2	Cono Morse 2 Filettatura M10x1,25 +Punta Ø 5 mm	14 - 22	25,93
HCBC2-CM2	Cono Morse 2 Filettatura M12x1,25 +Punta Ø 6 mm	23 - 35	26,51
HCBC2-CM3	Cono Morse 3 Filettatura M12x1,25 +Punta Ø 6 mm	23 - 35	37,98
HCBC3-CM2	Cono Morse 2 Filettatura M16x1,25 +Punta Ø 6 mm	36 - 49	37,98
HCBC3-CM3	Cono Morse 3 Filettatura M16x1,25 +Punta Ø 6 mm	36 - 49	37,98
HCBC4-CM3	Cono Morse 3 Filettatura M20x1,50 +Punta Ø 8 mm	50 - 90	38,46
HCBC4-CM4	Cono Morse 4 Filettatura M20x1,50 +Punta Ø 8 mm	50 - 90	63,80
HCBC5-CM3	Cono Morse 3 Filettatura M28x2,00 +Punta Ø 8 mm	91 -100	63,80
HCBC5-CM4	Cono Morse 4 Filettatura M28x2,00 +Punta Ø 8 mm	91 -100	63,80

PUNTE PILOTA

	DESCRIZIONE	INTERVALLO Ø mm	€
PCBC1	Guida HSSCo Ø 5 mm	10 - 22	3,95
PCBC2	Guida HSSCo Ø 6 mm	23 - 49	4,56
PCBC3	Guida HSSCo Ø 8 mm	50 -100	5,05
PCBC1TL	Guida HSSCo+TiAlN Ø5 mm	10 - 22	5,53
PCBC2TL	Guida HSSCo+TiAlN Ø6 mm	23 - 49	6,38
PCBC3TL	Guida HSSCo+TiAlN Ø8 mm	50 -100	7,06

FRESA A TAZZA RIAFFILABILE HSSCO + TIALN PER METALLI (SPECIALE INOX)
HSSCo
INOX
TiAlN

Ref. CBCTL

Al

Cu-Ni-La

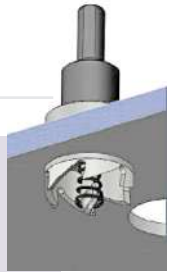
GHISA
**10 mm
CAPACITÀ
DI TAGLIO**

Frese e seghe a tazza

Rosa



CBCTL			CBCTL			CBCTL		
	Ø mm	€		Ø mm	€		Ø mm	€
CBC012TL	12	38,91	CBC042TL	42	104,64	CBC072TL	72	309,00
CBC013TL	13	38,91	CBC043TL	43	107,16	CBC073TL	73	317,67
CBC014TL	14	38,91	CBC044TL	44	109,36	CBC074TL	74	326,29
CBC015TL	15	40,00	CBC045TL	45	112,30	CBC075TL	75	335,33
CBC016TL	16	43,29	CBC046TL	46	114,40	CBC076TL	76	339,47
CBC017TL	17	45,14	CBC047TL	47	117,14	CBC077TL	77	340,26
CBC018TL	18	45,86	CBC048TL	48	120,69	CBC078TL	78	341,51
CBC019TL	19	49,82	CBC049TL	49	121,42	CBC079TL	79	354,68
CBC020TL	20	51,54	CBC050TL	50	123,10	CBC080TL	80	359,87
CBC021TL	21	53,69	CBC051TL	51	167,79	CBC081TL	81	362,49
CBC022TL	22	57,01	CBC052TL	52	175,21	CBC082TL	82	364,43
CBC023TL	23	58,83	CBC053TL	53	180,89	CBC083TL	83	368,96
CBC024TL	24	60,40	CBC054TL	54	187,75	CBC084TL	84	374,82
CBC025TL	25	62,62	CBC055TL	55	196,31	CBC085TL	85	376,26
CBC026TL	26	70,07	CBC056TL	56	204,94	CBC086TL	86	378,69
CBC027TL	27	72,48	CBC057TL	57	212,00	CBC087TL	87	379,14
CBC028TL	28	73,77	CBC058TL	58	219,81	CBC088TL	88	391,82
CBC029TL	29	75,00	CBC059TL	59	227,21	CBC089TL	89	396,49
CBC030TL	30	76,17	CBC060TL	60	234,61	CBC090TL	90	403,16
CBC031TL	31	77,67	CBC061TL	61	235,87	CBC091TL	91	407,13
CBC032TL	32	79,77	CBC062TL	62	243,95	CBC092TL	92	411,41
CBC033TL	33	81,70	CBC063TL	63	250,67	CBC093TL	93	418,26
CBC034TL	34	84,29	CBC064TL	64	259,34	CBC094TL	94	420,49
CBC035TL	35	88,07	CBC065TL	65	267,81	CBC095TL	95	424,77
CBC036TL	36	89,57	CBC066TL	66	276,09	CBC096TL	96	425,42
CBC037TL	37	92,08	CBC067TL	67	283,47	CBC097TL	97	425,72
CBC038TL	38	94,75	CBC068TL	68	292,04	CBC098TL	98	438,14
CBC039TL	39	101,71	CBC069TL	69	299,16	CBC099TL	99	443,09
CBC040TL	40	103,07	CBC070TL	70	301,00	CBC100TL	100	458,98
CBC041TL	41	104,47	CBC071TL	71	303,62			

Queste frese a tazza si somministrano sempre, senza eccezioni, con gambi a codolo cilindrico e punta pilota.

ESPOSITORE FRESE A TAZZA RIAFFILABILI
CBC41P

 Contenuto: 39 Frese a tazza Ref. CBC
 Ø 12 - Ø 50 mm

1.952,74 €



* Set ed espositori su richiesta.

FRESA A TAZZA RIAFFILABILE HSS PER METALLI SOTTILI
HSS

Ref. CCF

Al

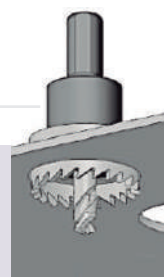
Cu - Ni - La

GHISA
2 mm
CAPACITÀ
DI TAGLIO

CCF			CCF		
	Ø mm	€		Ø mm	€
CCF12	12	20,68	CCF31	31	44,76
CCF13	13	22,42	CCF32	32	46,66
CCF14	14	22,42	CCF33	33	48,24
CCF15	15	22,84	CCF34	34	49,75
CCF16	16	22,84	CCF35	35	50,48
CCF17	17	25,47	CCF36	36	52,45
CCF18	18	26,33	CCF37	37	53,99
CCF19	19	27,56	CCF38	38	55,55
CCF20	20	28,19	CCF39	39	56,68
CCF21	21	29,00	CCF40	40	58,25
CCF22	22	30,71	CCF41	41	60,15
CCF23	23	32,18	CCF42	42	61,32
CCF24	24	33,42	CCF43	43	62,49
CCF25	25	34,20	CCF44	44	63,99
CCF26	26	35,62	CCF45	45	65,57
CCF27	27	36,90	CCF46	46	66,72
CCF28	28	38,72	CCF47	47	68,27
CCF29	29	40,45	CCF48	48	70,19
CCF30	30	41,38	CCF49	49	71,34

Queste frese a tazza si somministrano sempre, senza eccezioni, con gambo a codolo cilindrico e punta pilota.



Ref. AT12



Ref. CM12

GAMBI PER FRESE A TAZZA RIAFFILABILI

	DESCRIZIONE	INTERVALLO Ø mm	€
AT09	Codolo Ø7mm Triangular filettatura M9x1,25+punta Ø5mm	10 - 13	15,32
AT10	Codolo Ø8mm Triangular filettatura M10x1,25+punta Ø5mm	14 - 22	15,32
AT12	Codolo Ø9mm Triangular filettatura M12x1,25+punta Ø6mm	23 - 40	17,15
AT16	Codolo Ø10mm Triangular filettatura M16x1,25+punta Ø6mm	41 - 60	21,80
CM09	Cono Morse 2 - filettatura M09x1,25 + punta Ø5mm	10 - 13	39,39
CM10	Cono Morse 2 - filettatura M10x1,25 + punta Ø5mm	14 - 22	39,39
CM12	Cono Morse 2 - filettatura M12x1,25 + punta Ø6mm	23 - 40	40,26
CM16	Cono Morse 2 - filettatura M16x1,25 + punta Ø6mm	41 - 60	40,26

PUNTE PILOTA

	DESCRIZIONE	INTERVALLO Ø mm	€
B5	HSS Ø 5 mm	10 - 22	6,00
B6	HSS Ø 6 mm	23 - 60	6,92
B6TiN	HSS + TiN Ø 6 mm	23 - 60	10,05



SEGA A TAZZA CON DENTI IN METALLO DURO RAZORBACK

Ref. CBMD

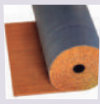

35 mm
CAPACITÀ
DI TAGLIO

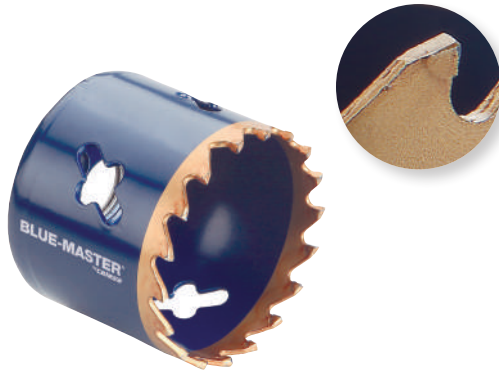

- Denti in metallo duro.
- Speciale per lavori intensivi in acciaio inossidabile.
- Resistono all'abrasione meglio delle seghe a tazza bimetalliche.
- Trapano dove non vanno quelli seghe a tazza bimetalliche.
- Aumenta e migliora la produttività nel trapanato.
- Si consiglia di non trapanare materiali metallici superiori a 3 mm.

Ø mm			Blister	
	Ref.	€	Ref.	€
19	CBMD19	17,70	CBMD19B	17,70
22	CBMD22	20,51	CBMD22B	20,51
25	CBMD25	23,29	CBMD25B	23,29
30	CBMD30	27,95	CBMD30B	27,95
32	CBMD32	29,72	CBMD32B	29,72
35	CBMD35	32,62	CBMD35B	32,62
37	CBMD37	34,49	CBMD37B	34,49
38	CBMD38	35,43	CBMD38B	35,43
44	CBMD44	40,99	CBMD44B	40,99
48	CBMD48	44,75	CBMD48B	44,75
51	CBMD51	47,53	CBMD51B	47,53
54	CBMD54	50,33	CBMD54B	50,33
57	CBMD57	53,04	CBMD57B	53,04
60	CBMD60	55,91	CBMD60B	55,91
64	CBMD64	59,64	CBMD64B	59,64
67	CBMD67	62,43	CBMD67B	62,43
70	CBMD70	65,24	CBMD70B	65,24
76	CBMD76	70,82	CBMD76B	70,82
83	CBMD83	77,36	CBMD83B	77,36
86	CBMD86	80,17		
89	CBMD89	82,95		
95	CBMD95	88,56		
102	CBMD102	95,07		
108	CBMD108	100,66		
111	CBMD111	103,46		
114	CBMD114	106,26		
121	CBMD121	112,78		
127	CBMD127	118,37		
140	CBMD140	130,49		
146	CBMD146	136,08		
152	CBMD152	141,67		

• Gli alberi per la CBMD sono gli stessi di quelli per le seghe a tazza CB e COB.



Ref. CBMD

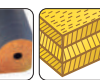

ALBERI

ESPOSITORE DI SEGHE A TAZZA HSS-Co 8% BLUEMASTER

B5519	CBMD19	CBMD22	CBMD25	CBMD30	CBMD32	CBMD35	CBMD38
Ø 14-30	Ø 19	Ø 22	Ø 25	Ø 30	Ø 32	Ø 35	Ø 38
4	2	2	2	2	2	2	2
B5546	CBMD44	CBMD48	CBMD51	CBMD54	CBMD60	CBMD67	CBMD70
Ø 32-250	Ø 44	Ø 48	Ø 51	Ø 54	Ø 60	Ø 67	Ø 70
4	2	2	2	2	2	2	2

Ref. CBMDXP1

1.255,50 €

530 mm

885 mm

FRESA A TAZZA IN METALLO DURO CON PUNZONE RETRATTILE PER LAVORO SERIALE

Ref. CP

MD



Al



Cu-Ni-La

GHISA

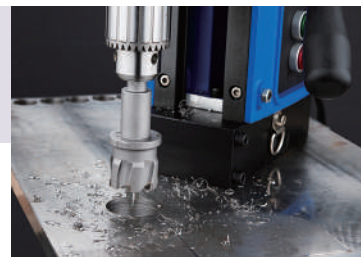
12 mm
CAPACITÀ
DI TAGLIO

CP	Ø mm	€
		CP1500
CP1600	16	105,75
CP1700	17	105,75
CP1800	18	105,75
CP1900	19	105,75
CP2000	20	105,75
CP2100	21	105,75
CP2200	22	117,14
CP2300	23	117,14
CP2400	24	117,14
CP2500	25	125,45
CP2600	26	125,45
CP2700	27	125,45
CP2800	28	125,45
CP2900	29	125,45
CP3000	30	125,45
CP3100	31	148,25
CP3200	32	148,25
CP3300	33	148,25
CP3400	34	148,25
CP3500	35	148,25

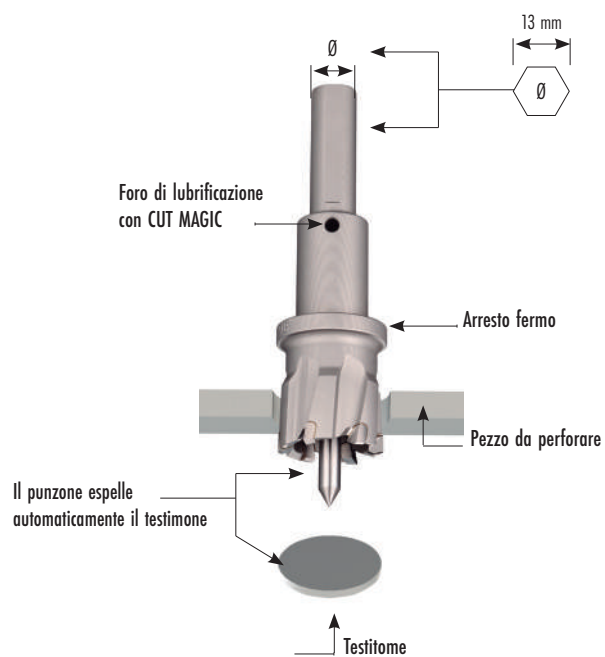
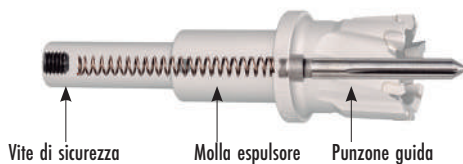
PUNZONE DI RICAMBIO

PCP01

	Ø mm	€
PCP01	Ø 6 x 53 mm	17,79

SUPER FRESE A TAZZA IN METALLO DURO PER TUTTI I TIPI DI MATERIALI (SPECIALE INOX)

MD



INOX

Al



Cu-Ni-La

GHISA

* Corpo monoblocco

**12 mm
CAPACITÀ
DI TAGLIO**

CX18-CX40: Ø10 mm
CX41-CX100: Ø13 mm



**25 mm
CAPACITÀ
DI TAGLIO**

Ø13 mm

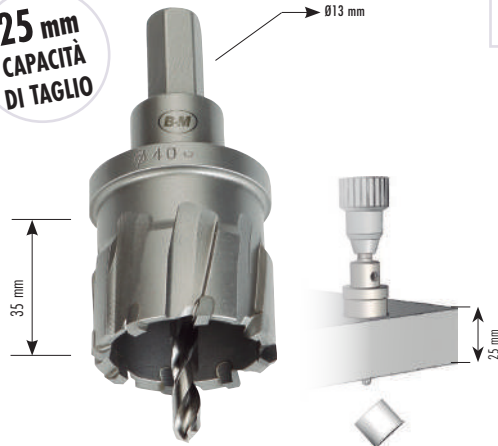

**GEOMETRIA
SPECIFICA
INOX**

Ref. CX

Ref. CXL

	Ø mm	Z	€
CX18	18	4	63,65
CX19	19	4	63,65
CX20	20	6	63,65
CX21	21	6	63,65
CX22	22	6	63,65
CX23	23	6	63,65
CX24	24	6	63,65
CX25	25	6	63,65
CX26	26	6	73,76
CX27	27	6	73,76
CX28	28	6	73,76
CX29	29	6	73,76
CX30	30	6	73,76
CX31	31	6	85,39
CX32	32	6	85,39
CX33	33	6	85,39
CX34	34	8	85,39
CX35	35	8	85,39
CX36	36	8	93,17
CX38	38	8	93,17
CX39	39	8	93,17
CX40	40	8	93,17
CX41	41	8	107,73
CX42	42	8	107,73
CX43	43	8	107,73
CX44	44	10	107,73
CX45	45	10	107,73
CX46	46	10	123,74

	Ø mm	Z	€
CX48	48	10	123,74
CX49	49	10	123,74
CX50	50	10	123,74
CX51	51	10	171,98
CX52	52	10	171,98
CX53	53	10	171,98
CX55	55	10	171,98
CX56	56	12	199,26
CX57	57	12	199,26
CX58	58	12	199,26
CX59	59	12	199,26
CX60	60	12	199,26
CX61	61	12	233,85
CX62	62	12	233,85
CX63	63	12	233,85
CX64	64	12	233,85
CX65	65	12	233,85
CX66	66	12	266,08
CX67	67	12	266,08
CX68	68	12	266,08
CX69	69	12	266,08
CX70	70	12	266,08
CX75	75	14	300,79
CX80	80	14	313,06
CX85	85	14	341,26
CX90	90	16	349,72
CX95	95	16	367,28
CX100	100	16	380,36

	Ø mm	Z	€
CXL18	18	6	85,94
CXL19	19	6	85,94
CXL20	20	6	85,94
CXL21	21	6	85,94
CXL22	22	6	85,94
CXL23	23	6	85,94
CXL24	24	6	85,94
CXL25	25	6	85,94
CXL26	26	6	99,58
CXL27	27	6	99,58
CXL28	28	6	99,58
CXL29	29	6	99,58
CXL30	30	6	99,58
CXL31	31	6	115,28
CXL32	32	6	115,28
CXL33	33	6	115,28
CXL34	34	6	115,28
CXL35	35	6	115,28
CXL36	36	6	125,79
CXL38	38	6	125,79
CXL39	39	6	125,79
CXL40	40	8	125,79
CXL41	41	8	145,44
CXL42	42	8	145,44
CXL43	43	8	145,44
CXL44	44	8	145,44
CXL45	45	8	145,44
CXL46	46	8	167,06

	Ø mm	Z	€
CXL48	48	8	167,06
CXL49	49	8	167,06
CXL50	50	8	167,06
CXL51	51	8	232,18
CXL52	52	8	232,18
CXL53	53	8	232,18
CXL55	55	8	232,18
CXL56	56	8	269,01
CXL57	57	8	269,01
CXL58	58	8	269,01
CXL59	59	8	269,01
CXL60	60	8	269,01
CXL61	61	10	315,70
CXL62	62	10	315,70
CXL63	63	10	315,70
CXL64	64	10	315,70
CXL65	65	10	315,70

PUNTA PILOTA CX



	Ø mm	€
BRCX06X70	Ø 6 x 70 mm	13,89

PUNTA PILOTA CXL



	Ø mm	€
BRCXL06X75	Ø 6 x 75 mm	16,16

SUPER FRESE A TAZZA IN METALLO DURO PER TUBI E LAMIERE (SPECIALE INOX)

 Ref. X
 Ref. XT

MD



INOX

Al



Cu - Ni - La

GHISA

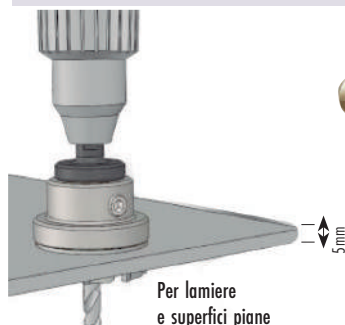
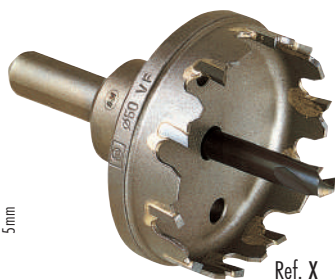
5 mm
CAPACITÀ
DI TAGLIO

 Per lamiere
 e superfici piane

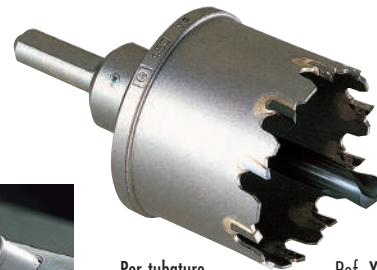
Ref. X

 Per tubature
 e superfici curve

Ref. XT

X

X

	Ø mm	Z	€		Ø mm	Z	€
X14	14,0	3	79,85	X55	55,0	12	184,09
X14,5	14,5	3	79,85	X56	56,0	12	213,28
X15	15,0	3	79,85	X57	57,0	12	213,28
X16	16,0	3	79,85	X58	58,0	12	213,28
X17	17,0	4	79,85	X59	59,0	12	213,28
X18	18,0	4	79,85	X60	60,0	12	213,28
X19	19,0	4	79,85	X61	61,0	12	250,31
X20	20,0	4	79,85	X62	62,0	12	250,31
X21	21,0	4	79,85	X63	63,0	12	250,31
X22	22,0	4	79,85	X64	64,0	12	250,31
X23	23,0	4	79,85	X65	65,0	12	250,31
X24	24,0	4	79,85	X66	66,0	12	271,23
X25	25,0	4	79,85	X67	67,0	12	271,23
X26	26,0	4	92,52	X68	68,0	12	271,23
X27	27,0	4	92,52	X69	69,0	12	271,23
X28	28,0	6	92,52	X70	70,0	12	271,23
X29	29,0	6	92,52	X71	71,0	14	293,13
X30	30,0	6	92,52	X72	72,0	14	293,13
X31	31,0	6	107,12	X73	73,0	14	293,13
X32	32,0	6	107,12	X74	74,0	14	293,13
X33	33,0	6	107,12	X75	75,0	14	293,13
X34	34,0	6	107,12	X76	76,0	14	315,08
X35	35,0	8	107,12	X77	77,0	14	315,08
X36	36,0	8	124,66	X78	78,0	14	315,08
X37	37,0	8	124,66	X79	79,0	14	315,08
X38	38,0	8	124,66	X80	80,0	14	315,08
X39	39,0	8	124,66	X81	81,0	14	348,66
X40	40,0	8	124,66	X82	82,0	16	348,66
X41	41,0	8	144,15	X83	83,0	16	348,66
X42	42,0	10	144,15	X84	84,0	16	348,66
X43	43,0	10	144,15	X85	85,0	16	348,66
X44	44,0	10	144,15	X89	89,0	16	382,75
X45	45,0	10	144,15	X90	90,0	16	382,75
X46	46,0	10	165,56	X91	91,0	16	398,34
X47	47,0	10	165,56	X92	92,0	16	398,34
X48	48,0	10	165,56	X95	95,0	16	398,34
X49	49,0	10	165,56	X100	100,0	18	424,62
X50	50,0	10	165,56	X102	102,0	18	468,45
X51	51,0	10	184,09	X105	105,0	18	468,45
X52	52,0	10	184,09	X110	110,0	20	516,18
X53	53,0	10	184,09	X115	115,0	20	567,81
X54	54,0	10	184,09	X120	120,0	20	625,74

XT

XT

	Ø mm	Z	€		Ø mm	Z	€
XT16	16,0	3	119,88	XT62	62,0	12	409,05
XT17	17,0	4	119,88	XT65	65,0	12	409,05
XT18	18,0	4	119,88	XT70	70,0	12	428,52
XT19	19,0	4	119,88	XT75	75,0	14	463,58
XT20	20,0	4	119,88	XT80	80,0	14	498,66
XT21	21,0	4	119,88	XT85	85,0	16	551,22
XT22	22,0	4	119,88	XT90	90,0	16	603,82
XT23	23,0	4	119,88	XT95	95,0	16	633,05
XT24	24,0	4	119,88	XT100	100,0	18	672,01
XT25	25,0	4	119,88	XT105	105,0	18	740,18
XT26	26,0	4	138,93	XT110	110,0	20	818,08
XT27	27,0	4	138,93	XT115	115,0	20	899,92
XT28	28,0	6	138,93	XT120	120,0	20	993,41
XT29	29,0	6	138,93	XT130	130,0	20	1.561,94
XT30	30,0	6	138,93	XT140	140,0	25	1.835,16
XT31	31,0	6	160,78	XT150	150,0	28	2.226,97
XT32	32,0	6	160,78				
XT33	33,0	6	160,78				
XT34	34,0	6	160,78				
XT35	35,0	8	160,78				
XT36	36,0	8	187,00				
XT37	37,0	8	187,00				
XT38	38,0	8	187,00				
XT39	39,0	8	187,00				
XT40	40,0	8	187,00				
XT41	41,0	8	216,22				
XT42	42,0	10	216,22				
XT43	43,0	10	216,22				
XT44	44,0	10	216,22				
XT45	45,0	10	216,22				
XT46	46,0	10	245,44				
XT47	47,0	10	245,44				
XT48	48,0	10	245,44				
XT49	49,0	10	245,44				
XT50	50,0	10	245,44				
XT51	51,0	10	276,34				
XT52	52,0	10	276,34				
XT53	53,0	10	276,34				
XT54	54,0	10	276,34				
XT55	55,0	12	276,34				
XT60	60,0	12	409,05				
XT61	61,0	12	409,05				

PUNTE PILOTA HSS-Co PER METALLO



	INTERVALLO Ø mm	€		INTERVALLO Ø mm	€
X6	14 - 59	13,67	XT8	23 - 59	24,94
X8	60 - 120	16,11	XT8L	60 - 100	32,16
XT6	6 - 22	18,66	XT8XL	105 - 120	36,32

TABELLA DI SELEZIONE PER SUPER FRESE A TAZZA MULTIFUNZIONE IN METALLO DURO



5 mm
CAPACITÀ
DI TAGLIO

Ref. C50X



50 mm
CAPACITÀ
DI TAGLIO

Ref. CXX

	<p>9 mm</p>	<p>Ø14-60 Ref. BCX1</p>	+	<p>Ref. C50X</p>	+	<p>Ref. CXX2</p>	=	
	<p>11 mm</p>	<p>Ø14-100 Ref. BCX2</p>						
	<p>9 mm</p>	<p>Ø14-60 Ref. BCX1</p>						
	<p>11 mm</p>	<p>Ø14-100 Ref. BCX2</p>						
	<p>FEIN 18-00 mm</p> <p>Ref. CXX18W</p>	+	<p>Ref. C50X</p>	+	<p>Ref. P750CA</p>	=		
	<p>DOBLE WELDON 19-05 mm</p> <p>Ref. CXXW</p>							<p>Ref. CXX</p>
	<p>Ø14-100 Ref. CXXCM2</p>	+	<p>Ref. C50X</p>	+	<p>Ref. CXX2</p>	=		
	<p>Ø14-150 Ref. CXXCM3</p>							<p>Ref. CXX</p>

SUPER FRESA A TAZZA MULTIFUNZIONE IN METALLO DURO PER PIENI
MD

Ref. CXX

Al

Cu - Ni - La

GHISA
50 mm
CAPACITÀ
DI TAGLIO

GAMBI PER FRESE A TAZZA MULTIFUNZIONE CODOLO ESAGONALE

	DESCRIZIONE	INTERVALLO Ø mm	€
BCX1	Codolo esagonale 9 mm	14 - 60	21,12
BCX2	Codolo esagonale 11 mm	14 - 100	21,12

GAMBI PER FRESE A TAZZA MULTIFUNZIONE CODOLO CONICO

	DESCRIZIONE	INTERVALLO Ø mm	€
CXXCM2	Codolo Cono Morse 2	14 - 100	38,26
CXXCM3	Codolo Cono Morse 3	14 - 150	40,71

PUNTE PILOTA

	DESCRIZIONE	CXX	€
CXX1	Ø 6 x 90L mm		8,15

	Ø mm	€	CXX	Ø mm	€
CXX14	14	133,05	CXX45	45	225,20
CXX15	15	133,05	CXX46	46	258,64
CXX16	16	133,05	CXX47	47	258,64
CXX17	17	133,05	CXX48	48	258,64
CXX18	18	133,05	CXX49	49	258,64
CXX19	19	133,05	CXX50	50	258,64
CXX20	20	133,05	CXX51	51	287,58
CXX21	21	133,05	CXX52	52	287,58
CXX22	22	133,05	CXX53	53	287,58
CXX23	23	133,05	CXX54	54	287,58
CXX24	24	133,05	CXX55	55	287,58
CXX25	25	133,05	CXX56	56	333,20
CXX26	26	154,19	CXX57	57	333,20
CXX27	27	154,19	CXX58	58	333,20
CXX28	28	154,19	CXX59	59	333,20
CXX29	29	154,19	CXX60	60	333,20
CXX30	30	154,19	CXX61	61	391,04
CXX31	31	178,50	CXX62	62	391,04
CXX32	32	178,50	CXX63	63	391,04
CXX33	33	178,50	CXX64	64	391,04
CXX34	34	178,50	CXX65	65	391,04
CXX35	35	178,50	CXX66	66	459,41
CXX36	36	194,76	CXX67	67	459,41
CXX37	37	194,77	CXX68	68	459,41
CXX38	38	194,76	CXX69	69	459,41
CXX39	39	194,76	CXX70	70	459,41
CXX40	40	194,76	CXX75	75	476,69
CXX41	41	225,20	CXX80	80	515,68
CXX42	42	225,20	CXX85	85	552,41
CXX43	43	225,20	CXX90	90	594,04
CXX44	44	225,20	CXX100	100	638,11

ADATTATORI SUPPORTO ELETTROMAGNETICO

Tipo Fein



Tipo Weldon

	CXX	€
CXX18W	Codolo Fein 18,00 mm	38,26
CXXW	Codolo Weldon 19,05 mm	38,26

PUNZONE

	P	€
P750CA	Ø 6.35 mm x 100 mm	17,39

SUPER FRESA A TAZZA MULTIFUNZIONE IN METALLO DURO PER TUBI E LAMIERE

MD

Ref. C50X



**5 mm
CAPACITÀ
DI TAGLIO**



GAMBI PER FRESE A TAZZA MULTIFUNZIONE CODOLO ESAGONALE



	DESCRIZIONE	INTERVALLO Ø mm	€
BCX1	Codolo esagonale 9 mm	14 - 60	21,12
BCX2	Codolo esagonale 11 mm	14 - 100	21,12

GAMBI PER FRESE A TAZZA MULTIFUNZIONE CODOLO CONICO



	DESCRIZIONE	INTERVALLO Ø mm	€
CXXCM2	Codolo Cono Morse 2	14 - 100	38,26
CXXCM3	Codolo Cono Morse 3	14 - 150	40,71

PUNTE PILOTA



	DESCRIZIONE	CXX	€
CXX2	Ø 6 x 75L mm		7,65

ADATTATORI SUPPORTO ELETTROMAGNETICO



Tipo Fein



Tipo Weldon

		CXX	€
CXX18W	Codolo Fein 18,00mm		38,26
CXXW	Codolo Weldon 19,05mm		38,26

PUNZONE



	DESCRIZIONE	P	€
P750CA	Ø 6.35mm x 100mm		17,39

**FRESA A TAZZA PER LAVORI PESANTI CON DENTI IN METALLO DURO E CAMBIO POLY-CLICK COMPATIBILE
 CON CONO MORSE N°4 E N°5, CON REFRIGERAZIONE INTERNA**

Ref. MBM

MD



INOX

Al

GHISA

50 mm
 CAPACITÀ
 DI TAGLIO

- Utilizzare in ogni caso la refrigerazione interna.
- Non consumare la vita dei denti del tutto, per permettere successive riaffilature.
- L'accostamento della fresa al materiale deve essere progressivo e delicato in modo da evitare la rottura dei denti per urto.



	MBM		
	Ø mm	Z	€
MBM35	35,0	4	64,93*
MBM36	36,0	4	64,93*
MBM38	38,0	4	64,93*
MBM40	40,0	6	76,52*
MBM42	42,0	6	76,52*
MBM43	43,0	6	76,52*
MBM44	44,0	6	76,52*
MBM45	45,0	6	84,39*
MBM48	48,0	6	84,39*
MBM49	49,0	6	84,39*
MBM50	50,0	6	94,60*
MBM51	51,0	6	94,60*
MBM52	52,0	6	94,60*
MBM53	53,0	6	94,60*
MBM54	54,0	6	94,60*
MBM56	56,0	6	104,80*
MBM58	58,0	6	104,80*
MBM60	60,0	6	122,42*
MBM61	61,0	6	122,42*
MBM62	62,0	6	122,42*

	MBM		
	Ø mm	Z	€
MBM65	65,0	6	122,42*
MBM66	66,0	6	132,62*
MBM68	68,0	6	132,62*
MBM70	70,0	6	132,62*
MBM75	75,0	6	142,83*
MBM77	77,0	6	153,03*
MBM78	78,0	6	153,03*
MBM80	80,0	6	153,03*
MBM82	82,0	6	240,47*
MBM85	85,0	6	240,47*
MBM90	90,0	6	262,33*
MBM95	95,0	6	282,21*
MBM110	110,0	6	244,85*
MBM115	115,0	6	268,03*
MBM125	125,0	6	340,84*
MBM130	130,0	6	384,89*
MBM140	140,0	6	459,08*

*Fino ad esaurimento scorte.

GAMBI CODOLO CONICO CON PUNZONE

	DESCRIZIONE	€
500MT4	Alberi Cono Morse 4	192,91*
500MT5	Alberi Cono Morse 5	199,40*

PUNZONE PER LAMIERE SOTTILI FINO A 4 mm

Ref. PC

**FINO A
4 mm
LAMIERE SOTTILI**



Modalità d'uso:

- Realizzare un preforo con la nostra punta a svasare Ref. AV30.
- Introdurre la vite Ref. PCM nel foro realizzato.
- Dal lato opposto avvitare la lama di taglio Ref. PCC sulla vite.
- Stringere finchè la lama di taglio Ref. PCC seziona la lamiera contro il cuscinetto Ref. PBC.
- Utilizzare CUT MAGIC per lavorare con la perforatrice Ref. PC.



METRICA VITE	SPESSORE MASSIMO LAMIERA DA PERFORARE			
	ACCIAIO NORMALE	INOX	NON FERROSI	PLASTICHE
M10x1.0	2.00 mm	1.00 mm	4.00 mm	4.00 mm
M12x1.5	3.00 mm	1.50 mm	4.00 mm	4.00 mm
M16x1.5	3.00 mm	1.50 mm	4.00 mm	4.00 mm

		PC
	Ø	€
PC1270	12,70 PG7	35,98
PC1400	14,00	36,54
PC1520	15,20 PG9	36,89
PC1600	16,00	36,89
PC1650	16,50	37,71
PC1700	17,00	38,24
PC1800	18,00	38,24
PC1860	18,60 PG11	40,34
PC1900	19,00	40,34
PC2000	20,00	41,28
PC2040	20,40 PG13,5	41,28
PC2100	21,00	42,38
PC2200	22,00	44,07
PC2250	22,50 PG16	44,07
PC2300	23,00	45,63
PC2400	24,00	45,63
PC2500	25,00	48,46
PC2540	25,40	48,46

		PC
	Ø	€
PC2600	26,00	50,05
PC2700	27,00	50,05
PC2830	28,30 PG21	50,05
PC2900	29,00	53,75
PC3000	30,00	53,75
PC3100	31,00	53,75
PC3200	32,00	54,48
PC3250	32,50	61,83
PC3300	33,00	61,83
PC3400	34,00	61,83
PC3500	35,00	61,83
PC3600	36,00	66,74
PC3700	37,00 PG29	66,74
PC3800	38,00	66,74
PC3900	39,00	84,70
PC4000	40,00	84,70
PC4050	40,50	85,15
PC4100	41,00	85,15

		PC
	Ø	€
PC4200	42,00	92,55
PC4300	43,00	92,55
PC4400	44,00	95,34
PC4500	45,00	100,65
PC4600	46,00	100,65
PC4700	47,00 PG36	102,30
PC4800	48,00	110,39
PC4900	49,00	110,39
PC5000	50,00	113,79
PC5050	50,50	121,05
PC5100	51,00	121,05
PC5200	52,00	124,58
PC5300	53,00	124,58
PC5400	54,00 PG42	131,07
PC5500	55,00	131,07
PC6000	60,00 PG48	162,12
PC6350	63,50	186,34

VITE DI TRAZIONE E RONDELLA



		PCM
	DESCRIZIONE	€
PCM10	(Filettatura M10 x 1,00) Punzoni da Ø 12,70 - 25,40 mm	5,11
PCM12	(Filettatura M12 x 1,50) Punzoni da Ø 26 - 41 mm	5,11
PCM16	(Filettatura M16 x 1,50) Punzoni da Ø 42 - 63,50 mm	5,82

CUSCINETTO A SFERA



PBC

Consulti il prezzo per ogni diametro



LAMA DI TAGLIO



PCC

Consulti il prezzo per ogni diametro







CONDIZIONI DI TAGLIO PER FRESE E SEGHE A TAZZA IN HSS E HHScO
TABELLA DI AVANZAMENTO

mm/GIRO	 	  50 HRC	 INOX	 GHISA	 Al
CB - COB - CBR	0,053	-	0,05	0,075	0,12
CBC - CCF	0,063	-	0,055	0,085	0,15

SCELTA DELLE R.P.M. PER FRESE E SEGHE A TAZZA CB - COB - CBR - CBC - CCF

Vc (m/min)	SCELTA DIAMETRO (Ø mm)													
	10	15	20	25	30	35	40	50	60	70	80	90	100	
100	3183	2122	1952	1273	1061	909	796	637	531	455	398	354	318	
95	3024	2016	1512	1512	1008	864	756	605	504	432	378	336	302	
90	2865	1910	1432	1432	955	819	716	573	477	409	358	318	286	
85	2706	1804	1353	1353	902	773	676	541	451	387	338	301	271	
80	2547	1698	1273	1276	849	728	637	509	424	364	318	283	255	
75	2387	1592	1194	1194	796	682	597	477	398	341	298	265	239	
70	2228	1485	1114	1114	743	637	557	446	371	318	279	248	223	
65	2069	1379	1035	1035	690	591	517	414	345	296	259	230	207	
60	1910	1273	955	922	637	546	477	382	318	273	239	212	191	
55	1751	1167	875	875	584	500	438	350	292	250	219	195	175	
50	1592	1061	796	796	531	455	398	318	265	227	199	177	159	
45	1432	955	716	716	477	409	658	286	239	205	179	159	143	
40	1273	849	637	637	424	364	618	255	212	192	159	141	127	
35	1114	743	557	557	371	318	279	223	186	159	139	124	111	
30	955	637	477	477	318	273	239	191	159	136	119	106	95	
25	796	531	398	398	265	227	199	159	133	114	99	88	80	
20	637	424	318	318	212	182	159	127	106	91	80	71	64	
15	477	318	239	239	159	136	119	95	80	68	60	53	48	
10	318	212	159	159	106	91	80	64	53	45	40	35	32	

CONDIZIONI DI TAGLIO PER FRESE A TAZZA CON DENTI IN METALLO DURO
TABELLA DI AVANZAMENTO

mm/GIRO	 	  50 HRC	 INOX	 GHISA	 Al	 Ni
LEGGERE: CX - CXL - X - XT	0,035	0,025	0,02	0,040	0,075	0,020
C50X - CXX - MBM - CBMD - CP	0,10	0,075	0,095	0,15	0,22	0,07

SCELTA DELLE R.P.M. PER FRESE A TAZZA CX - CXL - X - XT - C50X - CXX - MBM - CBMD - CP

Vc (m/min)	SCELTA DIAMETRO (Ø mm)													
	10	15	20	25	30	35	40	50	60	70	80	90	100	
100	3183	2122	1952	1273	1061	909	796	637	531	455	398	354	318	
95	3024	2016	1512	1512	1008	864	756	605	504	432	378	336	302	
90	2865	1910	1432	1432	955	819	716	573	477	409	358	318	286	
85	2706	1804	1353	1353	902	773	676	541	451	387	338	301	271	
80	2547	1698	1273	1276	849	728	637	509	424	364	318	283	255	
75	2387	1592	1194	1194	796	682	597	477	398	341	298	265	239	
70	2228	1485	1114	1114	743	637	557	446	371	318	279	248	223	
65	2069	1379	1035	1035	690	591	517	414	345	296	259	230	207	
60	1910	1273	955	922	637	546	477	382	318	273	239	212	191	
55	1751	1167	875	875	584	500	438	350	292	250	219	195	175	
50	1592	1061	796	796	531	455	398	318	265	227	199	177	159	
45	1432	955	716	716	477	409	658	286	239	205	179	159	143	
40	1273	849	637	637	424	364	618	255	212	192	159	141	127	
35	1114	743	557	557	371	318	279	223	186	159	139	124	111	
30	955	637	477	477	318	273	239	191	159	136	119	106	95	
25	796	531	398	398	265	227	199	159	133	114	99	88	80	
20	637	424	318	318	212	182	159	127	106	91	80	71	64	
15	477	318	239	239	159	136	119	95	80	68	60	53	48	
10	318	212	159	159	106	91	80	64	53	45	40	35	32	