

BLUE-MASTER[®]
by *celesa*



SERRAS CRANEANAS
E FRESAS

GUIA PARA A SELEÇÃO DE FRESAS / SERRAS CRANEANAS
FRESAS / SERRAS CRANEANAS PARA METAL

REFERÊNCIA	Tipo e profundidade de corte	Recomendação e Aplicação Características e Gama	Pag.
CB	BI-METAL HSS 35 mm	 Gama de Ø14/250mm	552
COB	BI-METAL HSSCo 8% 45 mm	 Gama de Ø14/152mm	553
CBX100	BI-METAL HSS 100 mm	 Gama de Ø25/152mm	556
COBX100	BI-METAL HSSCo 8% 100 mm	 Gama de Ø25/51mm	556
CBR	HSS 5 mm	 Gama de Ø8/100mm	560
CBR..T	HSS-TiN 5 mm	 Gama de Ø8/100mm	561
CBC	HSSCo Inox 10 mm	 Gama de Ø12/100mm	562
CBCTL	HSSCo Inox TiAIN 10 mm	 Gama de Ø12/100mm	563
CCF	HSS 2 mm	 Gama de Ø10/50mm	564
CBMD	MD 35 mm	 Gama de Ø19/152mm	565
CP	12 mm	 Gama de Ø10/50mm	566

FRESAS / SERRAS CRANEANAS PARA METAL

REFERÊNCIA	Tipo e profundidade de corte	Recomendação e Aplicação Características e Gama	Pag.
CX CXL	MD 12 mm 25 mm	 Gama de Ø18/65mm	567
X	MD 5 mm	 Gama de Ø14/120mm	568
XT	MD 5 mm	 Gama de Ø16/150mm	568
CXX	MD 50 mm	 Gama de Ø14/100mm	570
C50X	MD 5 mm	 Gama de Ø14/100mm	571
MBM	MD 50 mm	 Gama de Ø35/150mm	572

FRESAS PARA MÁQUINAS COM BASE ELECTROMAGNÉTICA

REFERÊNCIA	Tipo e profundidade de corte	Recomendação e Aplicação Características e Gama	Pag.
250R 500R	HSS 30 mm 50 mm	 Gama de Ø12/50mm	576
250C 500C 750C 1000C	HSS 30 mm 50 mm 75 mm 100 mm	 Gama de Ø12/100mm	577 579
1500C 2000C	HSS 150 mm 200 mm	 Gama de Ø22/50mm - Ø26/50mm	580

GUIA PARA A SELEÇÃO DE FRESAS / SERRAS CRANEANAS

FRESAS PARA MÁQUINAS COM BASE ELECTROMAGNÉTICA

REFERÊNCIA	Tipo e profundidade de corte	Recomendação e Aplicação Características e Gama	Pag.
250T 500T	HSSCo 30 mm 50 mm	HSSCo 8% 2 x 90° WELDON 110 Kg/mm² INOX Al	578
350A 500A	MD 35 mm 50 mm	MD INOX Al Cu-Ni-La FUNDAÇÃO	581
750A 1000A	MD 75 mm 100 mm	MD INOX Al Cu-Ni-La FUNDAÇÃO	582
MB250AT MB500AT	HSSCo 25/50 mm	HSSCo 8% 2 x 90° WELDON TiAlN	583
MB350ST	MD 35 mm	MD INOX Al Cu-Ni-La FUNDAÇÃO	583

FRESAS PARA MARTELO E CONSTRUÇÃO

REFERÊNCIA	Tipo e profundidade de corte	Recomendação e Aplicação Características e Gama	Pag.
600W	MD 80 mm	SDS Plus MD Gama de Ø25/100mm	592
CW	MD 95 mm	SDS Plus SDS Max MD Gama de Ø25/200mm	593
HA	MD 54 mm	MD SDS Plus Gama de Ø25/112mm	594
MD	MD 60 mm	MD SDS Plus Gama de 22/120mm	595

FRESAS PARA MARTELO E CONSTRUÇÃO

REFERÊNCIA	Tipo e profundidade de corte	Recomendação e Aplicação Características e Gama	Pag.
MH	MD 100 mm	MD SDS Max Gama de Ø25/150mm	596
CLA PM	MD 70 mm	MD SDS Max Gama de Ø30/150mm	597
CDE CMAD	PORCELÂNICO 40 mm	PORCELÂNICO PVC Gama de Ø12/120mm - Ø20/50mm	598
CDD	DIAMANTE 60 mm	DIAMANTE Gama de Ø8/102mm	599
CAH	DIAMANTE	DIAMANTE Gama de Ø5/35mm	599
CHH	DIAMANTE 300-450 mm	DIAMANTE	600
CSE	PORCELÂNICO 35 mm	PORCELÂNICO PVC M14x2 Gama de Ø5/83mm	601
MG	CARBONETO 30 mm	tungstênio FUNDAÇÃO Gama de Ø16/114mm	603
CM	MADEIRA 60 mm Ø22/125	MD PVC Gama de Ø22/125mm	604
TB CL		FRESAS CORTA-CÍRCULOS Ø200/220/285/410 mm PLADUR GESSO	605
CDH	150 mm	DIAMANTE	608

SERRA CRANEANA PERFURADORA BIMETÁLICA AÇO RÁPIDO HSS 4/6 DENTE VARIÁVEL

Ref. CB

**HSS
M3**
4/6

Al

Cu-Ni-La
FUNDIÇÃO

PVC
**35 mm
CAPACIDADE
DE CORTE**

 Dimensões bolha ext:
 165 x 105 mm

SERRA CRANEANA Ref. CB APRESENTADA EM CAIXA E EM BLISTER

Ø mm	Ø Polegadas	CB		CB	
		Caixa		Blister	
		Ref.	€	Ref.	€
14	9/16	CB14	12,35	CB14B	12,35
16	5/8	CB16	12,35	CB16B	12,35
17	11/16	CB17	12,76	CB17B	12,76
19	3/4	CB19	12,76	CB19B	12,76
20	-	CB20	12,76	CB20B	12,76
21	13/16	CB21	12,76	CB21B	12,76
22	7/8	CB22	13,19	CB22B	13,19
24	15/16	CB24	13,54	CB24B	13,54
25	1"	CB25	13,91	CB25B	13,91
27	1.1/16	CB27	14,33	CB27B	14,33
29	1.1/8	CB29	15,11	CB29B	15,11
30	1.3/16	CB30	15,48	CB30B	15,48
32	1.1/4	CB32	15,86	CB32B	15,86
33	1.5/16	CB33	16,03	CB33B	16,03
35	1.3/8	CB35	16,39	CB35B	16,39
37	1.7/16	CB37	16,39	CB37B	16,39
38	1.1/2	CB38	16,86	CB38B	16,86
40	1.9/16	CB40	17,60	CB40B	17,60
41	1.5/8	CB41	17,60	CB41B	17,60
43	1.11/16	CB43	18,63	CB43B	18,63
44	1.3/4	CB44	19,70	CB44B	19,70
45	-	CB45	19,70	CB45B	19,70
46	1.13/16	CB46	19,80	CB46B	19,80
48	1.7/8	CB48	20,32	CB48B	20,32
50	-	CB50	20,32	CB50B	20,32
51	2"	CB51	20,32	CB51B	20,32
52	2.1/16	CB52	21,24	CB52B	21,24
54	2.1/8	CB54	21,31	CB54B	21,31
55	-	CB55	21,31	CB55B	21,31
57	2.1/4	CB57	22,42	CB57B	22,42
59	2.5/16	CB59	23,35	CB59B	23,35
60	2.3/8	CB60	23,39	CB60B	23,39

Ø mm	Ø Polegadas	CB		CB	
		Caixa		Blister	
		Ref.	€	Ref.	€
64	2.1/2	CB64	23,76	CB64B	23,76
65	2.9/16	CB65	26,58	CB65B	26,58
67	2.5/8	CB67	26,58	CB67B	26,58
68	-	CB68	26,58	CB68B	26,58
70	2.3/4	CB70	27,13	CB70B	27,13
73	2.7/8	CB73	27,63	CB73B	27,63
75	-	CB75	28,35	CB75B	28,35
76	3"	CB76	28,35	CB76B	28,35
79	3.1/8	CB79	28,96	CB79B	28,96
83	3.1/4	CB83	28,96	CB83B	28,96
86	3.3/8	CB86	29,07		
89	3.1/2	CB89	29,18		
92	3.5/8	CB92	32,20		
95	3.3/4	CB95	34,66		
98	3.7/8	CB98	35,89		
100	-	CB100	37,79		
102	4"	CB102	37,79		
104	4.1/8	CB104	41,77		
108	4.1/4	CB108	46,14		
111	4.3/8	CB111	50,62		
114	4.1/2	CB114	57,78		
121	4.3/4	CB121	64,19		
127	5"	CB127	71,13		
140	5.1/2	CB140	84,81		
146	5.3/4	CB146	90,44		
152	6"	CB152	96,10		
160	-	CB160	132,26		
168	-	CB168	145,34		
177	-	CB177	148,04		
210	-	CB210	156,12		
225	-	CB225	206,60		
250	-	CB250	252,08		

As serras craneanas de 14mm até 30mm não incluem buracos de arrasto para adaptadores com passadores.
 Consultar condições de corte na página 556.

SERRA CRANEANA PERFURADORA BIMETÁLICA AÇO RÁPIDO HSSCo 8% 4/6 DENTE VARIÁVEL

Ref. COB

**HSSCo
8%**

4/6

INOX



FUNDAÇÃO

Cu-Ni-La

- Maior duração do afiado e corte
- Cortes muito rápidos e precisos
- Menor vibração e desgaste.
- M42. Maior dureça e rendimento

**45mm
CAPACIDADE
DE CORTE**



Dimensões bolha ext:
165 x 105 mm

SERRA CRANEANA Ref. COB APRESENTADA EM CAIXA E EM BLISTER

Ø mm	Ø Polegadas	COB Caixa		COB Blister	
		Ref.	€	Ref.	€
14	9/16	COB14	13,21	COB14B	13,21
16	5/8	COB16	13,21	COB16B	13,21
17	11/16	COB17	13,65	COB17B	13,65
19	3/4	COB19	13,65	COB19B	13,65
20	-	COB20	13,65	COB20B	13,65
21	13/16	COB21	13,65	COB21B	13,65
22	7/8	COB22	13,99	COB22B	13,99
24	15/16	COB24	14,03	COB24B	14,03
25	1"	COB25	14,68	COB25B	14,68
27	1.1/16	COB27	15,31	COB27B	15,31
29	1.1/8	COB29	15,55	COB29B	15,55
30	1.3/16	COB30	15,77	COB30B	15,77
32	1.1/4	COB32	16,17	COB32B	16,17
33	1.5/16	COB33	16,36	COB33B	16,36
35	1.3/8	COB35	16,70	COB35B	16,70
37	1.7/16	COB37	16,70	COB37B	16,70
38	1.1/2	COB38	17,19	COB38B	17,19
40	1.9/16	COB40	17,93	COB40B	17,93
41	1.5/8	COB41	17,93	COB41B	17,93
43	1.11/16	COB43	19,00	COB43B	19,00
44	1.3/4	COB44	20,36	COB44B	20,36
45	-	COB45	20,36	COB45B	20,36
46	1.13/16	COB46	20,44	COB46B	20,44
48	1.7/8	COB48	20,71	COB48B	20,71
50	-	COB50	20,71	COB50B	20,71
51	2"	COB51	20,71	COB51B	20,71
52	2.1/16	COB52	22,72	COB52B	22,72
54	2.1/8	COB54	22,79	COB54B	22,79
55	-	COB55	22,79	COB55B	22,79
57	2.1/4	COB57	23,89	COB57B	23,89
59	2.5/16	COB59	24,08	COB59B	24,08
60	2.3/8	COB60	24,08	COB60B	24,08

Ø mm	Ø Polegadas	COB Caixa		COB Blister	
		Ref.	€	Ref.	€
64	2.1/2	COB64	25,43	COB64B	25,43
65	2.9/16	COB65	27,10	COB65B	27,10
67	2.5/8	COB67	27,10	COB67B	27,10
68	-	COB68	27,10	COB68B	27,10
70	2.3/4	COB70	27,66	COB70B	27,66
73	2.7/8	COB73	28,17	COB73B	28,17
75	-	COB75	28,90	COB75B	28,90
76	3"	COB76	28,90	COB76B	28,90
79	3.1/8	COB79	29,53	COB79B	29,53
83	3.1/4	COB83	29,53	COB83B	29,53
86	3.3/8	COB86	29,62		
89	3.1/2	COB89	29,75		
92	3.5/8	COB92	32,81		
95	3.3/4	COB95	37,09		
98	3.7/8	COB98	38,41		
100	-	COB100	40,44		
102	4"	COB102	40,44		
104	4.1/8	COB104	44,68		
108	4.1/4	COB108	49,38		
111	4.3/8	COB111	54,18		
114	4.1/2	COB114	63,55		
121	4.3/4	COB121	70,62		
127	5"	COB127	78,25		
140	5.1/2	COB140	93,29		
146	5.3/4	COB146	99,51		
152	6"	COB152	100,43		

R.P.M. RECOMENDADAS

FAIXA Ø mm	R.P.M
14-25	600
27-45	350
46-60	250
64-83	150
86-102	120
104-121	90
127-152	60

As serras craneanas de 14mm até 30mm não incluem buracos de arrasto para adaptadores com passadores.
Consultar condições de corte na página 556.

ADAPTADORES E ACESSÓRIOS PARA SERRAS CRANEANAS BIMETÁLICAS
ADAPTADORES COM E SEM MOLA EXPULSORA APRESENTADOS EM CAIXA E BLISTER

Ref. B5514

Ref. B5518

 → Ref. B5519
 O mais habitual

Ref. B5520



Ref. B5545

 → Ref. B5546
 O mais habitual

Ref. B5547*



Ref. B5556SDS



Ref. B5547M

SEM MOLA EXPULSORA
COM MOLA EXPULSORA

Tipo de cabo	Capacidade Ø mm	Caixa		Blister		Caixa		Blister	
		Ref.	€	Ref.	€	Ref.	€	Ref.	€
Ø 6,35 mm	14 - 30	B5514	12,99	B5514S	13,85	B5514M	14,35	5514-BME	14,38
Ø 11,0 mm	14 - 30	B5518	17,09	B5518S	18,22	B5518M	18,44	5518-BME	18,44
Ø 9,5 mm	14 - 30	B5519	17,49	B5519S	19,02	B5519M	18,81	5519-BME	20,46
Ø 11,0 mm	32 - 38	B5520	20,50	B5520S	20,50	B5520M	21,84		
Ø 11,0 mm	32 - 250	B5545	27,73	B5545S	27,73	B5545M	29,06		
Ø 9,5 mm	32 - 250	B5546	27,73	B5546S	29,58	B5546M	29,06	5546-BME	31,00
Ø 11,0 mm	32 - 250	B5547*	28,95	B5547S	31,65	B5547M	30,32	5547-BME	33,16
Ø 16,0 mm	32 - 250	B5573	30,21			B5573M	31,56		
SDS-PLUS	14 - 30	B5529SDS	23,23			B5529SDSM	23,95		
SDS-PLUS	32 - 250	B5556SDS	43,01			B5556SDSM	43,95		

MOLA EXPULSORA

B8530
0,99 €

* Adaptador rígido de alto rendimento.

BROCAS GUIA
HSS

Ref. B8534 (a mais habitual)



Ref. B8535



Ref. B8536



Ref. B8537



Ref. B8538



Ø mm	Lt mm	RASGOS DE CHAVETA	UNIDADE EMBALAGEM	ADAPTADORES CORRESPONDENTES	Caixa		Blister	
					Ref.	€	Ref.	€
6,35	83	2	10	5514-5518-5519-5520-5545-5546 5573-5529SDS -5556SDS -5547	B8534	6,49	B8534S	8,56
6,35	107	3	10	5514-5518-5519-5520-5545-5546 5573-5529SDS -5556SDS -5547	B8535	6,49	B8535S	8,56
6,35	87	1	10	5514-5518-5520-5573-5545	B8536	6,49	B8536S	8,56
6,35	82	1	10	Serras craneanas Mastergrit	B8537	5,63	B8537S	7,02
6,35	97	1	10	Serras craneanas Mastergrit	B8538	5,63	B8538S	7,02

ACCESORIOS PARA SERRAS CRANEANAS BIMETÁLICAS

EXTENSOR DE ADAPTADORES DE 300 mm



Válido para adaptadores:
Ref. 5519-5546
Cabo sextavado 9,5mm

B5500
25,35 €

ACOPLADOR DE ADAPTADORES



Este acoplador com rosca permite aos adaptadores 5514, 5518 e 5519 utilizar serras craneanas superiores a 30mm baixo condições de corte favoráveis.

B5511
8,81 €

PARAFUSOS DE REPOR (SUJECÇÃO DA BROCA AO ADAPTADOR)



Parafusos para adaptador:
Ref. 5514 - 5518 - 5519 - 5520

BSS1
2,31 €



Parafusos para adaptador:
Ref. 5545 - 5546 - 5573

BSS2
2,31 €

CONJUNTO DE CRANEANA E ANILHA ESCAREADORA PARA CARTÃO-GESSO (PLADUR)

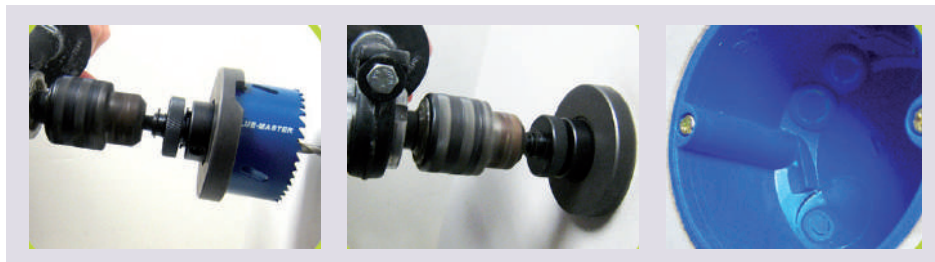

Conjunto 1 Ø67

Ref. CPL67

Conteúdo:

- 1 Serra craneana bimetalica CB67 : Ø 67 mm
- 1 Adaptador Ref. B5547
- 1 Anilha escareadora pladur Ref. CPL

92,15 €



Conjunto 2 Ø68

Ref. CPL68

Conteúdo:

- 1 Serra craneana bimetalica CB68 : Ø 68 mm
- 1 Adaptador Ref. B5547
- 1 Anilha escareadora pladur Ref. CPL

92,15 €

COMPONENTES

	DESCRIÇÃO	€
CPL	Anilha escareadora pladur	60,41
B5547	Adaptador rígido para serras craneanas Ø 32-250	28,95
CB67	Serra craneana bimetalica CB67 Ø 67 mm	26,58
CB68	Serra craneana bimetalica CB68 Ø 68 mm	26,58

SERRA CRANEANA PERFURADORA BIMETÁLICA EXTRA-LONGA AÇO RÁPIDO HSS PARA SERRALHEIROS

Ref. CBX100

HSS
M3
4/6

Al

Cu - Ni - La
FUNDIÇÃO

PVC
100 mm
CAPACIDADE
DE CORTE

CBX100

	Ø mm	€
CB25X100	25	61,59
CB27X100	27	67,82
CB29X100	29	71,54
CB30X100	30	73,32
CB32X100	32	75,12
CB33X100	33	75,97
CB35X100	35	72,53
CB38X100	38	79,87
CB40X100	40	77,87

CBX100

	Ø mm	€
CB41X100	41	83,32
CB43X100	43	88,24
CB44X100	44	88,81
CB45X100	45	88,81
CB46X100	46	89,34
CB48X100	48	89,34
CB50X100	50	90,19
CB51X100	51	90,19
CB52X100	52	98,01
CB54X100	54	98,43
CB55X100	55	98,43
CB57X100	57	103,58
CB59X100	59	107,77
CB60X100	60	108,05
CB64X100	64	109,70
CB65X100	65	122,76
CB67X100	67	122,76
CB68X100	68	122,76
CB70X100	70	125,31

CBX100

	Ø mm	€
CB73X100	73	127,63
CB75X100	75	130,90
CB79X100	79	133,80
CB83X100	83	133,80
CB86X100	86	134,24
CB89X100	89	134,77
CB92X100	92	148,63
CB95X100	95	157,03
CB98X100	98	162,63
CB100X100	100	171,25
CB102X100	102	171,25
CB104X100	104	189,29
CB108X100	108	209,08
CB111X100	111	229,44
CB114X100	114	261,82
CB127X100	127	322,31
CB140X100	140	384,30
CB146X100	146	409,87
CB152X100	152	435,48

As serras craneanas de 14mm até 30mm não incluem buracos de arrasto para adaptadores com passadores.

SERRA CRANEANA PERFURADORA BIMETÁLICA AÇO RÁPIDO HSSCo 4/6 DENTE VARIÁVEL

Ref. COBX100

HSSCo
8%
4/6

FUNDIÇÃO

Cu - Ni - La

- Maior duração do afiado e corte.
- Cortes muito rápidos e precisos.
- Menor vibração e desgaste.
- M42. Maior dureza e rendimento.

100 mm
CAPACIDADE
DE CORTE
COBX100

	Ø mm	€
COB25X100	25	81,35
COB35X100	35	95,80
COB40X100	40	102,84
COB45X100	45	115,10
COB50X100	50	115,79
COB51X100	51	115,79

ADAPTADORES PARA SERRAS CRANEANAS SERIE LONGA

BROCA GUIA

DESCRIPÇÃO	FAIXA mm	€	Ø mm	Lt mm	ADAPTADORES CORRESPONDENTES	€
B5516	14 - 30	29,48	6,35	155	B5516 / B5548	17,75
B5548	32-250	44,75				

EXPOSITORES DE SERRAS CRANEANAS BIMETÁLICAS



Ref. CB

HSS M3	4/6		Al		FUNDIÇÃO	PVC	
--------	-----	--	----	--	----------	-----	--

ADAPTADORES

EXPOSITOR DE SERRAS CRANEANAS BLUEMASTER

B5519	CB16	CB19	CB20	CB22	CB25	CB27	CB30
Ø 14-30	Ø 16	Ø 19	Ø 20	Ø 22	Ø 25	Ø 27	Ø 30
5	3	3	3	3	3	3	3
B5546	CB32	CB35	CB40	CB48	CB50	CB60	CB68
Ø32-250	Ø 32	Ø 35	Ø 40	Ø 48	Ø 50	Ø 60	Ø 68
4	3	3	2	2	2	2	2

Ref. CBEXP1 530 mm
 795,88 € ↑ → 885 mm



Ref. COB

HSSCo 8%	4/6		INOX		FUNDIÇÃO
----------	-----	--	------	--	----------

ADAPTADORES

EXPOSITOR DE SERRAS CRANEANAS HSSCo 8% BLUEMASTER

B5519	COB16	COB19	COB20	COB22	COB25	COB27	COB30
Ø 14-30	Ø 16	Ø 19	Ø 20	Ø 22	Ø 25	Ø 27	Ø 30
5	3	3	3	3	3	3	3
B5546	COB32	COB35	COB40	COB48	COB51	COB60	COB68
Ø32-250	Ø 32	Ø 35	Ø 40	Ø 48	Ø 51	Ø 60	Ø 68
4	3	3	2	2	2	2	2

Ref. COBEXP1 530 mm
 818,82 € ↑ → 885 mm



MALAS DE SERRAS CRANEANAS PERFURADORAS BIMETÁLICAS HSS
**HSS
M3**
4/6

Al

Cu-Ni-La
FUNDIÇÃO

PVC
**35 mm
CAPACIDADE
DE CORTE**

Ref. CB



Ref. CB9576

MALA DE SERRAS CRANEANAS PARA ELETRICISTAS
**10
Peças**

CB9576 7 Serras craneanas CB: Ø 16-20-25-32-40-50-68 mm

CB9570 7 Serras craneanas CB: Ø 20-25-32-40-44-60-68 mm

Conteúdo

1 Adaptador Ref. 5519 ⬡ 9,5 Capacidade 14-30

1 Adaptador Ref. 5546 ⬡ 9,5 Capacidade 32-250

1 Acoplador de adaptadores Ref. 5511

CB9576 133,24 €

CB9570 135,90 €

MALA DE SERRAS CRANEANAS PARA SERRALHEIROS
**9
Peças**

CB9571 6 Serras craneanas CB: Ø 22-35-51-60-68-73 mm

CB9574 6 Serras craneanas CB: Ø 22-35-50-60-68-73 mm

Conteúdo

1 Adaptador Ref. 5519 ⬡ 9,5 Capacidade 14-30

1 Adaptador Ref. 5546 ⬡ 9,5 Capacidade 32-250

1 Acoplador de adaptadores Ref. 5511

141,47 €

MALA DE SERRAS CRANEANAS PARA CANALIZADORES
**10
Peças**

CB9573 7 Serras craneanas CB: Ø 20-25-30-40-44-60-68 mm

CB9575 7 Serras craneanas CB: Ø 19-25-32-40-44-60-68 mm

Conteúdo

1 Adaptador Ref. 5519 ⬡ 9,5 Capacidade 14-30

1 Adaptador Ref. 5546 ⬡ 9,5 Capacidade 32-250

1 Acoplador de adaptadores Ref. 5511

135,90 €

MALA PARA MANUTENÇÃO INDUSTRIAL
**13
Peças**

CB9572 10 Serras craneanas CB: 20-22-25-32-35-40-44-60-68-76 mm

Conteúdo

1 Adaptador Ref. 5519 ⬡ 9,5 Capacidade 14-30

1 Adaptador Ref. 5546 ⬡ 9,5 Capacidade 32-250

1 Acoplador de adaptadores Ref. 5511

171,28 €



MALAS DE SERRAS CRANEANAS PERFURADORAS BIMETÁLICAS HSS

HSSCo
8%

4/6

INOX



FUNDIÇÃO



Cu-Ni-La

- Maior duração do afiado e corte
- Cortes muito rápidos e precisos
- Menor vibração e desgaste.
- M42. Maior dureza e rendimento

45 mm
CAPACIDADE
DE CORTE



Ref. COB



Ref. COB9576



MALA DE SERRAS CRANEANAS PARA ELETRICISTAS

10
Peças

COB9576 7 Serras craneanas COB: Ø 16-20-25-32-40-50-68 mm

COB9570 7 Serras craneanas COB: Ø 20-25-32-40-44-60-68 mm

Conteúdo

1 Adaptador Ref. 5519 ◻ 9,5 Capacidade 14-30

1 Adaptador Ref. 5546 ◻ 9,5 Capacidade 32-250

1 Acoplador de adaptadores Ref. 5511

COB9576 143,53 €

COB9570 149,48 €



MALA DE SERRAS CRANEANAS PARA CANALIZADORES

10
Peças

COB9573 7 Serras craneanas COB: Ø 20-25-30-40-44-60-68 mm

COB9575 7 Serras craneanas COB: Ø 19-25-32-40-44-60-68 mm

Conteúdo

1 Adaptador Ref. 5519 ◻ 9,5 Capacidade 14-30

1 Adaptador Ref. 5546 ◻ 9,5 Capacidade 32-250

1 Acoplador de adaptadores Ref. 5511

149,48 €

MALA DE SERRAS CRANEANAS PARA SERRALHEIROS

9
Peças

COB9571 6 Serras craneanas COB: Ø 22-35-51-60-68-73 mm

COB9574 6 Serras craneanas COB: Ø 22-35-50-60-68-73 mm

Conteúdo

1 Adaptador Ref. 5519 ◻ 9,5 Capacidade 14-30

1 Adaptador Ref. 5546 ◻ 9,5 Capacidade 32-250

1 Acoplador de adaptadores Ref. 5511

155,62 €

MALA PARA MANUTENÇÃO INDUSTRIAL

13
Peças

COB9572 10 Serras craneanas COB: 20-22-25-32-35-40-44-60-68-76 mm

Conteúdo

1 Adaptador Ref. 5519 ◻ 9,5 Capacidade 14-30

1 Adaptador Ref. 5546 ◻ 9,5 Capacidade 32-250

1 Acoplador de adaptadores Ref. 5511

188,40 €



FRESA PERFURADORA REAFILÁVEL HSS PARA METAIS
HSS

Ref. CBR

Al

Cu - Ni - La
FUNDIÇÃO
5 mm
CAPACIDADE
DE CORTE

Aperte as garras da bucha sobre as três faces planas de arrasto do eixo para evitar derrapagens quando faça a perfuração.

CBR			CBR			CBR		
	Ø mm	€		Ø mm	€		Ø mm	€
CBR010	10	21,95	CBR040	40	55,53	CBR070	70	140,23
CBR011	11	21,95	CBR041	41	58,21	CBR071	71	147,42
CBR012	12	22,29	CBR042	42	58,46	CBR072	72	147,42
CBR013	13	22,33	CBR043	43	61,35	CBR073	73	147,42
CBR014	14	22,33	CBR044	44	62,51	CBR074	74	147,42
CBR015	15	22,33	CBR045	45	62,84	CBR075	75	147,42
CBR016	16	22,33	CBR046	46	65,49	CBR076	76	167,63
CBR017	17	23,91	CBR047	47	65,71	CBR077	77	167,63
CBR018	18	25,73	CBR048	48	65,95	CBR078	78	167,63
CBR019	19	27,15	CBR049	49	68,04	CBR079	79	167,63
CBR020	20	28,61	CBR050	50	69,15	CBR080	80	167,63
CBR021	21	28,71	CBR051	51	84,74	CBR081	81	191,08
CBR022	22	30,09	CBR052	52	84,74	CBR082	82	191,08
CBR023	23	31,67	CBR053	53	84,74	CBR083	83	191,08
CBR024	24	33,33	CBR054	54	85,58	CBR084	84	191,08
CBR025	25	34,76	CBR055	55	85,58	CBR085	85	191,08
CBR026	26	36,21	CBR056	56	100,93	CBR086	86	200,45
CBR027	27	37,70	CBR057	57	100,93	CBR087	87	200,80
CBR028	28	39,74	CBR058	58	100,93	CBR088	88	200,80
CBR029	29	41,25	CBR059	59	100,93	CBR089	89	200,80
CBR030	30	41,30	CBR060	60	100,93	CBR090	90	200,80
CBR031	31	43,81	CBR061	61	117,88	CBR091	91	220,58
CBR032	32	44,29	CBR062	62	117,88	CBR092	92	223,00
CBR033	33	45,76	CBR063	63	117,88	CBR093	93	223,00
CBR034	34	47,07	CBR064	64	117,88	CBR094	94	223,00
CBR035	35	47,14	CBR065	65	117,88	CBR095	95	223,00
CBR036	36	50,02	CBR066	66	140,23	CBR096	96	232,69
CBR037	37	52,25	CBR067	67	140,23	CBR097	97	232,69
CBR038	38	52,43	CBR068	68	140,23	CBR098	98	232,69
CBR039	39	54,04	CBR069	69	140,23	CBR099	99	232,69
						CBR100	100	233,06

Estas fresas perfuradoras fornecem-se sempre, sem excepção, com adaptador de cabo cilíndrico e broca guia.



Ref. AT12



Ref. CM12

ADAPTADORES PARA FRESAS PERFURADORAS REAFILÁVEIS COM E SEM TiN

DESCRIPÇÃO	FAIXA Ø mm	€
AT09	Cabo Ø7mm Triangular rosca M9x1,25+broca Ø5mm	10 - 13 17,74
AT10	Cabo Ø8mm Triangular rosca M10x1,25+broca Ø5mm	14 - 22 17,74
AT12	Cabo Ø9mm Triangular rosca M12x1,25+broca Ø6mm	23 - 40 19,87
AT16	Cabo Ø10mm Triangular rosca M16x1,25+broca Ø6mm	41 - 60 25,24
AT20	Cabo Ø12mm Triangular rosca M20x1,25+broca Ø8mm	61 - 90 28,90
AT28	Cabo Ø13mm Triangular rosca M28x2,00+Broca Ø 8 mm	91 - 100 39,00
CM09	Cone Morse 2 - rosca M09x1,25 + broca Ø5mm	10 - 13 45,64
CM10	Cone Morse 2 - rosca M10x1,25 + broca Ø5mm	14 - 22 45,64
CM12	Cone Morse 2 - rosca M12x1,25 + broca Ø6mm	23 - 40 46,65
CM16	Cone Morse 2 - rosca M16x1,25 + broca Ø6mm	41 - 60 46,65
CM20	Cone Morse 3 - rosca M20x1,25 + broca Ø8mm	61 - 90 67,68
CM28	Cone Morse 4 - rosca M28x2,00 + broca Ø8mm	91 - 100 112,25

BROCAS GUIA

	DESCRIPÇÃO	FAIXA Ø mm	€
B5	HSS Ø 5 mm	10 - 22	6,96
B6	HSS Ø 6 mm	23 - 60	8,01
B8	HSS Ø 8 mm	61 - 100	8,87
B6TiN	HSS + TiN Ø 6 mm	23 - 60	12,33
B8TiN	HSS + TiN Ø 8 mm	61 - 100	14,44



FRESA PERFURADORA REAFILÁVEL HSS + TIN PARA METAIS

HSS

TiN

Ref. CBR..T



Al



Cu - Ni - La

FUNDIÇÃO

5 mm
CAPACIDADE
DE CORTE

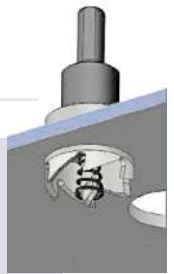

	Ø mm	€
CBR010T	10	34,61
CBR011T	11	34,97
CBR012T	12	34,97
CBR013T	13	36,79
CBR014T	14	36,79
CBR015T	15	36,79
CBR016T	16	39,01
CBR017T	17	42,68
CBR018T	18	44,17
CBR019T	19	48,60
CBR020T	20	50,79
CBR021T	21	53,00
CBR022T	22	55,19
CBR023T	23	57,77
CBR024T	24	60,74
CBR025T	25	62,58
CBR026T	26	70,29
CBR027T	27	71,77
CBR028T	28	73,60
CBR029T	29	75,08
CBR030T	30	76,54
CBR031T	31	78,76
CBR032T	32	80,24
CBR033T	33	82,44
CBR034T	34	85,04
CBR035T	35	87,95
CBR036T	36	90,17
CBR037T	37	92,74
CBR038T	38	94,92

	Ø mm	€
CBR039T	39	97,88
CBR040T	40	100,49
CBR041T	41	102,68
CBR042T	42	105,25
CBR043T	43	107,45
CBR044T	44	110,41
CBR045T	45	112,98
CBR046T	46	115,22
CBR047T	47	117,78
CBR048T	48	122,57
CBR049T	49	122,94
CBR050T	50	125,11
CBR051T	51	150,65
CBR052T	52	153,70
CBR053T	53	156,51
CBR054T	54	159,43
CBR055T	55	162,67
CBR056T	56	165,40
CBR057T	57	168,31
CBR058T	58	171,75
CBR059T	59	174,32
CBR060T	60	177,40
CBR061T	61	208,98
CBR062T	62	212,57
CBR063T	63	215,90
CBR064T	64	219,20
CBR065T	65	223,03
CBR066T	66	226,13
CBR067T	67	229,43
CBR068T	68	233,01
CBR069T	69	236,34

	Ø mm	€
CBR070T	70	242,89
CBR071T	71	243,67
CBR072T	72	247,29
CBR073T	73	250,85
CBR074T	74	254,28
CBR075T	75	257,73
CBR076T	76	261,46
CBR077T	77	264,92
CBR078T	78	268,35
CBR079T	79	272,08
CBR080T	80	279,01
CBR081T	81	279,01
CBR082T	82	282,57
CBR083T	83	286,16
CBR084T	84	289,63
CBR085T	85	293,22
CBR086T	86	296,80
CBR087T	87	300,27
CBR088T	88	303,72
CBR089T	89	307,29
CBR090T	90	312,09
CBR091T	91	322,17
CBR092T	92	325,84
CBR093T	93	329,52
CBR094T	94	333,05
CBR095T	95	336,74
CBR096T	96	340,44
CBR097T	97	343,93
CBR098T	98	347,49
CBR099T	99	351,31
CBR100T	100	356,98

Estas fresas perfuradoras fornecem-se sempre, sem excepção, com adaptador de cabo cilíndrico e broca guia.

EXPOSITOR FRESAS PERFURADORAS REAFILÁVEIS

E41P

Conteúdo:
41 fresas perfuradoras Ref. CBR
Ø 10 - Ø 50 mm

1.745,72 €



FRESA PERFURADORA REAFILÁVEL HSSCo PARA METAIS (ESPECIAL INOX)
HSSCo
INOX

Ref. CBC

Al

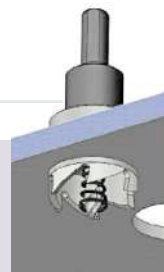
Cu-Ni-La
FUNDIÇÃO
10 mm
CAPACIDADE
DE CORTE

 Afiação especial com rompe
 as limanhas.

CBC			CBC			CBC		
	Ø mm	€		Ø mm	€		Ø mm	€
CBC012	12	36,75	CBC042	42	90,05	CBC072	72	253,47
CBC013	13	36,75	CBC043	43	92,05	CBC073	73	256,88
CBC014	14	36,75	CBC044	44	93,67	CBC074	74	260,31
CBC015	15	37,77	CBC045	45	96,29	CBC075	75	263,92
CBC016	16	38,58	CBC046	46	97,89	CBC076	76	267,95
CBC017	17	39,19	CBC047	47	100,31	CBC077	77	270,77
CBC018	18	40,22	CBC048	48	102,13	CBC078	78	274,19
CBC019	19	42,08	CBC049	49	104,11	CBC079	79	277,80
CBC020	20	43,93	CBC050	50	105,93	CBC080	80	281,81
CBC021	21	46,16	CBC051	51	149,12	CBC081	81	284,64
CBC022	22	48,82	CBC052	52	152,64	CBC082	82	288,25
CBC023	23	50,49	CBC053	53	154,77	CBC083	83	291,67
CBC024	24	52,13	CBC054	54	157,69	CBC084	84	295,07
CBC025	25	54,19	CBC055	55	161,59	CBC085	85	298,71
CBC026	26	56,24	CBC056	56	164,32	CBC086	86	302,12
CBC027	27	58,70	CBC057	57	167,05	CBC087	87	305,52
CBC028	28	60,54	CBC058	58	169,76	CBC088	88	309,15
CBC029	29	62,59	CBC059	59	172,90	CBC089	89	312,36
CBC030	30	64,64	CBC060	60	175,42	CBC090	90	315,98
CBC031	31	66,28	CBC061	61	210,27	CBC091	91	319,61
CBC032	32	68,56	CBC062	62	213,78	CBC092	92	322,82
CBC033	33	70,60	CBC063	63	216,31	CBC093	93	326,43
CBC034	34	72,84	CBC064	64	220,40	CBC094	94	330,06
CBC035	35	75,31	CBC065	65	223,71	CBC095	95	333,27
CBC036	36	76,95	CBC066	66	235,59	CBC096	96	336,70
CBC037	37	79,22	CBC067	67	238,39	CBC097	97	340,30
CBC038	38	81,89	CBC068	68	241,83	CBC098	98	343,52
CBC039	39	86,99	CBC069	69	244,22	CBC099	99	347,15
CBC040	40	88,24	CBC070	70	247,86	CBC100	100	357,60
CBC041	41	88,04	CBC071	71	249,84			

Estas fresas perfuradoras fornecem-se sempre, sem excepção, com adaptador de cabo cilíndrico e broca guia.



Ref. HCBC1

ADAPTADORES PARA FRESAS PERFURADORAS REAFILÁVEIS COM E SEM TiAlN

	DESCRIÇÃO	FAIXA Ø mm	€
HCBC0	Cabo 7mm Triangular Rosca M09x1,25+Broca Ø 5 mm	10 - 13	17,74
HCBC1	Cabo 8mm Triangular Rosca M10x1,25+Broca Ø 5 mm	14 - 22	17,74
HCBC2	Cabo 9mm Triangular Rosca M12x1,25+Broca Ø 6 mm	23 - 35	17,74
HCBC3	Cabo 10mm Triangular Rosca M16x1,25+Broca Ø 6 mm	36 - 49	19,87
HCBC4	Cabo 12mm Triangular Rosca M20x1,50+Broca Ø 8 mm	50 - 90	25,24
HCBC5	Cabo 13mm Triangular Rosca M28x2,00+Broca Ø 8 mm	91 -100	28,90
HCBC0-CM2	Cone Morse 2 Rosca M09x1,25 e Broca Ø 5 mm	10 - 13	45,64
HCBC1-CM2	Cone Morse 2 Rosca M10x1,25 e Broca Ø 5 mm	14 - 22	45,64
HCBC2-CM2	Cone Morse 2 Rosca M12x1,25 e Broca Ø 6 mm	23 - 35	46,65
HCBC2-CM3	Cone Morse 3 Rosca M12x1,25 e Broca Ø 6 mm	23 - 35	66,84
HCBC3-CM2	Cone Morse 2 Rosca M16x1,25 e Broca Ø 6 mm	36 - 49	66,84
HCBC3-CM3	Cone Morse 3 Rosca M16x1,25 e Broca Ø 6 mm	36 - 49	66,84
HCBC4-CM3	Cone Morse 3 Rosca M20x1,50 e Broca Ø 8 mm	50 - 90	67,68
HCBC4-CM4	Cone Morse 4 Rosca M20x1,50 e Broca Ø 8 mm	50 - 90	112,25
HCBC5-CM3	Cone Morse 3 Rosca M28x2,00 e Broca Ø 8 mm	91 -100	112,25
HCBC5-CM4	Cone Morse 4 Rosca M28x2,00 e Broca Ø 8 mm	91 -100	112,25

BROCAS GUIA

	DESCRIÇÃO	FAIXA Ø mm	€
PCBC1	Guia HSSCo Ø 5 mm	10 - 22	6,96
PCBC2	Guia HSSCo Ø 6 mm	23 - 49	8,01
PCBC3	Guia HSSCo Ø 8 mm	50 -100	8,87
PCBC1TL	Guia HSSCo+TiAlN Ø5 mm	10 - 22	10,09
PCBC2TL	Guia HSSCo+TiAlN Ø6 mm	23 - 49	11,63
PCBC3TL	Guia HSSCo+TiAlN Ø8 mm	50 -100	12,86

FRESA PERFURADORA REAFILÁVEL HSSCo+TiAlN PARA METAIS (ESPECIAL INOX)

HSSCo

INOX

TiAlN

Ref. CBCTL



Al



FUNDIÇÃO

**10 mm
CAPACIDADE
DE CORTE**

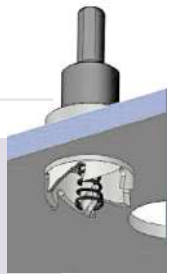

CBCTL			CBCTL			CBCTL		
	Ø mm	€		Ø mm	€		Ø mm	€
CBC012TL	12	52,69	CBC042TL	42	141,75	CBC072TL	72	367,96
CBC013TL	13	52,69	CBC043TL	43	145,17	CBC073TL	73	374,62
CBC014TL	14	52,69	CBC044TL	44	148,12	CBC074TL	74	384,81
CBC015TL	15	54,17	CBC045TL	45	152,14	CBC075TL	75	395,45
CBC016TL	16	58,64	CBC046TL	46	154,96	CBC076TL	76	395,45
CBC017TL	17	61,15	CBC047TL	47	158,68	CBC077TL	77	395,45
CBC018TL	18	62,13	CBC048TL	48	163,49	CBC078TL	78	395,45
CBC019TL	19	67,49	CBC049TL	49	164,48	CBC079TL	79	395,45
CBC020TL	20	69,82	CBC050TL	50	166,76	CBC080TL	80	409,92
CBC021TL	21	72,74	CBC051TL	51	227,29	CBC081TL	81	409,92
CBC022TL	22	77,23	CBC052TL	52	237,34	CBC082TL	82	409,92
CBC023TL	23	79,70	CBC053TL	53	245,04	CBC083TL	83	409,92
CBC024TL	24	81,82	CBC054TL	54	254,33	CBC084TL	84	409,92
CBC025TL	25	84,84	CBC055TL	55	265,93	CBC085TL	85	409,92
CBC026TL	26	94,91	CBC056TL	56	265,93	CBC086TL	86	409,92
CBC027TL	27	98,18	CBC057TL	57	265,93	CBC087TL	87	409,92
CBC028TL	28	99,93	CBC058TL	58	265,93	CBC088TL	88	409,92
CBC029TL	29	101,59	CBC059TL	59	265,93	CBC089TL	89	409,92
CBC030TL	30	103,19	CBC060TL	60	265,93	CBC090TL	90	420,97
CBC031TL	31	105,20	CBC061TL	61	319,50	CBC091TL	91	420,97
CBC032TL	32	108,05	CBC062TL	62	330,44	CBC092TL	92	420,97
CBC033TL	33	110,67	CBC063TL	63	339,56	CBC093TL	93	420,97
CBC034TL	34	114,18	CBC064TL	64	351,30	CBC094TL	94	430,11
CBC035TL	35	119,29	CBC065TL	65	362,78	CBC095TL	95	434,48
CBC036TL	36	121,33	CBC066TL	66	362,78	CBC096TL	96	434,48
CBC037TL	37	124,73	CBC067TL	67	362,78	CBC097TL	97	434,48
CBC038TL	38	128,36	CBC068TL	68	362,78	CBC098TL	98	439,20
CBC039TL	39	137,77	CBC069TL	69	362,78	CBC099TL	99	444,17
CBC040TL	40	139,62	CBC070TL	70	367,96	CBC100TL	100	469,46
CBC041TL	41	139,62	CBC071TL	71	367,96			

Estas fresas perforadoras fornecem-se sempre, sem excepção, com adaptador de cabo cilíndrico e broca guia.

EXPOSITOR FRESAS PERFURADORAS REAFILÁVEIS

CBC41P

Conteúdo: 39 fresas perforadoras Ref. CBC
Ø 12 - Ø 50 mm

2.643,87 €



* Estojos e expositores sob demanda.

FRESA HSS PERFURADORA REAFILÁVEL PARA METAIS DE ESPESSURA FINA
HSS

Ref. CCF

Al

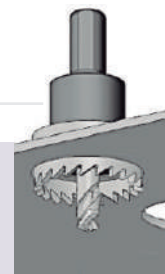
Cu - Ni - La
FUNDIÇÃO
2 mm
CAPACIDADE
DE CORTE

CCF			CCF		
	Ø mm	€		Ø mm	€
CCF12	12	32,48	CCF31	31	63,84
CCF13	13	32,54	CCF32	32	64,53
CCF14	14	32,54	CCF33	33	66,68
CCF15	15	32,54	CCF34	34	68,60
CCF16	16	32,54	CCF35	35	69,35
CCF17	17	34,82	CCF36	36	72,87
CCF18	18	37,50	CCF37	37	76,13
CCF19	19	39,55	CCF38	38	76,40
CCF20	20	41,70	CCF39	39	78,75
CCF21	21	42,03	CCF40	40	80,92
CCF22	22	43,83	CCF41	41	80,37
CCF23	23	46,15	CCF42	42	80,73
CCF24	24	48,57	CCF43	43	84,71
CCF25	25	50,66	CCF44	44	86,32
CCF26	26	52,77	CCF45	45	86,79
CCF27	27	54,93	CCF46	46	90,43
CCF28	28	57,90	CCF47	47	90,74
CCF29	29	60,10	CCF48	48	91,06
CCF30	30	60,20	CCF49	49	94,88

Estas fresas perfuradoras fornecem-se sempre, sem excepção, com adaptador de cabo cilíndrico e broca guia.



Ref. AT12



Ref. CM12

ADAPTADORES PARA FRESAS PERFURADORAS REAFILÁVEIS

	DESCRIÇÃO	FAIXA Ø mm	€
AT09	Cabo Ø7mm Triangular rosca M9x1,25+broca Ø5mm	10 - 13	17,74
AT10	Cabo Ø8mm Triangular rosca M10x1,25+broca Ø5mm	14 - 22	17,74
AT12	Cabo Ø9mm Triangular rosca M12x1,25+broca Ø6mm	23 - 40	19,87
AT16	Cabo Ø10mm Triangular rosca M16x1,25+broca Ø6mm	41 - 60	25,24
CM09	Cone Morse 2 - rosca M09x1,25 + broca Ø5mm	10 - 13	45,64
CM10	Cone Morse 2 - rosca M10x1,25 + broca Ø5mm	14 - 22	45,64
CM12	Cone Morse 2 - rosca M12x1,25 + broca Ø6mm	23 - 40	46,65
CM16	Cone Morse 2 - rosca M16x1,25 + broca Ø6mm	41 - 60	46,65

BROCAS GUIA

	DESCRIÇÃO	FAIXA Ø mm	€
B5	HSS Ø 5 mm	10 - 22	6,96
B6	HSS Ø 6 mm	23 - 60	8,01
B6TiN	HSS + TiN Ø 6 mm	23 - 60	12,33



SERRA CRANEANA PERFURADORA COM DENTES DE METAL DURO

Ref. CBMD



35 mm
CAPACIDADE DE CORTE

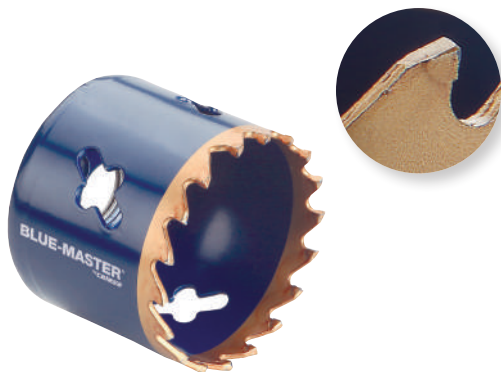

- Dentado de metal duro.
- Especial para trabalhos intensivos em aço inoxidável.
- Resistem melhor à abrasão do que às serras craneanas bimetálicas.
- Perfura onde as serras craneanas bimetálicas não conseguem.
- Aumenta e melhora a produtividade na perfuração.
- Recomenda-se não perfurar materiais metálicos maiores que 3 mm.

Ø mm			Blister	
	Ref.	€	Ref.	€
19	CBMD19	17,37	CBMD19B	17,37
22	CBMD22	20,12	CBMD22B	20,12
25	CBMD25	22,85	CBMD25B	22,85
30	CBMD30	27,42	CBMD30B	27,42
32	CBMD32	29,15	CBMD32B	29,15
35	CBMD35	32,00	CBMD35B	32,00
37	CBMD37	33,84	CBMD37B	33,84
38	CBMD38	34,75	CBMD38B	34,75
44	CBMD44	40,21	CBMD44B	40,21
48	CBMD48	43,89	CBMD48B	43,89
51	CBMD51	46,63	CBMD51B	46,63
54	CBMD54	49,37	CBMD54B	49,37
57	CBMD57	52,02	CBMD57B	52,02
60	CBMD60	54,85	CBMD60B	54,85
64	CBMD64	58,51	CBMD64B	58,51
67	CBMD67	61,26	CBMD67B	61,26
70	CBMD70	63,99	CBMD70B	63,99
76	CBMD76	69,48	CBMD76B	69,48
83	CBMD83	75,89	CBMD83B	75,89
86	CBMD86	78,64		
89	CBMD89	81,38		
95	CBMD95	86,87		
102	CBMD102	93,27		
108	CBMD108	98,74		
111	CBMD111	101,50		
114	CBMD114	104,24		
121	CBMD121	110,63		
127	CBMD127	116,11		
140	CBMD140	128,01		
146	CBMD146	133,49		
152	CBMD152	138,97		

• Os adaptadores da CBMD são os mesmos que os das serras CB e COB.



Ref. CBMD



ADAPTADORES EXPOSITOR DE SERRAS CRANEANAS HSSCo 8% BLUEMASTER

B5519	CBMD19	CBMD22	CBMD25	CBMD30	CBMD32	CBMD35	CBMD38
Ø 14-30	Ø 19	Ø 22	Ø 25	Ø 30	Ø 32	Ø 35	Ø 38
4	2	2	2	2	2	2	2
B5546	CBMD44	CBMD48	CBMD51	CBMD54	CBMD60	CBMD67	CBMD70
Ø 32-250	Ø 44	Ø 48	Ø 51	Ø 54	Ø 60	Ø 67	Ø 70
4	2	2	2	2	2	2	2

Ref. CBMDEXP1

1.286,09 €

530 mm

↑ 885 mm

FRESA METAL DURO COM PUNÇÃO RETRÁTIL PARA TRABALHOS EM SÉRIE

Ref. CP

MD



Al



Cu-Ni-La

FUNDIÇÃO

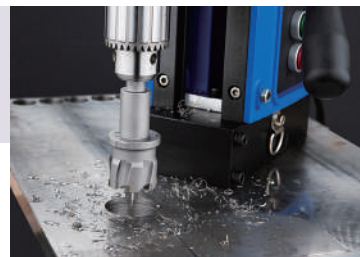
12 mm
CAPACIDADE
DE CORTE

	CP	
	Ø mm	€
CP1500	15	108,91
CP1600	16	108,91
CP1700	17	108,91
CP1800	18	108,91
CP1900	19	108,91
CP2000	20	108,91
CP2100	21	108,91
CP2200	22	120,66
CP2300	23	120,66
CP2400	24	120,66
CP2500	25	129,20
CP2600	26	129,20
CP2700	27	129,20
CP2800	28	129,20
CP2900	29	129,20
CP3000	30	129,20
CP3100	31	152,70
CP3200	32	152,70
CP3300	33	152,70
CP3400	34	152,70
CP3500	35	152,70

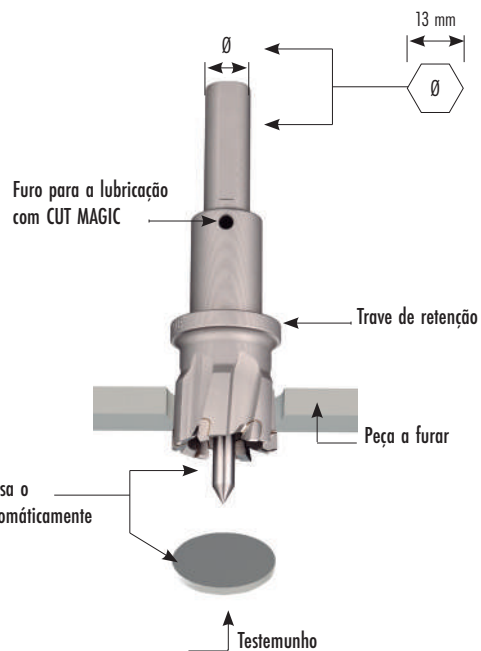
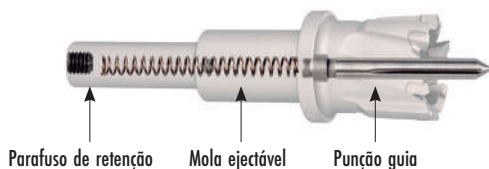
 O punção expulsa o
 testemunho automaticamente

PUNÇÃO DE REPOR

PCP01

	Ø mm	€
PCP01	Ø 6 x 53 mm	18,32

SUPER FRESAS PERFORADORAS DE METAL DURO PARA TODOS OS TIPOS DE MATERIAIS (ESPECIAL INOX)

MD



INOX

Al



Cu-Ni-La

FUNDIÇÃO

* Corpo de 1 peça

12 mm
CAPACIDADE
DE CORTE

CX18-CX40: Ø10 mm
CX41-CX100: Ø13 mm



25 mm
CAPACIDADE
DE CORTE

Ø13 mm

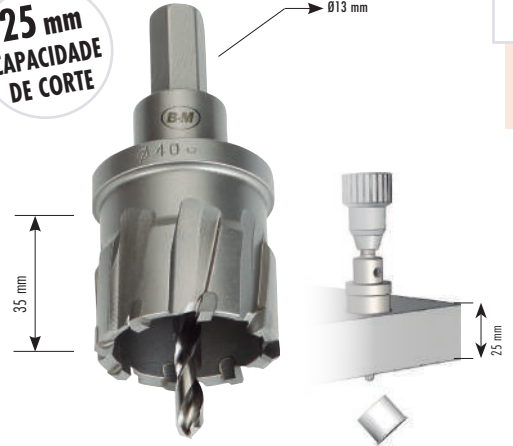

**GEOMETRIA
ESPECÍFICA
INOX**

Ref. CX

Ref. CXL

	Ø mm	Z	€
CX18	18	4	79,59
CX19	19	4	79,59
CX20	20	6	80,77
CX21	21	6	82,75
CX22	22	6	82,75
CX23	23	6	82,75
CX24	24	6	82,75
CX25	25	6	82,75
CX26	26	6	91,32
CX27	27	6	91,32
CX28	28	6	91,32
CX29	29	6	91,32
CX30	30	6	91,32
CX31	31	6	107,32
CX32	32	6	111,00
CX33	33	6	111,00
CX34	34	8	111,00
CX35	35	8	111,00
CX36	36	8	121,12
CX38	38	8	121,12
CX39	39	8	121,12
CX40	40	8	121,12
CX41	41	8	140,05
CX42	42	8	140,05
CX43	43	8	140,05
CX44	44	10	140,05
CX45	45	10	140,05
CX46	46	10	160,84

	Ø mm	Z	€
CX48	48	10	160,84
CX49	49	10	160,84
CX50	50	10	160,84
CX51	51	10	178,85
CX52	52	10	178,85
CX53	53	10	178,85
CX55	55	10	178,85
CX56	56	12	207,22
CX57	57	12	207,22
CX58	58	12	207,22
CX59	59	12	207,22
CX60	60	12	207,22
CX61	61	12	243,18
CX62	62	12	243,18
CX63	63	12	243,18
CX64	64	12	243,18
CX65	65	12	243,18
CX66	66	12	263,52
CX67	67	12	263,52
CX68	68	12	263,52
CX69	69	12	263,52
CX70	70	12	263,52
CX75	75	14	297,90
CX80	80	14	310,04
CX85	85	14	337,97
CX90	90	16	346,35
CX95	95	16	363,73
CX100	100	16	376,69

	Ø mm	Z	€
CXL18	18	6	111,70
CXL19	19	6	111,70
CXL20	20	6	111,70
CXL21	21	6	111,70
CXL22	22	6	111,70
CXL23	23	6	111,70
CXL24	24	6	111,70
CXL25	25	6	111,70
CXL26	26	6	129,45
CXL27	27	6	129,45
CXL28	28	6	129,45
CXL29	29	6	129,45
CXL30	30	6	129,45
CXL31	31	6	149,87
CXL32	32	6	149,87
CXL33	33	6	149,87
CXL34	34	6	149,87
CXL35	35	6	149,87
CXL36	36	6	163,51
CXL38	38	6	163,51
CXL39	39	6	163,51
CXL40	40	8	163,51
CXL41	41	8	189,07
CXL42	42	8	189,07
CXL43	43	8	189,07
CXL44	44	8	189,07
CXL45	45	8	189,07
CXL46	46	8	217,15

	Ø mm	Z	€
CXL48	48	8	217,15
CXL49	49	8	217,15
CXL50	50	8	217,15
CXL51	51	8	241,44
CXL52	52	8	241,44
CXL53	53	8	241,44
CXL55	55	8	241,44
CXL56	56	8	279,75
CXL57	57	8	279,75
CXL58	58	8	279,75
CXL59	59	8	279,75
CXL60	60	8	279,75
CXL61	61	10	328,30
CXL62	62	10	328,30
CXL63	63	10	328,30
CXL64	64	10	328,30
CXL65	65	10	328,30

BROCAS GUIA CX



	Ø mm	€
BRCX06X70	Ø 6 x 70 mm	16,05

BROCAS GUIA CXL



	Ø mm	€
BRCXL06X75	Ø 6 x 75 mm	18,67

SUPER FRESAS PERFURADORAS DE METAL DURO PARA TUBO E CHAPA (ESPECIAL INOX)
Ref. X
Ref. XT

MD



INOX

Al



Cu - Ni - La

FUNDIÇÃO

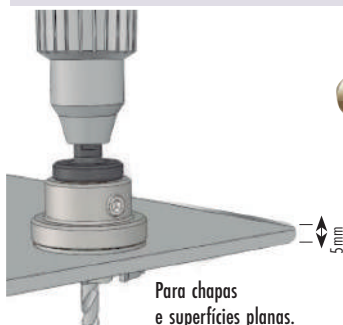
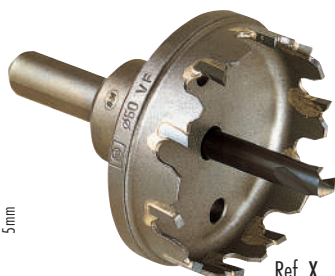
5 mm
 CAPACIDADE
 DE CORTE
Para chapas
e superfícies planas.

Ref. X

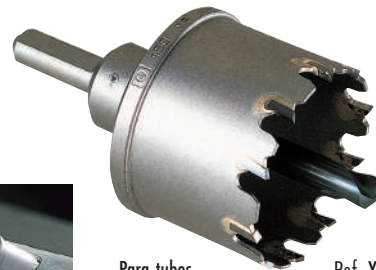
Para tubos
e superfícies curvas.

Ref. XT

X				X			
	Ø mm	Z	€		Ø mm	Z	€
X14	14,0	3	87,16	X55	55,0	12	200,93
X14,5	14,5	3	87,16	X56	56,0	12	232,81
X15	15,0	3	87,16	X57	57,0	12	232,81
X16	16,0	3	87,16	X58	58,0	12	232,81
X17	17,0	4	87,16	X59	59,0	12	232,81
X18	18,0	4	87,16	X60	60,0	12	232,81
X19	19,0	4	87,16	X61	61,0	12	273,21
X20	20,0	4	87,16	X62	62,0	12	273,21
X21	21,0	4	87,16	X63	63,0	12	273,21
X22	22,0	4	87,16	X64	64,0	12	273,21
X23	23,0	4	87,16	X65	65,0	12	273,21
X24	24,0	4	87,16	X66	66,0	12	296,04
X25	25,0	4	87,16	X67	67,0	12	296,04
X26	26,0	4	100,99	X68	68,0	12	296,04
X27	27,0	4	100,99	X69	69,0	12	296,04
X28	28,0	6	100,99	X70	70,0	12	296,04
X29	29,0	6	100,99	X71	71,0	14	319,96
X30	30,0	6	100,99	X72	72,0	14	319,96
X31	31,0	6	116,94	X73	73,0	14	319,96
X32	32,0	6	116,94	X74	74,0	14	319,96
X33	33,0	6	116,94	X75	75,0	14	319,96
X34	34,0	6	116,94	X76	76,0	14	343,91
X35	35,0	8	116,94	X77	77,0	14	343,91
X36	36,0	8	136,07	X78	78,0	14	343,91
X37	37,0	8	136,07	X79	79,0	14	343,91
X38	38,0	8	136,07	X80	80,0	14	343,91
X39	39,0	8	136,07	X81	81,0	14	380,55
X40	40,0	8	136,07	X82	82,0	16	380,55
X41	41,0	8	157,33	X83	83,0	16	380,55
X42	42,0	10	157,33	X84	84,0	16	380,55
X43	43,0	10	157,33	X85	85,0	16	380,55
X44	44,0	10	157,33	X89	89,0	16	417,77
X45	45,0	10	157,33	X90	90,0	16	417,77
X46	46,0	10	180,72	X91	91,0	16	434,78
X47	47,0	10	180,72	X92	92,0	16	434,78
X48	48,0	10	180,72	X95	95,0	16	434,78
X49	49,0	10	180,72	X100	100,0	18	463,49
X50	50,0	10	180,72	X102	102,0	18	511,31
X51	51,0	10	200,93	X105	105,0	18	511,31
X52	52,0	10	200,93	X110	110,0	20	563,40
X53	53,0	10	200,93	X115	115,0	20	619,76
X54	54,0	10	200,93	X120	120,0	20	682,99

XT				XT			
	Ø mm	Z	€		Ø mm	Z	€
XT16	16,0	3	130,85	XT62	62,0	12	446,48
XT17	17,0	4	130,85	XT65	65,0	12	446,48
XT18	18,0	4	130,85	XT70	70,0	12	467,72
XT19	19,0	4	130,85	XT75	75,0	14	506,00
XT20	20,0	4	130,85	XT80	80,0	14	544,28
XT21	21,0	4	130,85	XT85	85,0	16	601,65
XT22	22,0	4	130,85	XT90	90,0	16	659,09
XT23	23,0	4	130,85	XT95	95,0	16	690,98
XT24	24,0	4	130,85	XT100	100,0	18	733,49
XT25	25,0	4	130,85	XT105	105,0	18	807,90
XT26	26,0	4	151,65	XT110	110,0	20	892,95
XT27	27,0	4	151,65	XT115	115,0	20	982,26
XT28	28,0	6	151,65	XT120	120,0	20	1.084,31
XT29	29,0	6	151,65	XT130	130,0	20	1.699,93
XT30	30,0	6	151,65	XT140	140,0	25	1.997,28
XT31	31,0	6	175,50	XT150	150,0	28	2.423,68
XT32	32,0	6	175,50				
XT33	33,0	6	175,50				
XT34	34,0	6	175,50				
XT35	35,0	8	175,50				
XT36	36,0	8	204,14				
XT37	37,0	8	204,14				
XT38	38,0	8	204,14				
XT39	39,0	8	204,14				
XT40	40,0	8	204,14				
XT41	41,0	8	236,01				
XT42	42,0	10	236,01				
XT43	43,0	10	236,01				
XT44	44,0	10	236,01				
XT45	45,0	10	236,01				
XT46	46,0	10	267,91				
XT47	47,0	10	267,91				
XT48	48,0	10	267,91				
XT49	49,0	10	267,91				
XT50	50,0	10	267,91				
XT51	51,0	10	301,63				
XT52	52,0	10	301,63				
XT53	53,0	10	301,63				
XT54	54,0	10	301,63				
XT55	55,0	12	301,63				
XT60	60,0	12	446,48				
XT61	61,0	12	446,48				

BROCAS GUIA HSSCo PARA METAIS

	FAIXA Ø mm	€		FAIXA Ø mm	€
X6	14 - 59	14,15	XT8	23 - 59	25,84
X8	60 - 120	16,70	XT8L	60 - 100	33,33
XT6	6 - 22	19,33	XT8XL	105 - 120	37,66

TABELA DE SELEÇÃO SUPER FRESAS PERFURADORAS MULTI-TAREFA DE METAL DURO



5 mm
CAPACIDADE
DE CORTE



50 mm
CAPACIDADE
DE CORTE

Ref. C50X

Ref. CXX

	<p>9 mm</p>	<p>Ø14-60 Ref. BCX1</p>	+	<p>Ref. C50X</p>	+	<p>Ref. CXX2</p>	=	
	<p>11 mm</p>	<p>Ø14-100 Ref. BCX2</p>						
	<p>9 mm</p>	<p>Ø14-60 Ref. BCX1</p>						
	<p>11 mm</p>	<p>Ø14-100 Ref. BCX2</p>						
	<p>FEIN 18-00 mm</p> <p>Ref. CXX18W</p>		+	<p>Ref. C50X</p>	+	<p>Ref. P750CA</p>	=	
	<p>DUPLO WELDON 19-05 mm</p> <p>Ref. CXXW</p>							
	<p>Ø14-100 Ref. CXXCM2</p>		+	<p>Ref. C50X</p>	+	<p>Ref. CXX2</p>	=	
	<p>Ø14-150 Ref. CXXCM3</p>							

SUPER FRESA DE METAL DURO PERFURADORA MULTI-TAREFA PARA MACIÇOS
MD

Ref. CXX

Al

Cu - Ni - La

FUNDAÇÃO
50 mm
 CAPACIDADE
 DE CORTE

CXX			CXX		
	Ø mm	€		Ø mm	€
CXX14	14	131,77	CXX45	45	223,03
CXX15	15	131,77	CXX46	46	256,15
CXX16	16	131,77	CXX47	47	256,15
CXX17	17	131,77	CXX48	48	256,15
CXX18	18	131,77	CXX49	49	256,15
CXX19	19	131,77	CXX50	50	256,15
CXX20	20	131,77	CXX51	51	284,82
CXX21	21	131,77	CXX52	52	284,82
CXX22	22	131,77	CXX53	53	284,82
CXX23	23	131,77	CXX54	54	284,82
CXX24	24	131,77	CXX55	55	284,82
CXX25	25	131,77	CXX56	56	330,00
CXX26	26	152,70	CXX57	57	330,00
CXX27	27	152,70	CXX58	58	330,00
CXX28	28	152,70	CXX59	59	330,00
CXX29	29	152,70	CXX60	60	330,00
CXX30	30	152,70	CXX61	61	387,28
CXX31	31	176,78	CXX62	62	387,28
CXX32	32	176,78	CXX63	63	387,28
CXX33	33	176,78	CXX64	64	387,28
CXX34	34	176,78	CXX65	65	387,28
CXX35	35	176,78	CXX66	66	454,99
CXX36	36	192,88	CXX67	67	454,99
CXX37	37	192,89	CXX68	68	454,99
CXX38	38	192,88	CXX69	69	454,99
CXX39	39	192,88	CXX70	70	454,99
CXX40	40	192,88	CXX75	75	472,11
CXX41	41	223,03	CXX80	80	510,73
CXX42	42	223,03	CXX85	85	547,09
CXX43	43	223,03	CXX90	90	588,33
CXX44	44	223,03	CXX100	100	631,98

ADAPTADORES PARA FRESA PERFURADORA MULTI-TAREFA CABO SEXTAVADO

	DESCRIÇÃO	RANGO Ø mm	€
BCX1	Cabo sextavado 9 mm	14 - 60	20,92
BCX2	Cabo sextavado 11 mm	14 - 100	20,92

ADAPTADORES PARA FRESA PERFURADORA MULTI-TAREFA CABO CÓNICO

	DESCRIÇÃO	RANGO Ø mm	€
CXXCM2	Cabo Cone Morse 2	14 - 100	37,89
CXXCM3	Cabo Cone Morse 3	14 - 150	40,31

BROCA GUIA

	DESCRIÇÃO	CXX	€
CXX1	Ø 6 x 90L mm		6,79

ADAPTADORES BASE ELECTROMAGNÉTICA

Tipo Fein



Tipo Weldon

	DESCRIÇÃO	CXX	€
CXX18W	Cabo Fein 18,00 mm		37,89
CXXW	Cabo Weldon 19,05 mm		37,89

PUNÇÃO

	DESCRIÇÃO	P	€
P750CA	Ø 6.35 mm x 100 mm		29,20

SUPER FRESA DE METAL DURO PERFORADORA MULTI-TAREFA PARA TUBO E CHAPA

MD

Ref. C50X



5 mm
CAPACIDADE
DE CORTE



ADAPTADORES PARA FRESA PERFORADORA MULTI-TAREFA CABO SEXTAVADO



DESCRIÇÃO		RANGO Ø mm	€
BCX1	Cabo sextavado 9 mm	14 - 60	20,92
BCX2	Cabo sextavado 11 mm	14 - 100	20,92

ADAPTADORES PARA FRESA PERFORADORA MULTI-TAREFA CABO CÓNICO



DESCRIÇÃO		RANGO Ø mm	€
CXXCM2	Cabo Cone Morse 2	14 - 100	37,89
CXXCM3	Cabo Cone Morse 3	14 - 150	40,31

BROCA GUIA



DESCRIÇÃO		CXX	€
CXX2	Ø 6 x 75L mm		6,37

C50X			C50X		
	Ø mm	€		Ø mm	€
C50X14	14	62,76	C50X45	45	137,95
C50X15	15	62,76	C50X46	46	161,83
C50X16	16	62,76	C50X47	47	161,83
C50X17	17	62,76	C50X48	48	161,83
C50X18	18	62,76	C50X49	49	161,83
C50X19	19	70,84	C50X50	50	161,83
C50X20	20	70,84	C50X51	51	184,96
C50X21	21	70,84	C50X52	52	184,96
C50X22	22	70,84	C50X53	53	184,96
C50X23	23	70,84	C50X54	54	184,96
C50X24	24	70,84	C50X55	55	184,96
C50X25	25	70,84	C50X56	56	215,33
C50X26	26	77,06	C50X57	57	215,33
C50X27	27	77,06	C50X58	58	215,33
C50X28	28	77,06	C50X59	59	215,33
C50X29	29	77,06	C50X60	60	215,33
C50X30	30	77,06	C50X61	61	261,29
C50X31	31	95,04	C50X62	62	261,29
C50X32	32	95,04	C50X63	63	261,29
C50X33	33	95,04	C50X64	64	261,29
C50X34	34	95,04	C50X65	65	261,29
C50X35	35	95,04	C50X66	66	284,90
C50X36	36	114,36	C50X67	67	284,90
C50X37	37	114,36	C50X68	68	284,90
C50X38	38	114,36	C50X69	69	284,90
C50X39	39	114,36	C50X70	70	284,90
C50X40	40	114,36	C50X75	75	381,95
C50X41	41	137,95	C50X80	80	405,81
C50X42	42	137,95	C50X85	85	429,70
C50X43	43	137,95	C50X90	90	462,95
C50X44	44	137,95	C50X100	100	627,68

ADAPTADORES BASE ELECTROMAGNÉTICA



Tipo Fein



Tipo Weldon

DESCRIÇÃO		CXX	€
CXX18W	Cabo Fein 18,00mm		37,89
CXXW	Cabo Weldon 19,05mm		37,89

PUNÇÃO



DESCRIÇÃO		P	€
P750CA	Ø 6.35mm x 100mm		29,20

**FRESA PERFURADORA PARA TRABALHOS PESADOS COM DENTES DE METAL DURO E MUDANÇA POLY-CLICK
 ENCAIXÁVEL A CONES MORSE Nº4 E Nº5, COM REFRIGERAÇÃO INTERIOR**

Ref. MBM

MD

55
HRc

INOX

Al

FUNDIÇÃO

50 mm
 CAPACIDADE
 DE CORTE

- Usar em todos os casos a refrigeração interior.
- Não esgotar a vida dos dentes até o final, para permitir posteriores re-afiados.
- O encontro da fresa perfuradora com o material tem que ser sutil de maneira que possamos evitar rupturas dos dentes por choques.



MBM			
	Ø mm	Z	€
MBM35	35,0	4	66,88*
MBM36	36,0	4	66,88*
MBM38	38,0	4	66,88*
MBM40	40,0	6	78,82*
MBM42	42,0	6	78,82*
MBM43	43,0	6	78,82*
MBM44	44,0	6	78,82*
MBM45	45,0	6	86,92*
MBM48	48,0	6	86,92*
MBM49	49,0	6	86,92*
MBM50	50,0	6	97,44*
MBM51	51,0	6	97,44*
MBM52	52,0	6	97,44*
MBM53	53,0	6	97,44*
MBM54	54,0	6	97,44*
MBM56	56,0	6	107,94*
MBM58	58,0	6	107,94*
MBM60	60,0	6	126,09*
MBM61	61,0	6	126,09*
MBM62	62,0	6	126,09*

MBM			
	Ø mm	Z	€
MBM65	65,0	6	126,09*
MBM66	66,0	6	136,60*
MBM68	68,0	6	136,60*
MBM70	70,0	6	136,60*
MBM75	75,0	6	147,10*
MBM77	77,0	6	157,62*
MBM78	78,0	6	157,62*
MBM80	80,0	6	157,62*
MBM82	82,0	6	247,68*
MBM85	85,0	6	247,68*
MBM90	90,0	6	270,20*
MBM95	95,0	6	290,68*
MBM110	110,0	6	252,20*
MBM115	115,0	6	276,07*
MBM125	125,0	6	351,05*
MBM130	130,0	6	396,44*
MBM140	140,0	6	472,85*

*Até o fim das existências.

**ADAPTADORES CABO CÔNICO
 COM PUNÇÃO**

	DESCRIÇÃO	€
500MT4	Adaptadores cone morse 4	198,70*
500MT5	Adaptadores cone morse 5	205,38*

PERFURADOR DE CHAPAS FINAS ATÉ 4 mm

Ref. PC

**ATÉ
4 mm
CHAPAS FINAS**



Modo de utilização

- Faça o furo previo com a broca escareadora ref. AV30.
- Introduza o parafuso Ref. PCM pelo furo feito.
- Do lado contrário roscar a lâmina Ref. PCC no parafuso.
- Aplique o torque até que a lâmina Ref. PCC corte a chapa contra a copo Ref. PBC.
- Use CUT MAGIC para trabalhar com o perfurador Ref. PC.



METRICA PARAFUSO	ESPESSURA MÁXIMA DA CHAPA A PERFORAR			
	AÇO NORMAL	INOXIDÁVEL	NÃO FERROSOS	PLÁSTICOS
M10x1.0	2.00 mm	1.00 mm	4.00 mm	4.00 mm
M12x1.5	3.00 mm	1.50 mm	4.00 mm	4.00 mm
M16x1.5	3.00 mm	1.50 mm	4.00 mm	4.00 mm

	Ø	PC
		€
PC1270	12,70 PG7	34,95
PC1400	14,00	35,50
PC1520	15,20 PG9	35,85
PC1600	16,00	35,85
PC1650	16,50	36,65
PC1700	17,00	37,16
PC1800	18,00	37,16
PC1860	18,60 PG11	39,20
PC1900	19,00	39,20
PC2000	20,00	40,10
PC2040	20,40 PG13,5	40,10
PC2100	21,00	41,18
PC2200	22,00	42,83
PC2250	22,50 PG16	42,83
PC2300	23,00	44,34
PC2400	24,00	44,34
PC2500	25,00	47,08
PC2540	25,40	47,08

	Ø	PC
		€
PC2600	26,00	48,65
PC2700	27,00	48,65
PC2830	28,30 PG21	48,65
PC2900	29,00	52,22
PC3000	30,00	52,22
PC3100	31,00	52,22
PC3200	32,00	52,93
PC3250	32,50	60,08
PC3300	33,00	60,08
PC3400	34,00	60,08
PC3500	35,00	60,08
PC3600	36,00	64,85
PC3700	37,00 PG29	64,85
PC3800	38,00	64,85
PC3900	39,00	82,31
PC4000	40,00	82,31
PC4050	40,50	82,75
PC4100	41,00	82,75

	Ø	PC
		€
PC4200	42,00	89,93
PC4300	43,00	89,93
PC4400	44,00	92,63
PC4500	45,00	97,79
PC4600	46,00	97,79
PC4700	47,00 PG36	99,41
PC4800	48,00	107,28
PC4900	49,00	107,28
PC5000	50,00	110,57
PC5050	50,50	117,62
PC5100	51,00	117,62
PC5200	52,00	121,06
PC5300	53,00	121,06
PC5400	54,00 PG42	127,36
PC5500	55,00	127,36
PC6000	60,00 PG48	157,54
PC6350	63,50	181,06

PORCA E ANILHA



	DESCRÇÃO	PCM
		€
PCM10	(Rosca M10 x 1,00) perfuradores desde Ø 12,70 - 25,40 mm	4,97
PCM12	(Rosca M12 x 1,50) perfuradores desde Ø 26 - 41 mm	4,97
PCM16	(Rosca M16 x 1,50) perfuradores desde Ø 42 - 63,50 mm	5,65

COPO



PBC

Consulte o preço para cada diâmetro

LÂMINA DE CORTE



PCC

Consulte o preço para cada diâmetro

CONDIÇÕES DE CORTE PARA SERRAS CRANEANAS HSS E HSSCo

TABELA DE AVANÇOS

mm/VOLTA					
CB - COB - CBR	0,053	-	0,05	0,075	0,12
CBC - CCF	0,063	-	0,055	0,085	0,15

SELEÇÃO DE R.P.M. PARA SERRAS CRANEANAS CB - COB - CBR - CBC - CCF

Vc (m/mín.)	SELEÇÃO DE DIÂMETRO (Ø mm)													
	10	15	20	25	30	35	40	50	60	70	80	90	100	
100	3183	2122	1952	1273	1061	909	796	637	531	455	398	354	318	
95	3024	2016	1512	1512	1008	864	756	605	504	432	378	336	302	
90	2865	1910	1432	1432	955	819	716	573	477	409	358	318	286	
85	2706	1804	1353	1353	902	773	676	541	451	387	338	301	271	
80	2547	1698	1273	1276	849	728	637	509	424	364	318	283	255	
75	2387	1592	1194	1194	796	682	597	477	398	341	298	265	239	
70	2228	1485	1114	1114	743	637	557	446	371	318	279	248	223	
65	2069	1379	1035	1035	690	591	517	414	345	296	259	230	207	
60	1910	1273	955	922	637	546	477	382	318	273	239	212	191	
55	1751	1167	875	875	584	500	438	350	292	250	219	195	175	
50	1592	1061	796	796	531	455	398	318	265	227	199	177	159	
45	1432	955	716	716	477	409	658	286	239	205	179	159	143	
40	1273	849	637	637	424	364	618	255	212	192	159	141	127	
35	1114	743	557	557	371	318	279	223	186	159	139	124	111	
30	955	637	477	477	318	273	239	191	159	136	119	106	95	
25	796	531	398	398	265	227	199	159	133	114	99	88	80	
20	637	424	318	318	212	182	159	127	106	91	80	71	64	
15	477	318	239	239	159	136	119	95	80	68	60	53	48	
10	318	212	159	159	106	91	80	64	53	45	40	35	32	

CONDIÇÕES DE CORTE PARA FRESAS PERFURADORAS HSS E HSSCo

TABELA DE AVANÇOS

mm/VOLTA						
LEVES: CX - CXL - X - XT	0,035	0,025	0,02	0,040	0,075	0,020
C50X - CXX - MBM - CBMD - CP	0,10	0,075	0,095	0,15	0,22	0,07

SELEÇÃO DE R.P.M. PARA FRESAS PERFURADORAS CX - CXL - X - XT - C50X - CXX - MBM - CBMD - CP

Vc (m/mín.)	SELEÇÃO DE DIÂMETRO (Ø mm)													
	10	15	20	25	30	35	40	50	60	70	80	90	100	
100	3183	2122	1952	1273	1061	909	796	637	531	455	398	354	318	
95	3024	2016	1512	1512	1008	864	756	605	504	432	378	336	302	
90	2865	1910	1432	1432	955	819	716	573	477	409	358	318	286	
85	2706	1804	1353	1353	902	773	676	541	451	387	338	301	271	
80	2547	1698	1273	1276	849	728	637	509	424	364	318	283	255	
75	2387	1592	1194	1194	796	682	597	477	398	341	298	265	239	
70	2228	1485	1114	1114	743	637	557	446	371	318	279	248	223	
65	2069	1379	1035	1035	690	591	517	414	345	296	259	230	207	
60	1910	1273	955	922	637	546	477	382	318	273	239	212	191	
55	1751	1167	875	875	584	500	438	350	292	250	219	195	175	
50	1592	1061	796	796	531	455	398	318	265	227	199	177	159	
45	1432	955	716	716	477	409	658	286	239	205	179	159	143	
40	1273	849	637	637	424	364	618	255	212	192	159	141	127	
35	1114	743	557	557	371	318	279	223	186	159	139	124	111	
30	955	637	477	477	318	273	239	191	159	136	119	106	95	
25	796	531	398	398	265	227	199	159	133	114	99	88	80	
20	637	424	318	318	212	182	159	127	106	91	80	71	64	
15	477	318	239	239	159	136	119	95	80	68	60	53	48	
10	318	212	159	159	106	91	80	64	53	45	40	35	32	